

High Temperature Accuracy Integrated Silicon Pressure Sensor for Measuring Absolute Pressure, On-Chip Signal Conditioned, Temperature Compensated and Calibrated

MPXH6250A MPXHZ6250A Series

20 to 250 kPa (3 to 36 psi)
0.3 to 4.9 V Output

The Freescale MPXH6250A series sensor integrates on-chip, bipolar op amp circuitry and thin film resistor networks to provide a high output signal and temperature compensation. The small form factor and high reliability of on-chip integration make the Freescale MAP sensor a logical and economical choice for automotive system designers.

The MPXH6250A series piezoresistive transducer is a state-of-the-art, monolithic, signal conditioned, silicon pressure sensor. This sensor combines advanced micromachining techniques, thin film metallization, and bipolar semiconductor processing to provide an accurate, high level analog output signal that is proportional to applied pressure.

Features

- Improved Accuracy at High Temperature
- Available in Super Small Outline Package
- 1.5% Maximum Error over 0° to 85°C
- Ideally suited for Microprocessor or Microcontroller-Based Systems
- Temperature Compensated from -40° to +125°C
- Durable Thermoplastic (PPS) Surface Mount Package

Application Examples

- Industrial Controls
- Engine Control/Manifold Absolute Pressure (MAP)/Liquefied Petroleum Gas (LPG)

ORDERING INFORMATION								
Device Name	Case No.	# of Ports			Pressure Type			Device Marking
		None	Single	Dual	Gauge	Differential	Absolute	
Super Small Outline Package (MPXH6250A Series)								
MPXH6250A6U	1317	•					•	MPXH6250A
MPXH6250A6T1	1317	•					•	MPXH6250A
MPXH6250AC6U	1317A		•				•	MPXH6250A
MPXH6250AC6T1	1317A		•				•	MPXH6250A
Super Small Outline Package (Media Resistant Gel) (MPXHZ6250A Series)								
MPXHZ6250A6T1	1317	•					•	MPXHZ6250A
MPXHZ6250A6U	1317	•					•	MPXHZ6250A
MPXHZ6250AC6T1	1317A		•				•	MPXHZ6250A

SUPER SMALL OUTLINE PACKAGE

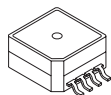

MPXH6250A6U/6T1
MPXHZ6250A6U/6T1
CASE 1317

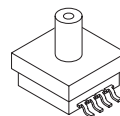

MPXH6250AC6U/C6T1
MPXHZ6250AC6T1
CASE 1317A

Operating Characteristics

Table 1. Operating Characteristics ($V_S = 5.1$ Vdc, $T_A = 25^\circ\text{C}$ unless otherwise noted, $P_1 > P_2$.)

Characteristic	Symbol	Min	Typ	Max	Unit
Pressure Range	P_{OP}	20	—	250	kPa
Supply Voltage ⁽¹⁾	V_S	4.74	5.1	5.46	Vdc
Supply Current	I_o	—	6.0	10	mAdc
Minimum Pressure Offset @ $V_S = 5.1$ Volts ⁽²⁾	V_{off}	0.133	0.204	0.274	Vdc
Full Scale Output @ $V_S = 5.1$ Volts ⁽³⁾	V_{FSO}	4.826	4.896	4.966	Vdc
Full Scale Span @ $V_S = 5.1$ Volts ⁽⁴⁾	V_{FSS}	4.552	4.692	4.833	Vdc
Accuracy ⁽⁵⁾	—	—	—	±1.5	% V_{FSS}
Sensitivity	V/P	—	20 20.4	—	mV/kPa
Response Time ⁽⁶⁾	t_R	—	1.0	—	ms
Warm-Up Time ⁽⁷⁾	—	—	20	—	ms
Offset Stability ⁽⁸⁾	—	—	±0.25	—	% V_{FSS}

1. Device is ratiometric within this specified excitation range.
2. Offset (V_{off}) is defined as the output voltage at the minimum rated pressure.
3. Full Scale Output (V_{FSO}) is defined as the output voltage at the maximum or full rated pressure.
4. Full Scale Span (V_{FSS}) is defined as the algebraic difference between the output voltage at full rated pressure and the output voltage at the minimum rated pressure.
5. Accuracy is the deviation in actual output from nominal output over the entire pressure range and temperature range as a percent of span at 25°C due to all sources of error including the following:
 - Linearity: Output deviation from a straight line relationship with pressure over the specified pressure range.
 - Temperature Hysteresis: Output deviation at any temperature within the operating temperature range, after the temperature is cycled to and from the minimum or maximum operating temperature points, with zero differential pressure applied.
 - Pressure Hysteresis: Output deviation at any pressure within the specified range, when this pressure is cycled to and from the minimum or maximum rated pressure, at 25°C .
 - TcSpan: Output deviation over the temperature range of 0 to 85°C , relative to 25°C .
 - TcOffset: Output deviation with minimum rated pressure applied, over the temperature range of 0 to 85°C , relative to 25°C .
 - Variation from Nominal: The variation from nominal values, for Offset or Full Scale Span, as a percent of V_{FSS} , at 25°C .
6. Response Time is defined as the time for the incremental change in the output to go from 10% to 90% of its final value when subjected to a specified step change in pressure.
7. Warm-up Time is defined as the time required for the product to meet the specified output voltage after the Pressure has been stabilized.
8. Offset Stability is the product's output deviation when subjected to 1000 hours of Pulsed Pressure, Temperature Cycling with Bias Test.

Maximum Ratings

Table 2. Maximum Ratings⁽¹⁾

Rating	Symbol	Value	Unit
Maximum Pressure (P1 > P2)	P_{MAX}	1000	kPa
Storage Temperature	T_{STG}	-40 to +125	°C
Operating Temperature	T_A	-40 to +125	°C
Output Source Current @ Full Scale Output ⁽²⁾	I_{O+}	0.5	mAdc
Output Sink Current @ Minimum Pressure Offset ²	I_{O-}	-0.5	mAdc

1. Exposure beyond the specified limits may cause permanent damage or degradation to the device.
2. Maximum Output Current is controlled by effective impedance from V_{out} to GND or V_{out} to V_S in the application circuit.

Figure 1 shows a block diagram of the internal circuitry integrated on a pressure sensor chip.

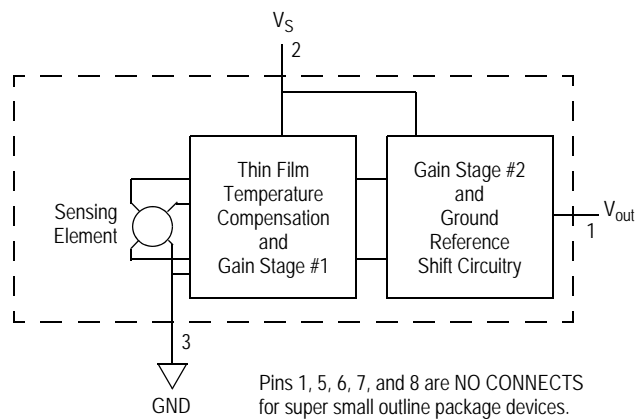

Figure 1. Integrated Pressure Sensor Schematic

On-chip Temperature Compensation and Calibration

Figure 2 illustrates the absolute sensing chip in the basic Super Small Outline chip carrier (Case 1317). Figure 3 illustrates a typical application circuit (output source current operation).

Figure 4 shows the sensor output signal relative to pressure input. Typical minimum and maximum output curves are shown for operation over 0 to 85°C temperature range. The output will saturate outside of the rated pressure range.

A fluorosilicone gel isolates the die surface and wire bonds from the environment, while allowing the pressure signal to be transmitted to the silicon diaphragm. The MPXH6250A series pressure sensor operating characteristics, internal reliability and qualification tests are based on use of dry air as the pressure media. Media other than dry air may have adverse effects on sensor performance and long-term reliability. Contact the factory for information regarding media compatibility in your application.

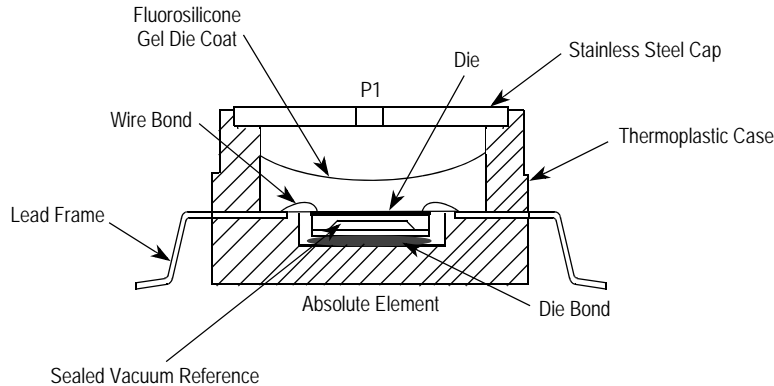

Figure 2. Cross Sectional Diagram SSOP (not to scale)

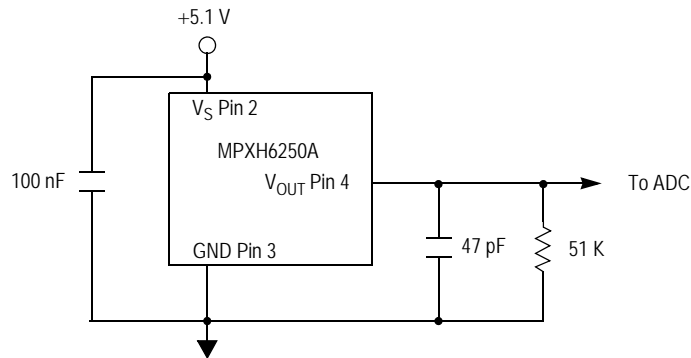

Figure 3. Typical Application Circuit (Output Source Current Operation)

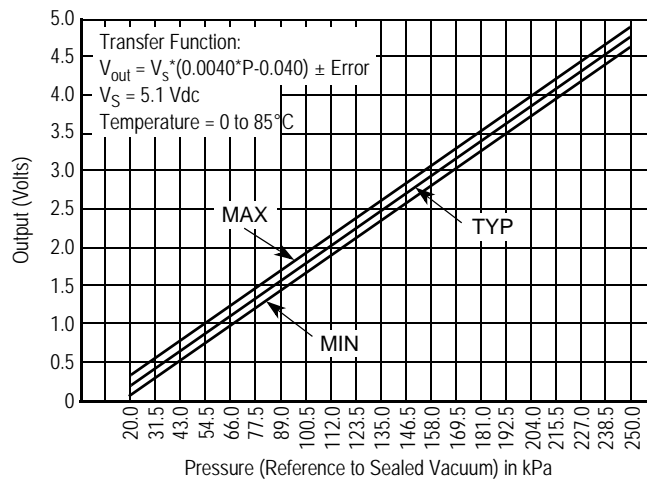
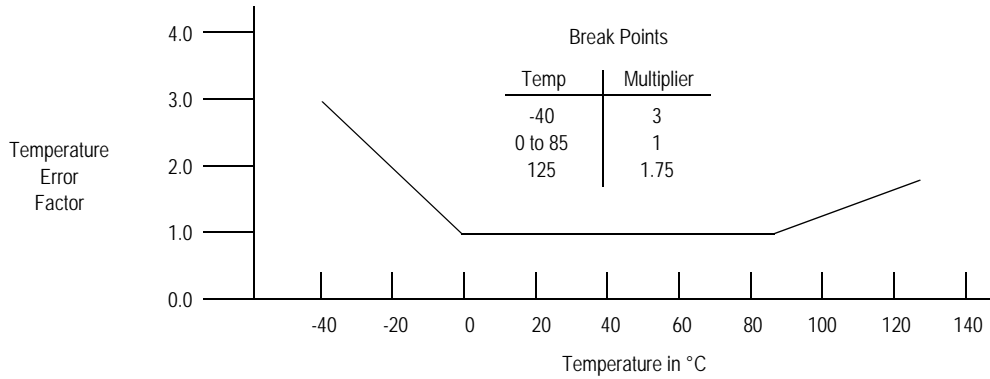

Figure 4. Output vs. Absolute Pressure

Transfer Function

Nominal Transfer Value: $V_{out} = V_S \times (0.004 \times P - 0.040)$
 $\pm (\text{Pressure Error} \times \text{Temp Factor} \times 0.004 \times V_S)$
 $V_S = 5.1 \pm 0.36 \text{ Vdc}$

Temperature Error Band



NOTE: The Temperature Multiplier is a linear response from 0°C to -40°C and from 85°C to 125°C.

Pressure Error Band

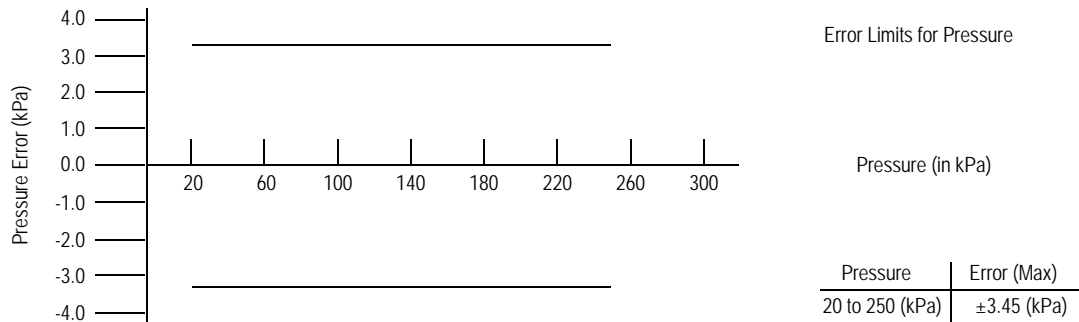

SURFACE MOUNTING INFORMATION

Minimum Recommended Footprint for Super Small Outline Packages

Surface mount board layout is a critical portion of the total design. The footprint for the semiconductor package must be the correct size to ensure proper solder connection interface between the board and the package. With the correct pad geometry, the packages will self-align when subjected to a solder reflow process. It is always recommended to fabricate boards with a solder mask layer to avoid bridging and/or shorting between solder pads, especially on tight tolerances and/or tight layouts.

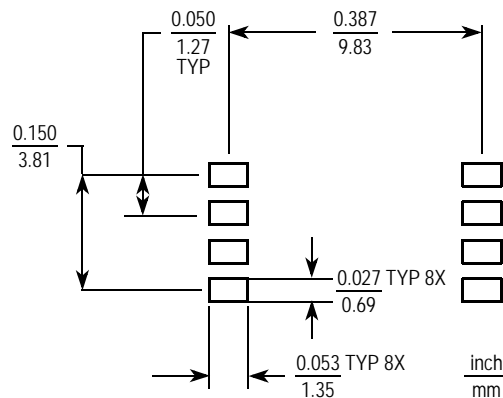
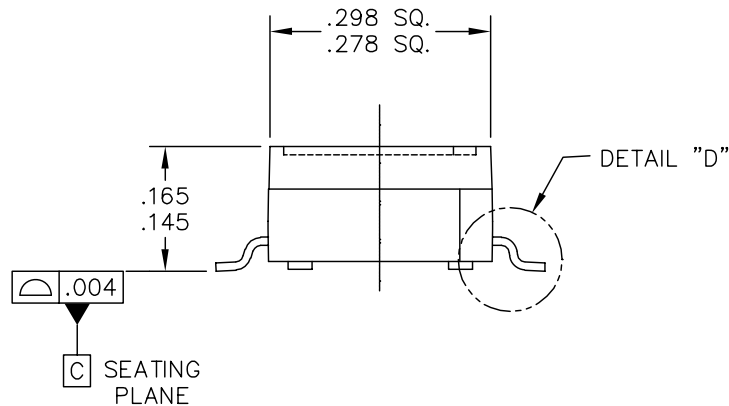
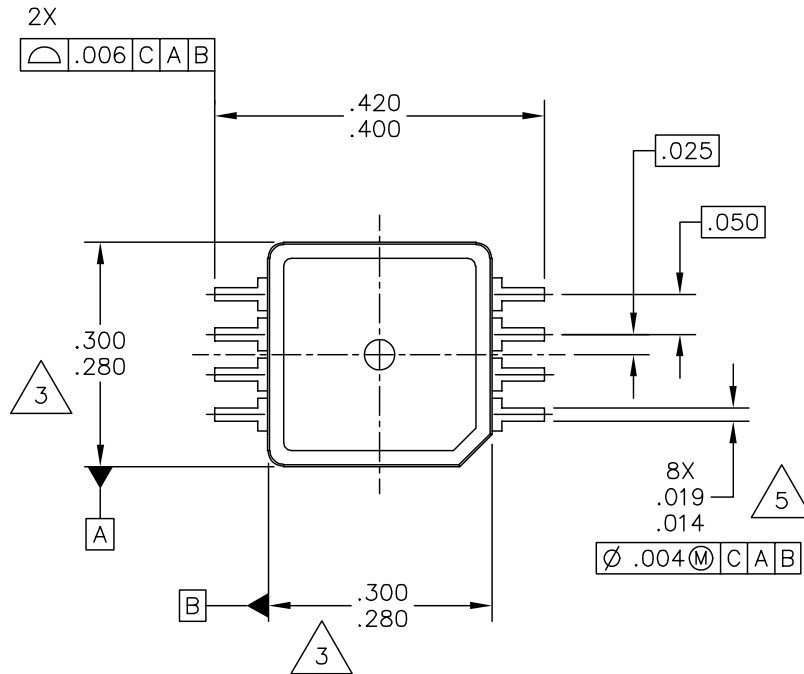

Figure 5. SSOP Footprint (Case 1317 and 1317A)

PACKAGE DIMENSIONS



© FREESCALE SEMICONDUCTOR, INC. ALL RIGHTS RESERVED.		MECHANICAL OUTLINE		PRINT VERSION NOT TO SCALE	
TITLE: 8 LEAD SSOP	DOCUMENT NO: 98ARH99066A			REV: F	
	CASE NUMBER: 1317-04			24 MAY 2005	
	STANDARD: NON-JEDEC				

**CASE 1317-04
 ISSUE F
 SUPER SMALL OUTLINE PACKAGE**

PACKAGE DIMENSIONS

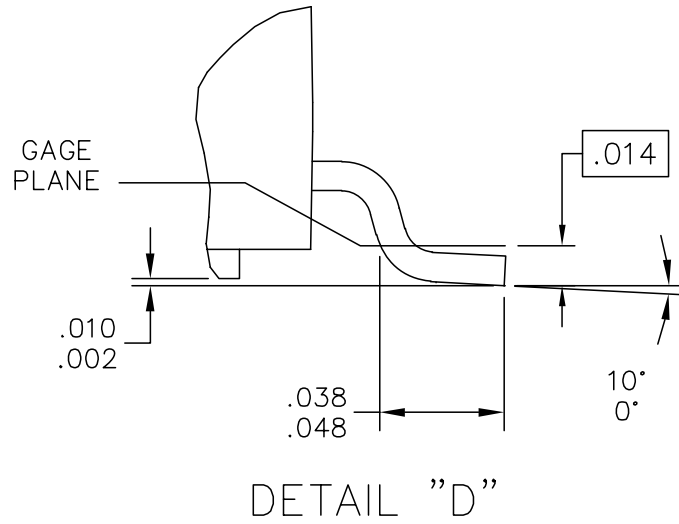

© FREESCALE SEMICONDUCTOR, INC. ALL RIGHTS RESERVED.		MECHANICAL OUTLINE		PRINT VERSION NOT TO SCALE	
TITLE:	8 LEAD SSOP	DOCUMENT NO: 98ARH99066A		REV: F	
		CASE NUMBER: 1317-04		24 MAY 2005	
		STANDARD: NON-JEDEC			

PAGE 2 OF 3

**CASE 1317-04
ISSUE F
SUPER SMALL OUTLINE PACKAGE**

MPXH6250A

PACKAGE DIMENSIONS

NOTES:

1. ALL DIMENSIONS IN INCHES.
2. DIMENSIONING AND TOLERANCING PER ASME Y14.5M-1994.
3. DIMENSIONS DO NOT INCLUDE MOLD FLASH OR PROTRUSIONS.
MOLD FLASH OR PROTRUSION SHALL NOT EXCEED .006 INCHES PER SIDE.
4. ALL VERTICAL SURFACES TO BE 5° MAXIMUM.
5. DIMENSION DOES NOT INCLUDE DAMBAR PROTRUSION.
ALLOWABLE DAMBAR PROTRUSION SHALL BE .008 INCHES MAXIMUM.

© FREESCALE SEMICONDUCTOR, INC. ALL RIGHTS RESERVED.		MECHANICAL OUTLINE		PRINT VERSION NOT TO SCALE	
TITLE: 8 LEAD SSOP	DOCUMENT NO: 98ARH99066A		REV: F		
	CASE NUMBER: 1317-04		24 MAY 2005		
	STANDARD: NON-JEDEC				

PAGE 3 OF 3

**CASE 1317-04
ISSUE F
SUPER SMALL OUTLINE PACKAGE**

MPXH6250A

PACKAGE DIMENSIONS

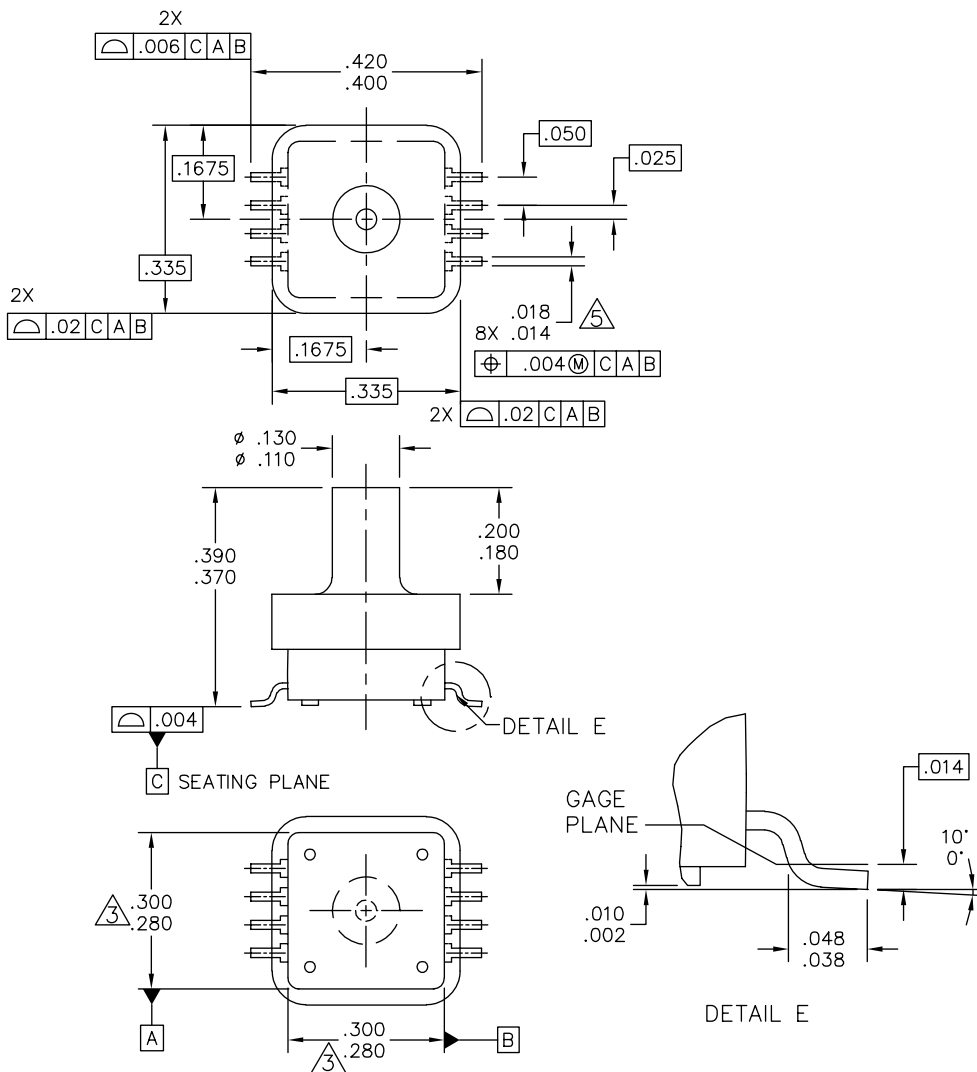

© FREESCALE SEMICONDUCTOR, INC. ALL RIGHTS RESERVED.	MECHANICAL OUTLINE	PRINT VERSION NOT TO SCALE
TITLE: 8 LD, PORTED SSOP	DOCUMENT NO: 98ARH99089A	REV: D
	CASE NUMBER: 1317A-04	26 OCT 2006
	STANDARD: NON-JEDEC	

**CASE 1317A-04
ISSUE D
SUPER SMALL OUTLINE PACKAGE**

PACKAGE DIMENSIONS

NOTES:

1. ALL DIMENSIONS IN INCHES.
2. DIMENSIONING AND TOLERANCING PER ASME Y14.5M-1994.
3. DIMENSIONS DO NOT INCLUDE MOLD FLASH OR PROTRUSIONS.
MOLD FLASH OR PROTRUSION SHALL NOT EXCEED .006 INCHES PER SIDE.
4. ALL VERTICAL SURFACES TO BE 5° MAXIMUM.
5. DIMENSION DOES NOT INCLUDE DAMBAR PROTRUSION.
ALLOWABLE DAMBAR PROTRUSION SHALL BE .008 INCHES MAXIMUM.

© FREESCALE SEMICONDUCTOR, INC. ALL RIGHTS RESERVED.	MECHANICAL OUTLINE	PRINT VERSION NOT TO SCALE	
TITLE: 8 LD, PORTED SSOP	DOCUMENT NO: 98ARH99089A	REV: D	
	CASE NUMBER: 1317A-04	26 OCT 2006	
	STANDARD: NON-JEDEC		

PAGE 2 OF 2

**CASE 1317A-04
ISSUE D
SUPER SMALL OUTLINE PACKAGE**

MPXH6250A

How to Reach Us:

Home Page:

www.freescale.com

Web Support:

<http://www.freescale.com/support>

USA/Europe or Locations Not Listed:

Freescale Semiconductor, Inc.
Technical Information Center, EL516
2100 East Elliot Road
Tempe, Arizona 85284
1-800-521-6274 or +1-480-768-2130
www.freescale.com/support

Europe, Middle East, and Africa:

Freescale Halbleiter Deutschland GmbH
Technical Information Center
Schatzbogen 7
81829 Muenchen, Germany
+44 1296 380 456 (English)
+46 8 52200080 (English)
+49 89 92103 559 (German)
+33 1 69 35 48 48 (French)
www.freescale.com/support

Japan:

Freescale Semiconductor Japan Ltd.
Headquarters
ARCO Tower 15F
1-8-1, Shimo-Meguro, Meguro-ku,
Tokyo 153-0064
Japan
0120 191014 or +81 3 5437 9125
support.japan@freescale.com

Asia/Pacific:

Freescale Semiconductor China Ltd.
Exchange Building 23F
No. 118 Jianguo Road
Chaoyang District
Beijing 100022
China
+86 10 5879 8000
support.asia@freescale.com

For Literature Requests Only:

Freescale Semiconductor Literature Distribution Center
1-800-441-2447 or +1-303-675-2140
Fax: +1-303-675-2150
LDCForFreescaleSemiconductor@hibbertgroup.com

Information in this document is provided solely to enable system and software implementers to use Freescale Semiconductor products. There are no express or implied copyright licenses granted hereunder to design or fabricate any integrated circuits or integrated circuits based on the information in this document.

Freescale Semiconductor reserves the right to make changes without further notice to any products herein. Freescale Semiconductor makes no warranty, representation or guarantee regarding the suitability of its products for any particular purpose, nor does Freescale Semiconductor assume any liability arising out of the application or use of any product or circuit, and specifically disclaims any and all liability, including without limitation consequential or incidental damages. "Typical" parameters that may be provided in Freescale Semiconductor data sheets and/or specifications can and do vary in different applications and actual performance may vary over time. All operating parameters, including "Typicals", must be validated for each customer application by customer's technical experts. Freescale Semiconductor does not convey any license under its patent rights nor the rights of others. Freescale Semiconductor products are not designed, intended, or authorized for use as components in systems intended for surgical implant into the body, or other applications intended to support or sustain life, or for any other application in which the failure of the Freescale Semiconductor product could create a situation where personal injury or death may occur. Should Buyer purchase or use Freescale Semiconductor products for any such unintended or unauthorized application, Buyer shall indemnify and hold Freescale Semiconductor and its officers, employees, subsidiaries, affiliates, and distributors harmless against all claims, costs, damages, and expenses, and reasonable attorney fees arising out of, directly or indirectly, any claim of personal injury or death associated with such unintended or unauthorized use, even if such claim alleges that Freescale Semiconductor was negligent regarding the design or manufacture of the part.

Freescale™ and the Freescale logo are trademarks of Freescale Semiconductor, Inc. All other product or service names are the property of their respective owners.

© Freescale Semiconductor, Inc. 2009. All rights reserved.

