

SERIES
DESIGNATES PRESSURE
 L - LOW PRESSURE (IN H₂O)
 - NO DESIGNATION (PSI)
PRESSURE RANGE
 04, 10 IN H₂O
 0.3, 01, 05, 15, 30,
 60, 100, 150 PSI

ACCURACY GRADE
 C - COMMERCIAL GRADE
 H - HIGH GRADE

PORT OPTION
 F - AXIAL
 - NO PORT/O-RING SEAL

PRESSURE REFERENCE
 G - GAGE

CATALOG LISTINGS	
CPCL04GC	CPC15GFC
CPCL04GFC	CPC15GFH
CPCL10GFC	(9)
CPCL10GFH	CPC30GFC
CPCL10GH	CPC30GFH
(1)	CPC60GFH
CPC0.3GFC	(9)
CPC0.3GFH	CPC60GFC
CPC01GFC	CPC100GFH
CPC01GFH	CPC100GFC
CPC01GH	CPC100GFC
CPC05GFC	CPC150GFC
CPC05GFC	CPC150GFH
CPC05GFH	SCDA121 CPCL04GFC
CPC05GH	

G - STYLE (GAGE)	PERFORMANCE AT 25°C AND 12±0.01 Vdc (UNLESS OTHERWISE STATED)						UNITS	FULL SCALE PRESSURE PSI	OVER PRESSURE PSI
	C-GRADE			H-GRADE					
	MIN	NOM	MAX	MIN	NOM	MAX			
NULL OFFSET (0 PSIG) (L04 LISTING)	-2	0	2	N/A	N/A	N/A	mVdc		
NULL OFFSET (0 PSIG), ALL LISTINGS EXCEPT L04	-1	0	1	-0.5	0	0.5	mV		
4 IN H ₂ O (P1>P2) (L04 LISTING)	23	25	27	N/A	N/A	N/A	mVdc	4 IN H ₂ O	3
4 IN H ₂ O (P1>P2) (SCDA121 CPCL04GFC)	23	25	27	N/A	N/A	N/A	mVdc	4 IN H ₂ O	5
10 IN H ₂ O (P1>P2) (L10 LISTING)	19	20	21	19.5	20	20.5	mVdc	10 IN H ₂ O	5
0.3 PSI SPAN (P1>P2)	19	20	21	19.5	20	20.5	mVdc	0.3	5
1 PSI SPAN (P1>P2)	17	18	19	17.5	18	18.5	mVdc	1	5
5 PSI SPAN (P1>P2)	57	60	63	59	60	61	mVdc	5	15
15 PSI SPAN (P1>P2)	85	90	95	89	90	91	mVdc	15	45
30 PSI SPAN (P1>P2)	85	90	95	89	90	91	mVdc	30	90
60 PSI SPAN (P1>P2)	85	90	95	89	90	91	mVdc	60	180
100 PSI SPAN (P1>P2)	95	100	105	99	100	101	mVdc	100	250
150 PSI SPAN (P1>P2)	85	90	95	89	90	91	mVdc	150	250
NULL SHIFT OVER TEMPERATURE (0-25, 25-70 °C) (L04)	---	---	±1	---	---	±.5	mV		
SPAN SHIFT OVER TEMPERATURE (0-25, 25-70 °C) (L04)	---	---	±2	---	---	±1	% SPAN		
COMBINED LINEARITY AND HYSTERESIS (L04)	---	0.25	1	---	0.25	0.5	% SPAN		

GENERAL OPERATING CHARACTERISTICS	ALL PRESSURES AND GRADES			UNITS
	MIN	NOM	MAX	
EXCITATION VOLTAGE	3	12	16	Vdc
SUPPLY CURRENT	---	---	3.5	mA
INPUT RESISTANCE	5	---	---	K-OHMS
OUTPUT RESISTANCE	---	3	---	K-OHMS
OPERATING TEMPERATURE	-25	---	85	°C
STORAGE TEMPERATURE	-40	---	125	°C

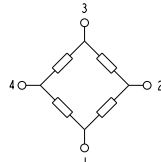

EQUIVALENT CIRCUIT

PIN OUT	
1	-V EXCITATION
2	+ OUTPUT SIGNAL
3	+V EXCITATION
4	- OUTPUT SIGNAL

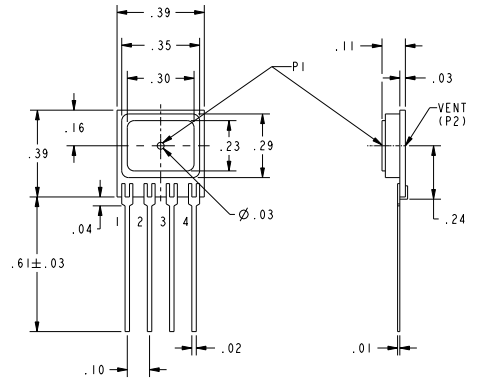

G HOUSING

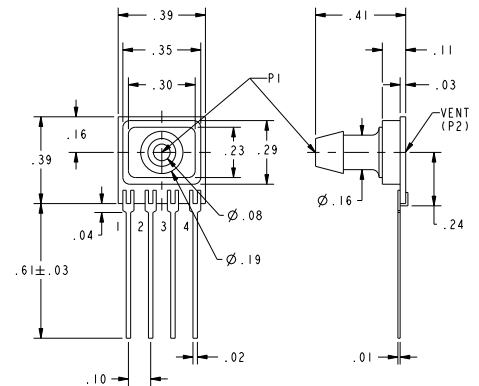

GF HOUSING

NOTES

- SPAN IS THE ALGEBRAIC DIFFERENCE BETWEEN THE OUTPUT AT FULL SCALE PRESSURE AND THE OFFSET OUTPUT
- TEMPERATURE ERROR IS CALCULATED WITH RESPECT TO 25°C
- LINEARITY IS MEASURED AT 1/2 FULL SCALE PRESSURE USING BEST STRAIGHT LINE FIT
- THE OUTPUT OF THE SENSOR IS PROPORTIONAL, RATIO-METRIC, TO THE EXCITATION VOLTAGE. THE EXCITATION MAY VARY BETWEEN 3 TO 16 Vdc. ALL SPECIFICATIONS WILL NOMINALLY BE CHANGED BY THE RATIO OF V_{EXCITATION}/12.0 Vdc
- LIMIT SOLDERING TO 315°C FOR LESS THAN 10 SECONDS
- PIN 1 IS IDENTIFIED BY THE DOT ON THE HOUSING AS SHOWN ON THE VARIOUS DRAWINGS
- APPLY PRESSURE TO PORT INDICATED ON THE DRAWINGS SHOWN
- SENSORS ARE OPERATIONAL OVER VACUUM PRESSURE RANGE
- INPUT MEDIA RESTRICTED TO DRY GASES ONLY
- THE L04 LISTING HAS A TEMPERATURE SHIFT RANGE FROM 0 TO 25°C AND 25 TO 50°C

UNLESS OTHERWISE SPECIFIED TOLERANCES ARE:	<input checked="" type="checkbox"/> DECIMAL	<input type="checkbox"/> FRACTIONAL	<input type="checkbox"/> MIXED	DRAWN	TRF	02APRO1
NO PLACE	.X	±.040	±1	CHECK	SAV	02APRO1
ONE PLACE	.X	±.030	±0.4	THIS DRAWING COVERS A PROPRIETARY ITEM AND IS THE PROPERTY OF HONEYWELL. THIS DRAWING IS NOT TO BE COPIED OR USED WITHOUT THE PERMISSION OF HONEYWELL.		
TWO PLACE	.XX	±.015	±0.15			
THREE PLACE	.XXX	±.005	±			
ANGLES	±	±	±			
RAW MATERIAL-COMMERCIAL STANDARD				THIRD ANGLE PROJECTION		
DIMENSIONS ARE TO BE MET BEFORE PROTECTIVE COATINGS ARE APPLIED				3D PTC ASME Y14.5M-1994		

Honeywell

PRESSURE SENSOR

SIZE	DWG TYPE	DRAWING NAME	REV
C	I	CPC GAGE SERIES CHART 1	14
SCALE	3:1	WEIGHT	SHEET 1 OF 1