

Infrared Products Selection Guide

July 2002

Light Emitting Diodes

Transmissive Opto Sensors

Reflective Opto Sensors

Photosensors

- Electrical and Optical Specifications
- Absolute Maximum Ratings
- Package Specifications
- Ordering Information
- Glossary of Terms
- Frequently Asked Questions

www.fairchildsemi.com/infrared

Across the board. Around the world.™

FAIRCHILD
SEMICONDUCTOR®

Table of Contents

Fairchild Semiconductor is a leader in the design and production of infrared components, offering a broad range of standard products, as well as custom devices, to meet your specific design requirements. Fairchild's infrared product portfolio includes light emitting diodes, photosensors (phototransistors, photodarlingtons, photodiodes, and OPTOLOGIC® sensors), as well as transmissive and reflective opto sensors.

For the latest information and data sheets available, please visit our Web site at:

www.fairchildsemi.com/infrared

For information on how we can customize products to meet your needs, contact the sales representative or distributor in your area. They can be found at:

www.fairchildsemi.com/cf/sales_contacts

Plastic Light Emitting Diodes

T-1 (3 mm) Diode Package	1
T-1 ^{3/4} (5 mm) Diode Package	1
TO-46 (Plastic) Diode Package	2
Sidelooker Diode Package	3
Thin Sidelooker Diode Package	3

Surface Mount Light Emitting Diodes

T- ^{3/4} (2 mm) Diode Package	4
PLCC-2 Diode Package	4

Hermetic Light Emitting Diodes

TO-46 Diode Package (Convex Lens)	5
TO-46 Diode Package (Flat Lens)	6

Plastic Silicon Photosensors

T-1 (3 mm) Detector Package	7
T-1 ^{3/4} (5 mm) Detector Package	7
TO-18 Detector (Plastic) Package	8
Sidelooker Detector Package	9
Thin Sidelooker Detector Package	9
Sidelooker Detector Package (No Lens)	10
TO-92 Detector Package	10
T-1 ^{3/4} (5 mm) Diode Package	11

Plastic Silicon OPTOLOGIC® Photosensors

Sidelooker OPTOLOGIC® Package	12
-------------------------------	----

Surface Mount Silicon Photosensors

T- ^{3/4} (2 mm) Detector Package	13
PLCC-2 Detector Package	13

Hermetic Silicon Photosensors

TO-18 Detector Package (Convex Lens)	14
TO-18 Detector Package (Flat Lens)	15
TO-18 OPTOLOGIC® Package	16

Transmissive Opto Sensors

Slotted Switch H21	17
Slotted Switch Logic H21	18
Slotted Switch H22	19
Slotted Switch Logic H22	20
Slotted Switch QVA	21
Slotted Switch QVB	22
Slotted Switch 5 mm Gap, 10 mm Lead Spacing	23
Slotted Switch 5 mm Gap, 9 mm Lead Spacing	23
Slotted Switch Logic 5 mm	24
Slotted Switch High Profile	25
Slotted Switch Wide Gap	26
Slotted Switch MOC	27
Slotted Switch 8 mm Gap	28
Surface Mount Opto Interrupter QCK	29
Surface Mount Switch 2 mm Gap	30
Slotted Switch Horizontal with Wires	31
Slotted Switch Logic with Wires	31

Reflective Opto Sensors

Reflective Arrowhead with Dust Cover	32
Reflective Arrowhead without Dust Cover	32
Reflective Focusing Sensor PCB Mount	33
Reflective Non-focusing Sensor PCB Mount	33
Reflective Surface Mount Package	34
Reflective Arrowhead with Dust Cover, Wires	35
Reflective Arrowhead without Dust Cover, Wires	35

Ordering Information

	36
--	----

Glossary of Terms

	37
--	----

Frequently Asked Questions

	38
--	----

Index

	39
--	----

Plastic Light Emitting Diodes

T-1 (3 mm) Diode Package

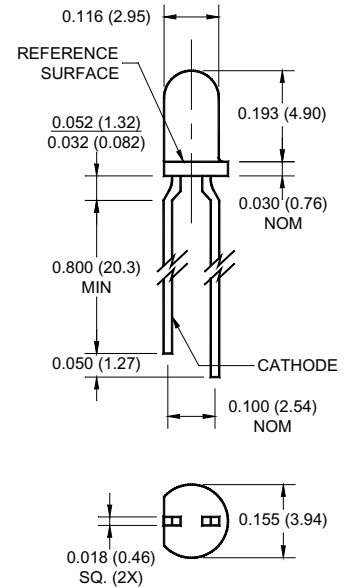

All dimensions are in inches (millimeters)

Part Number	I_e @ 100 mA I_F (mW/sr)		V_F @ 100 mA I_F (V) max	I_R @ 5 V V_R (μ A) max	Emission Angle in Degrees ($^\circ$) @ 1/2 Power	Wavelength (nm) λ_p
	min	max				
QEC112	6	30	1.7	10	24	940
QEC113	14	-	1.7	10	24	940
QEC121	14	-	1.9	10	16	880
QEC122	27	80	1.9	10	16	880
QEC123	39	-	1.9	10	16	880

T-1 3/4 (5 mm) Diode Package

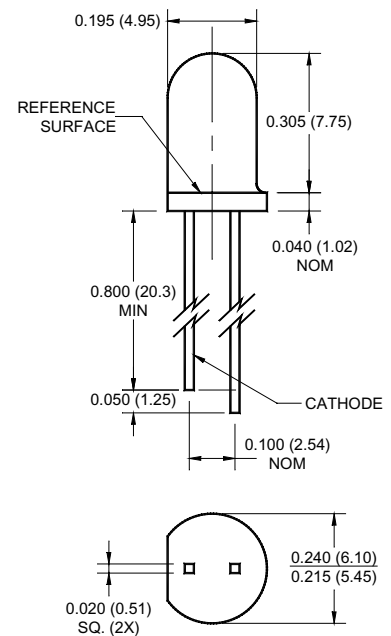

All dimensions are in inches (millimeters)

Part Number	I_e @ 100 mA I_F (mW/sr)		V_F @ 100 mA I_F (V) max	I_R @ 5 V V_R (μ A) max	Emission Angle in Degrees ($^\circ$) @ 1/2 Power	Wavelength (nm) λ_p
	min	max				
QED233	10	50	1.6	10	40	940
QED234	27	-	1.6	10	40	940
QED633	15	-	1.6	10	55	940
QED634	20	-	1.6	10	55	940
QED121	16	40	1.9	10	18	880
QED122	32	100	1.9	10	18	880
QED123	50	-	1.9	10	18	880
QED221	10	20	1.9	10	40	880
QED222	16	32	1.9	10	40	880
QED223	25	-	1.9	10	40	880

Plastic Light Emitting Diodes

TO-46 (Plastic) Diode Package

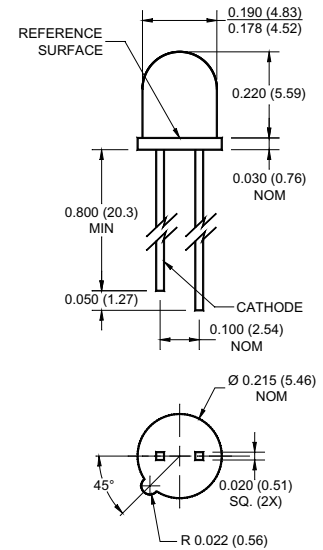

Part Number	I_e @ 100 mA I_F (mW/sr)		V_F @ 100 mA I_F (V)	I_R @ 5 V V_R (μ A)	Emission Angle in Degrees ($^\circ$) @ 1/2 Power	Wavelength (nm) λ_p
	min	max	max	max		
QED422	10	40	1.9	10	30	880
QED423	20	-	1.9	10	30	880
QED522	20	80	1.9	10	20	880
QED523	40	-	1.9	10	20	880

All dimensions are in inches (millimeters)

Absolute Maximum Ratings

PARAMETER	QEC	QED
Temperature		
T_{OPR}	-40 to +100°C	-40 to +100°C
T_{STG}	-40 to +100°C	-40 to +100°C
T_{SOL-I}	240°C for 5 sec	240°C for 5 sec
T_{SOL-F}	260°C for 10 sec	260°C for 10 sec
LED		
I_F	50 mA	100 mA
V_R	5.0 V	5.0 V
P_D	100 mW	200 mW

Plastic Light Emitting Diodes

Sidelooker Diode Package

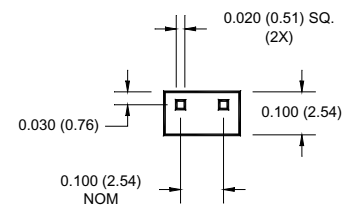
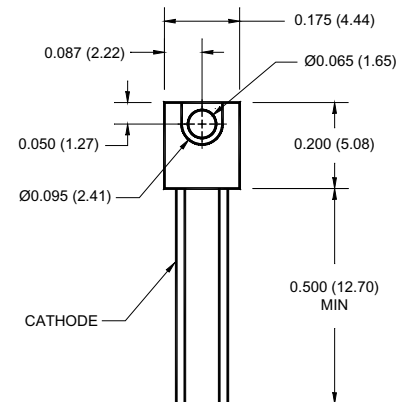

All dimensions are in inches (millimeters)

Part Number	$I_e @ 100 \text{ mA } I_F$ (mW/sr)		$V_F @ 100 \text{ mA } I_F$ (V)	$I_R @ 5 \text{ V } V_R$ (μA)	Emission Angle in Degrees ($^\circ$) @ 1/2 Power	Wavelength (nm) λ_p
	min	max	max	max		
QEE113	3	12	1.7	10	50	940
QEE122	4	16	1.9	10	50	880
QEE123	8	-	1.9	10	50	880

Thin Sidelooker Diode Package

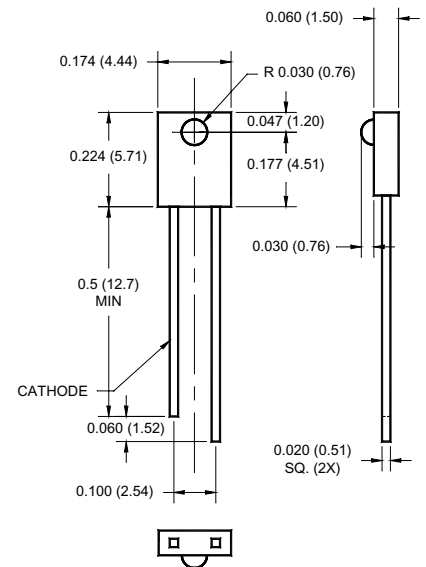

All dimensions are in inches (millimeters)

Part Number	$I_e @ 100 \text{ mA } I_F$ (mW/sr)		$V_F @ 100 \text{ mA } I_F$ (V)	$I_R @ 5 \text{ V } V_R$ (μA)	Emission Angle in Degrees ($^\circ$) @ 1/2 Power	Wavelength (nm) λ_p
	min	max	max	max		
QEE213	2	-	1.7	10	50	940

Surface Mount Light Emitting Diodes

T-3/4 (2 mm) Diode Package

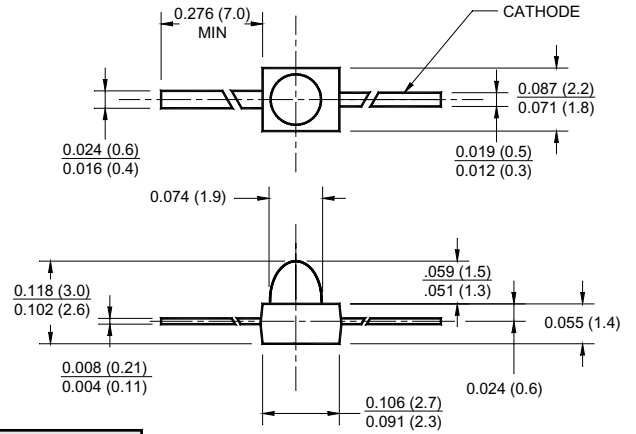
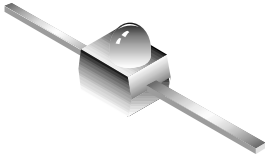

Part Number	I_e @ 100 mA I_F (mW/sr)		V_F @ 100 mA I_F (V)	I_R @ 5 V V_R (μ A)	Emission Angle in Degrees ($^\circ$) @ 1/2 Power	Wavelength (nm) λ_p
	min	max	max	max		
QEB363	8	-	1.7	100	24	940
QEB373	16	-	1.9	100	24	880

All dimensions are in inches (millimeters)

PLCC-2 Diode Package

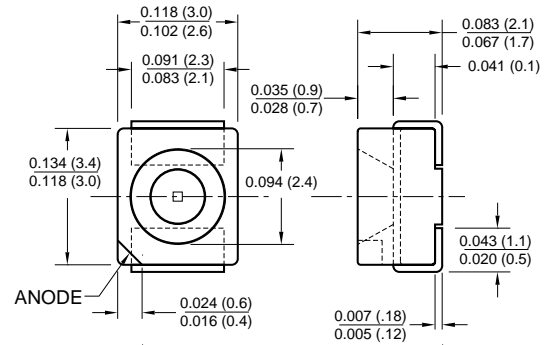
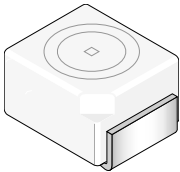

Part Number	I_e @ 100 mA I_F (mW/sr)		V_F @ 100 mA I_F (V)		I_R @ 5 V V_R (μ A)	Emission Angle in Degrees ($^\circ$) @ 1/2 Power	Wavelength (nm) λ_p
	min	max	typ	max	max		
QEB421	4	8	1.5	1.8	1.0	120	880
QEB441	2	6	2.1	-	10.0	120	730

All dimensions are in inches (millimeters)

Absolute Maximum Ratings	PARAMETER	QEB3XX	QEB4XX	QEE	
	Temperature				
	T_{OPR}	-40 to +85 $^\circ$ C	-55 to +100 $^\circ$ C	-40 to +100 $^\circ$ C	
	T_{STG}	-40 to +85 $^\circ$ C	-55 to +100 $^\circ$ C	-40 to +100 $^\circ$ C	
	T_{SOL-I}	240 $^\circ$ C for 5 sec	NA	240 $^\circ$ C for 5 sec	
	T_{SOL-F}	260 $^\circ$ C for 10 sec	260 $^\circ$ C for 10 sec	260 $^\circ$ C for 10 sec	
	LED				
	I_F	50 mA	100 mA	50 mA	
	V_R	5.0 V	5.0 V	5.0 V	
	P_D	100 mW	180 mW	100 mW	

Hermetic Light Emitting Diodes

TO-46 Diode Package (Convex Lens)

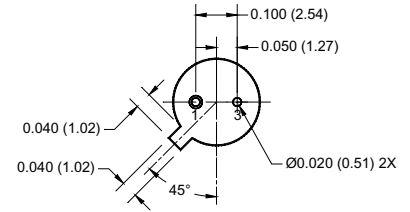
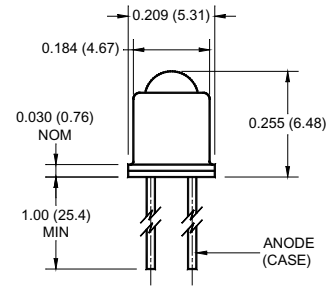
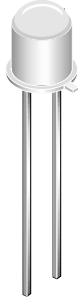

Part Number	$P_O @ 100 \text{ mA } I_F$ (mW)		$V_F @ 100 \text{ mA } I_F$ (V)	$I_R @ 3 \text{ V } V_R$ (μA)	Emission Angle in Degrees ($^\circ$) @ 1/2 Power	Wavelength (nm) λ_p
	min	max	max	max		
1N6264	6.00	-	1.7	10	16	940
CGX14	5.40	-	1.7	10	16	940
CGX16	1.50	-	1.7	10	16	940
LED55B	3.50	-	1.7	10	16	940
LED55C	5.40	-	1.7	10	16	940
LED56	1.50	-	1.7	10	16	940
F5D1	12.00	-	1.8	10	16	880
F5D2	9.00	-	1.8	10	16	880
F5D3	10.50	-	1.8	10	16	880

All dimensions are in inches (millimeters)

Hermetic Light Emitting Diodes

TO-46 Diode Package (Flat Lens)

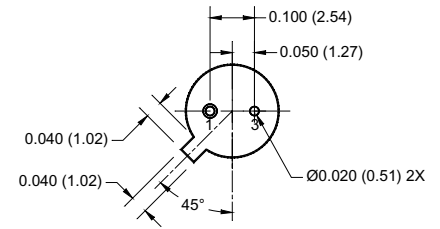
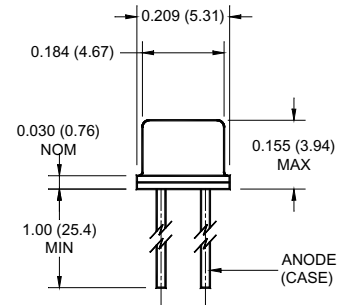
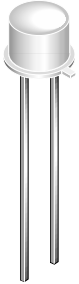

Part Number	$P_O @ 100 \text{ mA } I_F$ (mW)		$V_F @ 100 \text{ mA } I_F$ (V)	$I_R @ 3 \text{ V } V_R$ (μA)	Emission Angle in Degrees ($^\circ$) @ 1/2 Power	Wavelength (nm) λ_p
	min	max	max	max		
1N6265	6.00	-	1.7	10	80	940
CQX15	5.40	-	1.7	10	80	940
CQX17	1.50	-	1.7	10	80	940
LED55BF	3.50	-	1.7	10	80	940
LED55CF	5.40	-	1.7	10	80	940
LED56F	1.50	-	1.7	10	80	940
F5E1	12.00	-	1.8	10	80	880
F5E2	9.00	-	1.8	10	80	880
F5E3	10.50	-	1.8	10	80	880

All dimensions are in inches (millimeters)

Absolute Maximum Ratings	PARAMETER 1N, CQX, LED, F5	
	Temperature	
	T_{OPR}	-65 to +125 $^\circ\text{C}$
	T_{STG}	-65 to +150 $^\circ\text{C}$
	T_{SOL-L}	240 $^\circ\text{C}$ for 5 sec
	T_{SOL-F}	260 $^\circ\text{C}$ for 10 sec
	LED	
	I_F	100 mA
	I_R	3.0 V
	P_D	170 mW

Plastic Silicon Photosensors

T-1 (3 mm) Detector Package

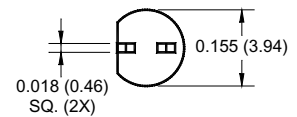
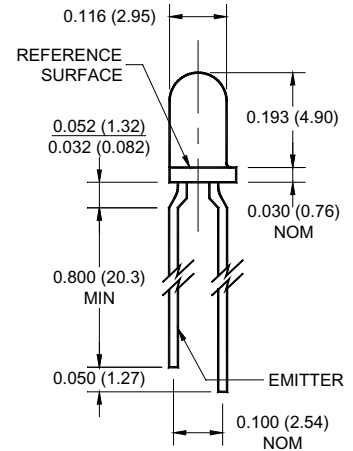

All dimensions are in inches (millimeters)

Part Number	V _{CE} (V)	Test Conditions		I _C (ON) (mA)		BV _{CEO} (V) max	I _{CEO} @ 10 V V _{CE} (nA) max	Sensor Type
		E _e (mW/cm ²)	λ _p (nm)	min	max			
QSC112	5	0.5	880 AlGaAs	1.00	4.00	30	100	Phototransistor
QSC113	5	0.5	880 AlGaAs	2.40	9.60	30	100	Phototransistor
QSC114	5	0.5	880 AlGaAs	4.00	–	30	100	Phototransistor
QSC133	5	0.25	880 AlGaAs	8.00	–	30	100	Photodarlington

T-1 3/4 (5 mm) Detector Package

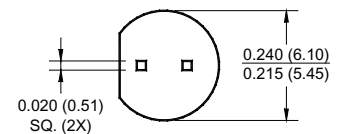
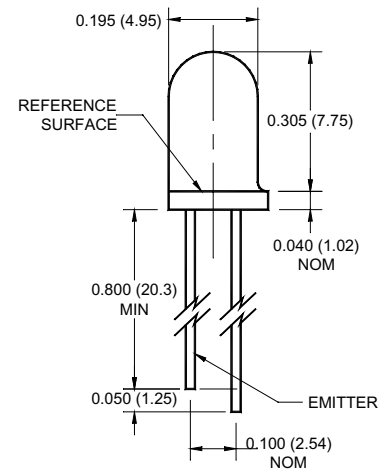

All dimensions are in inches (millimeters)

Part Number	V _{CE} (V)	Test Conditions		I _C (ON) (mA)		BV _{CEO} (V) max	I _{CEO} @ 10 V V _{CE} (nA) max	Sensor Type
		E _e (mW/cm ²)	λ _p (nm)	min	max			
QSD122	5	0.5	880 AlGaAs	1.00	6.00	30	100	Phototransistor
QSD123	5	0.5	880 AlGaAs	4.00	16.00	30	100	Phototransistor
QSD124	5	0.5	880 AlGaAs	6.00	–	30	100	Phototransistor

Plastic Silicon Photosensors

TO-18 Detector (Plastic Package)

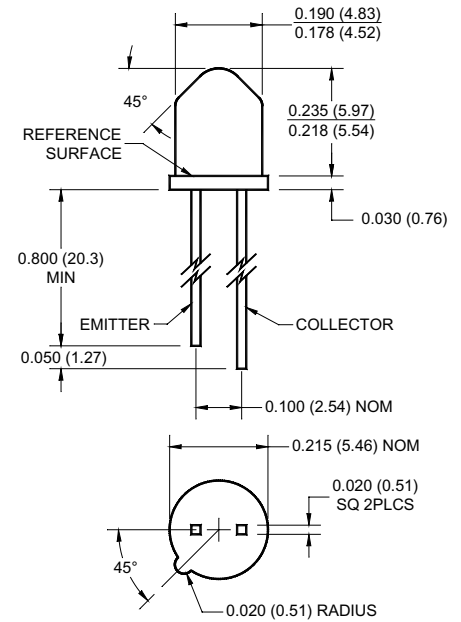

All dimensions are in inches (millimeters)

Part Number	V _{CE} (V)	Test Conditions		I _c (ON) (mA)		BV _{CEO} (V) max	I _{CEO} @ 10 V V _{CE} (nA) max	Sensor Type
		E _e (mW/cm ²)	λ _p (nm)	min	max			
QSD722	5	0.5	880 AlGaAs	0.60	3.80	30	100	Phototransistor
QSD723	5	0.5	880 AlGaAs	2.50	10.00	30	100	Phototransistor
QSD724	5	0.5	880 AlGaAs	3.50	–	30	100	Phototransistor
QSD733	5	0.25	880 AlGaAs	10.00	–	30	100	Photodarlington

Absolute Maximum Ratings

PARAMETER QSC, QSD

Temperature

T _{OPR}	–40 to +100°C
T _{STG}	–40 to +100°C
T _{SOL-I}	240°C for 5 sec
T _{SOL-F}	260°C for 10 sec

Sensor

V _{CEO}	30 V
V _{ECC}	5.0 V
P _D	100 mW

Plastic Silicon Photosensors

Sidelooker Detector Package

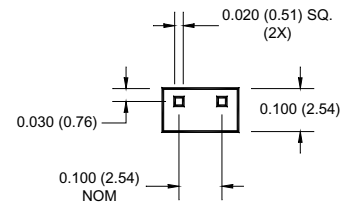
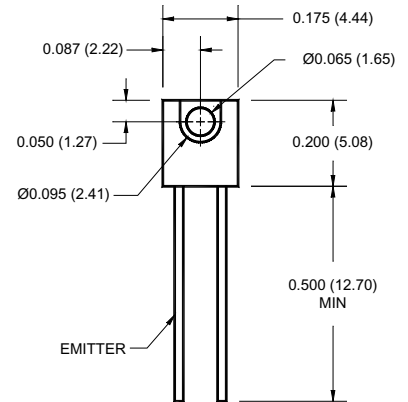

All dimensions are in inches (millimeters)

Part Number	Test Conditions			I_C (ON) (mA)		BV_{CEO} (V)	I_{CEO} @ 10 V V_{CE} (nA)	Sensor Type
	V_{CE} (V)	E_e (mW/cm ²)	λ_p (nm)	min	max	max	max	
QSE113	5	0.5	880 AlGaAs	0.25	1.50	30	100	Phototransistor
QSE114	5	0.5	880 AlGaAs	1.00	-	30	100	Phototransistor
QSE122	5	0.5	880 AlGaAs	3.00	12.00	30	100	Phototransistor
QSE133	5	0.25	880 AlGaAs	9.00	-	30	100	Photodarlington

Thin Sidelooker Detector Package

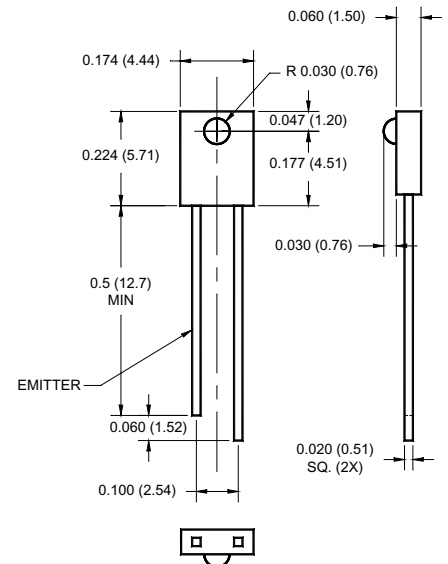

All dimensions are in inches (millimeters)

Part Number	Test Conditions			I_C (ON) (mA)		BV_{CEO} (V)	I_{CEO} @ 25 V V_{CE} (nA)	Sensor Type
	V_{CE} (V)	E_e (mW/cm ²)	λ_p (nm)	min	max	max	max	
QSE213	5	0.5	950 GaAs	0.2	1.50	30	100	Phototransistor
QSE214	5	0.5	950 GaAs	1.0	-	30	100	Phototransistor

Plastic Silicon Photosensors

Sidelooker Detector Package (No Lens)

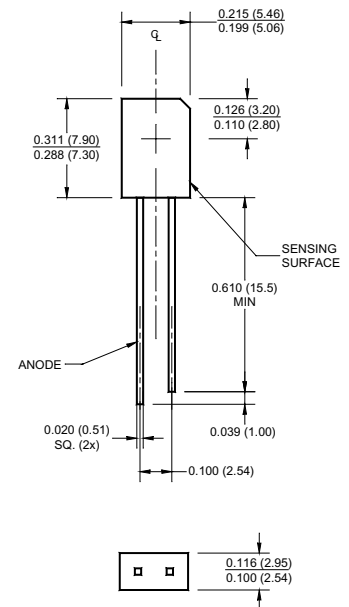

All dimensions are in inches (millimeters)

Part Number	Test Conditions			I_L (μA)		I_{RD} @ 10 V V_R (nA) max	Radiant Sensitive Area (mm^2)	Sensor Type
	V_R (V)	E_e (mW/cm^2)	λ_p (nm)	min	max			
QSE773	5	1.0	940 GaAs	30.0	-	30	2.71 x 2.71	Photodiode

TO-92 Detector Package

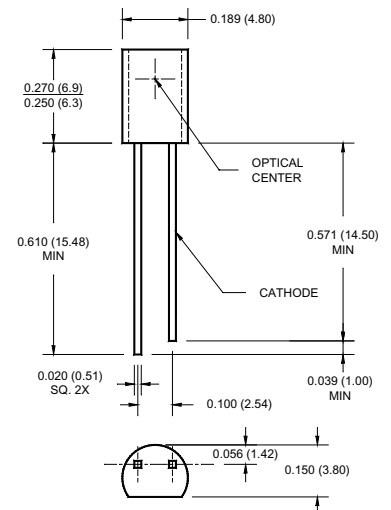

All dimensions are in inches (millimeters)

Part Number	Test Conditions			I_L (μA)		I_{RD} @ 10 V V_R (nA) max	Radiant Sensitive Area (mm^2)	Sensor Type
	V_R (V)	E_e (mW/cm^2)	λ_p (nm)	min	max			
QSE973	5	1.0	940 GaAs	30.0	-	30	2.71 x 2.71	Photodiode

Absolute Maximum Ratings	PARAMETER	QSE11X, 21X	
	Temperature		
	T_{OPR}	-40 to +100°C	
	T_{STG}	-40 to +100°C	
	T_{SOL-H}	240°C for 5 sec	
	T_{SOL-F}	260°C for 10 sec	
	Sensor		
V_{CEO}	30 V		
V_{ECO}	5.0 V		
P_D	100 mW		

Absolute Maximum Ratings	PARAMETER	QSE773, 993	
	Temperature		
	T_{OPR}	-40 to +85°C	
	T_{STG}	-40 to +85°C	
	T_{SOL-H}	240°C for 5 sec	
	T_{SOL-F}	260°C for 10 sec	
	Diode		
I_F	NA		
V_R	30 V		
P_D	150 mW		

Plastic Silicon Photosensors

T-1³/₄ (5 mm) Diode Package

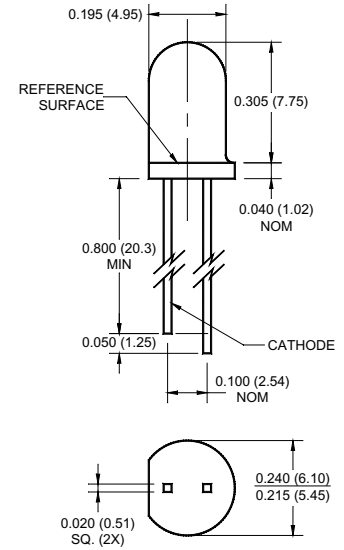

Part Number	Test Conditions			I_L (μA)		I_{RD} @ 20 V V_R (nA) max	Radiant Sensitive Area (mm^2)	Sensor Type
	V_R (V)	E_e (mW/cm^2)	λ_p (nm)	min	max			
QSD2030	5	0.5	950 GaAs	15.0	—	5	1.0 x 1.0	Photodiode

All dimensions are in inches (millimeters)

Absolute Maximum Ratings	PARAMETER	QSD	
	Temperature		
	T_{OPR}	-40 to +100°C	
	T_{STG}	-40 to +100°C	
	T_{SOLH}	240°C for 5 sec	
	T_{SOLF}	260°C for 10 sec	
	Diode		
	I_F	NA	
	V_R	50 V	
	P_D	100 mW	

Plastic Silicon OPTOLOGIC® Photosensors

Sidelooker OPTOLOGIC® Package

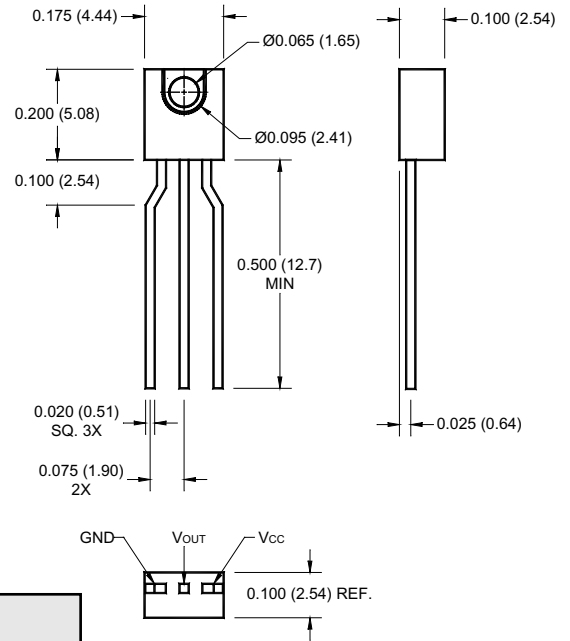

Part Number	Test Conditions (nm) λ_p	E_{e+} (mW/cm ²) max	E_{e+}/E_{e-} typ	V_{OL} (V) max	I_{CC} (mA) max	Sensor Type
QSE156	880 AlGaAs	0.250	1.2	0.40	5	Buffer Totem Pole
QSE157	880 AlGaAs	0.250	1.2	0.40	5	Inverter Totem Pole
QSE158	880 AlGaAs	0.250	1.2	0.40	5	Buffer Open Collector
QSE159	880 AlGaAs	0.250	1.2	0.40	5	Inverter Open Collector

All dimensions are in inches (millimeters)

Absolute Maximum Ratings	PARAMETER	QSE	
	Temperature		
	T_{OPR}	-40 to +85°C	
	T_{STG}	-40 to +100°C	
	T_{SOLH}	240°C for 5 sec	
	T_{SOLF}	260°C for 10 sec	
	Sensor		
	I_D	50 mA	
	V_{CC}	16 V	
	P_D	100 mW	

Surface Mount Silicon Photosensors

T-3/4 (2 mm) Detector Package

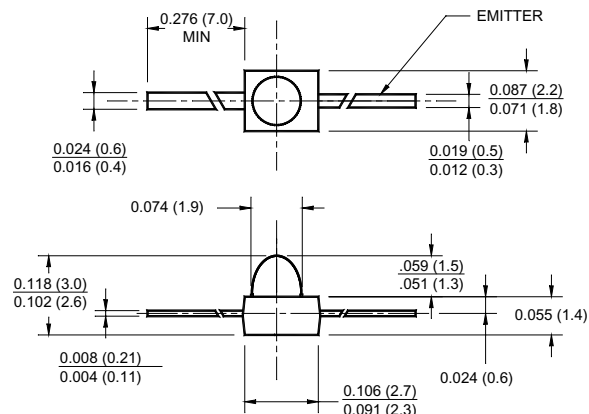
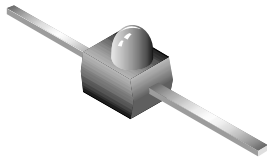

Part Number	Test Conditions			I_C (ON)		BV_{CEO}	I_{CEO} @ 10 V V_{CE}	Sensor Type
	V_{CE} (V)	E_e (mW/cm ²)	λ_p (nm)	min	max	max	max	
QSB363	5	0.5	880 AlGaAs	0.7	-	30	100	Phototransistor

All dimensions are in inches (millimeters)

PLCC-2 Detector Package

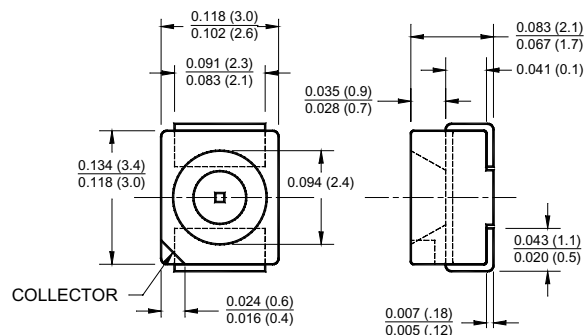
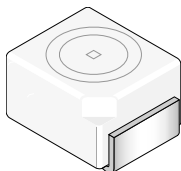

Part Number	Test Conditions			I_C (ON)		BV_{CEO}	I_{CEO} @ 25 V V_{CE}	Sensor Type
	V_{CE} (V)	E_e (mW/cm ²)	λ_p (nm)	min	max	max	max	
QSB320	5	0.1	880 AlGaAs	16	-	30	200	Phototransistor

All dimensions are in inches (millimeters)

Absolute Maximum Ratings	PARAMETER	QSB320	QSB363	
	Temperature			
	T_{OPR}	-55 to +100°C	-40 to +85°C	
	T_{STG}	-55 to +100°C	-40 to +85°C	
	T_{SOL-I}	NA	240°C for 5 sec	
	T_{SOL-F}	260°C for 10 sec	260°C for 10 sec	
	Sensor			
	V_{CEO}	35 V	30 V	
	V_{ECO}	5.0 V	5.0 V	
	P_D	165 mW	100 mW	

Hermetic Silicon Photosensors

TO-18 Detector Package (Convex Lens)

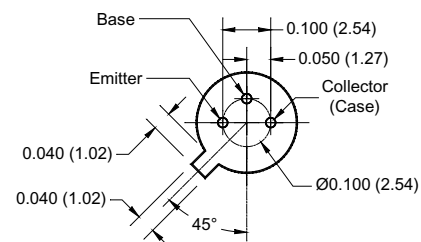
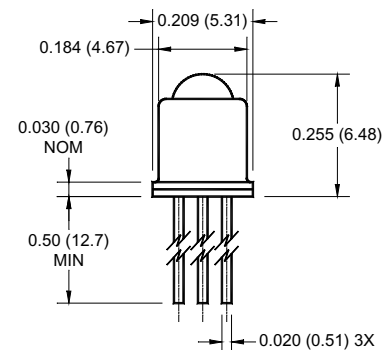
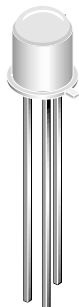

Part Number	V _{CE} (V)	Test Conditions		I _C (ON) (mA)		BV _{CEO} (V) max	I _{CEO} @ 10 V V _{CE} (nA) max	Sensor Type
		E _o (mW/cm ²)	λ _p (nm)	min	max			
BPW36	5	0.5	940 GaAs	1.00	-	30	100	Phototransistor
BPW37	5	0.5	940 GaAs	0.50	-	30	100	Phototransistor
L14G1	5	0.5	940 GaAs	1.00	-	30	100	Phototransistor
L14G2	5	0.5	940 GaAs	0.50	-	30	100	Phototransistor
L14G3	5	0.5	940 GaAs	2.00	-	30	100	Phototransistor
L14P1	5	0.5	940 GaAs	6.50	-	30	100	Phototransistor
L14P2	5	0.5	940 GaAs	13.0	-	30	100	Phototransistor

Part Number	V _{CE} (V)	Test Conditions		I _C (ON) (mA)		BV _{CEO} (V) max	I _{CEO} @ 12 V V _{CE} (nA) max	Sensor Type
		E _o (mW/cm ²)	λ _p (nm)	min	max			
BPW38	5	0.05	940 GaAs	3.00	-	25	100	Photodarlington
L14F1	5	0.05	940 GaAs	3.00	-	25	100	Photodarlington
L14F2	5	0.05	940 GaAs	1.00	-	25	100	Photodarlington

All dimensions are in inches (millimeters)

PARAMETER	BPW38, L14F	L14G/P, BPW36/7
	Absolute Maximum Ratings	
Temperature		
T _{OPR}	-65 to +125°C	-65 to +125°C
T _{STG}	-65 to +150°C	-65 to +150°C
T _{SOL-H}	240°C for 5 sec	240°C for 5 sec
T _{SOL-F}	260°C for 10 sec	260°C for 10 sec
Sensor		
V _{CEO}	25 V	30 V
V _{CBO}	25 V	40 V
V _{EBO}	12.0 V	5.0 V
P _D	300 mW	300 mW

Hermetic Silicon Photosensors

TO-18 Detector Package (Flat Lens)

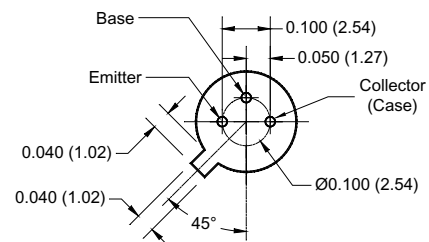
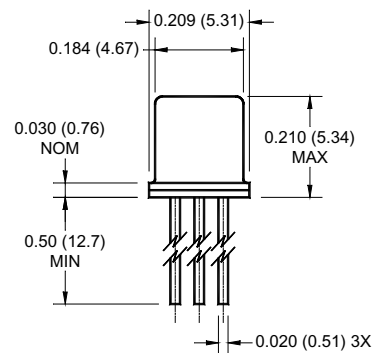
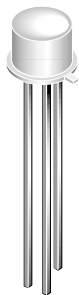

Part Number	V _{CE} (V)	Test Conditions		I _{C (ON)} (mA)		BV _{CEO} (V) max	I _{CEO} @ 20 V V _{CE} (nA) max	Sensor Type
		E _e (mW/cm ²)	λ _p (nm)	min	max			
L14C1	5	0.5	940 GaAs	0.16	-	30	100	Phototransistor
L14C2	5	0.5	940 GaAs	0.08	-	30	100	Phototransistor

Part Number	V _{CE} (V)	Test Conditions		I _{C (ON)} (mA)		BV _{CEO} (V) max	I _{CEO} @ 20 V V _{CE} (nA) max	Sensor Type
		E _e (mW/cm ²)	λ _p (nm)	min	max			
L14N1	5	0.5	940 GaAs	1.00	-	30	100	Phototransistor
L14N2	5	0.5	940 GaAs	2.00	-	30	100	Phototransistor

All dimensions are in inches (millimeters)

Absolute Maximum Ratings	PARAMETER	L14C/N	
	Temperature		
	T _{OPR}	-65 to +125°C	
	T _{STG}	-65 to +150°C	
	T _{SOLH}	240°C for 5 sec	
	T _{SOLF}	260°C for 10 sec	
	Sensor		
	V _{CEO}	30 V	
	V _{CBO}	40 V	
	V _{EBO}	5.0 V	
P _D	300 mW		

Hermetic Silicon Photosensors

TO-18 OPTOLOGIC® Package

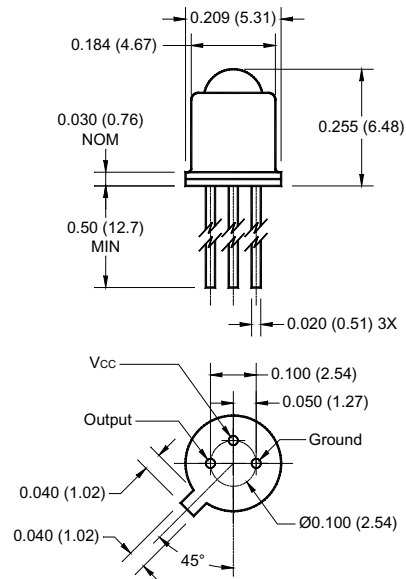
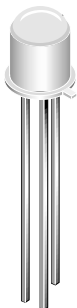

All dimensions are in inches (millimeters)

Part Number	Test Conditions (nm) λ_p	E_{e+} (mW/cm ²) max	E_{e+}/E_{e-} typ	V_{OL} (V) max	I_{CC} (mA) max	Sensor Type
QSA156	880 AlGaAs	0.250	1.2	0.40	5	Buffer Totem Pole
QSA157	880 AlGaAs	0.250	1.2	0.40	5	Inverter Totem Pole
QSA158	880 AlGaAs	0.250	1.2	0.40	5	Buffer Open Collector
QSA159	880 AlGaAs	0.250	1.2	0.40	5	Inverter Open Collector

Absolute Maximum Ratings	PARAMETER	QSA	
	Temperature		
	T_{OPR}	-55 to +105°C	
	T_{STG}	-65 to +125°C	
	T_{SOL-I}	240°C for 5 sec	
	T_{SOL-F}	260°C for 10 sec	
	Sensor		
	I_D	50 mA	
	V_{CC}	16 V	
	P_D	250 mW	

Transmissive Opto Sensors

Slotted Switch H21 (Analog – Standard Resolution)

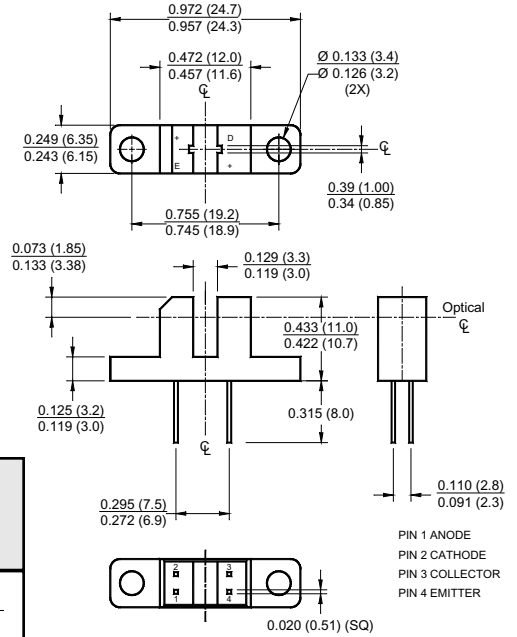
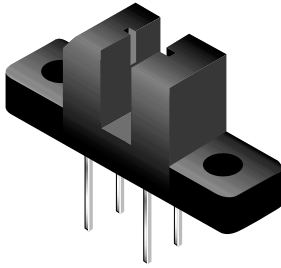

Part Number	Test Conditions		I _C (ON) (mA) min	BV _{CEO} (V) min	Output	Aperture Width (mm)		Gap Width (mm)
	I _F (mA)	V _{CE} (V)				Emitter	Sensor	
CNY28	20	10	0.2	30	Phototransistor	0.94	0.94	3.15
CNY29	20	10	2.50	25	Photodarlington	0.94	0.94	3.15
H21A1	20	5	1.00	30	Phototransistor	0.94	0.94	3.15
H21A2	20	5	2.00	30	Phototransistor	0.94	0.94	3.15
H21A3	20	5	4.00	30	Phototransistor	0.94	0.94	3.15
H21A4	20	5	1.00	55	Phototransistor	0.94	0.94	3.15
H21A5	20	5	2.00	55	Phototransistor	0.94	0.94	3.15
H21A6	20	5	4.00	55	Phototransistor	0.94	0.94	3.15
H21B1	10	1.5	7.50	30	Photodarlington	0.94	0.94	3.15
H21B2	10	1.5	14.00	30	Photodarlington	0.94	0.94	3.15
H21B3	10	1.5	25.00	30	Photodarlington	0.94	0.94	3.15
H21B4	10	1.5	7.50	55	Photodarlington	0.94	0.94	3.15
H21B5	10	1.5	14.00	55	Photodarlington	0.94	0.94	3.15
H21B6	10	1.5	25.00	55	Photodarlington	0.94	0.94	3.15

All dimensions are in inches (millimeters)

PARAMETER	CNY28	CNY29	H21A1-A3	H21A4-A6	H21B1-B3	H21B4-B6
	Temperature					
T _{OPR}	-55 to +85°C	-55 to +85°C	-55 to +100°C	-55 to +100°C	-55 to +100°C	-55 to +100°C
T _{STG}	-55 to +85°C	-55 to +85°C	-55 to +100°C	-55 to +100°C	-55 to +100°C	-55 to +100°C
T _{SOL-H}	240°C for 5 sec for all devices					
T _{SOL-F}	260°C for 10 sec for all devices					
Input Diode						
I _F	60 mA	60 mA	60 mA	60 mA	60 mA	60 mA
V _R	3.0 V	3.0 V	6.0 V	6.0 V	6.0 V	6.0 V
P _D	100 mW	100 mW	100 mW	100 mW	100 mW	100 mW
Output Transistor						
V _{CEO}	30 V	30 V	30 V	55 V	30 V	55 V
V _{ECO}	4.5 V	6.0 V	4.5 V	4.5 V	6.0 V	6.0 V
I _C	20 mA	40 mA	20 mA	20 mA	40 mA	40 mA
P _D	150 mW	150 mW	150 mW	150 mW	150 mW	150 mW

Absolute Maximum Ratings

Transmissive Opto Sensors

Slotted Switch Logic H21 (OPTOLOGIC® – Standard Resolution)

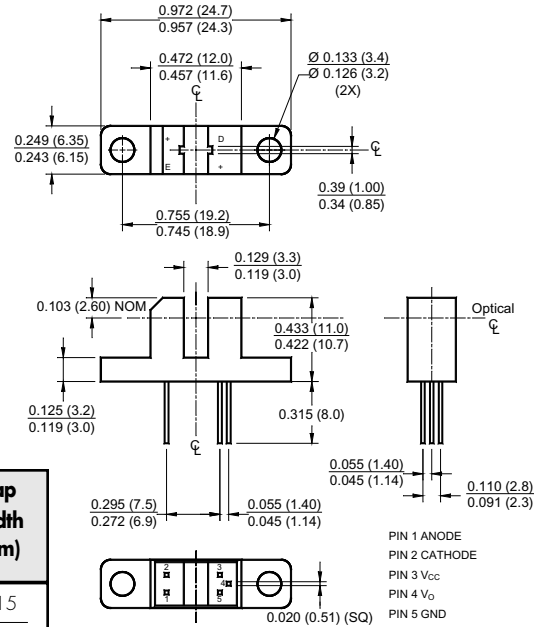
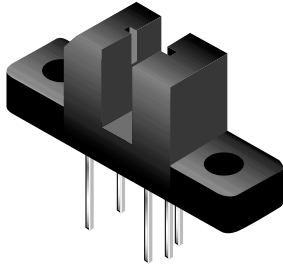

Part Number	Test Conditions V _{CC} (V)	I _{F+} (mA) max	I _{CC} (mA) max	Output	Aperture Width (mm)		Gap Width (mm)
					Emitter	Sensor	
H21LTB	5	15	5.0	Buffer Totem Pole	0.94	0.94	3.15
H21LTI	5	15	5.0	Inverter Totem Pole	0.94	0.94	3.15
H21LOB	5	15	5.0	Buffer Open Collector	0.94	0.94	3.15
H21LOI	5	15	5.0	Inverter Open Collector	0.94	0.94	3.15

All dimensions are in inches (millimeters)

Absolute Maximum Ratings	PARAMETER	H21L	
	Temperature		
	T _{OPR}	-40 to +85°C	
	T _{STG}	-40 to +85°C	
	T _{SOL-H}	240°C for 5 sec	
	T _{SOL-F}	260°C for 10 sec	
	Input Diode		
	I _F	50 mA	
	V _R	6.0 V	
	P _D	100 mW	
	Output Optologic®		
	I _O	50 mA	
	V _{CC}	4.0 – 16 V	
V _O	30 V		
P _D	150 mW		

Transmissive Opto Sensors

Slotted Switch H22 (Analog – Standard Resolution)

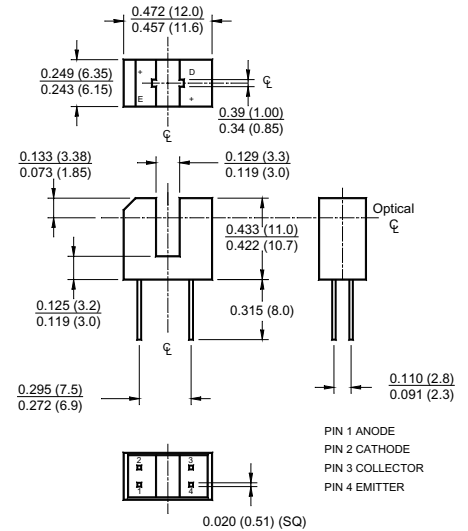
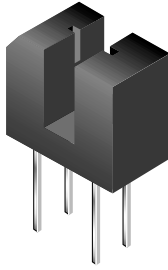

Part Number	Test Conditions		I _C (ON) (mA) min	BV _{CEO} (V) min	Output	Aperture Width (mm)		Gap Width (mm)
	I _F (mA)	V _{CE} (V)				Emitter	Sensor	
CNY36	20	10	0.2	30	Phototransistor	0.94	0.94	3.15
H22A1	20	5	1.00	30	Phototransistor	0.94	0.94	3.15
H22A2	20	5	2.00	30	Phototransistor	0.94	0.94	3.15
H22A3	20	5	4.00	30	Phototransistor	0.94	0.94	3.15
H22A4	20	5	1.00	55	Phototransistor	0.94	0.94	3.15
H22A5	20	5	2.00	55	Phototransistor	0.94	0.94	3.15
H22A6	20	5	4.00	55	Phototransistor	0.94	0.94	3.15
H22B1	10	1.5	7.50	30	Photodarlington	0.94	0.94	3.15
H22B2	10	1.5	14.00	30	Photodarlington	0.94	0.94	3.15
H22B3	10	1.5	25.00	30	Photodarlington	0.94	0.94	3.15
H22B4	10	1.5	7.50	55	Photodarlington	0.94	0.94	3.15
H22B5	10	1.5	14.00	55	Photodarlington	0.94	0.94	3.15
H22B6	10	1.5	25.00	55	Photodarlington	0.94	0.94	3.15

All dimensions are in inches (millimeters)

PARAMETER	CNY	H22A1-A3	H22A4-A6	H21B1-B3	H22B4-B6
	Temperature				
T _{OPR}	-55 to +85°C	-55 to +100°C	-55 to +100°C	-55 to +100°C	-55 to +100°C
T _{STG}	-55 to +85°C	-55 to +100°C	-55 to +100°C	-55 to +100°C	-55 to +100°C
T _{SOL-H}	240°C for 5 sec for all devices				
T _{SOL-F}	260°C for 10 sec for all devices				
Input Diode					
I _F	60 mA	60 mA	60 mA	60 mA	60 mA
V _R	3.0 V	6.0 V	6.0 V	6.0 V	6.0 V
P _D	100 mW	100 mW	100 mW	100 mW	100 mW
Output Transistor					
V _{CEO}	30 V	30 V	55 V	30 V	55 V
V _{ECC}	4.5 V	4.5 V	4.5 V	6.0 V	6.0 V
I _C	20 mA	20 mA	20 mA	40 mA	40 mA
P _D	150 mW	150 mW	150 mW	150 mW	150 mW

Absolute Maximum Ratings

Transmissive Opto Sensors

Slotted Switch Logic H22 (OPTOLOGIC® – Standard Resolution)

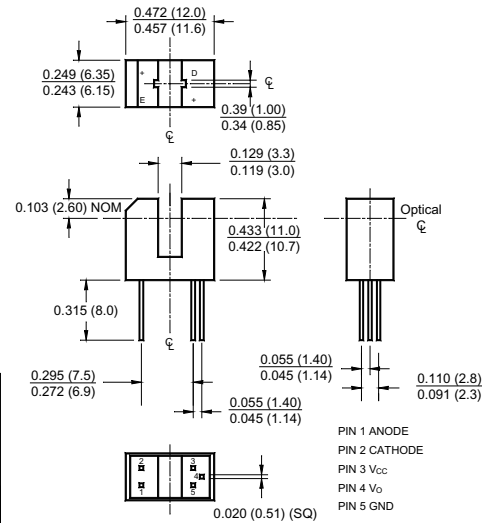
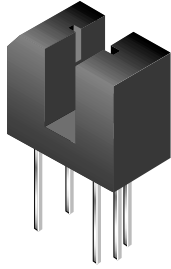

All dimensions are in inches (millimeters)

Part Number	Test Conditions V_{CC} (V)	I_{F+} (mA) max	I_{CC} (mA) max	Output	Aperture Width (mm)		Gap Width (mm)
					Emitter	Sensor	
H22LTB	5	15	5.0	Buffer Totem Pole	0.94	0.94	3.15
H22LTI	5	15	5.0	Inverter Totem Pole	0.94	0.94	3.15
H22LOB	5	15	5.0	Buffer Open Collector	0.94	0.94	3.15
H22LOI	5	15	5.0	Inverter Open Collector	0.94	0.94	3.15

Absolute Maximum Ratings	PARAMETER	H22L	
	Temperature		
	T_{OPR}	-40 to +85°C	
	T_{STG}	-40 to +85°C	
	T_{SOL-H}	240°C for 5 sec	
	T_{SOL-F}	260°C for 10 sec	
	Input Diode		
	I_F	50 mA	
	V_R	6.0 V	
	P_D	100 mW	
	Output Optologic®		
	I_O	50 mA	
	V_{CC}	4.0 – 16 V	
V_O	30 V		
P_D	150 mW		

Transmissive Opto Sensors

Slotted Switch QVA (Analog)

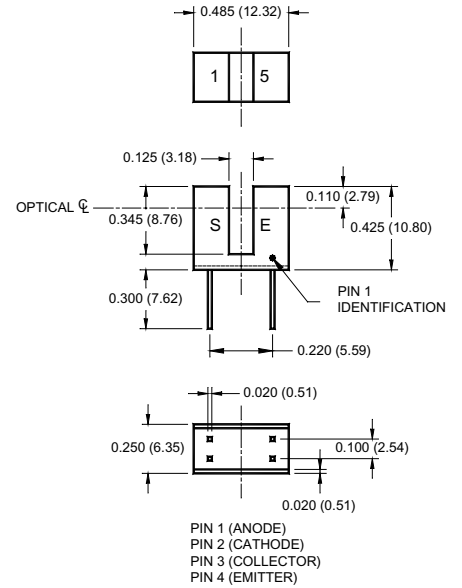
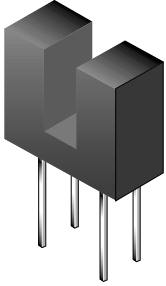

(Standard Resolution)

Part Number	Test Conditions		I_C (ON) (mA) min	BV_{CEO} (V) min	Output	Aperture Width (mm)		Gap Width (mm)
	I_F (mA)	V_{CE} (V)				Emitter	Sensor	
QVA11134	20	5	1.00	30	Phototransistor	1.27	1.27	3.18

(High Resolution)

Part Number	Test Conditions		I_C (ON) (mA) min	BV_{CEO} (V) min	Output	Aperture Width (mm)		Gap Width (mm)
	I_F (mA)	V_{CE} (V)				Emitter	Sensor	
QVA21114	20	5	0.20	30	Phototransistor	0.25	0.25	3.18

All dimensions are in inches (millimeters)

Transmissive Opto Sensors

Slotted Switch QVB (Analog)

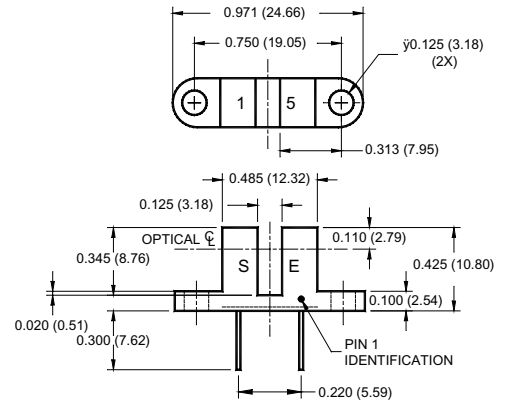
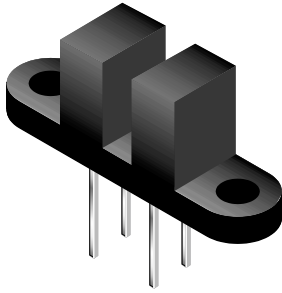

(Standard Resolution)

Part Number	Test Conditions		I_C (ON) (mA) min	BV_{CEO} (V) min	Wavelength λ_p (nm)	Aperture Width (mm)		Gap Width (mm)
	I_F (mA)	V_{CE} (V)				Emitter	Sensor	
QVB11134	20	5	1.00	30	Phototransistor	1.27	1.27	3.18

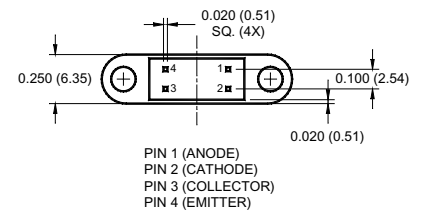

(High Resolution)

Part Number	Test Conditions		I_C (ON) (mA) min	BV_{CEO} (V) min	Output	Aperture Width (mm)		Gap Width (mm)
	I_F (mA)	V_{CE} (V)				Emitter	Sensor	
QVB21114	20	5	0.20	30	Phototransistor	0.25	0.25	3.18

All dimensions are in inches (millimeters)

Absolute Maximum Ratings	PARAMETER	QVA, QVB	
	Temperature		
	T_{OPR}	-40 to +85°C	
	T_{STG}	-40 to +85°C	
	T_{SOL-H}	240°C for 5 sec	
	T_{SOL-F}	260°C for 10 sec	
	Input Diode		
	I_F	5 mA	
	V_R	6.0 V	
	P_D	100 mW	
	Output Transistor		
	V_{CEO}	30.0 V	
V_{ECO}	4.5 V		
I_C	20 mA		
P_D	150 mW		

Transmissive Opto Sensors

Slotted Switch 5 mm Gap, 10 mm lead spacing (Analog – High Resolution)

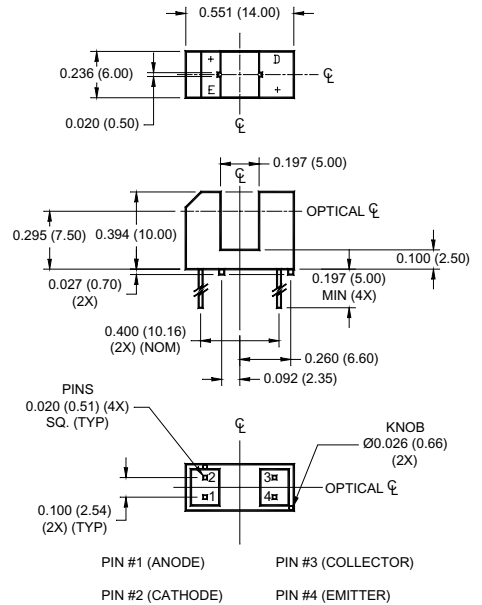
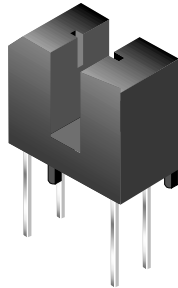

All dimensions are in inches (millimeters)

Part Number	Test Conditions		I_C (ON) (mA) min	BV_{CEO} (V) min	Output	Aperture Width (mm)		Gap Width (mm)
	I_F (mA)	V_{CE} (V)				Emitter	Sensor	
QVE00832	20	10	0.50	30	Phototransistor	0.50	0.50	5.00

Slotted Switch 5 mm Gap, 9 mm lead spacing (Analog – High Resolution)

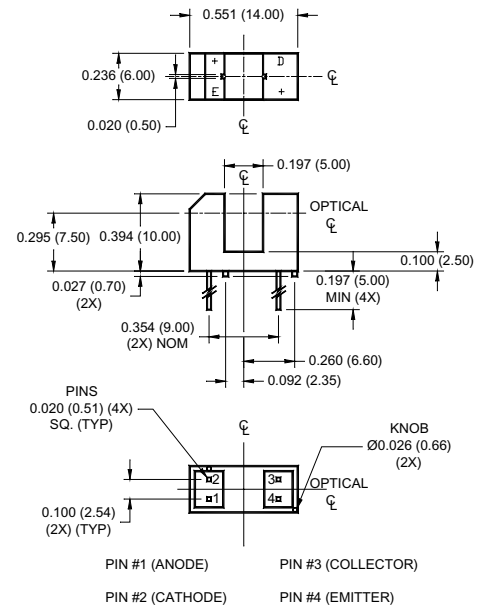
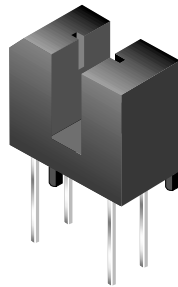

All dimensions are in inches (millimeters)

Part Number	Test Conditions		I_C (ON) (mA) min	BV_{CEO} (V) min	Output	Aperture Width (mm)		Gap Width (mm)
	I_F (mA)	V_{CE} (V)				Emitter	Sensor	
QVE00118	20	10	0.50	30	Phototransistor	0.50	0.50	5.00

Transmissive Opto Sensors

Slotted Switch Logic 5 mm (OPTOLOGIC® – High Resolution)

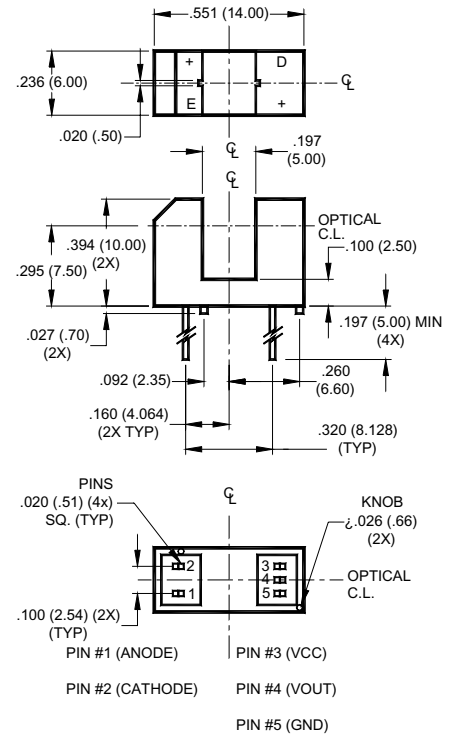
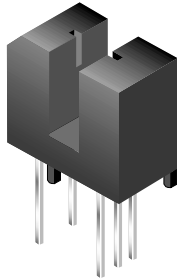

Part Number	Test Conditions V_{CC} (V)	I_{CC} (mA) max	Output	Aperture Width (mm)		Gap Width (mm)
				Emitter	Sensor	
QVE00120	5	5.0	Buffer Open Collector	0.50	0.50	5.00

All dimensions are in inches (millimeters)

Absolute Maximum Ratings	PARAMETER	QVE	
	Temperature		
	T_{OPR}	-55 to +100°C	
	T_{STG}	-55 to +100°C	
	T_{SOL-H}	240°C for 5 sec	
	T_{SOL-F}	260°C for 10 sec	
	Input Diode		
	I_F	5 mA	
	V_R	6.0 V	
	P_D	100 mW	
Output Transistor			
V_{CEO}	30.0 V		
V_{ECO}	4.5 V		
I_C	20 mA		
P_D	150 mW		

Absolute Maximum Ratings	PARAMETER	QVE00120	
	Temperature		
	T_{OPR}	-40 to +85°C	
	T_{STG}	-40 to +85°C	
	T_{SOL-H}	240°C for 5 sec	
	T_{SOL-F}	260°C for 10 sec	
	Input Diode		
	I_F	50 mA	
	V_R	6.0 V	
	P_D	100 mW	
Output Optologic®			
I_O	50 mA		
V_{CC}	4.5 – 16 V		
V_O	30 V		
P_D	150 mW		

Transmissive Opto Sensors

Slotted Switch High Profile (Analog – Low Resolution)

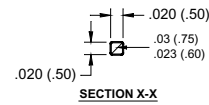
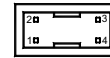
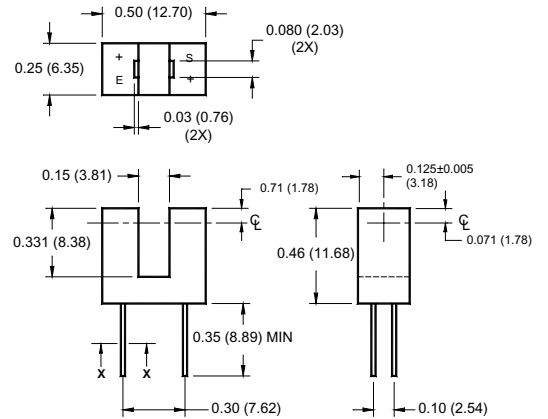
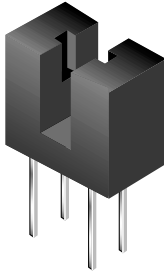

PIN 1 ANODE
PIN 2 CATHODE
PIN 3 COLLECTOR
PIN 4 EMITTER

All dimensions are in inches (millimeters)

Part Number	Test Conditions		I _C (ON) (mA) min	BV _{CEO} (V) min	Output	Aperture Width (mm)		Gap Width (mm)
	I _F (mA)	V _{CE} (V)				Emitter	Sensor	
QVE11233	20	5	0.50	30	Phototransistor	2.0	2.0	3.81

Absolute Maximum Ratings

PARAMETER	QVE
Temperature	
T _{OPR}	-40 to +85°C
T _{STG}	-40 to +85°C
T _{SOL-H}	240°C for 5 sec
T _{SOL-F}	260°C for 10 sec
Input Diode	
I _F	50 mA
V _R	6.0 V
P _D	100 mW
Output Transistor	
V _{CEO}	30.0 V
V _{ECO}	4.5 V
I _C	20 mA
P _D	150 mW

Transmissive Opto Sensors

Slotted Switch Wide Gap (Analog – Low Resolution)

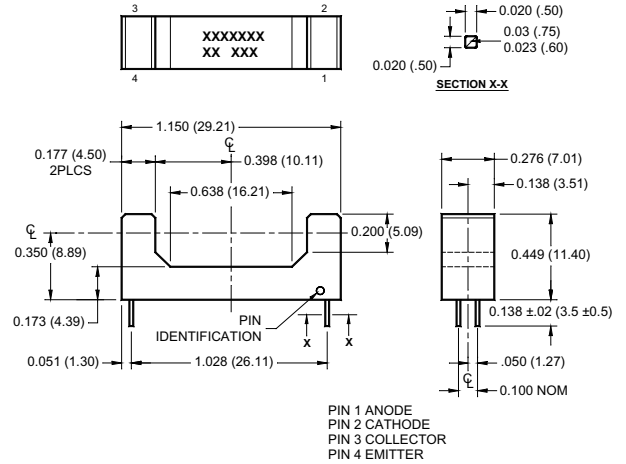
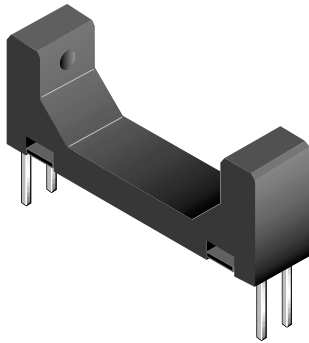

Part Number	Test Conditions		I_C (ON) (mA) min	BV_{CEO} (V) min	Output	Aperture Width (mm)		Gap Width (mm)
	I_F (mA)	V_{CE} (V)				Emitter	Sensor	
QVL21653	20	5	0.10	30	Phototransistor	1.5	1.5	20.22
QVL25335	10	5	5.0	30	Photodarlington	1.5	1.5	20.22

All dimensions are in inches (millimeters)

Absolute Maximum Ratings	PARAMETER	QVL21653	QVL25335	
	Temperature			
	T_{OPR}	-40 to +85°C	-40 to +85°C	
	T_{STG}	-40 to +85°C	-40 to +85°C	
	T_{SOL-H}	240°C for 5 sec	240°C for 5 sec	
	T_{SOL-F}	260°C for 10 sec	260°C for 10 sec	
	Input Diode			
	I_F	50 mA	50 mA	
	V_R	6.0 V	6.0 V	
	P_D	100 mW	100 mW	
Output Transistor				
V_{CEO}	30.0 V	30.0 V		
V_{ECO}	4.5 V	6.0 V		
I_C	20 mA	40 mA		
P_D	150 mW	150 mW		

Transmissive Opto Sensors

Slotted Switch MOC (Analog – Standard Resolution)

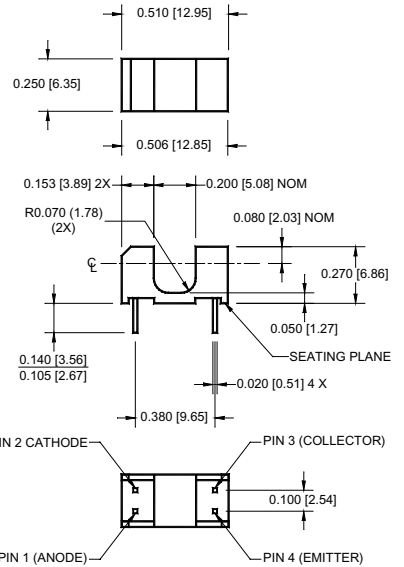
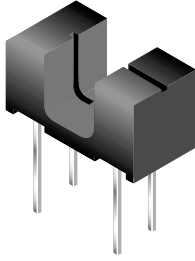

Part Number	Test Conditions		I_C (ON) (mA) min	BV_{CEO} (V) min	Output	Aperture Width (mm)		Gap Width (mm)
	I_F (mA)	V_{CE} (V)				Emitter	Sensor	
MOC70P1	20	10	1.0	30	Phototransistor	1.0	1.0	5.08
MOC70P2	20	10	2.0	30	Phototransistor	1.0	1.0	5.08
MOC70P3	20	10	4.0	30	Phototransistor	1.0	1.0	5.08

All dimensions are in inches (millimeters)

Absolute Maximum Ratings

PARAMETER	MOC
Temperature	
T_{OPR}	-55 to +85°C
T_{STG}	-55 to +85°C
T_{SOL-I}	240°C for 5 sec
T_{SOL-F}	260°C for 10 sec
Input Diode	
I_F	60 mA
V_R	6.0 V
P_D	150 mW
Output Transistor	
V_{CEO}	30.0 V
V_{ECO}	4.5 V
I_C	20 mA
P_D	150 mW

Transmissive Opto Sensors

Slotted Switch 8 mm Gap (Analog – High Resolution)

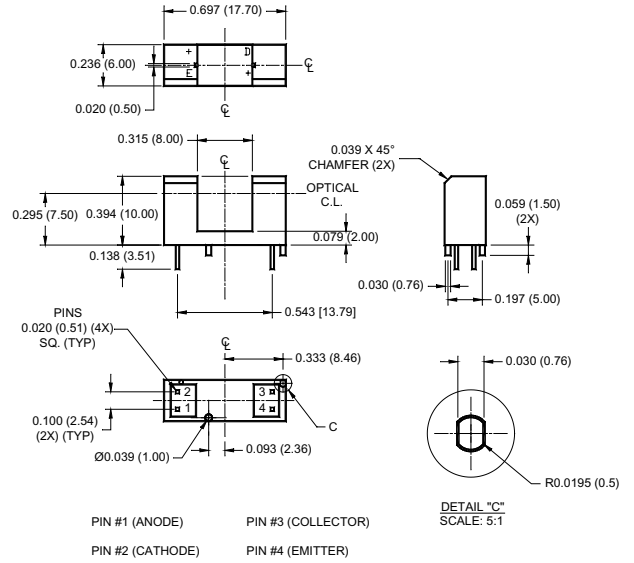
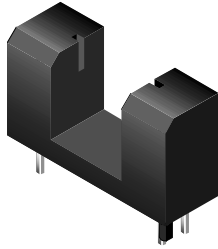

Part Number	Test Conditions		I_C (ON) (mA) min	BV_{CEO} (V) min	Output	Aperture Width (mm)		Gap Width (mm)
	I_F (mA)	V_{CE} (V)				Emitter	Sensor	
QVE00034	20	10	0.50	30	Phototransistor	0.50	0.50	8.00

All dimensions are in inches (millimeters)

Absolute Maximum Ratings	PARAMETER	QVE	
	Temperature		
	T_{OPR}	-55 to +100°C	
	T_{STG}	-55 to +100°C	
	T_{SOL-H}	240°C for 5 sec	
	T_{SOL-F}	260°C for 10 sec	
	Input Diode		
	I_F	50 mA	
	V_R	6.0 V	
	P_D	100 mW	
	Output Transistor		
	V_{CEO}	30.0 V	
	V_{ECO}	4.5 V	
	I_C	20 mA	
P_D	150 mW		

Transmissive Opto Sensors

Surface Mount Opto Interrupter QCK (Analog – Low Resolution)

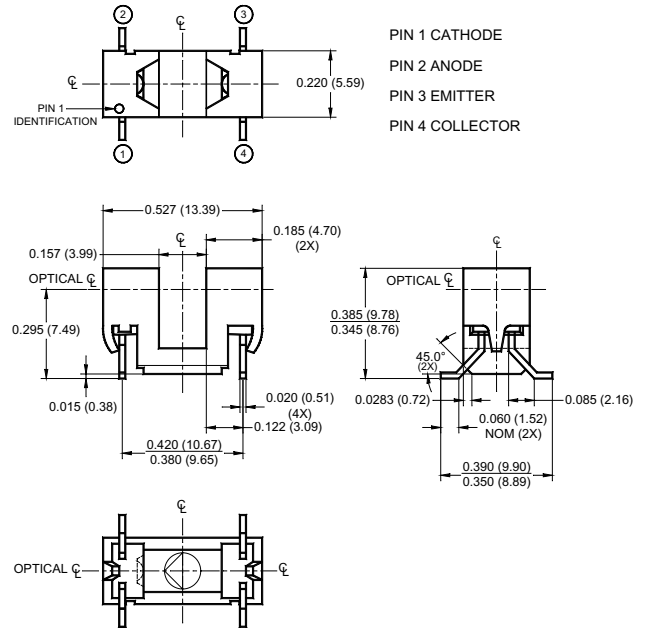
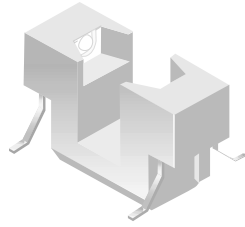

Part Number	Test Conditions		I_C (ON) (mA) min	BV_{CEO} (V) min	Output	Aperture Width (mm)		Gap Width (mm)
	I_F (mA)	V_{CE} (V)				Emitter	Sensor	
QCK3	5	1.5	1.0	30	Photodarlington	NA	NA	3.99
QCK4	5	1.5	10.0	30	Photodarlington	NA	NA	3.99
QCK5	20	5	2.00	30	Phototransistor	NA	NA	3.99

All dimensions are in inches (millimeters)

Absolute Maximum Ratings	PARAMETER	QCK3, 4	QCK5	
	Temperature			
	T_{OPR}	-40 to +100°C	-40 to +100°C	
	T_{STG}	-40 to +100°C	-40 to +100°C	
	T_{SOLH}	183°C for 60 sec (pre-heating stage)	183°C for 60 sec (pre-heating stage)	
	T_{SOLF}	230°C for 5 sec (reflow stage)	230°C for 5 sec (reflow stage)	
	Input Diode			
	I_F	50 mA	5 mA	
	V_R	6.0 V	6.0 V	
	P_D	100 mW	100 mW	
	Output Transistor			
	V_{CEO}	30.0 V	30.0 V	
V_{ECO}	6.0 V	6.0 V		
I_C	40 mA	20 mA		
P_D	150 mW	150 mW		

Transmissive Opto Sensors

Surface Mount Switch 2 mm Gap (Analog – High Resolution)

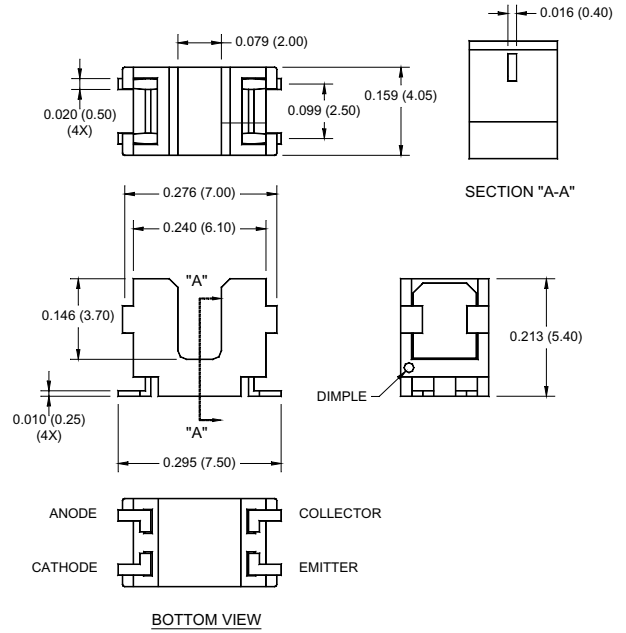
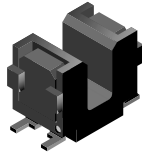

Part Number	Test Conditions		I_C (ON) (mA) min	BV_{CEO} (V) min	Output	Aperture Width (mm)		Gap Width (mm)
	I_F (mA)	V_{CE} (V)				Emitter	Sensor	
QVE00033	5	5	0.10	30	Phototransistor	0.4	0.4	2.00

All dimensions are in inches (millimeters)

Absolute Maximum Ratings	PARAMETER	QVE	
	Temperature		
	T_{OPR}	-55 to +100°C	
	T_{STG}	-55 to +100°C	
	T_{SOLH}	160°C for 120 sec (pre-heating stage)	
	T_{SOLF}	200°C for 60 sec (reflow stage)	
	Input Diode		
	I_F	50 mA	
	V_R	6.0 V	
	P_D	75 mW	
	Output Transistor		
	V_{CEO}	300 V	
	V_{ECO}	4.5 V	
I_C	20 mA		
P_D	75 mW		

Transmissive Opto Sensors

Slotted Switch Horizontal with Wires (Analog – High Resolution)

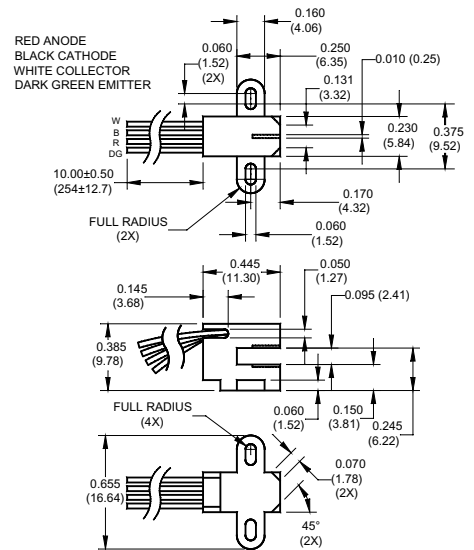
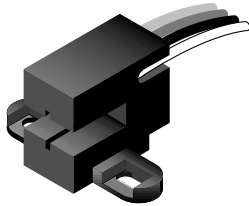

All dimensions are in inches (millimeters)

Part Number	Test Conditions		I_C (ON) (mA) min	BV_{CEO} (V) min	Output	Aperture Width (mm)		Gap Width (mm)
	I_F (mA)	V_{CE} (V)				Emitter	Sensor	
QVE00039	20	10	0.50	30	Phototransistor	0.25	0.25	2.41

Slotted Switch Logic with Wires (OPTOLOGIC® – High Resolution)

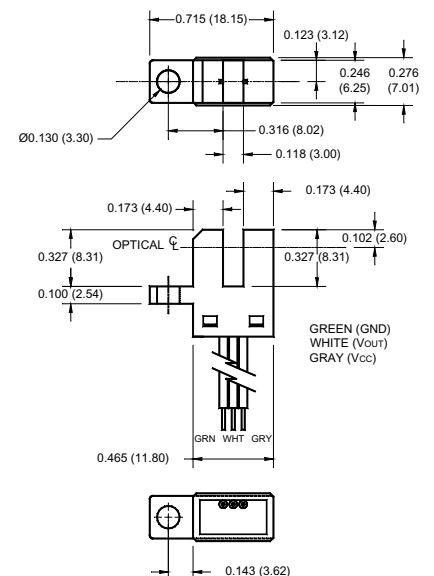
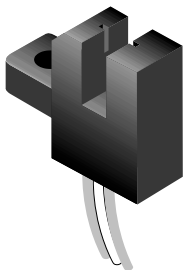

All dimensions are in inches (millimeters)

Part Number	Test Conditions V_{CC} (V)	I_{CC} (mA) max	Output	Aperture Width (mm)		Gap Width (mm)
				Emitter	Sensor	
QVE00112	5	20.0	Inverter Open Collector	0.35	0.35	4.40

Absolute Maximum Ratings	PARAMETER QVE00039	
	Temperature	
	T_{OPR}	-40 to +85°C
	T_{STG}	-40 to +85°C
	Input Diode	
	I_F	50 mA
	V_R	6.0 V
	P_D	100 mW
	Output Transistor	
	V_{CEO}	30.0 V
	V_{ECO}	4.5 V
	I_C	20 mA
P_D	150 mW	

Absolute Maximum Ratings	PARAMETER QVE00112	
	Temperature	
	T_{OPR}	-40 to +85°C
	T_{STG}	-40 to +85°C
	Input Diode	
	I_F	NA
	V_R	NA
	P_D	NA
	Output Optologic®	
	I_O	50 mA
	V_{CC}	4.5 – 16 V
	V_O	30 V
P_D	150 mW	

Reflective Opto Sensors

Reflective Arrowhead with Dust Cover (Focused)

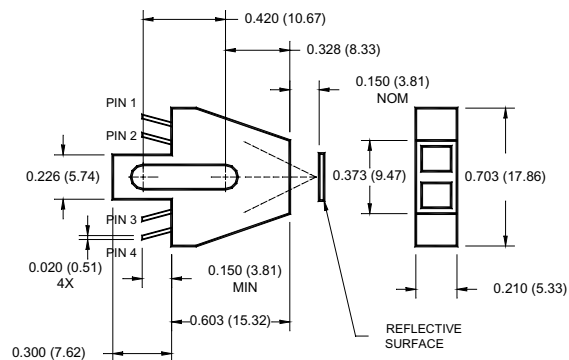
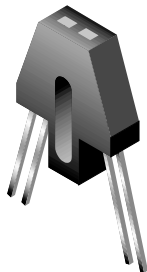

PIN1 ANODE
PIN2 CATHODE
PIN3 COLLECTOR
PIN4 EMITTER

All dimensions are in inches (millimeters)

Part Number	Test Conditions		Sensor to Surface Distance (inch)	I_C (ON) (mA) min	BV_{CEO} (V) min	Output	Wavelength λ_p (nm)
	I_F (mA)	V_{CE} (V)					
QRB1113	40	5	0.150	0.20	30	Phototransistor	940
QRB1114	40	5	0.150	0.60	30	Phototransistor	940

Reflective Arrowhead without Dust Cover (Focused)

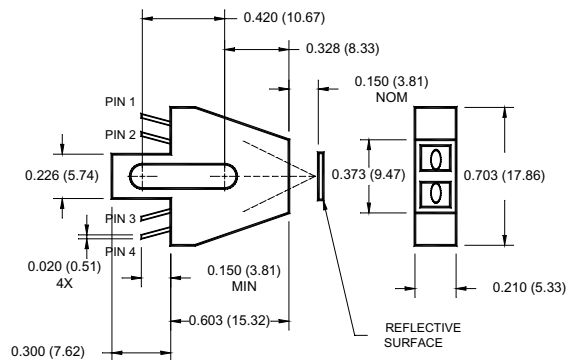
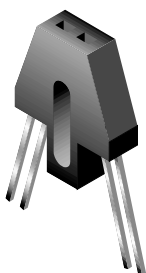

PIN1 ANODE
PIN2 CATHODE
PIN3 COLLECTOR
PIN4 EMITTER

All dimensions are in inches (millimeters)

Part Number	Test Conditions		Sensor to Surface Distance (inch)	I_C (ON) (mA) min	BV_{CEO} (V) min	Output	Wavelength λ_p (nm)
	I_F (mA)	V_{CE} (V)					
QRC1113	40	5	0.150	0.20	30	Phototransistor	940

Absolute Maximum Ratings	PARAMETER	QRB, QRC	
	Temperature		
	T_{OPR}	-40 to +85°C	
	T_{STG}	-40 to +85°C	
	T_{SOL-I}	240°C for 5 sec	
	T_{SOL-F}	260°C for 10 sec	
	Input Diode		
	I_F	50 mA	
	V_R	5.0 V	
	P_D	100 mW	
Output Transistor			
V_{CEO}	30.0 V		
V_{ECO}	4.5 V		
I_C	20 mA		
P_D	100 mW		

Reflective Opto Sensors

Reflective Focusing Sensor PCB Mount

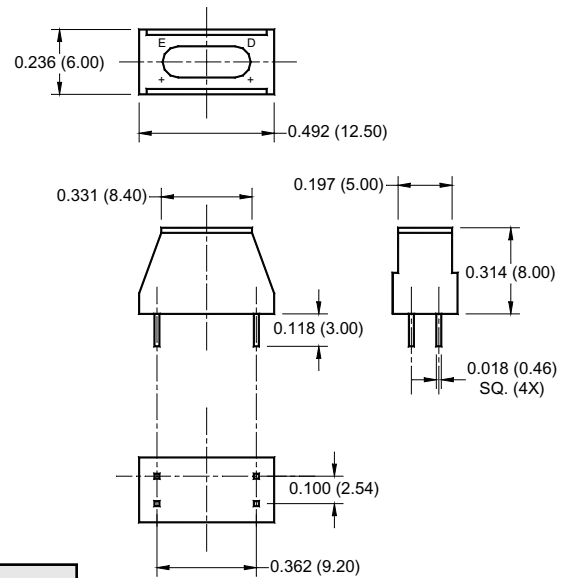
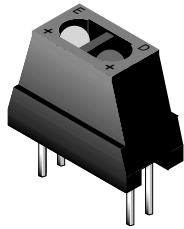

All dimensions are in inches (millimeters)

Part Number	Test Conditions			I_C (ON) (mA) min	BV_{CEO} (V) min	Output	Wavelength λ_p (nm)
	I_f (mA)	V_{CE} (V)	Sensor to Surface Distance (inch)				
QRE00034	20	10	0.160	0.16	30	Phototransistor	940

Reflective Non-focusing Sensor PCB Mount

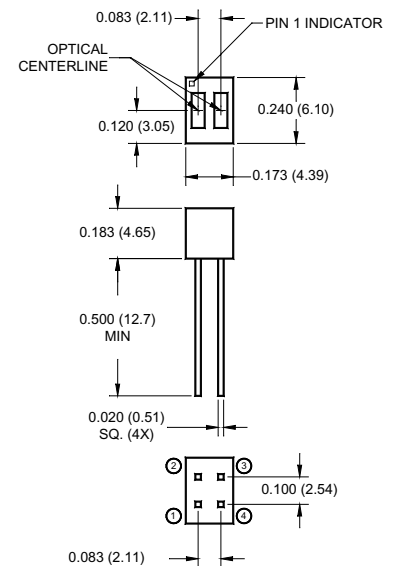
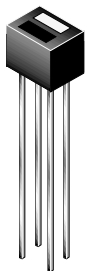

PIN 1 COLLECTOR PIN 3 ANODE
PIN 2 EMITTER PIN 4 CATHODE

All dimensions are in inches (millimeters)

Part Number	Test Conditions			I_C (ON) (mA) min	BV_{CEO} (V) min	Output	Wavelength λ_p (nm)
	I_f (mA)	V_{CE} (V)	Sensor to Surface Distance (inch)				
QRD11113	20	5	0.050	0.30	30	Phototransistor	880
QRD11114	20	5	0.050	1.00	30	Phototransistor	880
QRD1313	20	5	0.050	10	15	Photodarlington	880

Reflective Opto Sensors

Reflective Surface Mount (Unfocused)

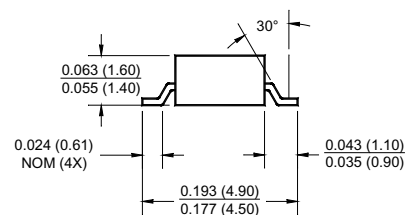
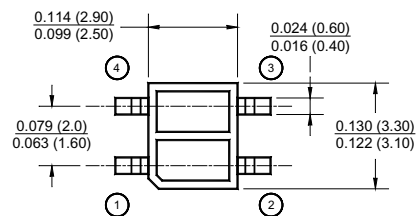
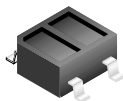

PIN 1 ANODE PIN 3 COLLECTOR
 PIN 2 CATHODE PIN 4 EMITTER

All dimensions are in inches (millimeters)

Part Number	Test Conditions		Sensor to Surface Distance (inch)	I _{C (ON)} (mA) min	BV _{CEO} (V) min	Output	Wavelength λ _p (nm)
	I _f (mA)	V _{CE} (V)					
QRE1113GR	20	5	0.040	0.15	30	Phototransistor	940

Absolute Maximum Ratings	PARAMETER	QRD1113, 4	QRD1313	QRE1113GR	QRE00034	
	Temperature					
	T _{OPR}	-40 to +85°C	-40 to +85°C	-25 to +85°C	-40 to +85°C	
	T _{STG}	-40 to +85°C	-40 to +85°C	-30 to +100°C	-40 to +85°C	
	T _{SOL-H}	240°C for 5 sec	240°C for 5 sec	240°C for 5 sec	240°C for 5 sec	
	T _{SOL-F}	260°C for 10 sec	260°C for 10 sec	260°C for 10 sec	260°C for 10 sec	
	Input Diode					
	I _f	50 mA	50 mA	50 mA	50 mA	
	V _R	6.0 V	6.0 V	6.0 V	6.0 V	
	P _D	100 mW	100 mW	75 mW	100 mW	
Output Transistor						
V _{CEO}	30.0 V	15.0 V	30.0 V	30.0 V		
V _{ECC}	4.5 V	6.0 V	5.0 V	6.0 V		
I _C	20 mA	40 mA	20 mA	20 mA		
P _D	100 mW	100 mW	50 mW	100 mW		

Reflective Opto Sensors

Reflective Arrowhead with Dust Cover, Wires (Focused)

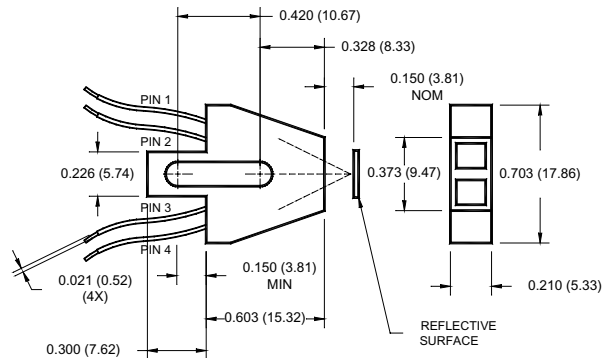
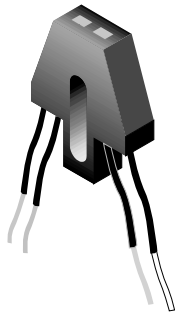

PIN1 ANODE
PIN2 CATHODE
PIN3 COLLECTOR
PIN4 EMITTER

All dimensions are in inches (millimeters)

Part Number	Test Conditions		Sensor to Surface Distance (inch)	I_C (ON) (mA) min	BV_{CEO} (V) min	Output	Wavelength λ_p (nm)
	I_F (mA)	V_{CE} (V)					
QRB1133	40	5	0.150	0.20	30	Phototransistor	940
QRB1134	40	5	0.150	0.60	30	Phototransistor	940

Reflective Arrowhead without Dust Cover, Wires (Focused)

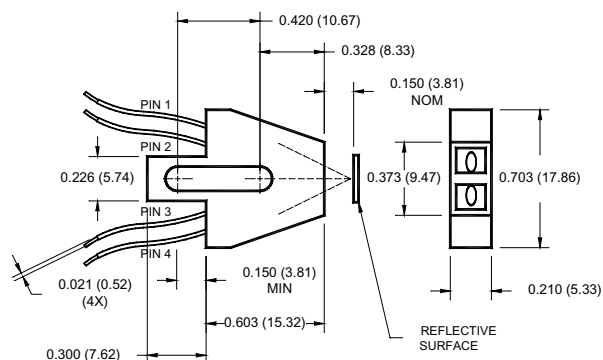
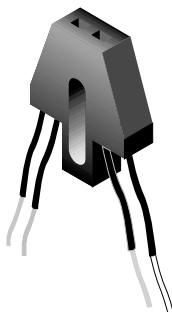

PIN1 ANODE
PIN2 CATHODE
PIN3 COLLECTOR
PIN4 EMITTER

All dimensions are in inches (millimeters)

Part Number	Test Conditions		Sensor to Surface Distance (inch)	I_C (ON) (mA) min	BV_{CEO} (V) min	Output	Wavelength λ_p (nm)
	I_F (mA)	V_{CE} (V)					
QRC1133	40	5	0.150	0.20	30	Phototransistor	940

Absolute Maximum Ratings	PARAMETER	QRB, QRC	
	Temperature		
	T_{OPR}	-40 to +85°C	
	T_{STG}	-40 to +85°C	
	Input Diode		
	I_F	50 mA	
	V_R	5.0 V	
	P_D	100 mW	
	Output Transistor		
	V_{CEO}	30.0 V	
	V_{ECO}	4.5 V	
	I_C	20 mA	
P_D	100 mW		

Ordering Information

Package Description ¹ (Alphanumeric)	Packaging Options			
	Bag (Quantity)	Tube (Quantity)	Tape on Ammopack	Tape on Reel
PLCC-2 Detector	1000			■
PLCC-2 Diode	1000			■
Reflective Arrowhead with Dust Cover	50			
Reflective Arrowhead with Dust Cover, Wires	20			
Reflective Arrowhead without Dust Cover	50			
Reflective Arrowhead without Dust Cover, Wires	20			
Reflective Focusing Sensor PCB Mount		50		
Reflective Non-focusing Sensor PCB Mount	100			
Reflective Surface Mount Package				■
Sidelooker Detector	500			■
Sidelooker Detector (No Lens)	1000			■
Sidelooker Diode	500			■
Sidelooker OPTOLOGIC®	500			■
Slotted Switch 5 mm Gap, 9 mm Lead Spacing		50		
Slotted Switch 5 mm Gap, 10 mm Lead Spacing		50		
Slotted Switch 8 mm Gap		50		
Slotted Switch H21		50		
Slotted Switch H22		50		
Slotted Switch High Profile		50		
Slotted Switch Horizontal with Wires	50			
Slotted Switch Logic 5 mm		50		
Slotted Switch Logic H21		50		
Slotted Switch Logic H22		50		
Slotted Switch Logic with Wires	50			
Slotted Switch MOC		50		
Slotted Switch QVA		50		
Slotted Switch QVB		50		
Slotted Switch Wide Gap		50		
Surface Mount Opto Interrupter QCK		25		■
Surface Mount Switch 2 mm Gap				■
Thin Sidelooker Detector	500			■
Thin Sidelooker Diode	500			■
T- ³ / ₄ (2 mm) Detector	1000			■
T- ³ / ₄ (2 mm) Diode	1000			■
T-1 (3 mm) Detector	250		■	■
T-1 (3 mm) Diode	250		■	■
T-1 ³ / ₄ (5 mm) Detector	250		■	■
T-1 ³ / ₄ (5 mm) Diode	250		■	■
TO-18 Detector (Convex Lens)	500			
TO-18 Detector (Flat Lens)	500			
TO-18 Detector (Plastic)	250		■	■
TO-18 OPTOLOGIC®	500			
TO-46 Package (Convex Lens)	500			
TO-46 Package (Flat Lens)	500			
TO-46 (Plastic) Diode	250		■	■
TO-92 Detector Package	1000			■

¹ Package descriptions match the titles of packages on the tables of specifications pages.

Infrared Glossary of Terms

Terms	Definitions	Symbol	Unit
Breakdown Voltage	Collector to base breakdown voltage with the emitter open.	BV_{CBO}	V
	Collector to emitter breakdown voltage with the base open.	BV_{CEO}	V
	Emitter to collector breakdown voltage with the base open.	BV_{ECO}	V
Collector-Emitter Leakage	Collector to emitter current with base open and without radiant incidence.	I_{CEO}	nA
Collector-Emitter Voltage	Collector to emitter voltage with base open.	V_{CEO}	V
Collector Current	Collector current.	I_C	mA
Dark Current	Reverse dark current at a given reverse voltage.	I_{RD}	nA
Emitter-Collector Voltage	Emitter to collector voltage with base open.	V_{ECO}	V
Forward Voltage	Voltage between anode and cathode at a specified forward current.	V_F	V
Forward Current	The current flowing through a diode from anode to cathode.	I_F	mA
Light Current	Current flowing through a device due to radiant incidence.	I_L	mA
On-State Collector Current	Current flowing from collector due to radiant incidence.	$I_{C(ON)}$	mA
Operating Temperature Range	Temperature range for which operating specifications are valid.	T_{OPR}	°C
Output Current	Output current.	I_O	mA
	Logic high output voltage.	V_{OH}	V
	Logic low output voltage.	V_{OL}	V
Power Dissipation	Power dissipation.	P_D	mW
Radiant Intensity	The radiant flux generated per unit solid angle on the axis.	I_E	mW/sr
Reception Angle	The angle of the cone where the sensitivity is half of that on the optical axis.	$2 \theta_{1/2}$	°
Reverse Current	Current flowing through a diode from cathode and anode.	I_R	µA
Reverse Voltage	Voltage between cathode and anode at a specified reverse current.	V_F	V
Saturation Voltage	Collector to emitter saturation voltage.	$V_{CE SAT}$	V
Soldering Temperature	Temperature for lead soldering.	T_{SOL}	°C
	Temperature for lead soldering with iron.	T_{SOL-I}	°C
	Temperature for wave soldering.	T_{SOL-F}	°C
Storage Temperature Range	Temperature range for storage while not in operation.	T_{STR}	°C
Supply Current	Current drawn from the supply at a given voltage.	I_{CC}	mA
Supply Voltage	Operating supply voltage.	V_{CC}	V
Threshold	Amount of incident light required to turn a device on.	$E_{\theta+}$	mW/cm ²
	Amount of incident light required to turn a device off.	$E_{\theta-}$	mW/cm ²
	Forward current required to turn a device on.	I_{F+}	mA
	Forward current required to turn a device off.	I_{F-}	mA
Total Output Power	The total optical output power.	P_O	mW
Viewing Angle	The angle of the cone where the luminous intensity is half of that on the optical axis.	$2 \theta_{1/2}$	°

Frequently Asked Questions

What is the greatest distance at which an infrared solution will still work?

There is no absolute answer to this question, rather it depends on the application. In most cases, by pulsing the emitter with a high drive current and using a sensitive photosensor, such as a photodarlington, one can expand the range.

- The range for detecting an object by reflection can be from less than 1 mm up to 400 mm. The factors involved are the configuration and reflectivity of the reflective surface, the drive current of the emitter, and the photosensor output. Dust, however, can impair the reflectivity and decrease the range.
- Object sensing by transmissivity (ie. breaking a beam of light between two points with an object) has a range from less than 1 mm up to 12 m. The determining factors are the size of the object used to break the beam, the drive current of the emitter, the output type of the photosensor, and the electrical timing techniques used, such as synchronous detection.
- For pure data transmission, the range is from less than 1 mm up to 15 m. The determining factors are the data rate, the coding and modulation technique, and the expected signal to noise ratio or bit error rate. A high emitter drive current can increase the range of the system.

Can IR photosensors detect visible light?

Yes. All of the Fairchild photosensors are constructed using silicon chips. Silicon has a relatively flat sensitivity range and can detect the entire visible spectrum.

The sensitivity, however, decreases from red wavelengths (660 nm) to blue wavelengths (450 nm). Most Fairchild photosensors, however, are sold with a daylight filter on the lens which blocks most visible light from reaching the sensing area of the chip. Depending on the need a customer can usually purchase photosensors without the daylight filter. Curves are available showing the output response of the photosensor with and without a daylight filter.

Can ambient light cause photosensors to false trigger?

The photosensors, as discussed above, are typically built with a daylight filter that prevents most visible light in the environment from reaching the detector chip. Curves are available showing the output response with and without a daylight filter. The response to light sources like fluorescent tubes, phosphorescent sources, or other artificial light sources depends on their spectral characteristics and may be noticeable.

What is the most efficient emitter?

The brightest emitter we offer, in terms of on-axis intensity, is the QED123.

This emitter has a narrow emission angle. If a wider emission angle is preferred, the QED223 or QED234 are recommended.

What is the response time of emitters and photosensors?

Each component type has a different response time, which is specified as rise time or fall time. The typical rise times for each product family are given below.

- 940 nm emitters: 1 μ s
- 880 nm emitters: 0.8 μ s
- Phototransistors: 10 μ s
- Photodarlingtons: 100 μ s
- Photodiodes: 0.01 – 0.05 μ s
- OPTOLOGIC® Photosensors: 0.1 μ s

What is the maximum driving current of emitters?

The answer to this question depends on the type of emitter and the forward current conditions. Driving conditions can be either continuous or pulsed. The continuous maximum current is specified in the data sheet of the product. The maximum pulsed current depends on the pulse width and the duty cycle. The duty cycle is determined by dividing the pulse width by the period of the pulse. The pulsed current can range as high as two amps (2 A) if the pulses are very short and the duty cycle is very low.

Index

Part Number	Page	Part Number	Page	Part Number	Page
1N6264	5	L14G1	14	QRD1313	33
1N6265	6	L14G2	14	QRE00034	33
BPW36	14	L14G3	14	QRE1113GR	34
BPW37	14	L14N1	15	QSA156	16
BPW38	14	L14N2	15	QSA157	16
CNY28	17	L14P1	14	QSA158	16
CNY29	17	L14P2	14	QSA159	16
CNY36	19	LED55B	5	QSB320	13
CQX14	5	LED55BF	6	QSB363	13
CQX15	6	LED55C	5	QSC112	7
CQX16	5	LED55CF	6	QSC113	7
CQX17	6	LED56	5	QSC114	7
F5D1	5	LED56F	6	QSC133	7
F5D2	5	MOC70P1	27	QSD122	7
F5D3	5	MOC70P2	27	QSD123	7
F5E1	6	MOC70P3	27	QSD124	7
F5E2	6	QCK3	29	QSD722	8
F5E3	6	QCK4	29	QSD723	8
H21A1	17	QCK5	29	QSD724	8
H21A2	17	QEB363	4	QSD733	8
H21A3	17	QEB373	4	QSD2030	11
H21A4	17	QEB421	4	QSE113	9
H21A5	17	QEB441	4	QSE114	9
H21A6	17	QEC112	1	QSE122	9
H21B1	17	QEC113	1	QSE133	9
H21B2	17	QEC121	1	QSE156	12
H21B3	17	QEC122	1	QSE157	12
H21B4	17	QEC123	1	QSE158	12
H21B5	17	QED121	1	QSE159	12
H21B6	17	QED122	1	QSE213	9
H21LOB	18	QED123	1	QSE214	9
H21LOI	18	QED221	1	QSE773	10
H21LTB	18	QED222	1	QSE973	10
H21LTI	18	QED223	1	QVA11134	21
H22A1	19	QED233	1	QVA21114	21
H22A2	19	QED234	1	QVB11134	22
H22A3	19	QED422	2	QVB21114	22
H22A4	19	QED423	2	QVE00033	30
H22A5	19	QED522	2	QVE00034	28
H22A6	19	QED523	2	QVE00039	31
H22B1	19	QED633	1	QVE00112	31
H22B2	19	QED634	1	QVE00118	23
H22B3	19	QEE113	3	QVE00120	24
H22B4	19	QEE122	3	QVE00832	23
H22B5	19	QEE123	3	QVE11233	25
H22B6	19	QEE213	3	QVL21653	26
H22LOB	20	QRB1113	32	QVL25335	26
H22LOI	20	QRB1114	32		
H22LTB	20	QRB1133	35		
H22LTI	20	QRB1134	35		
L14C1	15	QRC1113	32		
L14C2	15	QRC1133	35		
L14F1	14	QRD1113	33		
L14F2	14	QRD1114	33		

www.fairchildsemi.com/infrared

Americas

Fairchild Semiconductor
Customer Response Center
7701 Las Colinas Ridge, Suite 400
Irving, Texas 75063
United States
Tel: 888-522-5372
Fax: 972-910-8036

China

Fairchild Semiconductor
Hong Kong Ltd.
Shenzhen Representative Office
Room 3107-B, Shun Hing Square
Di Wang Commercial Centre
5002 Shen Nan Road East
Shenzhen PRC 518008
Tel: 86-755-246-3008
Fax: 86-755-246-2092

Fairchild Semiconductor
(Shanghai) Company Limited
Puxi Liaison Office
Room 2208, Kerry Centre
No. 1515 Nanjing West Road
Jingan, Shanghai 200040
P.R. China
Tel: 86-21-5298-6262
Fax: 86-21-5298-5118/9

Finland

Fairchild Semiconductor
Itakatu 3D213
FIN-00930 Helsinki
Tel: 358-9-3411266
Fax: 358-9-3411292

France

Fairchild Semiconductor SAS
Immeuble Dublin
2, place Gustave Eiffel
Silic 227
F-94528 Rungis Cedex
Tel: 33 (0) 1 56 34 72 10
Fax: 33 (0) 1 56 34 72 11

Germany

Fairchild Semiconductor
Oskar-von-Miller-Strasse 4e
D-82256 Fuerstenfeldbruck
Tel: 49-8141-6102 0
Fax: 49-8141-6102 100

Hong Kong

Fairchild Semiconductor
Hong Kong Ltd.
19/F, CMG Asia Tower
The Gateway II, 15 Canton Road
Tsimshatsui, Kowloon
Hong Kong
Tel: 852-2722-8338
Fax: 852-2722-8383

Italy

Fairchild Semiconductor Srl
Via Carducci 125
Sesto San Giovanni, Milan I-20099
Tel: 39-02-2491111
Fax: 39-02-26263424

Japan

Fairchild Semiconductor Japan, Ltd.
6F, Bancho-Kaikan
12-1 Gobancho, Chiyoda-ku
Tokyo, 102-0076
Tel: 81-3-5275-8380
Fax: 81-3-5275-8390

Fairchild Semiconductor, Ltd.
Osaka Office
8F Shin-Osaka-Meiko Building
4-3-12, Miyahara Yodogawa-ku
Osaka-shi, 532-0003
Tel: 81-6-398-3670
Fax: 81-6-398-3680

Korea

Fairchild Korea Semiconductor, Ltd.
Buchon Office
82-3, Dodang-Dong
Wonmi-ku, Buchon
Kyounggi-Do
Tel: 82-32-680-1000
Fax: 82-32-680-1949

Fairchild Korea Semiconductor, Ltd.
Suwon Office
6th Floor Song-i-Building
976-12, Youngtong-dong
Paldal-ku, Suwon
Gyunggi-do 442-470
Tel: 82-31-205-0291
Fax: 82-31-205-3352

Korea (Continued)

Fairchild Korea Semiconductor, Ltd.
Kumi Office
4FL, Seronet Building
274-9, Song Jung-Dong
Kumi, Kyungbuk 730-090
Tel: 82-54-457-4111
Fax: 82-54-457-4121

Mexico

Fairchild Semiconductor
Av. Vallarta #6503 Flr. 14
Col. Cd Granjas
Zapopan Jalisco 45010
Tel: 52-3-1100017
Fax: 52-3-1101878

Singapore

Fairchild Semiconductor
Asia Pacific Pte. Ltd.
350 Orchard Road
#20-01/03 Shaw House
238868 Vejile
Tel: 65-6836-0936
Fax: 65-6838-0321

Sweden

Fairchild Semiconductor
Industrivagen 7
SE-171 48 Solna
Tel: 46-8-6515530
Fax: 46-8-6515505

Taiwan

Fairchild Semiconductor
Hong Kong, Ltd.
Taiwan Branch
18th Floor, No. 167
Tun Hwa North Road
Taipei
Tel: 886-2-2712-0500
Fax: 886-2-2546-7188

UK

Fairchild Semiconductor Ltd.
Interface House
Interface Business Park
Wootton Bassett
Swindon
SN4 8QE
Tel: 44-1793-856856
Fax: 44-1793-856857



OPTOLOGIC® is a registered trademark of Fairchild Semiconductor.

Lit. No. 250002-001

© 2002 Fairchild Semiconductor Corporation, All Rights Reserved

