

Features

- High Voltage
- Industrial Standard Package
- Thick Al metal die and double stick bonding
- Thick copper baseplate
- UL E78996 approved
- 3500V_{RMS} isolating voltage

Benefits

- Up to 1600V
- Full compatible TO-240AA
- High Surge capability
- Easy Mounting on heatsink
- Al₂O₃ DBC insulator
- Heatsink grounded

75 A
95 A

Mechanical Description

The Generation V of Add-A-pak module combine the excellent thermal performance obtained by the usage of Direct Bonded Copper substrate with superior mechanical ruggedness, thanks to the insertion of a solid Copper baseplate at the bottom side of the device.

The Cu baseplate allow an easier mounting on the majority of heatsink with increased tolerance of surface roughness and improve thermal spread.

The Generation V of AAP module is manufactured without hard mold, eliminating in this way any possible direct stress on the leads.

The electrical terminals are secured against axial pull-out: they are fixed to the module housing via a click-stop feature already tested and proved as reliable on other IR modules.

Electrical Description

These modules are intended for general purpose high voltage applications such as high voltage regulated power supplies, lighting circuits, temperature and motor speed control circuits, UPS and battery charger.

Major Ratings and Characteristics

Parameters	IRKU/V71	IRKU/V91	Units	
$I_{T(AV)}$ @ 85°C	75	95	A	
$I_{T(RMS)}$	115	150	A	
I_{TSM}	@ 50Hz	1665	1785	A
	@ 60Hz	1740	1870	A
I^2t	@ 50Hz	13.86	15.91	KA ² s
	@ 60Hz	12.56	14.52	KA ² s
$I^2\sqrt{t}$	138.6	159.1	KA ² √s	
V_{RRM} range	400 to 1600		V	
T_{STG}	- 40 to 125		°C	
T_J	- 40 to 125		°C	



ELECTRICAL SPECIFICATIONS

Voltage Ratings

Type number	Voltage Code	V _{RRM} , maximum repetitive peak reverse voltage	V _{RSM} , maximum non-repetitive peak reverse voltage	V _{DRM} , max. repetitive peak off-state voltage, gate open circuit	I _{RRM} I _{DRM} 125°C mA
	-	V	V	V	
IRKU/V71, 91	04	400	500	400	15
	08	800	900	800	
	12	1200	1300	1200	
	16	1600	1700	1600	

On-state Conduction

Parameters	IRKU/V71	IRKU/V91	Units	Conditions
I _{T(AV)} Max. average on-state current	75	95	A	180° conduction, half sine wave, T _C = 85°C
I _{T(RMS)} Max. RMS on-state current	115	150		DC
	@T _C	80	75	°C
I _{TSM} Max. peak, one cycle non-repetitive on-state current	1665	1785	A	t=10ms No voltage reappplied
	1740	1870		t=8.3ms
	1400	1500		t=10ms 100% V _{RRM} reappplied
	1470	1570		t=8.3ms
	1850	2000		t=10ms T _J = 25°C,
	1940	2100		t=8.3ms no voltage reappplied
I ² t Max. I ² t for fusing	13.86	15.91	KA ² s	t=10ms No voltage reappplied
	12.56	14.52		t=8.3ms
	9.80	11.25		t=10ms 100% V _{RRM} reappplied
	8.96	10.27		t=8.3ms
	17.11	20.00		t=10ms T _J = 25°C,
	15.60	18.30		t=8.3ms no voltage reappplied
I ² vt Max. I ² vt for fusing (1)	138.6	159.1	KA ² vs	t=0.1 to 10ms, no voltage reappplied
V _{T(TO)} Max. value of threshold voltage (2)	0.82	0.80	V	Low level (3)
	0.85	0.85		High level (4)
r _t Max. value of on-state slope resistance (2)	3.00	2.40	mΩ	Low level (3)
	2.90	2.25		High level (4)
V _{TM} Max. peak on-state voltage	1.59	1.58	V	I _{TM} = π × I _{T(AV)}
				I _{FM} = π × I _{F(AV)}
di/dt Max. non-repetitive rate of rise of turned on current	150		A/μs	T _J = 25°C, from 0.67 V _{DRM} , I _{TM} = π × I _{T(AV)} , I _g = 500mA, t _r < 0.5 μs, t _p > 6 μs
I _H Max. holding current	200		mA	T _J = 25°C, anode supply = 6V, resistive load, gate open circuit
I _L Max. latching current	400			T _J = 25°C, anode supply = 6V, resistive load

(1) I²t for time t_x = I²vt × √t_x

(2) Average power = V_{T(TO)} × I_{T(AV)} + r_t × (I_{T(RMS)})²

(3) 16.7% × π × I_{AV} < I < π × I_{AV}

(4) I > π × I_{AV}

Triggering

Parameters	IRKU/V71	IRKU/V91	Units	Conditions	
P_{GM} Max. peak gate power	12	12	W		
$P_{G(AV)}$ Max. average gate power	3.0	3.0			
I_{GM} Max. peak gate current	3.0	3.0	A		
$-V_{GM}$ Max. peak negative gate voltage	10		V	Anode supply = 6V resistive load	
V_{GT} Max. gate voltage required to trigger	4.0				$T_J = -40^\circ\text{C}$
	2.5				$T_J = 25^\circ\text{C}$
	1.7		$T_J = 125^\circ\text{C}$		
I_{GT} Max. gate current required to trigger	270		mA	Anode supply = 6V resistive load	
	150				$T_J = -40^\circ\text{C}$
	80				$T_J = 25^\circ\text{C}$
V_{GD} Max. gate voltage that will not trigger	0.25		V	$T_J = 125^\circ\text{C}$, rated V_{DRM} applied	
I_{GD} Max. gate current that will not trigger	6		mA	$T_J = 125^\circ\text{C}$, rated V_{DRM} applied	

Blocking

Parameters	IRKU/V71, 91	Units	Conditions
I_{RRM} Max. peak reverse and off-state leakage current at V_{RRM} , V_{DRM}	15	mA	$T_J = 125^\circ\text{C}$, gate open circuit
V_{INS} RMS isolation voltage	2500 (1 min) 3500 (1 sec)	V	50 Hz, circuit to base, all terminals shorted
dv/dt Max. critical rate of rise of off-state voltage (5)	500	V/ μs	$T_J = 125^\circ\text{C}$, linear to $0.67 V_{DRM}$, gate open circuit

(5) Available with dv/dt = 1000V/ μs , to complete code add S90 i.e. IRKU91/16AS90.

Thermal and Mechanical Specifications

Parameters	IRK.71	IRK.91	Units	Conditions
T_J Junction operating temperature range	- 40 to 125		°C	
T_{stg} Storage temper. range	-40 to 125			
R_{thJC} Max. internal thermal resistance, junction to case	0.165	0.135	K/W	Per module, DC operation
R_{thCS} Typical thermal resistance case to heatsink	0.1			Mounting surface flat, smooth and greased
T Mounting torque $\pm 10\%$ to heatsink busbar	5		Nm	A mounting compound is recommended and the torque should be rechecked after a period of 3 hours to allow for the spread of the compound
	3			
wt Approximate weight	110 (4)		gr (oz)	
Case style	TO-240AA		JEDEC	

ΔR Conduction (per Junction)

(The following table shows the increment of thermal resistance R_{thJC} when devices operate at different conduction angles than DC)

Devices	Sine half wave conduction					Rect. wave conduction					Units
	180°	120°	90°	60°	30°	180°	120°	90°	60°	30°	
IRKU/V71	0.06	0.07	0.09	0.12	0.18	0.04	0.08	0.10	0.13	0.18	°C/W
IRKU/V91	0.04	0.05	0.06	0.08	0.12	0.03	0.05	0.06	0.08	0.12	

IRKU/71, 91 Series

Bulletin I27135 rev. F 10/02

International
IR Rectifier

Ordering Information Table

Device Code		IRK	U	91	/	16	A	S90
		(1)	(2)	(3)		(4)	(5)	(6)

1	-	Module type	
2	-	Circuit configuration (See Circuit Configuration table)	
3	-	Current code **	** Available with no auxiliary cathode.
4	-	Voltage code (See Voltage Ratings table)	To specify change: 91 to 92
5	-	A : Gen V	71 to 72
6	-	dv/dt code: S90 = dv/dt 1000 V/μs	e.g. : IRKU92/16A etc.
		No letter = dv/dt 500 Vμs	

IRK.92 types
With no auxiliary cathode

Outline Table

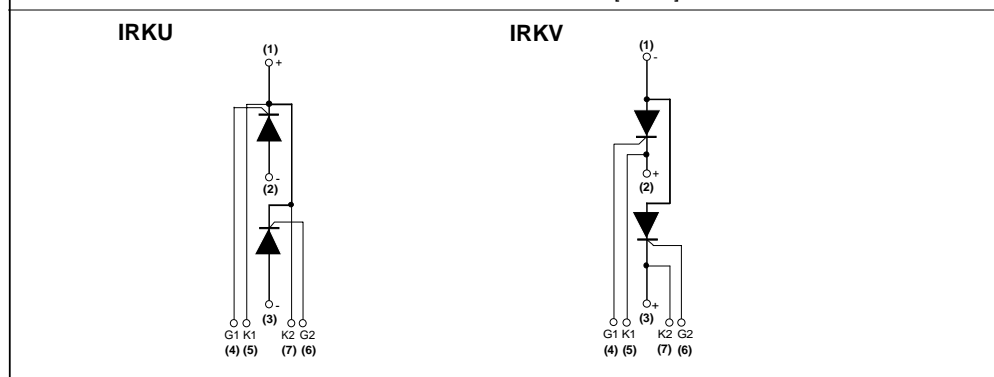
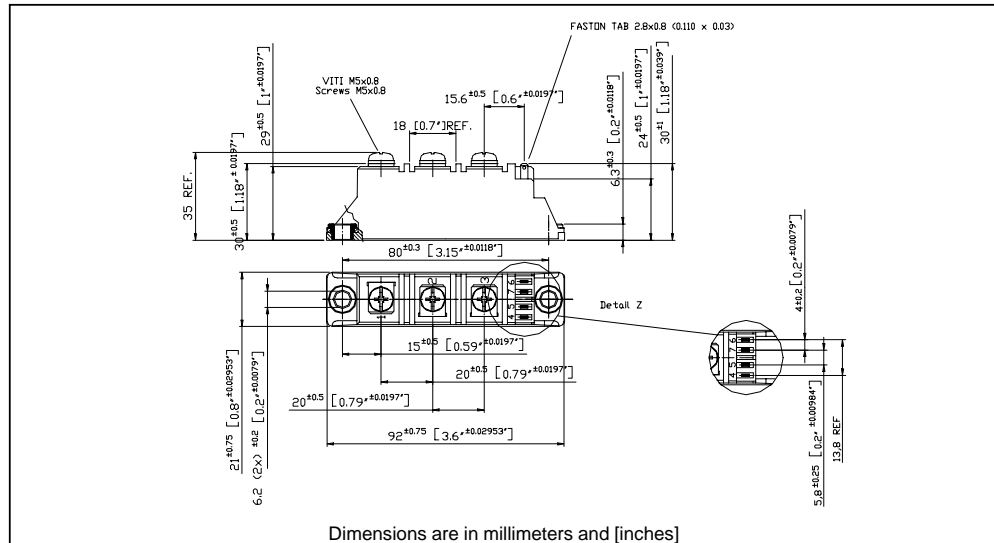

NOTE: To order the Optional Hardware see Bulletin I27900

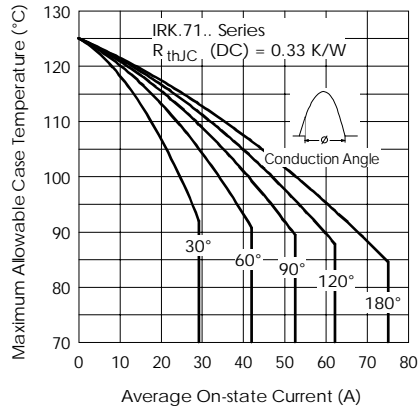

Fig. 1 - Current Ratings Characteristics

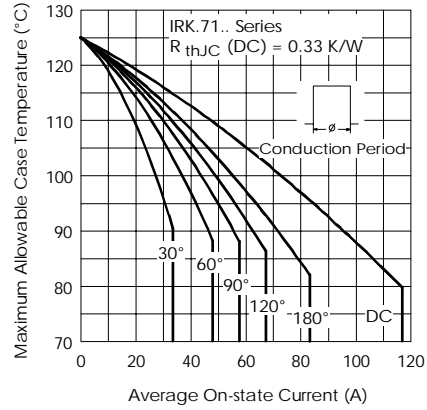

Fig. 2 - Current Ratings Characteristics

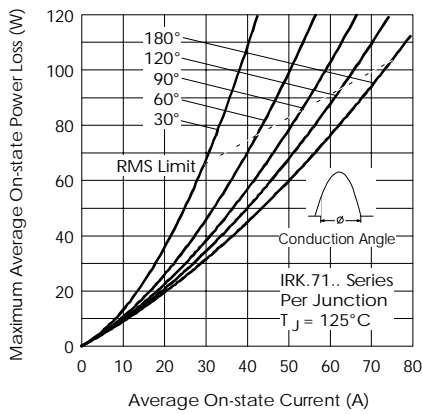

Fig. 3 - On-state Power Loss Characteristics

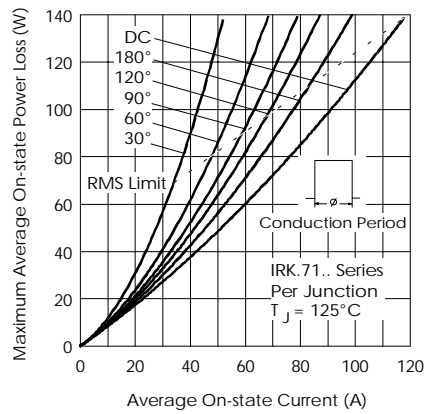

Fig. 4 - On-state Power Loss Characteristics

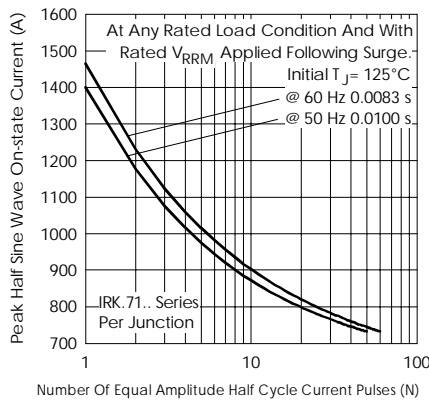

Fig. 5 - Maximum Non-Repetitive Surge Current

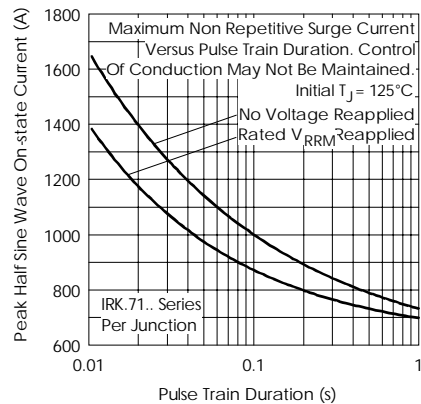

Fig. 6 - Maximum Non-Repetitive Surge Current

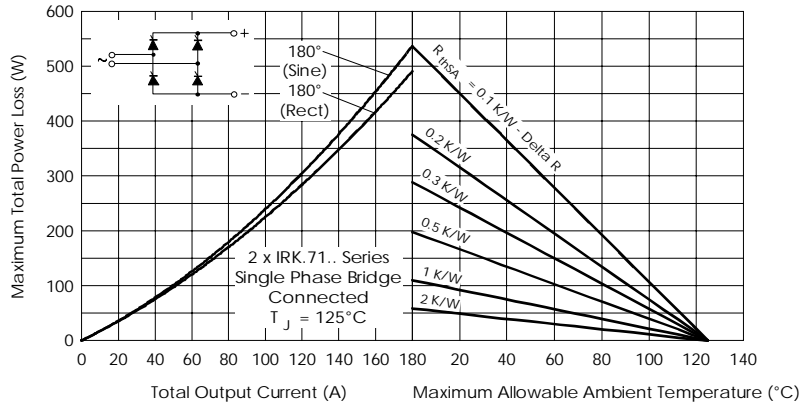

Fig. 7 - On-state Power Loss Characteristics (Single Phase Bridge IRKU+IRKV)

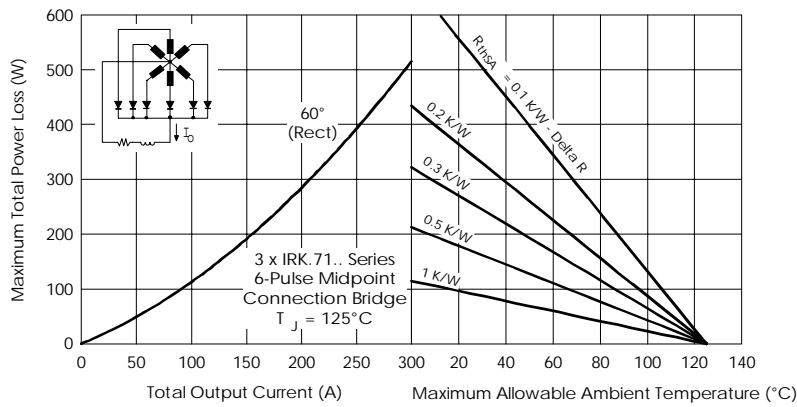

Fig. 8 - On-state Power Loss Characteristics

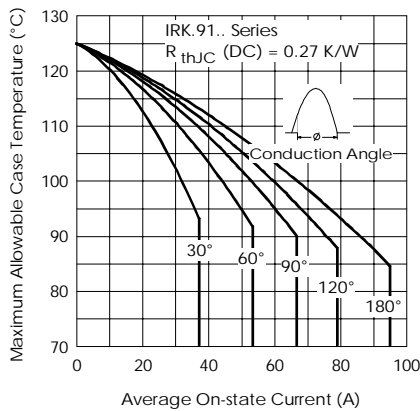

Fig. 9 - Current Ratings Characteristics

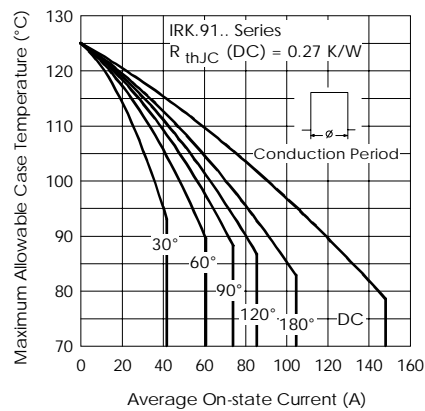

Fig. 10 - Current Ratings Characteristics

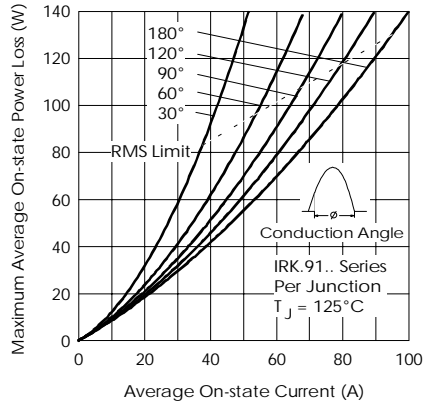

Fig. 11 - On-state Power Loss Characteristics

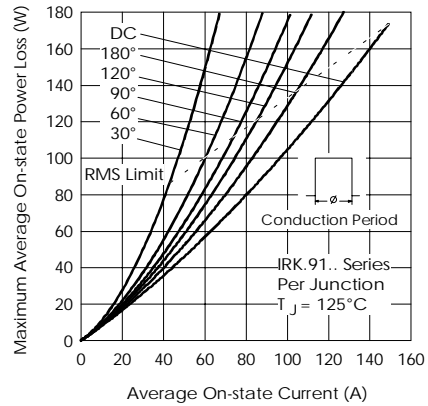

Fig. 12 - On-state Power Loss Characteristics

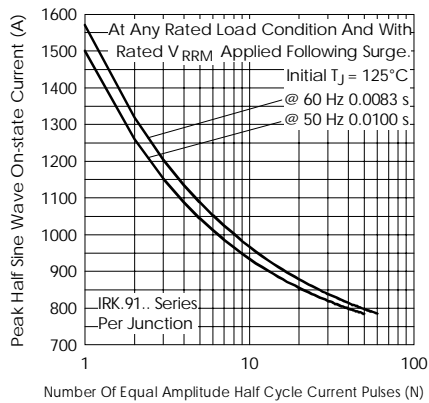

Fig. 13 - Maximum Non-Repetitive Surge Current

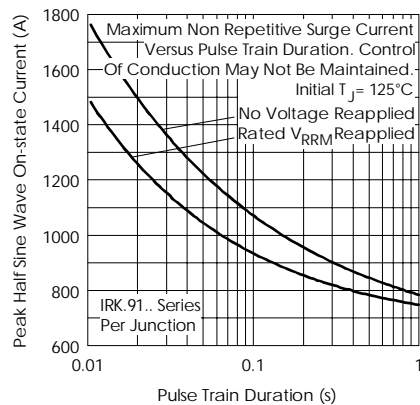

Fig. 14 - Maximum Non-Repetitive Surge Current

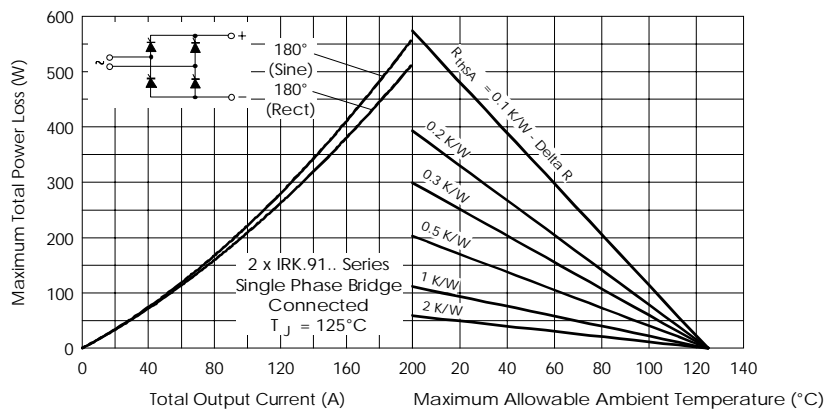

Fig. 15 - On-state Power Loss Characteristics (Single Phase Bridge IRKU+IRKV)

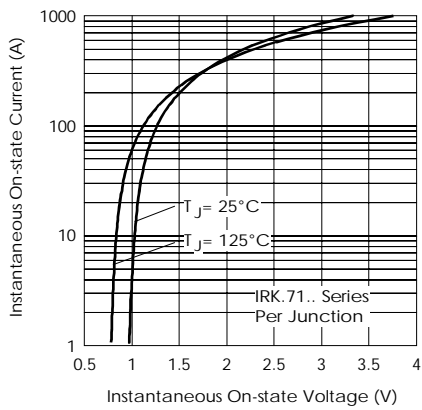
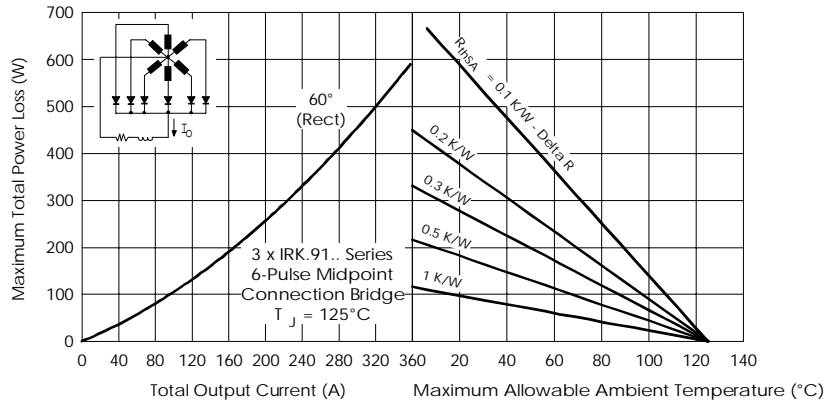

Fig. 17 - On-state Voltage Drop Characteristics

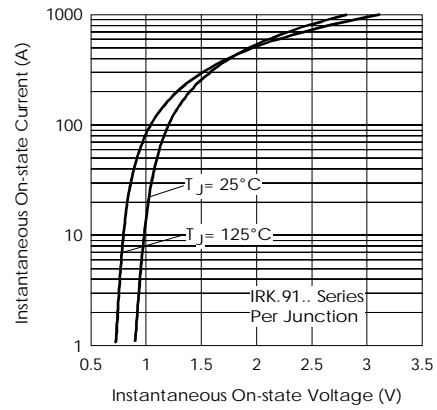

Fig. 18 - On-state Voltage Drop Characteristics

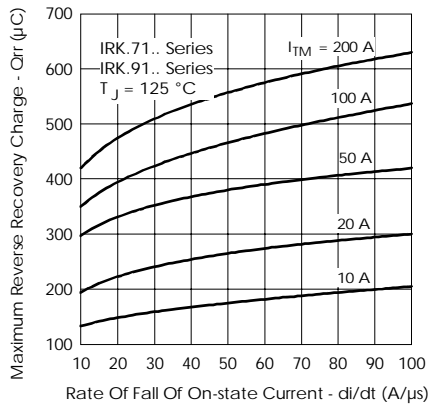

Fig. 19 - Recovery Charge Characteristics

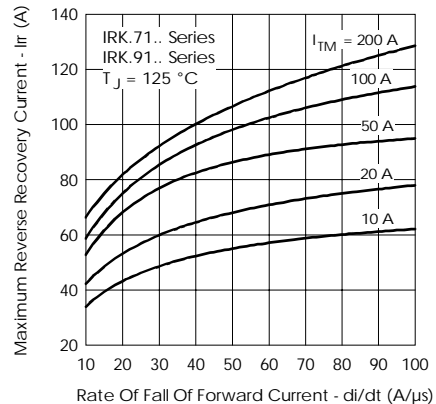

Fig. 20 - Recovery Current Characteristics

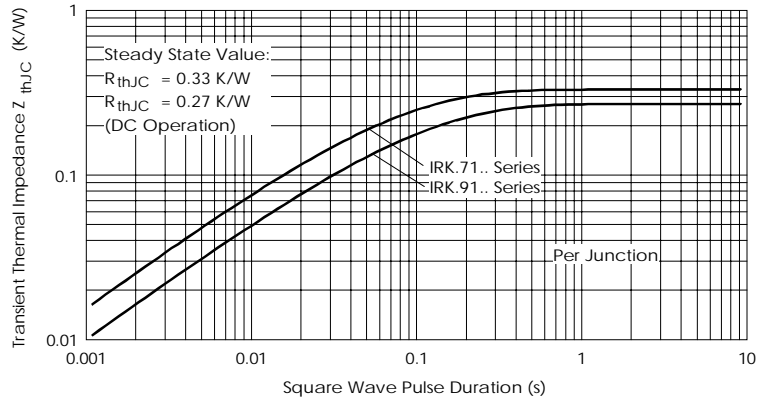

Fig. 21 - Thermal Impedance Z_{thJC} Characteristics

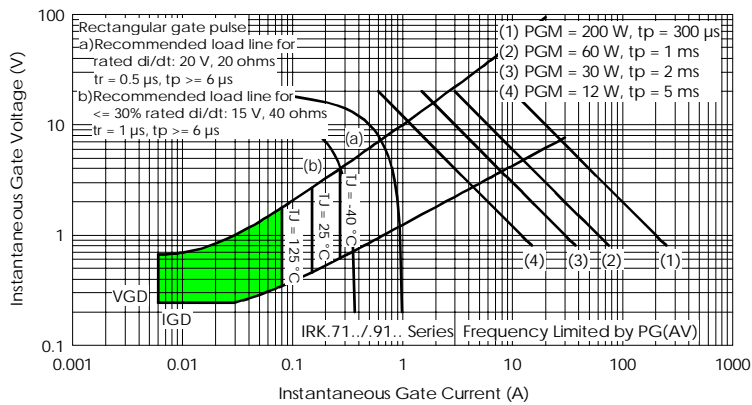

Fig. 22 - Gate Characteristics

Data and specifications subject to change without notice.
This product has been designed and qualified for Industrial Level.
Qualification Standards can be found on IR's Web site.