

# Three Phase AC Controller Modules

$$I_{RMS} = 3 \times 143 \text{ A}$$

$$V_{RRM} = 1200-1600 \text{ V}$$

Preliminary data

$V_{RSM}$	$V_{RRM}$	Type
$V_{DSM}$	$V_{DRM}$	
V	V	
1200	1200	VWO 140-12io1
1400	1400	VWO 140-14io1
1600	1600	VWO 140-16io1

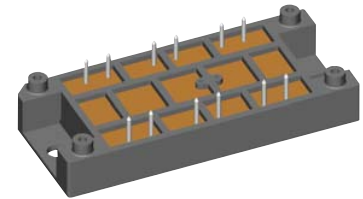
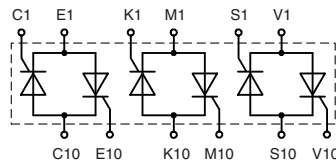

pin configuration see outlines

Symbol	Conditions	Maximum Ratings	
$I_{RMS}$	$T_C = 85^\circ\text{C}$ ; 50 - 400 Hz (per phase)	101	A
$I_{RMS}$	$T_C = 85^\circ\text{C}$ ; 50 - 400 Hz (per phase) for 10 sec.	143	A
$I_{TAVM}$	$T_C = 85^\circ\text{C}$ ; (180° sine)	46	A
$I_{TSM}$	$T_{VJ} = 45^\circ\text{C}$	$t = 10 \text{ ms}$ (50 Hz), sine	1150 A
	$V_R = 0$	$t = 8.3 \text{ ms}$ (60 Hz), sine	1240 A
$I^2t$	$T_{VJ} = 45^\circ\text{C}$	$t = 10 \text{ ms}$ (50 Hz), sine	6610 A <sup>2</sup> s
	$V_R = 0$	$t = 8.3 \text{ ms}$ (60 Hz), sine	6460 A <sup>2</sup> s
$(di/dt)_{cr}$	$T_{VJ} = 125^\circ\text{C}$	repetitive, $I_T = 45 \text{ A}$	150 A/ $\mu\text{s}$
	$f = 50 \text{ Hz}$ , $t_p = 200 \mu\text{s}$ $V_D = \frac{2}{3} V_{DRM}$ $I_G = 0.45 \text{ A}$ $di_G/dt = 0.45 \text{ A}/\mu\text{s}$	non repetitive, $I_T = I_{TAVM}$	500 A/ $\mu\text{s}$
$(dv/dt)_{cr}$	$T_{VJ} = 125^\circ\text{C}$ ; $R_{GK} = \infty$ ; method 1 (linear voltage rise)	$V_{DR} = \frac{2}{3} V_{DRM}$	1000 V/ $\mu\text{s}$
$P_{GM}$	$T_{VJ} = 125^\circ\text{C}$ $I_T = I_{TAVM}$	$t_p = 30 \mu\text{s}$	10 W
		$t_p = 300 \mu\text{s}$	5 W
$P_{GAVM}$			0.5 W
$V_{RGM}$			10 V
$T_{VJ}$		-40...+125	°C
$T_{VJM}$	for 10 sec.	150	°C
$T_{stg}$		-40...+125	°C
$V_{ISOL}$	50/60 Hz, RMS	$t = 1 \text{ min}$	3000 V~
	$I_{ISOL} \leq 1 \text{ mA}$	$t = 1 \text{ s}$	3600 V~
$M_d$	Mounting torque (M5)		2-2.5 Nm.
			18-22 lb.in.
<b>Weight</b>	typ.		80 g

Data according to IEC 60747 refer to a single thyristor unless otherwise stated.

**Features**

- Thyristor controller for AC (circuit W3C acc. to IEC) for mains frequency
- Package with DCB base plate
- Isolation voltage 3600 V~
- Planar passivated chips
- UL applied

**Applications**

- Switching and control of three phase AC circuits
- Softstart AC motor controller
- Solid state switches
- Light and temperature control

**Advantages**

- Easy to mount with two screws
- Space and weight savings
- Improved temperature and power cycling
- High power density

Symbol	Conditions	Characteristic Values	
$I_D, I_R$	$T_{VJ} = 125^\circ\text{C}; V_R = V_{RRM}; V_D = V_{DRM}$	$\leq$	5 mA
$V_T$	$I_T = 140 \text{ A}; T_{VJ} = 25^\circ\text{C}$	$\leq$	1.5 V
$V_{T0}$	For power-loss calculations only		0.85 V
$r_T$			5.2 m $\Omega$
$V_{GT}$	$V_D = 6 \text{ V}; T_{VJ} = 25^\circ\text{C}$	$\leq$	1.5 V
	$T_{VJ} = -40^\circ\text{C}$	$\leq$	1.6 V
$I_{GT}$	$V_D = 6 \text{ V}; T_{VJ} = 25^\circ\text{C}$	$\leq$	100 mA
	$T_{VJ} = -40^\circ\text{C}$	$\leq$	200 mA
$V_{GD}$	$T_{VJ}=125^\circ\text{C}; V_D = 2/3 V_{DRM}$	$\leq$	0.2 V
$I_{GD}$		$\leq$	5 mA
$I_L$	$T_{VJ} = 25^\circ\text{C}; t_p = 10 \mu\text{s}$ $I_G = 0.45 \text{ A}; di_G/dt = 0.45 \text{ A}/\mu\text{s}$	$\leq$	450 mA
$I_H$	$T_{VJ} = 25^\circ\text{C}; V_D = 6 \text{ V}; R_{GK} = \infty$	$\leq$	200 mA
$t_{gd}$	$T_{VJ} = 25^\circ\text{C}; V_D = 1/2 V_{DRM}$ $I_G = 0.45 \text{ A}; di_G/dt = 0.45 \text{ A}/\mu\text{s}$	$\leq$	2 $\mu\text{s}$
$t_q$	$T_{VJ}=125^\circ\text{C}; I_T = 20 \text{ A}, t_p = 200 \mu\text{s}; di/dt = -10 \text{ A}/\mu\text{s}$ typ. $V_R = 100 \text{ V}; dv/dt = 15 \text{ V}/\mu\text{s}; V_D = 2/3 V_{DRM}$		150 $\mu\text{s}$
$R_{thJC}$	per thyristor; sine $180^\circ\text{el}$ per module		0.6 K/W 0.1 K/W
$R_{thJK}$	per thyristor; sine $180^\circ\text{el}$ per module		0.7 K/W 0.117 K/W
$d_s$	Creeping distance on surface		12.7 mm
$d_A$	Creepage distance in air		9.4 mm
$a$	Max. allowable acceleration		50 m/s <sup>2</sup>

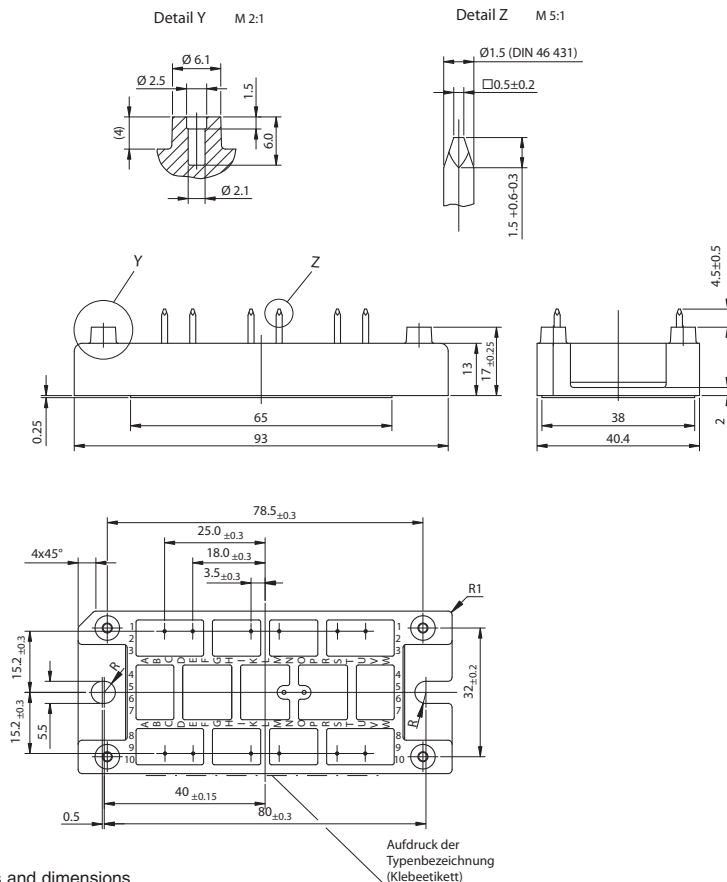
**Dimensions in mm (1 mm = 0.0394")**

IXYS reserves the right to change limits, test conditions and dimensions.

20080828a