

# Three Phase Rectifier Bridge

**I<sub>dAV</sub> = 70 A**  
**V<sub>RRM</sub> = 800-1600 V**

Preliminary data

V <sub>RSM</sub> V <sub>DSM</sub> V	V <sub>RRM</sub> V <sub>DRM</sub> V	Type
800	800	xxx 70-08io7
1200	1200	xxx 70-12io7
1400	1400	xxx 70-14io7
1600	1600	xxx 70-16io7
xxx = type		

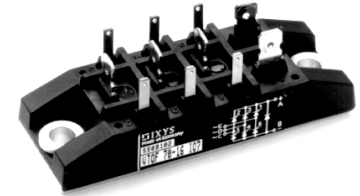
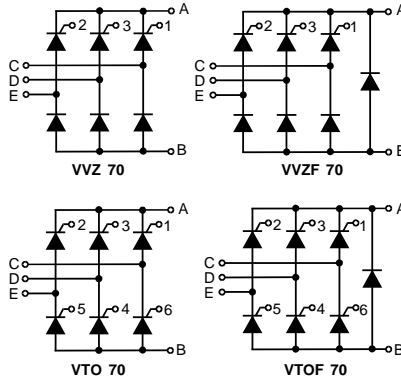

Symbol	Test Conditions	Maximum Ratings
I <sub>dAV</sub> ①	T <sub>C</sub> = 85°C, module	70 A
I <sub>dAVM</sub> ①	module	70 A
I <sub>FRMS</sub> , I <sub>TRMS</sub>	per leg	36 A
I <sub>FSM</sub> , I <sub>TSM</sub>	T <sub>VJ</sub> = 45°C; V <sub>R</sub> = 0 V	t = 10 ms (50 Hz), sine 550 A t = 8.3 ms (60 Hz), sine 600 A
	T <sub>VJ</sub> = T <sub>VJM</sub> V <sub>R</sub> = 0 V	t = 10 ms (50 Hz), sine 500 A t = 8.3 ms (60 Hz), sine 550 A
I <sup>2</sup> t	T <sub>VJ</sub> = 45°C V <sub>R</sub> = 0 V	t = 10 ms (50 Hz), sine 1520 A <sup>2</sup> s t = 8.3 ms (60 Hz), sine 1520 A <sup>2</sup> s
	T <sub>VJ</sub> = T <sub>VJM</sub> V <sub>R</sub> = 0 V	t = 10 ms (50 Hz), sine 1250 A <sup>2</sup> s t = 8.3 ms (60 Hz), sine 1250 A <sup>2</sup> s
(di/dt) <sub>cr</sub>	T <sub>VJ</sub> = 125°C f = 50 Hz, t <sub>p</sub> = 200 μs V <sub>D</sub> = 2/3 V <sub>DRM</sub> I <sub>G</sub> = 0.3 A, di <sub>G</sub> /dt = 0.3 A/μs	repetitive, I <sub>T</sub> = 50 A 150 A/μs non repetitive, I <sub>T</sub> = 1/2 • I <sub>dAV</sub> 500 A/μs
	(dv/dt) <sub>cr</sub>	T <sub>VJ</sub> = T <sub>VJM</sub> ; V <sub>DR</sub> = 2/3 V <sub>DRM</sub> R <sub>GK</sub> = ∞; method 1 (linear voltage rise)
V <sub>RGM</sub>		10 V
P <sub>GM</sub>	T <sub>VJ</sub> = T <sub>VJM</sub> I <sub>T</sub> = I <sub>TAVM</sub>	t <sub>p</sub> = 30 μs ≤ 10 W
		t <sub>p</sub> = 500 μs ≤ 5 W
		t <sub>p</sub> = 10 ms ≤ 1 W
P <sub>GAVM</sub>		0.5 W
T <sub>VJ</sub>		-40...+125 °C
T <sub>VJM</sub>		125 °C
T <sub>stg</sub>		-40...+125 °C
V <sub>ISOL</sub>	50/60 Hz, RMS	t = 1 min 2500 V~
	I <sub>ISOL</sub> ≤ 1 mA	t = 1 s 3000 V~
M <sub>d</sub>	Mounting torque (M5) (10-32 UNF)	5 ± 15 % Nm
		44 ± 15 % lb.in.
Weight		50 g

### Features

- Package with copper base plate
- Isolation voltage 3000 V~
- Planar passivated chips
- Low forward voltage drop
- ¼" fast-on power terminals

### Applications

- Supplies for DC power equipment
- Input rectifiers for PWM inverter
- Battery DC power supplies
- Field supply for DC motors

### Advantages

- Easy to mount with two screws
- Space and weight savings
- Improved temperature and power cycling capability
- Small and light weight

### Dimensions in mm (1 mm = 0.0394")

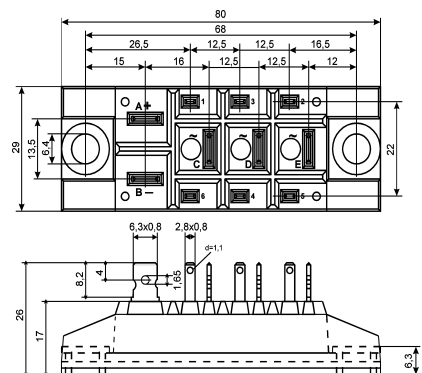

Data according to IEC 60747 refer to a single diode/thyristor unless otherwise stated

① for resistive load at bridge output. IXYS reserves the right to change limits, test conditions and dimensions.

© 2000 IXYS All rights reserved

008

Symbol	Test Conditions	Characteristic Values
$I_D, I_R$	$T_{VJ} = T_{VJM}; V_R = V_{RRM}; V_D = V_{DRM}$	$\leq 5$ mA
$V_T$	$I_T = 80$ A; $T_{VJ} = 25^\circ\text{C}$	$\leq 1.64$ V
$V_{T0}$	For power-loss calculations only	0.85 V
$r_T$		11 m $\Omega$
$V_{GT}$	$V_D = 6$ V; $T_{VJ} = 25^\circ\text{C}$	$\leq 1.5$ V
	$T_{VJ} = -40^\circ\text{C}$	$\leq 1.6$ V
$I_{GT}$	$V_D = 6$ V; $T_{VJ} = 25^\circ\text{C}$	$\leq 100$ mA
	$T_{VJ} = -40^\circ\text{C}$	$\leq 200$ mA
$V_{GD}$	$T_{VJ} = T_{VJM}; V_D = 2/3 V_{DRM}$	$\leq 0.2$ V
$I_{GD}$		$\leq 5$ mA
$I_L$	$T_{VJ} = 25^\circ\text{C}; t_p = 10$ $\mu\text{s}$ $I_G = 0.45$ A; $di_G/dt = 0.45$ A/ $\mu\text{s}$	$\leq 450$ mA
$I_H$	$T_{VJ} = 25^\circ\text{C}; V_D = 6$ V; $R_{GK} = \infty$	$\leq 200$ mA
$t_{gd}$	$T_{VJ} = 25^\circ\text{C}; V_D = 1/2 V_{DRM}$ $I_G = 0.45$ A; $di_G/dt = 0.45$ A/ $\mu\text{s}$	$\leq 2$ $\mu\text{s}$
$t_q$	$T_{VJ} = T_{VJM}; I_T = 20$ A, $t_p = 200$ $\mu\text{s}$ ; $di/dt = -10$ A/ $\mu\text{s}$ typ. $V_R = 100$ V; $dv/dt = 15$ V/ $\mu\text{s}$ ; $V_D = 2/3 V_{DRM}$	250 $\mu\text{s}$
$R_{thJC}$	per thyristor / Diode; DC	0.9 K/W
	per module	0.15 K/W
$R_{thJH}$	per thyristor / Diode; DC	1.1 K/W
	per module	0.157 K/W
$d_s$	Creeping distance on surface	16.1 mm
$d_A$	Creepage distance in air	7.5 mm
$a$	Max. allowable acceleration	50 m/s <sup>2</sup>