



FCAS20DN60BB

Smart Power Module for SRM

Features

- 600V-20A 2-phase asymmetric bridge IGBT converter for SRM drive including control ICs for gate driving and protection
- Single-grounded power supply due to built-in HVIC
- Isolation rating of 1500Vrms/min.
- Embedded bootstrap diode in the package

Applications

- 2-phase SRM drives for home application vacuum cleaner.

General Description

FCAS20DN60BB is an advanced smart power module for SRM drive that Fairchild has newly developed and designed to provide very compact and high performance SRM motor drives mainly targeting low-power SRM application especially for a vacuum air cleaner. It combines optimized circuit protection and drive matched to low-loss IGBTs. System reliability is further enhanced by the integrated under-voltage lock-out and short-circuit protection. The high speed built-in HVIC provides optocoupler-less IGBT gate driving capability that further reduce the overall size of the system. In addition the incorporated HVIC facilitates the use of single-supply drive topology enabling the FCAS20DN60BB to be driven by only one drive supply voltage without negative bias.

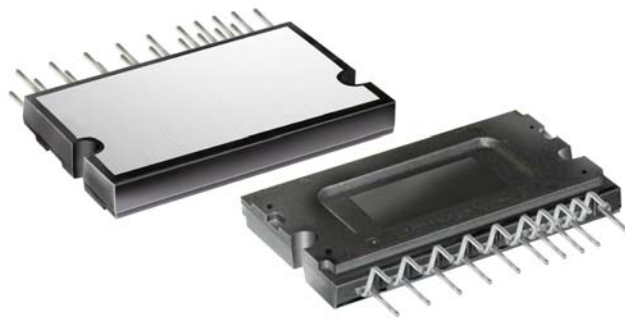

Figure 1.

Integrated Power Functions

- 600V-20A IGBT asymmetric converter for 2-phase SRM drives (Please refer to Figure 3)

Integrated Drive, Protection and System Control Functions

- For high-side IGBTs: Gate drive circuit, High voltage isolated high-speed level shifting
Control circuit under-voltage (UV) protection
Note) Available bootstrap circuit example is given in Figures 11.
- For low-side IGBTs: Gate drive circuit, Short circuit protection (SC)
Control supply circuit under-voltage (UV) protection
- Fault signaling: Corresponding to a UV fault (Low-side supply)
- Input interface: 5V CMOS/LSTTL compatible, Schmitt trigger input

Pin Configuration

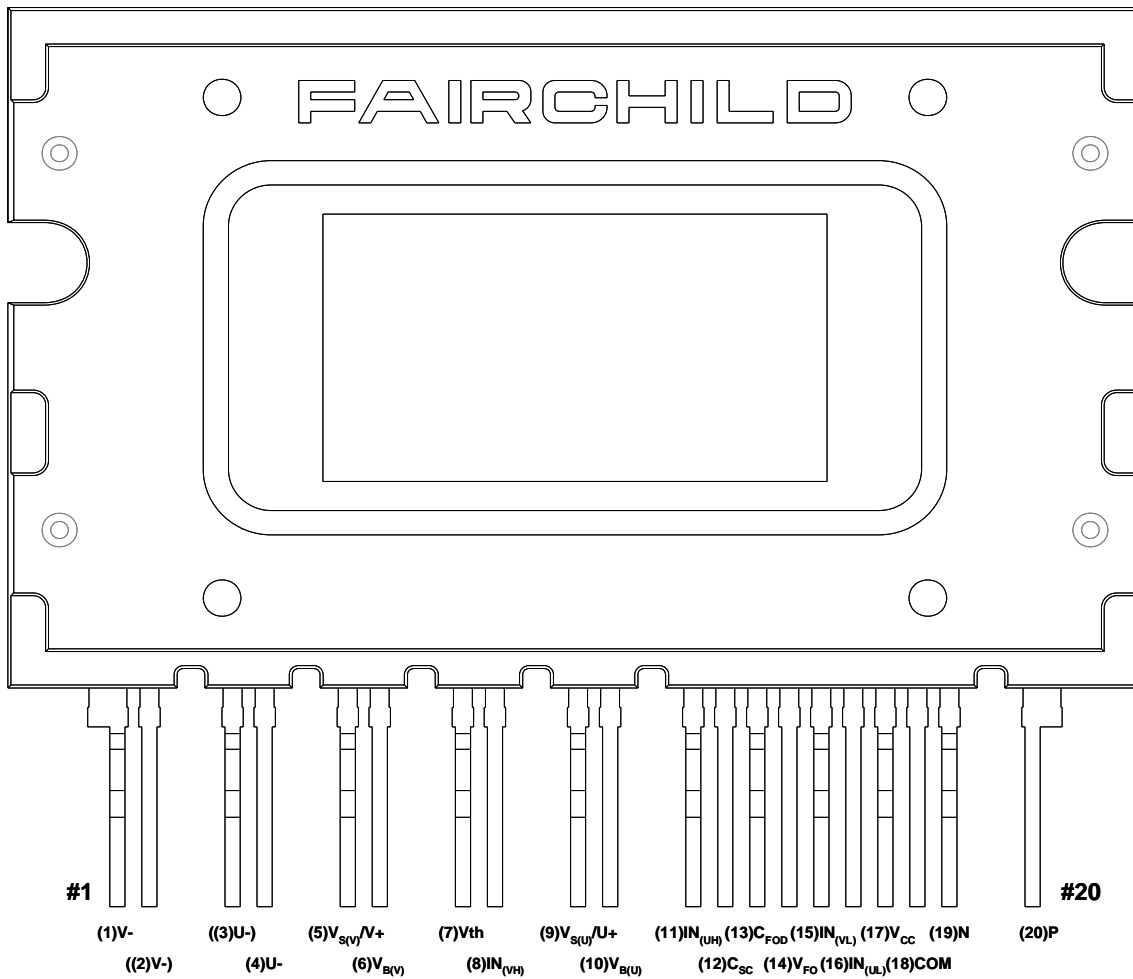

Pin Descriptions

Pin Number	Pin Name	Pin Description
1	V-	Output for V- Leg
2	(V-)	Output for V- Leg
3	(U-)	Output for U- Leg
4	U-	Output for U- Leg
5	VS(V)/V+	Output for V+ Leg / High-side Bias Voltage Ground for V-phase IGBT Gate Driving
6	VB(V)	High-side Bias Voltage for V-phase IGBT Gate Driving
7	Vth	Thermistor Output
8	IN(VH)	Signal Input for V-phase High-side IGBT
9	VS(U)/U+	Output for U+ Leg / High-side Bias Voltage Ground for U-phase IGBT Gate Driving
10	VB(U)	High-side Bias Voltage for U-phase IGBT Gate Driving
11	IN(UH)	Signal Input for U-phase High-side IGBT
12	C _{SC}	Capacitor (Low-pass Filter) for Short-Current Detection
13	C _{FOD}	Capacitor for Fault Output Duration Time Selection
14	V _{FO}	Fault Output
15	IN(VL)	Signal Input for V-phase Low-side IGBT
16	IN(UL)	Signal Input for U-phase Low-side IGBT
17	V _{CC}	Common Bias Voltage for IC and IGBTs Driving
18	COM	Common Supply Ground
19	N	Negative DC-Link Input
20	P	Positive DC-Link Input

Internal Equivalent Circuit and Input/Output Pins

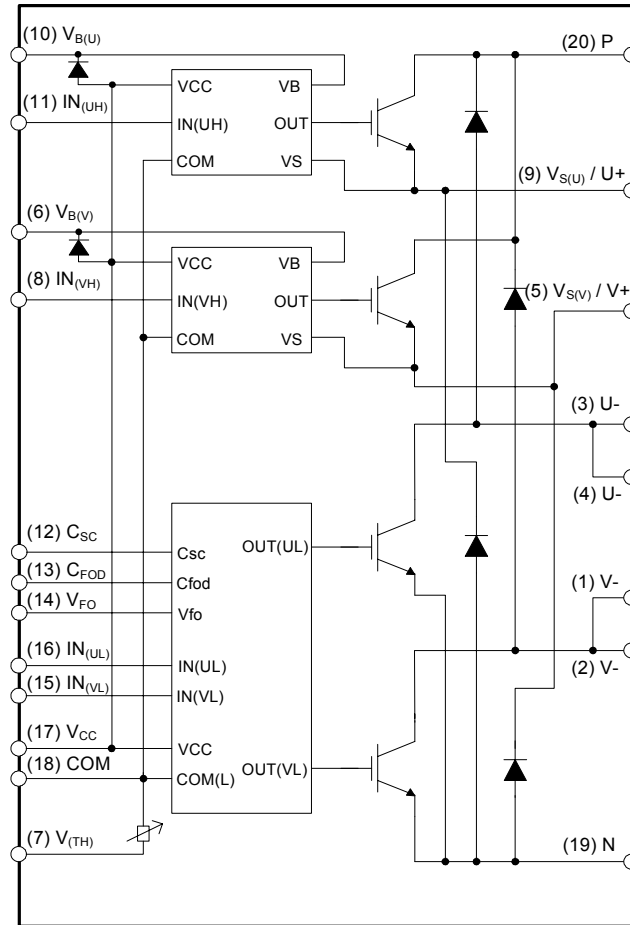

Figure 3.

Absolute Maximum Ratings ($T_J = 25^\circ\text{C}$, Unless Otherwise Specified)**Inverter Part**

Symbol	Parameter	Conditions	Rating	Units
$V_{PN(\text{Surge})}$	Supply Voltage (Surge)	Applied between P- N	550	V
V_{CES}	Collector-emitter Voltage		600	V
$\pm I_C$	Each IGBT Collector Current	$T_C = 25^\circ\text{C}$	20	A
$\pm I_{CP}$	Each IGBT Collector Current (Peak)	$T_C = 25^\circ\text{C}$, Under 1ms Pulse Width	30	A
P_C	Collector Dissipation	$T_C = 25^\circ\text{C}$ per One IGBT	22	W
T_J	Operating Junction Temperature	(Note 1)	-20 ~ 125	$^\circ\text{C}$

Control Part

Symbol	Parameter	Conditions	Rating	Units
V_{CC}	Control Supply Voltage	Applied between V_{CC} - COM	20	V
V_{BS}	High-side Control Bias Voltage	Applied between $V_B - V_S$	20	V
V_{IN}	Input Signal Voltage	Applied between $IN_{(H)}$, $IN_{(L)}$ - COM	-0.3~17	V
V_{FO}	Fault Output Supply Voltage	Applied between V_{FO} - COM	-0.3~ $V_{CC}+0.3$	V
I_{FO}	Fault Output Current	Sink Current at V_{FO} Pin	5	mA
V_{SC}	Current Sensing Input Voltage	Applied between C_{SC} - COM	-0.3~ $V_{CC}+0.3$	V

Total System

Symbol	Parameter	Conditions	Rating	Units
$V_{PN(\text{PROT})}$	Self Protection Supply Voltage Limit (Short Circuit Protection Capability)	$V_{CC} = V_{BS} = 13.5 \sim 16.5\text{V}$ $T_J = 125^\circ\text{C}$, Non-repetitive, less than 2 μs	400	V
T_{STG}	Storage Temperature		-40 ~ 125	$^\circ\text{C}$
V_{ISO}	Isolation Voltage	60Hz, Sinusoidal, AC 1 minute, Connection Pins to IMS	1500	V_{rms}

Thermal Resistance

Symbol	Parameter	Conditions	Min.	Typ.	Max.	Units
$R_{th(j-c)Q}$	Junction to Case Thermal Resistance	Each IGBT under Operating Condition	-	-	4.0	$^\circ\text{C/W}$
$R_{th(j-c)F}$		Each FWDi under Operating Condition	-	-	9.4	$^\circ\text{C/W}$

Note:

1. For the measurement point of case temperature (T_C), please refer to Figure 2.

Package Marking & Ordering Information

Device Marking	Device	Package	Reel Size	Tape Width	Quantity
FCAS20DN60BB	FCAS20DN60BB	SPM20-BC	-	-	11

Electrical Characteristics ($T_J = 25^\circ\text{C}$, Unless Otherwise Specified)

Inverter Part

Symbol	Parameter	Conditions		Min.	Typ.	Max.	Units	
$V_{CE(SAT)}$	Collector-Emitter Saturation Voltage	$V_{CC} = V_{BS} = 15\text{V}$ $V_{IN} = 5\text{V}$	$I_C = 15\text{A}$, $T_J = 25^\circ\text{C}$	-	-	2.05	V	
V_{FM}	FWDi Forward Voltage	$V_{IN} = 0\text{V}$	$I_C = 15\text{A}$, $T_J = 25^\circ\text{C}$	-	-	2.8	V	
HS	t_{ON}	Switching Times	$V_{PN} = 300\text{V}$, $V_{CC} = V_{BS} = 15\text{V}$ $I_C = 20\text{A}$ $V_{IN} = 0\text{V} \leftrightarrow 5\text{V}$, Inductive Load (Note 2)	-	680	-	ns	
				$t_{C(ON)}$	-	500	-	ns
				t_{OFF}	-	1130	-	ns
				$t_{C(OFF)}$	-	160	-	ns
				t_{rr}	-	85	-	ns
LS	t_{ON}	Switching Times	$V_{PN} = 300\text{V}$, $V_{CC} = V_{BS} = 15\text{V}$ $I_C = 20\text{A}$ $V_{IN} = 0\text{V} \leftrightarrow 5\text{V}$, Inductive Load (Note 2)	-	1000	-	ns	
				$t_{C(ON)}$	-	1100	-	ns
				t_{OFF}	-	1050	-	ns
				$t_{C(OFF)}$	-	180	-	ns
				t_{rr}	-	80	-	ns
I_{CES}	Collector - Emitter Leakage Current	$V_{CE} = V_{CES}$		-	-	250	μA	

Note:

2. t_{ON} and t_{OFF} include the propagation delay time of the internal drive IC. $t_{C(ON)}$ and $t_{C(OFF)}$ are the switching time of IGBT itself under the given gate driving condition internally. For the detailed information, please see Figure 4.

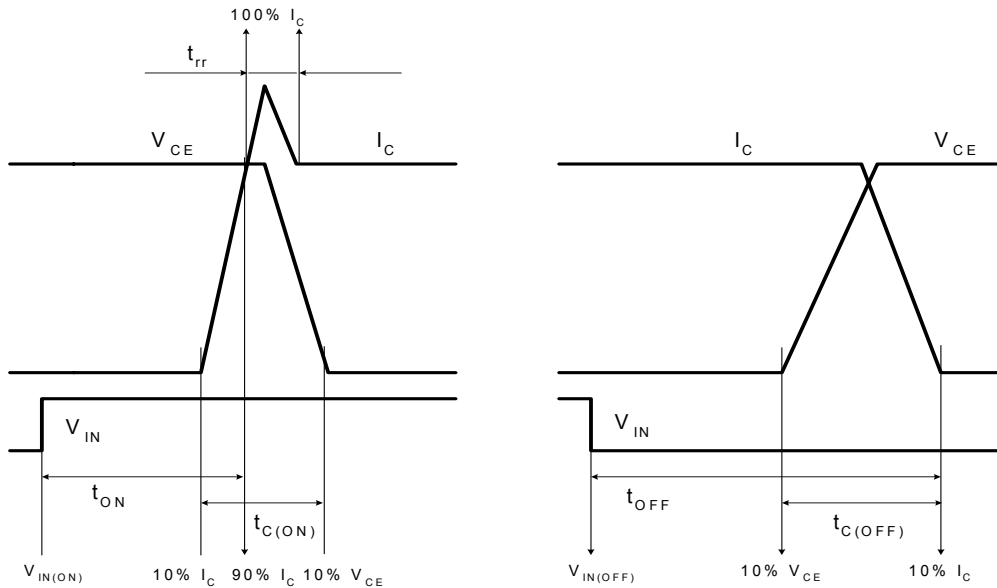

Figure 4. Switching Time Definition

Electrical Characteristics ($T_J = 25^\circ\text{C}$, Unless Otherwise Specified)**Control Part**

Symbol	Parameter	Conditions		Min.	Typ.	Max.	Units
I_{QCC}	Quiescent V_{CC} Supply Current	$V_{\text{CC}} = 15\text{V}$ $I_{\text{N(L)}} = 0\text{V}$	$V_{\text{CC}} - \text{COM}$	-	-	24	mA
I_{QBS}	Quiescent V_{BS} Supply Current	$V_{\text{BS}} = 15\text{V}$ $I_{\text{N(H)}} = 0\text{V}$	$V_{\text{B}} - V_{\text{S}}$	-	-	500	μA
V_{FOH}	Fault Output Voltage	$V_{\text{SC}} = 0\text{V}$, V_{FO} Circuit: 4.7k Ω to 5V Pull-up		4.5	-	-	V
V_{FOL}		$V_{\text{SC}} = 1\text{V}$, V_{FO} Circuit: 4.7k Ω to 5V Pull-up		-	-	0.8	V
$V_{\text{SC(ref)}}$	Short Circuit Trip Level	$V_{\text{CC}} = 15\text{V}$ (Note 3)		0.45	0.5	0.55	V
UV_{CCD}	Supply Circuit Under-Voltage Protection	Detection Level	Applied between $V_{\text{CC}} - \text{COM}$	10.7	11.9	13.0	V
UV_{CCR}		Reset Level		11.2	12.4	13.2	V
UV_{BSD}		Detection Level	Applied between $V_{\text{B}} - V_{\text{S}}$	10.1	11.3	12.5	V
UV_{BSR}		Reset Level		10.5	11.7	12.9	V
t_{FOD}	Fault-out Pulse Width	$C_{\text{FOD}} = 33\text{nF}$ (Note 4)		1.0	1.8	-	ms
V_{IH}	ON Threshold Voltage	Logic '1' input voltage	Applied between $I_{\text{N(H)}}, I_{\text{N(L)}} - \text{COM}$	3.0	-	-	V
V_{IL}	OFF Threshold Voltage	Logic '0' input voltage		-	-	0.8	V
R_{TH}	Resistance of Thermistor	@ $T_{\text{C}} = 25^\circ\text{C}$ (Note Fig. 9)		-	50	-	k Ω
		@ $T_{\text{C}} = 80^\circ\text{C}$ (Note Fig. 9)		-	6.021	-	k Ω

Note:

- Short-circuit current protection is functioning only at the low-sides.
- The fault-out pulse width t_{FOD} depends on the capacitance value of C_{FOD} according to the following approximate equation : $C_{\text{FOD}} = 18.3 \times 10^{-6} \times t_{\text{FOD}}[\text{F}]$

Recommended Operating Conditions

Symbol	Parameter	Conditions	Value			Units
			Min.	Typ.	Max.	
V_{PN}	Supply Voltage	Applied between P - N	-	300	450	V
V_{CC}	Control Supply Voltage	Applied between $V_{\text{CC}} - \text{COM}$	13.5	15	16.5	V
V_{BS}	High-side Bias Voltage	Applied between $V_{\text{B}} - V_{\text{S}}$	13.5	15	18.5	V
f_{PWM}	PWM Input Signal	$T_{\text{C}} \leq 100^\circ\text{C}$, $T_{\text{J}} \leq 125^\circ\text{C}$	-	3	-	kHz
$V_{\text{IN(ON)}}$	Input ON Voltage	Applied between $I_{\text{N(H)}}, I_{\text{N(L)}} - \text{COM}$	4 ~ 5.5			V
$V_{\text{IN(OFF)}}$	Input OFF Voltage	Applied between $I_{\text{N(H)}}, I_{\text{N(L)}} - \text{COM}$	0 ~ 0.65			V

Bootstrap Diode Part

Symbol	Parameter	Conditions	Rating	Units
V_{RRM}	Maximum Repetitive Reverse Voltage		600	V
I_{F}	Forward Current	$T_{\text{C}} = 25^\circ\text{C}$	0.5	A
I_{FP}	Forward Current (Peak)	$T_{\text{C}} = 25^\circ\text{C}$, Under 1ms Pulse Width	2	A
T_{J}	Reverse Recovery Time		-20~125	$^\circ\text{C}$

Mechanical Characteristics and Ratings

Parameter	Conditions	Limits			Units
		Min.	Typ.	Max.	
Mounting Torque	Mounting Screw - M3	5.17	6.29	7.30	Kg•cm
		0.51	0.62	0.72	N•m
Surface Flatness	Note Figure 5.	-	-	-	um
Weight		-	14.5	-	g

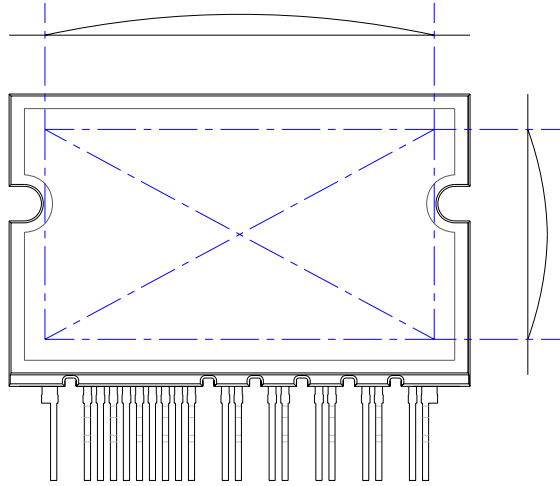
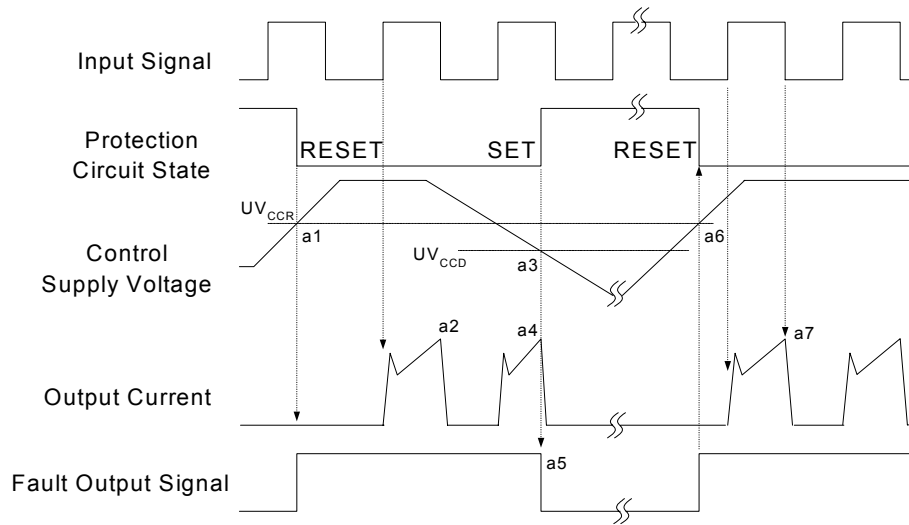

Figure 5. Flatness Measurement Position

Time Charts of Protective Function



- a1 : Control supply voltage rises: After the voltage rises UV_{CCR} , the circuits start to operate when next input is applied.
- a2 : Normal operation: IGBT ON and carrying current.
- a3 : Under voltage detection (UV_{CCD}).
- a4 : IGBT OFF in spite of control input condition.
- a5 : Fault output operation starts.
- a6 : Under voltage reset (UV_{CCR}).
- a7 : Normal operation: IGBT ON and carrying current.

Fig. 6. Under-Voltage Protection (Low-side)

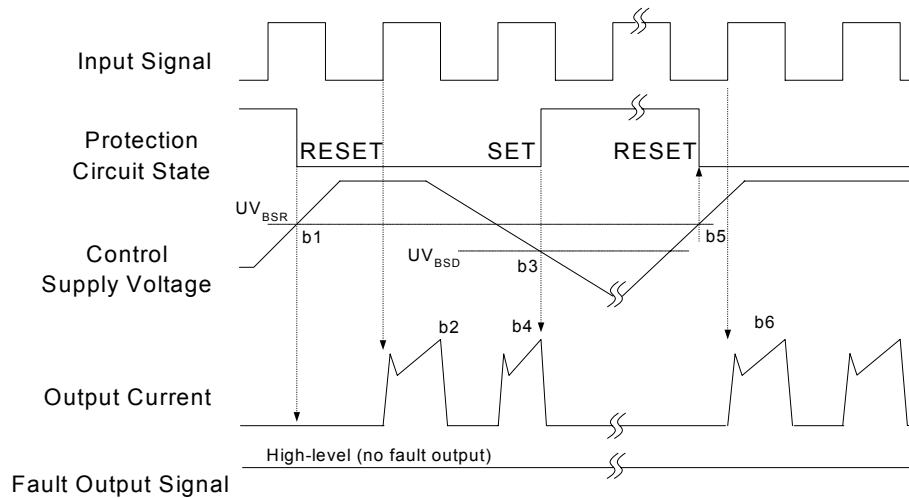

- b1 : Control supply voltage rises: After the voltage reaches UV_{BSR} , the circuits start to operate when next input is applied.
- b2 : Normal operation: IGBT ON and carrying current.
- b3 : Under voltage detection (UV_{BSD}).
- b4 : IGBT OFF in spite of control input condition, but there is no fault output signal.
- b5 : Under voltage reset (UV_{BSR})
- b6 : Normal operation: IGBT ON and carrying current

Fig. 7. Under-Voltage Protection (High-side)

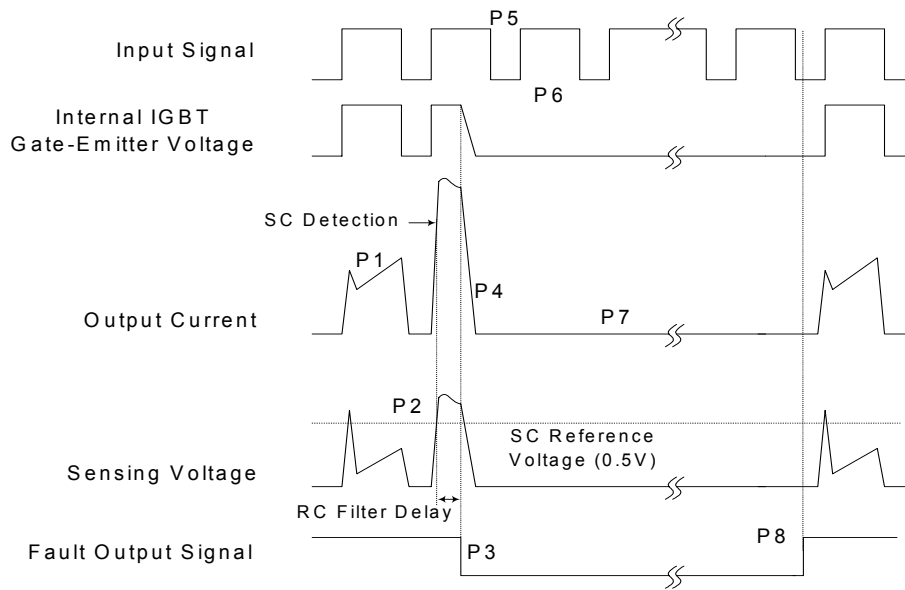

(with the external shunt resistance and CR connection)

- c1 : Normal operation: IGBT ON and carrying current.
- c2 : Short circuit current detection (SC trigger).
- c3 : Hard IGBT gate interrupt.
- c4 : IGBT turns OFF.
- c5 : Fault output timer operation starts: The pulse width of the fault output signal is set by the external capacitor C_{FO} .
- c6 : Input "L" : IGBT OFF state.
- c7 : Input "H": IGBT ON state, but during the active period of fault output the IGBT doesn't turn ON.
- c8 : IGBT OFF state

Fig. 8. Short-Circuit Current Protection (Low-side Operation only)

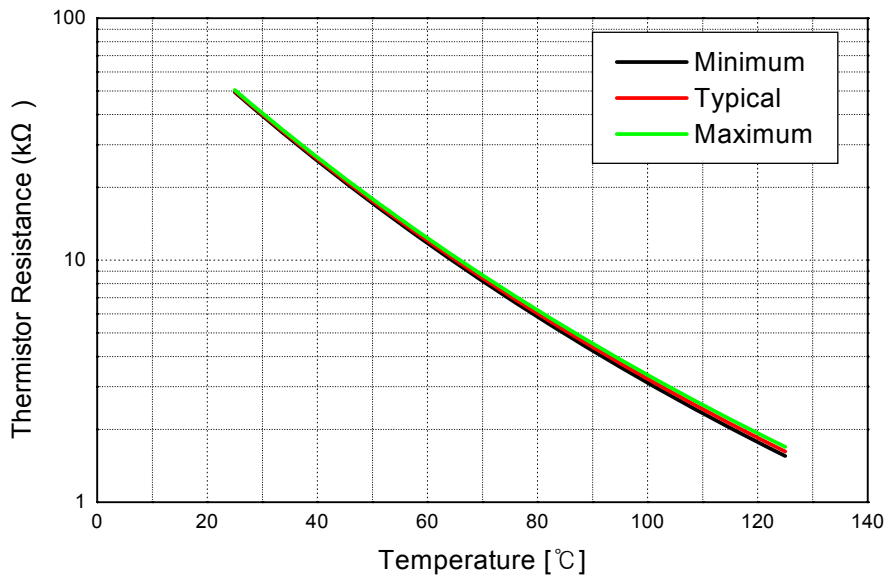
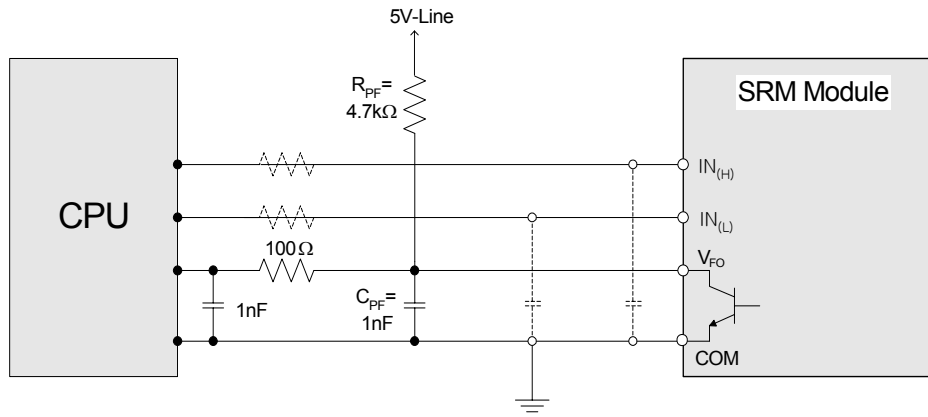

Fig. 9. R-T Curve of the Built-in Thermistor



Note:

- 5. RC coupling at each input (parts shown dotted) might change depending on the PWM control scheme used in the application and the wiring impedance of the application's printed circuit board. The input signal section integrates 3.3kΩ(typ.) pull-down resistor. Therefore, when using an external filtering resistor, please pay attention to the signal voltage drop at input terminal.
- 6. The logic input is compatible with standard CMOS or LSTTL outputs.

Figure 10. Recommended CPU I/O Interface Circuit

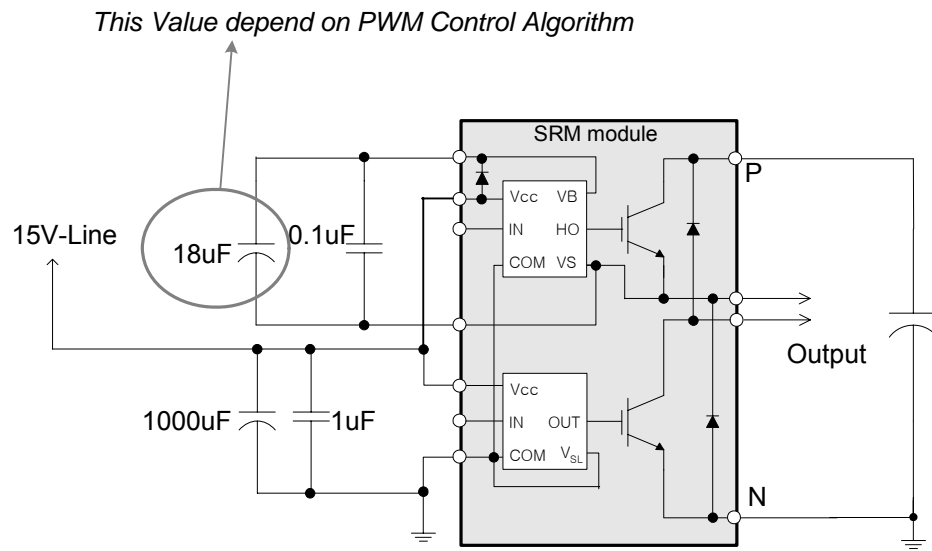

Note:

- 1) The ceramic capacitor placed between V_{CC}-COM should be over 1μF and mounted as close to the pins of the SPM as possible.

Figure 11. Recommended Bootstrap Operation Circuit and Parameters

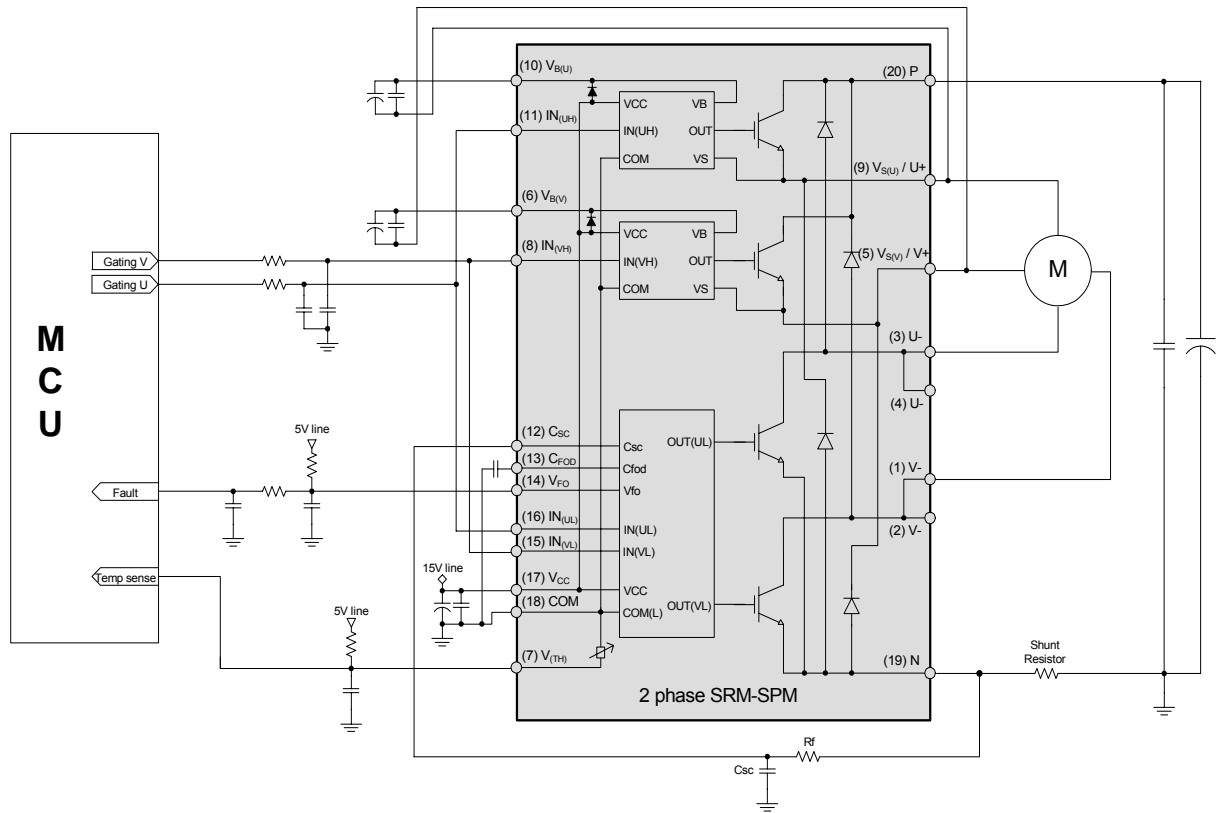



Figure 12. Typical Application Circuit



TRADEMARKS

The following includes registered and unregistered trademarks and service marks, owned by Fairchild Semiconductor and/or its global subsidiaries, and is not intended to be an exhaustive list of all such trademarks.

ACEx [®]	FPS [™]	PDP-SPM [™]	SupreMOS [™]
Build it Now [™]	FRFET [®]	Power220 [®]	SyncFET [™]
CorePLUS [™]	Global Power Resource SM	POWEREDGE [®]	SYSTEM [®]
CROSSVOLT [™]	Green FPS [™]	Power-SPM [™]	GENERAL [®]
CTL [™]	Green FPS [™] e-Series [™]	PowerTrench [®]	The Power Franchise [®]
Current Transfer Logic [™]	GTO [™]	Programmable Active Droop [™]	power [®]
EcoSPARK [®]	<i>i-Lo</i> [™]	QFET [®]	the
EZSWITCH [™] *	IntelliMAX [™]	QS [™]	franchise
 ™	ISOPLANAR [™]	QT Optoelectronics [™]	TinyBoost [™]
 ™	MegaBuck [™]	Quiet Series [™]	TinyBuck [™]
Fairchild [®]	MICROCOUPLER [™]	RapidConfigure [™]	TinyLogic [®]
Fairchild Semiconductor [®]	MicroFET [™]	SMART START [™]	TINYOPTO [™]
FACT Quiet Series [™]	MicroPak [™]	SPM [®]	TinyPower [™]
FACT [®]	MillerDrive [™]	STEALTH [™]	TinyPWM [™]
FAST [®]	Motion-SPM [™]	SuperFET [™]	TinyWire [™]
FastvCore [™]	OPTOLOGIC [®]	SuperSOT [™] -3	μSerDes [™]
FlashWriter [®] *	OPTOPLANAR [®]	SuperSOT [™] -6	UHC [®]
		SuperSOT [™] -8	Ultra FRFET [™]
			UniFET [™]
			VCX [™]

* EZSWITCH[™] and FlashWriter[®] are trademarks of System General Corporation, used under license by Fairchild Semiconductor.

DISCLAIMER

FAIRCHILD SEMICONDUCTOR RESERVES THE RIGHT TO MAKE CHANGES WITHOUT FURTHER NOTICE TO ANY PRODUCTS HEREIN TO IMPROVE RELIABILITY, FUNCTION, OR DESIGN. FAIRCHILD DOES NOT ASSUME ANY LIABILITY ARISING OUT OF THE APPLICATION OR USE OF ANY PRODUCT OR CIRCUIT DESCRIBED HEREIN; NEITHER DOES IT CONVEY ANY LICENSE UNDER ITS PATENT RIGHTS, NOR THE RIGHTS OF OTHERS. THESE SPECIFICATIONS DO NOT EXPAND THE TERMS OF FAIRCHILD'S WORLDWIDE TERMS AND CONDITIONS, SPECIFICALLY THE WARRANTY THEREIN, WHICH COVERS THESE PRODUCTS.

LIFE SUPPORT POLICY

FAIRCHILD'S PRODUCTS ARE NOT AUTHORIZED FOR USE AS CRITICAL COMPONENTS IN LIFE SUPPORT DEVICES OR SYSTEMS WITHOUT THE EXPRESS WRITTEN APPROVAL OF FAIRCHILD SEMICONDUCTOR CORPORATION.

As used herein:

1. Life support devices or systems are devices or systems which, (a) are intended for surgical implant into the body or (b) support or sustain life, and (c) whose failure to perform when properly used in accordance with instructions for use provided in the labeling, can be reasonably expected to result in a significant injury of the user.
2. A critical component in any component of a life support, device, or system whose failure to perform can be reasonably expected to cause the failure of the life support device or system, or to affect its safety or effectiveness.

PRODUCT STATUS DEFINITIONS

Definition of Terms

Datasheet Identification	Product Status	Definition
Advance Information	Formative or In Design	This datasheet contains the design specifications for product development. Specifications may change in any manner without notice.
Preliminary	First Production	This datasheet contains preliminary data; supplementary data will be published at a later date. Fairchild Semiconductor reserves the right to make changes at any time without notice to improve design.
No Identification Needed	Full Production	This datasheet contains final specifications. Fairchild Semiconductor reserves the right to make changes at any time without notice to improve the design.
Obsolete	Not In Production	This datasheet contains specifications on a product that has been discontinued by Fairchild Semiconductor. The datasheet is printed for reference information only.

Rev. I33