

Integrated Power Hybrid IC for
 Appliance Motor Drive Applications.

with Internal Shunt Resistor

Description

International Rectifier's IRAMX16UP60B is a 16A, 600V Integrated Power Hybrid IC with Internal Shunt Resistor for Appliance Motor Drives applications such as air conditioning systems and compressor drivers as well as for light industrial application. IR's technology offers an extremely compact, high performance AC motor-driver in a single isolated package to simplify design.

This advanced HIC is a combination of IR's low $V_{CE(on)}$ Punch-Through IGBT technology and the industry benchmark 3 phase high voltage, high speed driver in a fully isolated thermally enhanced package.

A built-in temperature monitor and over-current protection, along with the short-circuit rated IGBTs and integrated under-voltage lockout function, deliver high level of protection and fail-safe operation. Using a Single in line package (SiP2) with full transfer mold structure minimizes PCB space and resolve isolation problems to heatsink.

Features

- Internal Shunt Resistor
- Integrated Gate Drivers and Bootstrap Diodes
- Temperature Monitor
- Low $V_{CE(on)}$ Non Punch Through IGBT Technology
- Undervoltage lockout for all channels
- Matched propagation delay for all channels
- Schmitt-triggered input logic
- Cross-conduction prevention logic
- Lower di/dt gate driver for better noise immunity
- Motor Power range 0.75~2.2kW / 85~253 Vac
- Isolation 2000V_{RMS} min
- UL certification pending (UL number: E78996)



Absolute Maximum Ratings

| Parameter | Description | Value | Units |
|-------------------------|---|-------------|------------------|
| V_{CES} / V_{RRM} | IGBT/Diode Blocking Voltage | 600 | V |
| V^+ | Positive Bus Input Voltage | 450 | |
| $I_O @ T_C=25^\circ C$ | RMS Phase Current (Note 1) | 16 | A |
| $I_O @ T_C=100^\circ C$ | RMS Phase Current (Note 1) | 8 | |
| I_O | Pulsed RMS Phase Current (Note 2) | 30 | |
| F_{PWM} | PWM Carrier Frequency | 20 | kHz |
| P_D | Power dissipation per IGBT @ $T_C = 25^\circ C$ | 31 | W |
| V_{ISO} | Isolation Voltage (1min) | 2000 | V _{RMS} |
| T_J (IGBT & Diodes) | Operating Junction temperature Range | -40 to +150 | °C |
| T_J (Driver IC) | Operating Junction temperature Range | -40 to +150 | |
| T | Mounting torque Range (M3 screw) | 0.5 to 1.0 | Nm |

Note 1: Sinusoidal Modulation at $V^+ = 400V$, $T_J = 150^\circ C$, $F_{PWM} = 16kHz$, Modulation Depth=0.8, PF=0.6, See Figure 3.

Note 2: $t_p < 100ms$; $T_C = 25^\circ C$; $F_{PWM} = 16kHz$. Limited by $I_{BUS-ITRIP}$, see Table "Inverter Section Electrical Characteristics"

IRAMX16UP60B

Internal Electrical Schematic - IRAMX16UP60B

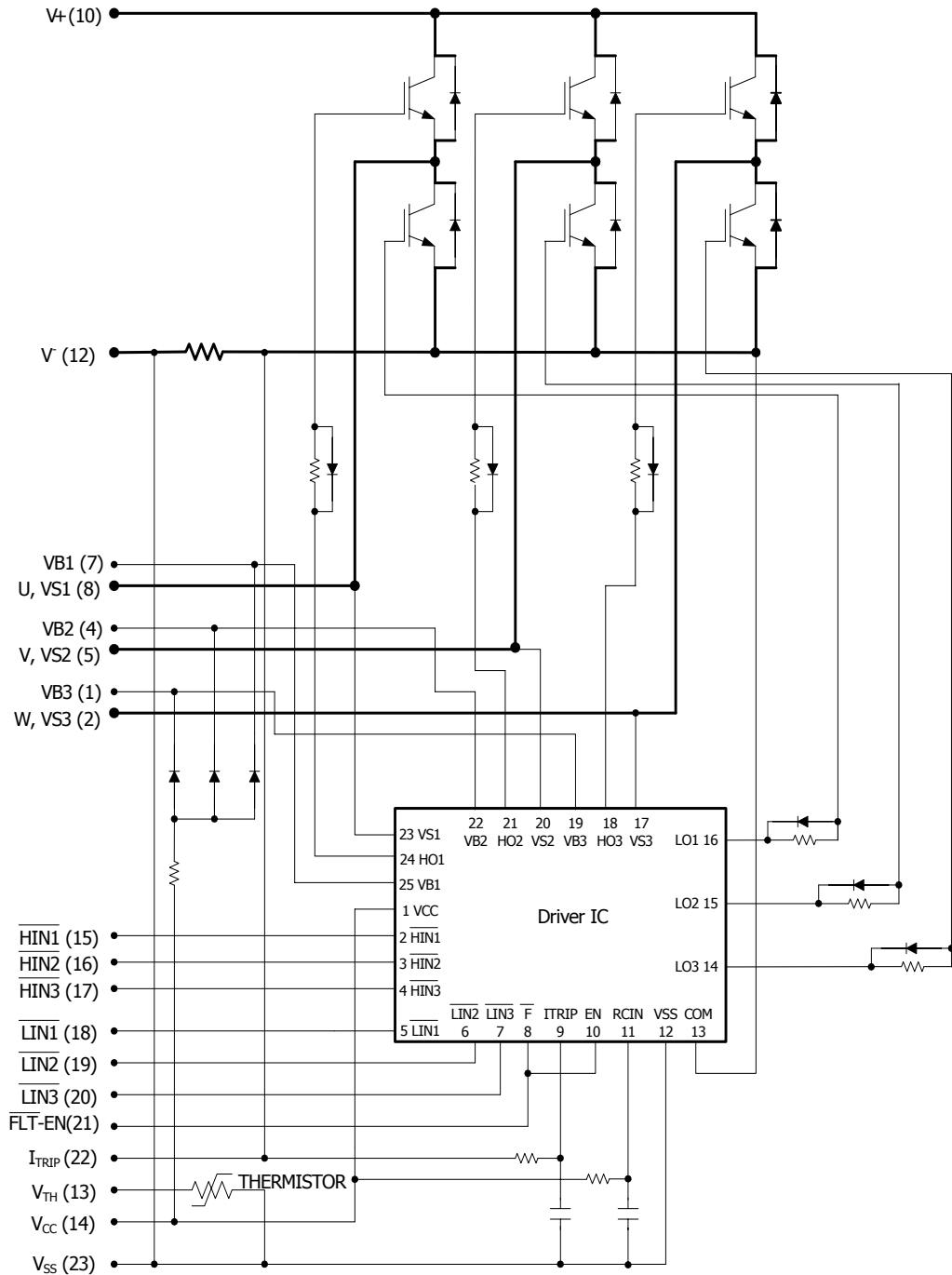

Absolute Maximum Ratings (Continued)

All voltages are absolute referenced to COM/I_{TRIP}.

| Symbol | Parameter | Min | Max | Units | Conditions |
|--|---|--------------------------|--|-------|---|
| I _{BDF} | Bootstrap Diode Peak Forward Current | --- | 4.5 | A | t _p = 10ms, T _J = 150°C, T _C =100°C |
| P _{BR Peak} | Bootstrap Resistor Peak Power (Single Pulse) | --- | 25.0 | W | t _p =100μs, T _C =100°C ESR / ERJ series |
| V _{S1,2,3} | High side floating supply offset voltage | V _{B1,2,3} - 25 | V _{B1,2,3} +0.3 | V | |
| V _{B1,2,3} | High side floating supply voltage | -0.3 | 600 | V | |
| V _{CC} | Low Side and logic fixed supply voltage | -0.3 | 20 | V | |
| V _{IN} , V _{EN} , V _{ITRIP} | Input voltage LIN, HIN, EN, I _{TRIP} | -0.3 | Lower of (V _{SS} +15V) or V _{CC} +0.3V | V | |

Inverter Section Electrical Characteristics @T_J= 25°C

| Symbol | Parameter | Min | Typ | Max | Units | Conditions |
|-----------------------------------|---|-----|------|------|-------|--|
| V _{(BR)CES} | Collector-to-Emitter Breakdown Voltage | 600 | --- | --- | V | V _{IN} =5V, I _C =250μA |
| ΔV _{(BR)CES} / ΔT | Temperature Coeff. Of Breakdown Voltage | --- | 0.3 | --- | V/°C | V _{IN} =5V, I _C =1.0mA (25°C - 150°C) |
| V _{CE(ON)} | Collector-to-Emitter Saturation Voltage | --- | 1.55 | 1.85 | V | I _C =8A, V _{CC} =15V |
| | | --- | 1.80 | 2.10 | | I _C =8A, V _{CC} =15V, T _J =150°C |
| I _{CES} | Zero Gate Voltage Collector Current | --- | 5 | 80 | μA | V _{IN} =5V, V ⁺ =600V |
| | | --- | 165 | --- | | V _{IN} =5V, V ⁺ =600V, T _J =150°C |
| V _{FM} | Diode Forward Voltage Drop | --- | 2.0 | 2.4 | V | I _C =8A |
| | | --- | 1.4 | 1.9 | | I _C =8A, T _J =150°C |
| V _{BDFM} | Bootstrap Diode Forward Voltage Drop | -- | -- | 1.25 | V | I _F =1A |
| | | --- | --- | 1.10 | | I _F =1A, T _J =125°C |
| R _{BR} | Bootstrap Resistor Value | --- | 22 | --- | Ω | T _J =25°C |
| ΔR _{BR} /R _{BR} | Bootstrap Resistor Tolerance | --- | --- | ±5 | % | T _J =25°C |
| I _{BUS_TRIP} | Current Protection Threshold (positive going) | 21 | --- | 28 | A | T _J =-40°C to 125°C See Fig. 2 |

Inverter Section Switching Characteristics @ $T_J = 25^\circ\text{C}$

| Symbol | Parameter | Min | Typ | Max | Units | Conditions |
|-----------|-----------------------------------|-------------|-----|------|---------------|--|
| E_{ON} | Turn-On Switching Loss | --- | 315 | 435 | μJ | $I_C=8\text{A}$, $V^+=400\text{V}$ $V_{CC}=15\text{V}$, $L=2\text{mH}$ Energy losses include "tail" and diode reverse recovery |
| E_{OFF} | Turn-Off Switching Loss | --- | 150 | 180 | | |
| E_{TOT} | Total Switching Loss | --- | 465 | 615 | | |
| E_{REC} | Diode Reverse Recovery energy | --- | 30 | 60 | | |
| t_{RR} | Diode Reverse Recovery time | --- | 70 | 90 | ns | See CT1 |
| E_{ON} | Turn-on Switching Loss | --- | 500 | 700 | μJ | $I_C=8\text{A}$, $V^+=400\text{V}$ $V_{CC}=15\text{V}$, $L=2\text{mH}$, $T_J=150^\circ\text{C}$ Energy losses include "tail" and diode reverse recovery |
| E_{OFF} | Turn-off Switching Loss | --- | 270 | 335 | | |
| E_{TOT} | Total Switching Loss | --- | 770 | 1035 | | |
| E_{REC} | Diode Reverse Recovery energy | --- | 60 | 100 | | |
| t_{RR} | Diode Reverse Recovery time | --- | 120 | 150 | ns | See CT1 |
| Q_G | Turn-On IGBT Gate Charge | --- | 56 | 84 | nC | $I_C=15\text{A}$, $V^+=400\text{V}$, $V_{GE}=15\text{V}$ |
| RBSOA | Reverse Bias Safe Operating Area | FULL SQUARE | | | | $T_J=150^\circ\text{C}$, $I_C=8\text{A}$, $V_P=600\text{V}$ $V^+=450\text{V}$ $V_{CC}=+15\text{V}$ to 0V See CT3 |
| SCSOA | Short Circuit Safe Operating Area | 10 | --- | --- | μs | $T_J=150^\circ\text{C}$, $V_P=600\text{V}$, $V^+=360\text{V}$, $V_{CC}=+15\text{V}$ to 0V See CT2 |
| I_{CSC} | Short Circuit Collector Current | --- | 140 | --- | A | $T_J=150^\circ\text{C}$, $V_P=600\text{V}$, $t_{SC}<10\mu\text{s}$ $V^+=360\text{V}$, $V_{GE}=15\text{V}$ $V_{CC}=+15\text{V}$ to 0V See CT2 |

Recommended Operating Conditions Driver Function

The Input/Output logic timing diagram is shown in Figure 1. For proper operation the device should be used within the recommended conditions. All voltages are absolute referenced to COM/ I_{TRIP} . The V_S offset is tested with all supplies biased at 15V differential (Note 3)

| Symbol | Definition | Min | Max | Units |
|--------------|--|----------|------------|-------|
| $V_{B1,2,3}$ | High side floating supply voltage | V_S+12 | V_S+20 | V |
| $V_{S1,2,3}$ | High side floating supply offset voltage | Note 4 | 450 | |
| V_{CC} | Low side and logic fixed supply voltage | 12 | 20 | V |
| V_{ITRIP} | I_{TRIP} input voltage | V_{SS} | $V_{SS}+5$ | |
| V_{IN} | Logic input voltage LIN, HIN | V_{SS} | $V_{SS}+4$ | V |
| V_{EN} | Logic input voltage EN | V_{SS} | $V_{SS}+5$ | V |

Note 3: For more details, see IR21363 data sheet

Note 4: Logic operational for V_S from COM-5V to COM+600V. Logic state held for V_S from COM-5V to COM- V_{BS} . (please refer to DT97-3 for more details)

Static Electrical Characteristics Driver Function

V_{BIAS} (V_{CC} , $V_{BS1,2,3}$)=15V, unless otherwise specified. The V_{IN} and I_{IN} parameters are referenced to COM/ I_{TRIP} and are applicable to all six channels. (Note 3)

| Symbol | Definition | Min | Typ | Max | Units |
|---------------------------|--|------|------|------|---------|
| V_{INH} , V_{ENH} | Logic "0" input voltage | 3.0 | --- | --- | V |
| V_{INL} , V_{ENL} | Logic "1" input voltage | --- | --- | 0.8 | V |
| V_{CCUV+} , V_{BSUV+} | V_{CC} and V_{BS} supply undervoltage Positive going threshold | 10.6 | 11.1 | 11.6 | V |
| V_{CCUV-} , V_{BSUV-} | V_{CC} and V_{BS} supply undervoltage Negative going threshold | 10.4 | 10.9 | 11.4 | V |
| V_{CCUVH} , V_{BSUVH} | V_{CC} and V_{BS} supply undervoltage lock-out hysteresis | --- | 0.2 | --- | V |
| $V_{IN,Clamp}$ | Input Clamp Voltage (HIN, LIN, I_{TRIP}) $I_{IN}=10\mu A$ | 4.9 | 5.2 | 5.5 | V |
| I_{QBS} | Quiescent V_{BS} supply current $V_{IN}=0V$ | --- | --- | 165 | μA |
| I_{QCC} | Quiescent V_{CC} supply current $V_{IN}=0V$ | --- | --- | 3.35 | mA |
| I_{LK} | Offset Supply Leakage Current | --- | --- | 60 | μA |
| I_{IN+} , I_{EN+} | Input bias current $V_{IN}=5V$ | --- | 200 | 300 | μA |
| I_{IN-} , I_{EN-} | Input bias current $V_{IN}=0V$ | --- | 100 | 220 | μA |
| I_{TRIP+} | I_{TRIP} bias current $V_{ITRIP}=5V$ | --- | 30 | 100 | μA |
| I_{TRIP-} | I_{TRIP} bias current $V_{ITRIP}=0V$ | --- | 0 | 1 | μA |
| $V(I_{TRIP})$ | I_{TRIP} threshold Voltage | 440 | 490 | 540 | mV |
| $V(I_{TRIP}, HYS)$ | I_{TRIP} Input Hysteresis | --- | 70 | --- | mV |
| $R_{ON,FLT}$ | Fault Output ON Resistance | --- | 50 | 100 | ohm |

Dynamic Electrical Characteristics

Driver only timing unless otherwise specified.

| Symbol | Parameter | Min | Typ | Max | Units | Conditions |
|----------------|---|-----|-----|------|---------|---|
| T_{ON} | Input to Output propagation turn-on delay time (see fig.11) | --- | 590 | --- | ns | $V_{CC}=V_{BS}= 15V$, $I_C=8A$, $V^+=400V$ |
| T_{OFF} | Input to Output propagation turn-off delay time (see fig. 11) | --- | 660 | --- | ns | |
| T_{FLIN} | Input Filter time (HIN, LIN) | 100 | 200 | --- | ns | $V_{IN}=0$ & $V_{IN}=5V$ |
| $T_{BLT-Trip}$ | I_{TRIP} Blanking Time | 100 | 150 | --- | ns | $V_{IN}=0$ & $V_{IN}=5V$ |
| D_T | Dead Time ($V_{BS}=V_{DD}=15V$) | 220 | 290 | 360 | ns | $V_{BS}=V_{CC}=15V$ |
| M_T | Matching Propagation Delay Time (On & Off) | --- | 40 | 75 | ns | $V_{CC}= V_{BS}= 15V$, external dead time> 400ns |
| T_{ITrip} | I_{Trip} to six switch to turn-off propagation delay (see fig. 2) | --- | --- | 1.75 | μs | $V_{CC}=V_{BS}= 15V$, $I_C=8A$, $V^+=400V$ |
| $T_{FLT-CLR}$ | Post I_{Trip} to six switch to turn-off clear time (see fig. 2) | --- | 7.7 | --- | ms | $T_C = 25^\circ C$ |
| | | --- | 6.7 | --- | | $T_C = 100^\circ C$ |

IRAMX16UP60B

Thermal and Mechanical Characteristics

| Symbol | Parameter | Min | Typ | Max | Units | Conditions |
|---------------|-------------------------------|-----|-----|-----|-------|---|
| $R_{th(J-C)}$ | Thermal resistance, per IGBT | --- | 3.5 | 4.0 | °C/W | Flat, greased surface. Heatsink compound thermal conductivity 1W/mK |
| $R_{th(J-C)}$ | Thermal resistance, per Diode | --- | 5.0 | 5.5 | | |
| $R_{th(C-S)}$ | Thermal resistance, C-S | --- | 0.1 | --- | | |
| C_D | Creepage Distance | 3.2 | --- | --- | mm | See outline Drawings |

Internal Current Sensing Resistor - Shunt Characteristics

| Symbol | Parameter | Min | Typ | Max | Units | Conditions |
|-------------|-------------------------|------|------|------|--------|---|
| R_{Shunt} | Resistance | 17.9 | 18.1 | 18.3 | mΩ | $T_C = 25^\circ\text{C}$ |
| T_{Coeff} | Temperature Coefficient | 0 | --- | 200 | ppm/°C | |
| P_{Shunt} | Power Dissipation | --- | --- | 3.0 | W | $-40^\circ\text{C} < T_C < 100^\circ\text{C}$ |
| T_{Range} | Temperature Range | -40 | --- | 125 | °C | |

Internal NTC - Thermistor Characteristics

| Parameter | Definition | Min | Typ | Max | Units | Conditions |
|---------------------------|----------------------|------|------|------|-------|------------------------------------|
| R_{25} | Resistance | 97 | 100 | 103 | kΩ | $T_C = 25^\circ\text{C}$ |
| R_{125} | Resistance | 2.25 | 2.52 | 2.80 | kΩ | $T_C = 125^\circ\text{C}$ |
| B | B-constant (25-50°C) | 4165 | 4250 | 4335 | k | $R_2 = R_1 e^{[B(1/T_2 - 1/T_1)]}$ |
| Temperature Range | | -40 | | 125 | °C | |
| Typ. Dissipation constant | | | 1 | | mW/°C | $T_C = 25^\circ\text{C}$ |

Input-Output Logic Level Table

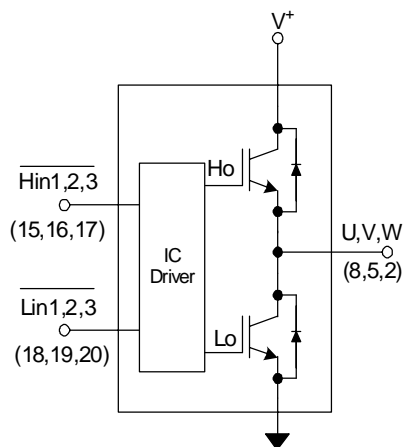

| FLT- EN | I_{TRIP} | $\overline{HIN1,2,3}$ | $\overline{LIN1,2,3}$ | U,V,W |
|---------|------------|-----------------------|-----------------------|-------|
| 1 | 0 | 0 | 1 | V^+ |
| 1 | 0 | 1 | 0 | 0 |
| 1 | 0 | 1 | 1 | Off |
| 1 | 1 | X | X | Off |
| 0 | X | X | X | Off |

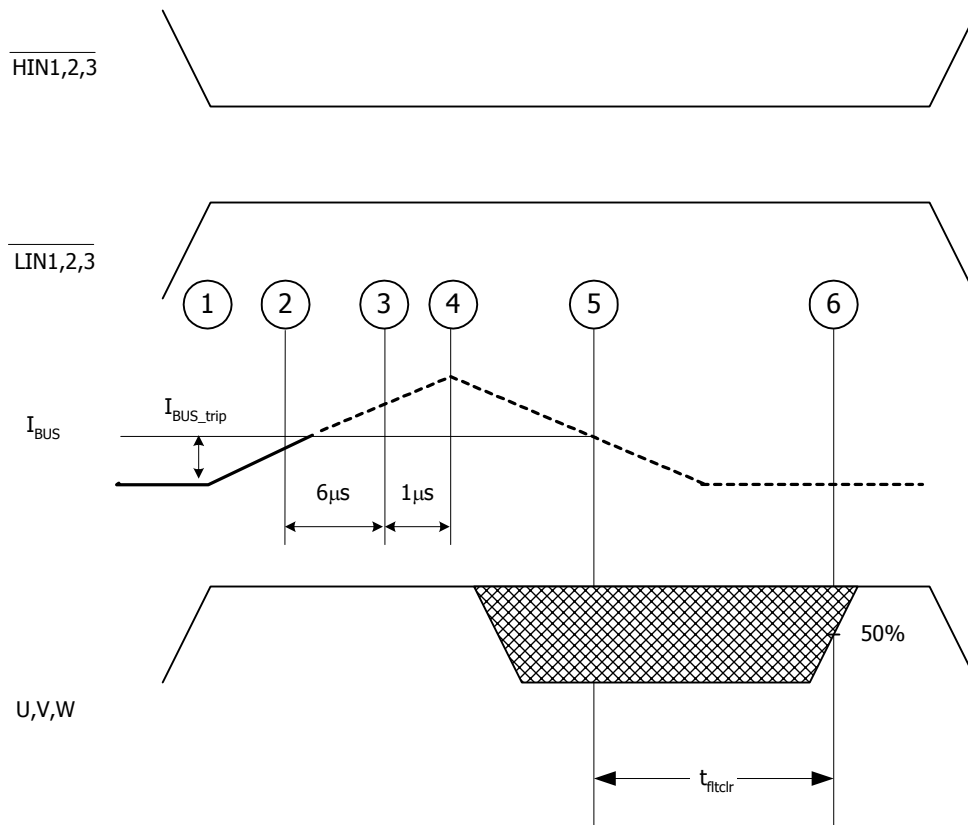

Sequence of events:

- 1-2) Current begins to rise
- 2) Current reaches I_{BUS_Trip} level
- 2-3) Current is higher than I_{BUS_Trip} for at least $6\mu s$. This value is the worst-case condition with very low over-current. In case of high current (short circuit), the actual delay will be smaller.
- 3-4) Delay between driver identification of over-current condition and disabling of all outputs
- 4) Current starts decreasing, eventually reaching 0
- 5) Current goes below I_{BUS_trip} , the driver starts its auto-reset sequence
- 6) Driver is automatically reset and normal operation can resume (over-current condition must be removed by the time the drivers automatically resets itself)

Figure 2. I_{Trip} Timing Waveform

Note 5: The shaded area indicates that both high-side and low-side switches are off and therefore the half-bridge output voltage would be determined by the direction of current flow in the load.

IRAMX16UP60B

Module Pin-Out Description

| Pin | Name | Description |
|-----|----------------------|---|
| 1 | V_{B3} | High Side Floating Supply Voltage 3 |
| 2 | W, V_{S3} | Output 3 - High Side Floating Supply Offset Voltage |
| 3 | NA | none |
| 4 | V_{B2} | High Side Floating Supply voltage 2 |
| 5 | V, V_{S2} | Output 2 - High Side Floating Supply Offset Voltage |
| 6 | NA | none |
| 7 | V_{B1} | High Side Floating Supply voltage 1 |
| 8 | U, V_{S1} | Output 1 - High Side Floating Supply Offset Voltage |
| 9 | NA | none |
| 10 | V^+ | Positive Bus Input Voltage |
| 11 | NA | none |
| 12 | V^- | Negative Bus Input Voltage |
| 13 | V_{TH} | Temperature Feedback |
| 14 | V_{CC} | +15V Main Supply |
| 15 | $\overline{H_{IN1}}$ | Logic Input High Side Gate Driver - Phase 1 |
| 16 | $\overline{H_{IN2}}$ | Logic Input High Side Gate Driver - Phase 2 |
| 17 | $\overline{H_{IN3}}$ | Logic Input High Side Gate Driver - Phase 3 |
| 18 | $\overline{L_{IN1}}$ | Logic Input Low Side Gate Driver - Phase 1 |
| 19 | $\overline{L_{IN2}}$ | Logic Input Low Side Gate Driver - Phase 2 |
| 20 | $\overline{L_{IN3}}$ | Logic Input Low Side Gate Driver - Phase 3 |
| 21 | FAULT | Fault Indicator |
| 22 | I_{TRIP} | Current Sense and Itrip Pin |
| 23 | V_{SS} | Negative Main Supply |



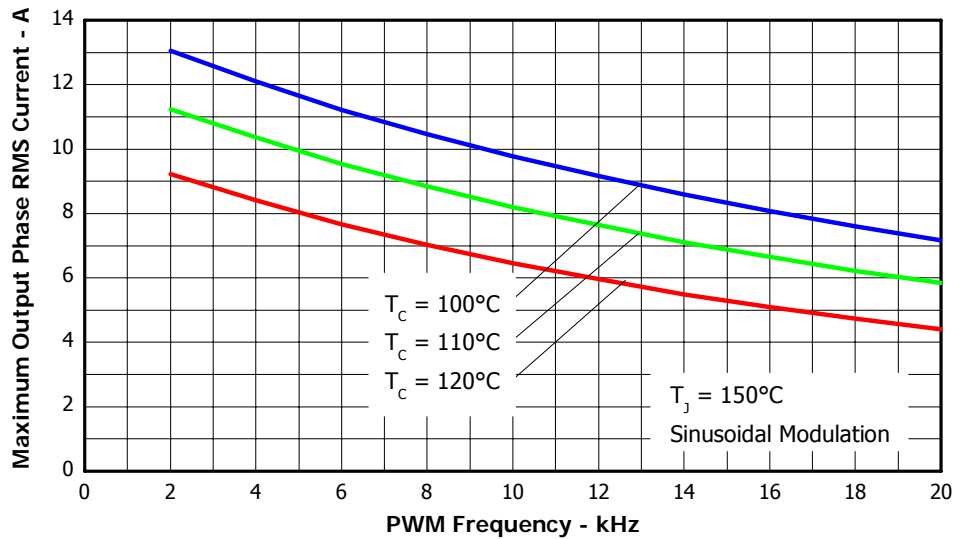

Figure 3. Maximum Sinusoidal Phase Current vs. PWM Switching Frequency
 $V^+ = 400\text{V}$, $T_j = 150^\circ\text{C}$, Modulation Depth=0.8, PF=0.6

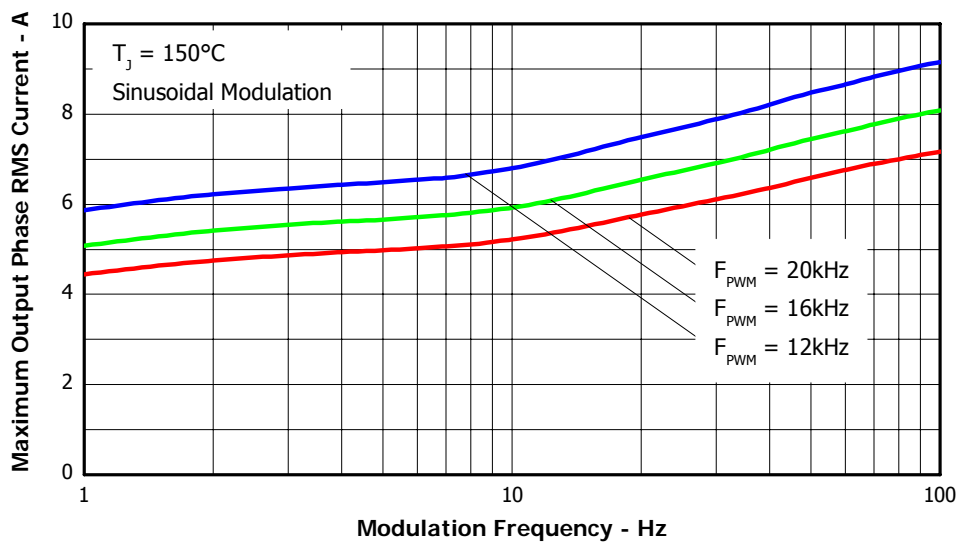

Figure 4. Maximum Sinusoidal Phase Current vs. Modulation Frequency
 $V^+ = 400\text{V}$, $T_j = 150^\circ\text{C}$, $T_c = 100^\circ\text{C}$, Modulation Depth=0.8, PF=0.6

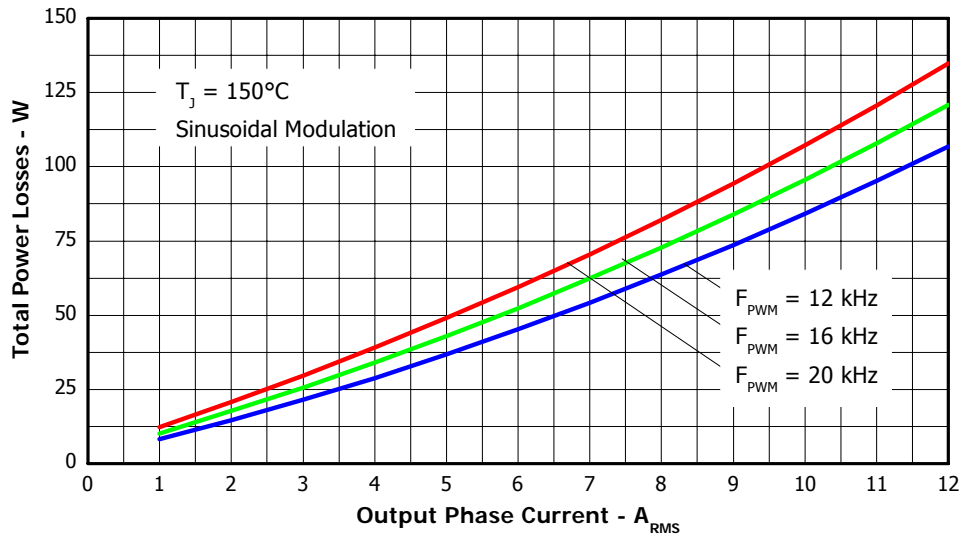

Figure 5. Total Power Losses vs. PWM Switching Frequency, Sinusoidal modulation
 $V^+=400V$, $T_j=150^\circ C$, Modulation Depth=0.8, PF=0.6

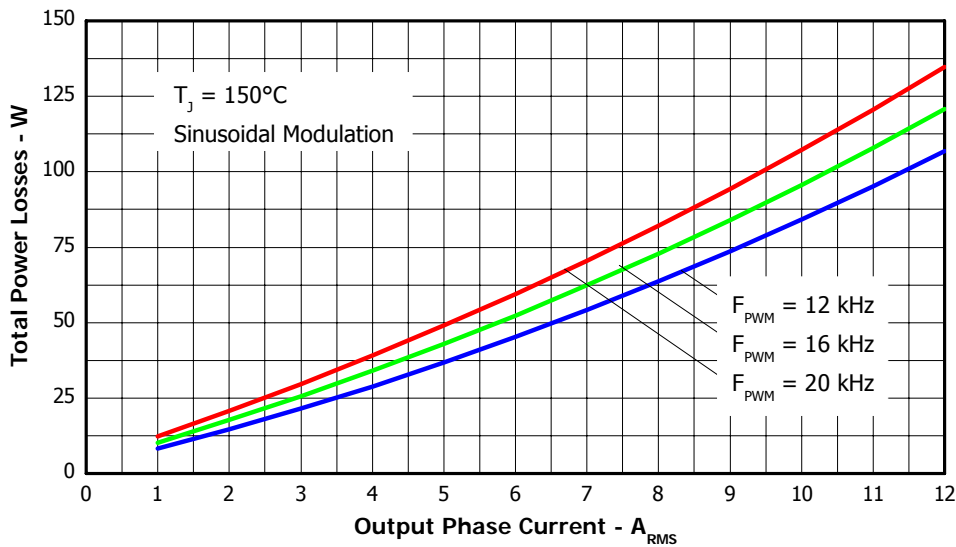

Figure 6. Total Power Losses vs. Output Phase Current, Sinusoidal modulation
 $V_{BUS}=400V$, $T_j=150^\circ C$, Modulation Depth=0.8, PF=0.6

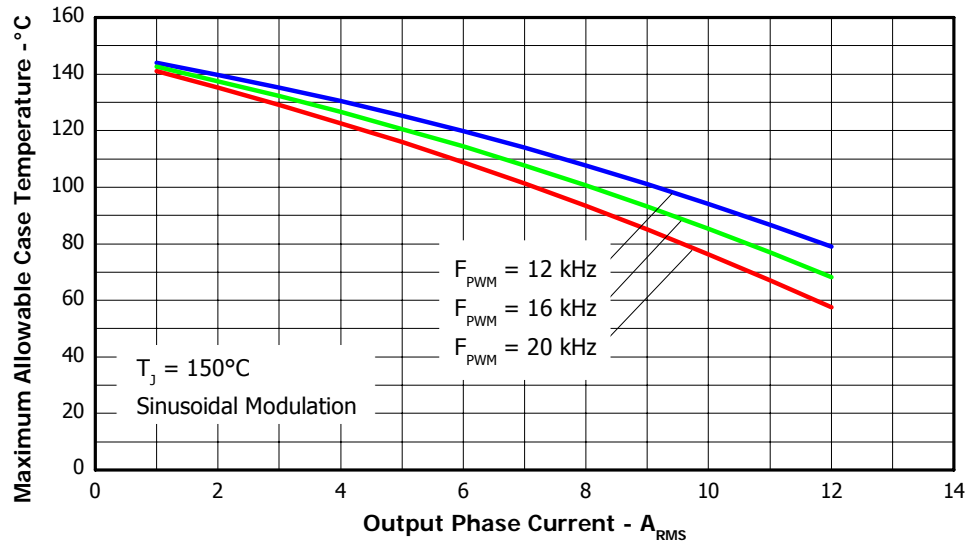

Figure 7. Maximum Allowable Case temperature vs. Output RMS Current per Phase

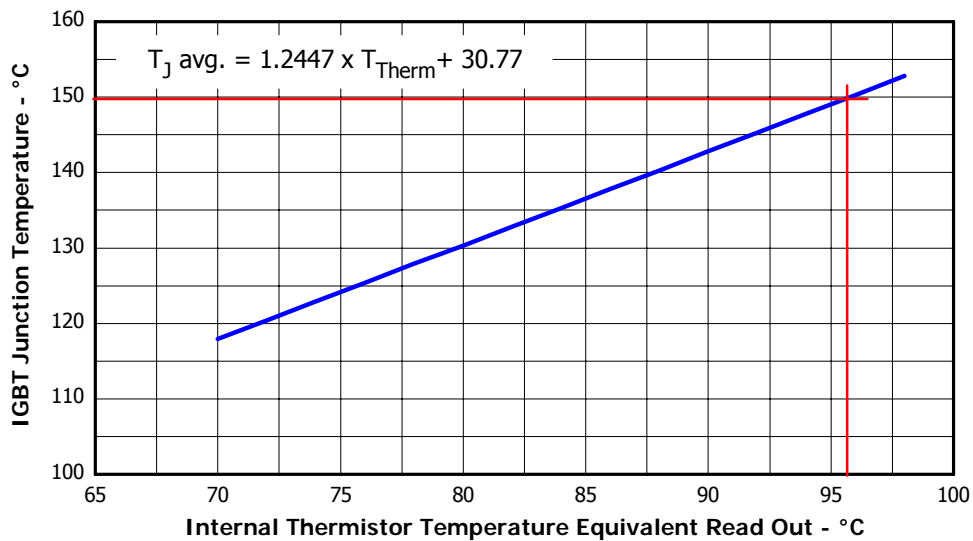

Figure 8. Estimated Maximum IGBT Junction Temperature vs. Thermistor Temperature

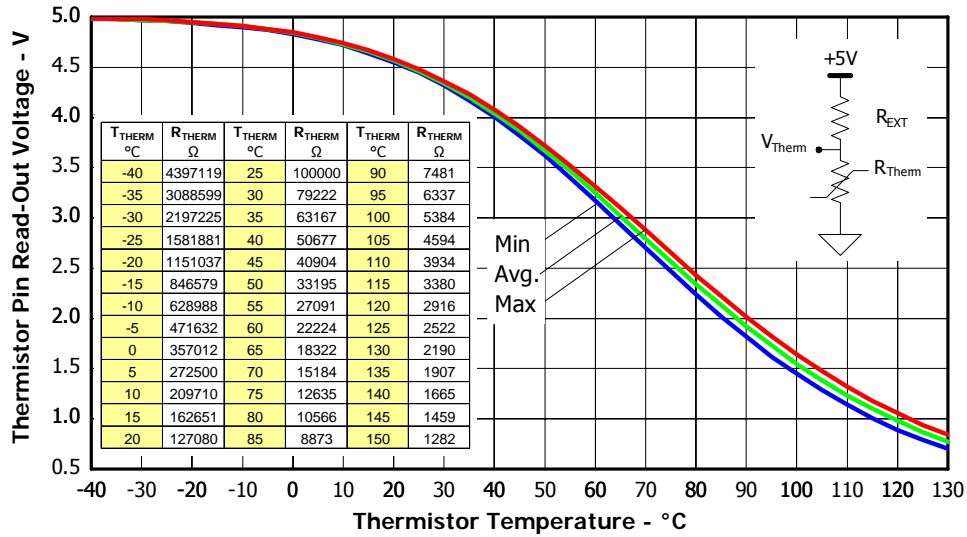

Figure 9. Thermistor Readout vs. Temperature (12kohm pull-up resistor, 5V) and Nominal Thermistor Resistance values vs. Temperature Table.

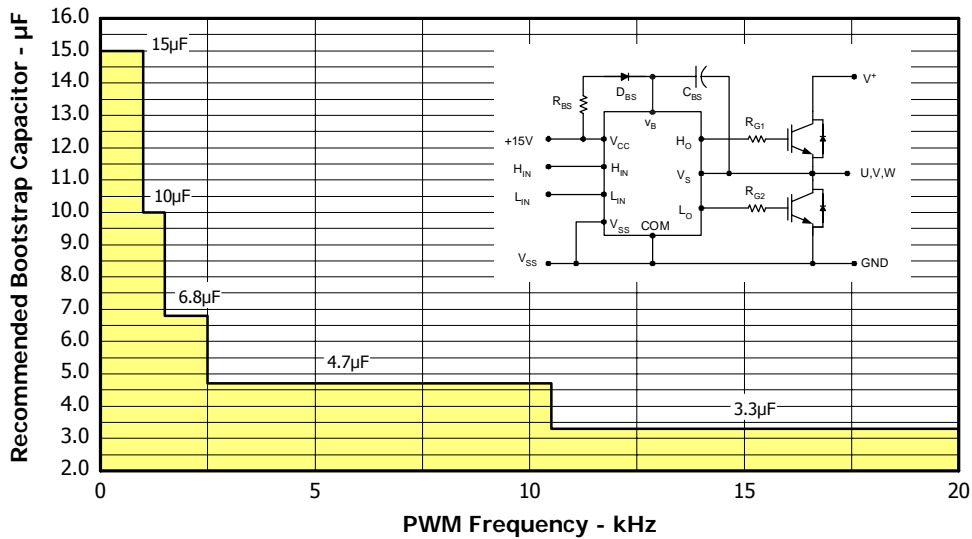

Figure 10. Recommended Bootstrap Capacitor Value vs. Switching Frequency

Figure 11. Switching Parameter Definitions

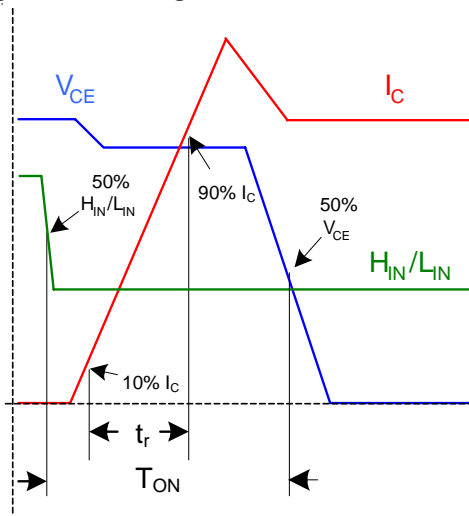

Figure 11a. Input to Output Propagation turn-on Delay Time

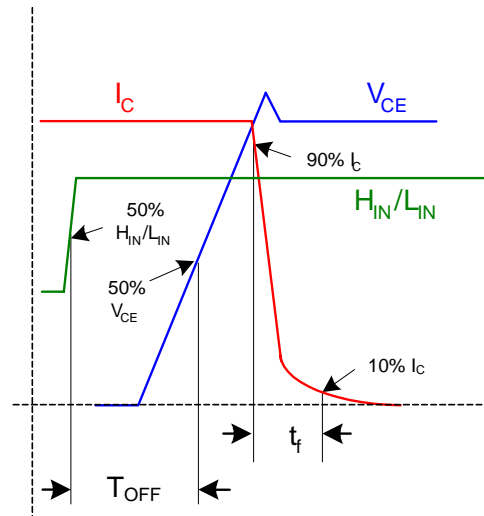

Figure 11b. Input to Output Propagation turn-off Delay Time

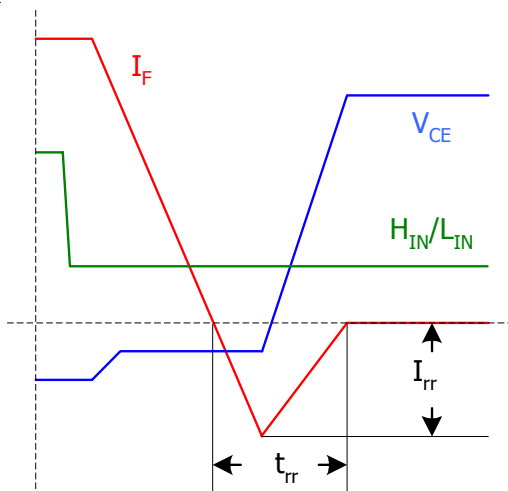

Figure 11c. Diode Reverse Recovery

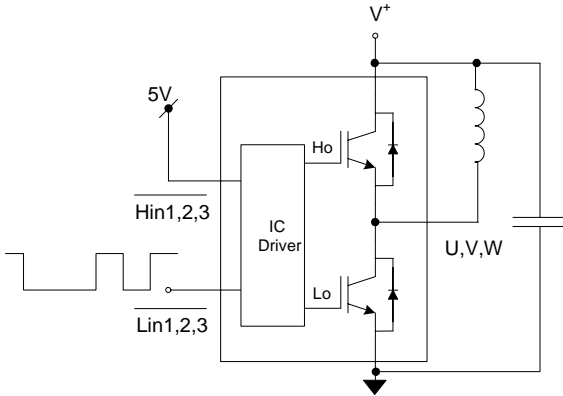

Figure CT1. Switching Loss Circuit

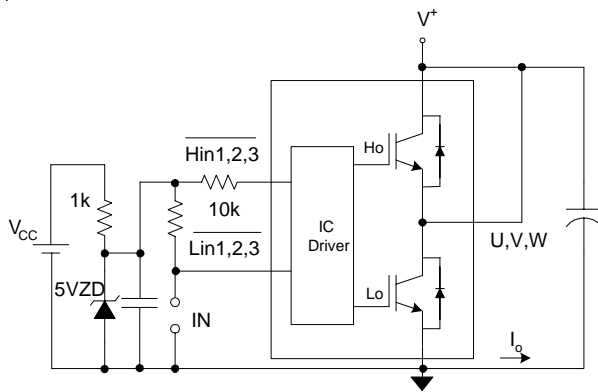

Figure CT2. S.C.SOA Circuit

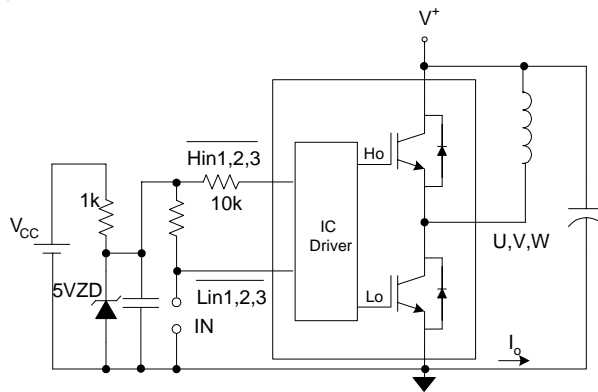
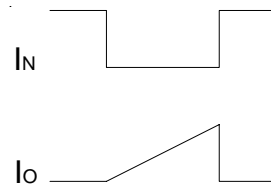
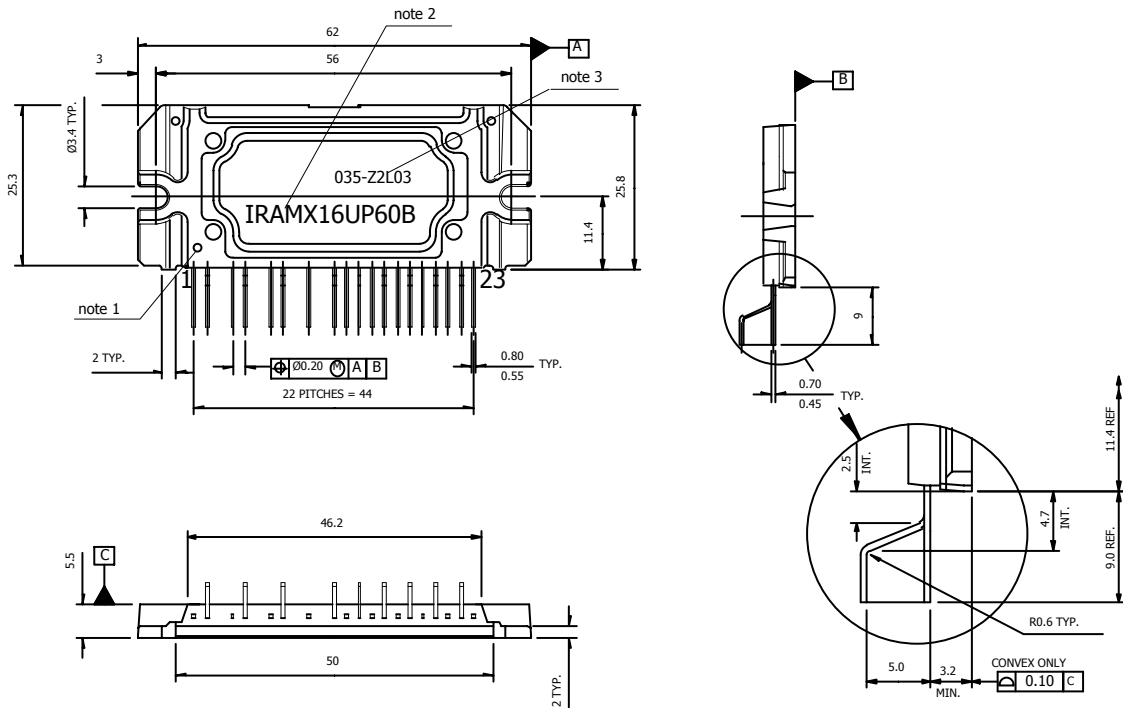

Figure CT3. R.B.SOA Circuit



IRAMX16UP60B

Package Outline IramX16UP60B



Notes:

Dimensions in mm

1- Marking for pin 1 identification

2- Product Part Number

3- Lot and Date code marking

4- Convex only 0.15mm typical

5- Tolerances ± 0.5 mm, unless otherwise stated

For mounting instruction see AN-1049

Package Outline IRAMX16UP60B-2

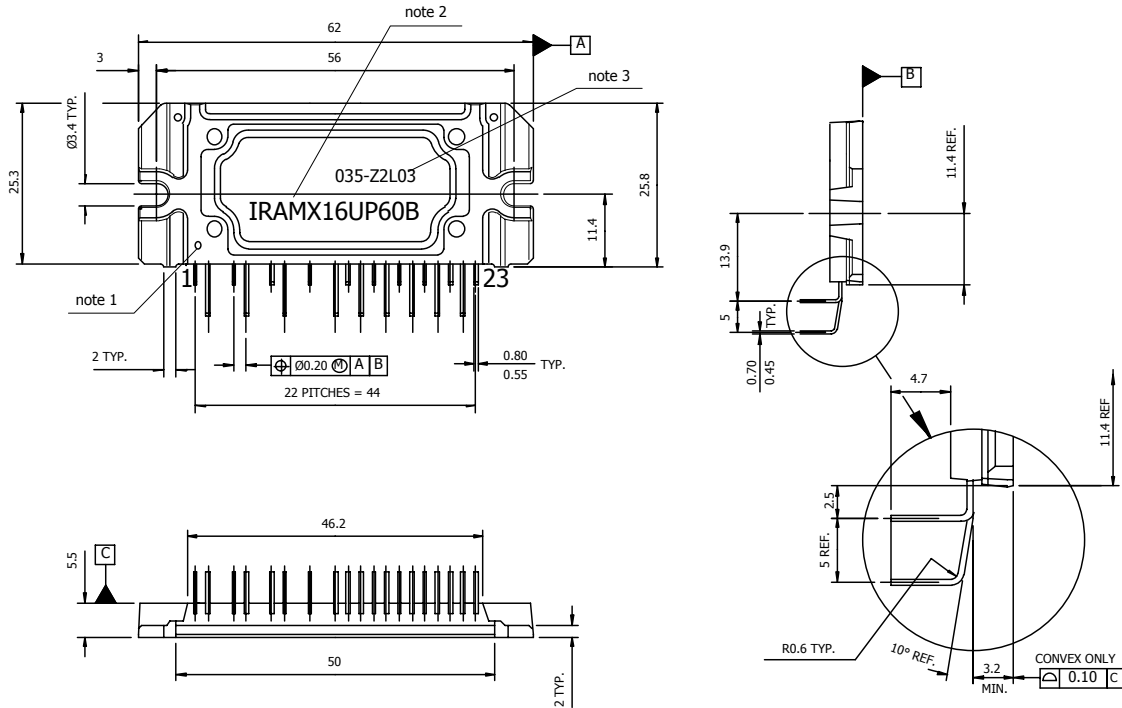

Notes:

Dimensions in mm

- 1- Marking for pin 1 identification
- 2- Product Part Number
- 3- Lot and Date code marking
- 4- Convex only 0.15mm typical
- 5- Tolerances ± 0.5 mm, unless otherwise stated

For mounting instruction see AN-1049