

### Intellimod™ Module Dual-In-Line Intelligent Power Module 8 Amperes/600 Volts

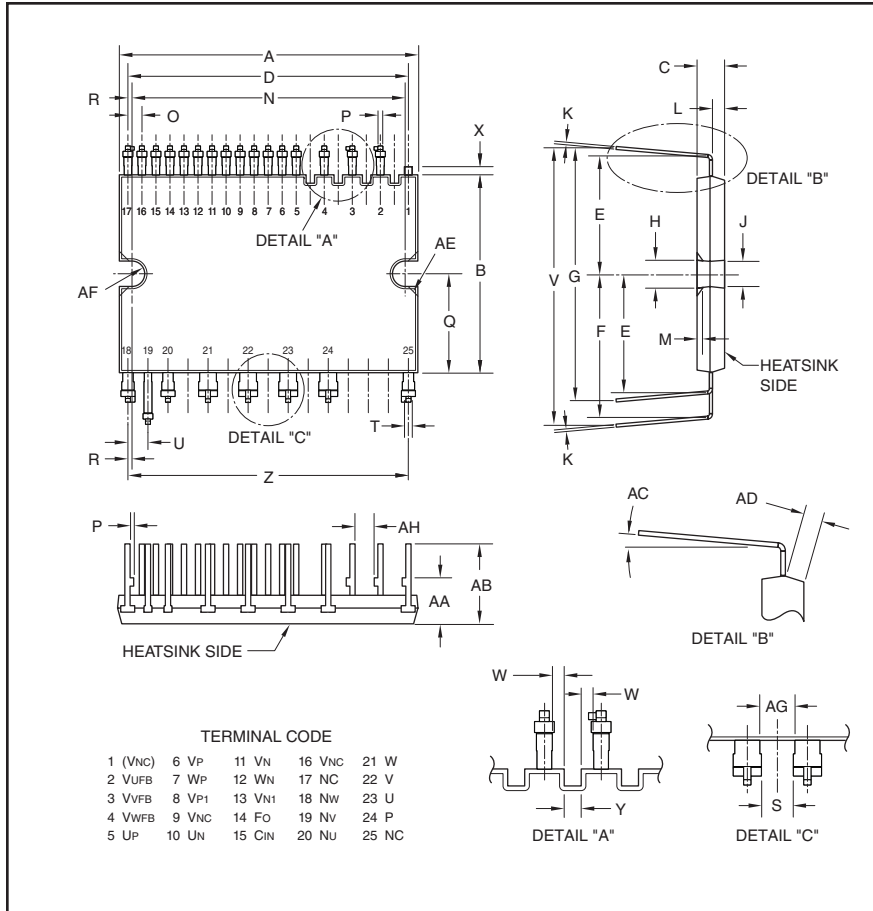

#### Outline Drawing and Circuit Diagram

Dimensions	Inches	Millimeters
A	1.50±0.02	38.0±0.5
B	0.94±0.02	24.0±0.5
C	0.14	3.5
D	1.40	35.56
E	0.57±0.02	14.4±0.5
F	0.74±0.02	18.9±0.5
G	1.15±0.02	29.2±0.5
H	0.14	3.5
J	0.13	3.3
K	0.016	0.4
L	0.06±0.02	1.5±0.05
M	0.031	0.8
N	1.39±0.019	35.0±0.3
O	0.07±0.008	1.778±0.2
P	0.02	0.5
Q	0.47	12.0
R	0.011	0.28

Dimensions	Inches	Millimeters
S	0.12	2.8
T	0.024	0.6
U	0.1±0.008	2.54±0.2
V	1.33±0.02	33.7±0.5
W	0.03	0.678
X	0.04	1.0
Y	0.05	1.2
Z	1.40	35.56
AA	0.22±0.02	5.5±0.5
AB	0.37±0.02	9.5±0.5
AC	0 ~ 5°	0 ~ 5°
AD	0.06 Min.	1.5 Min.
AE	0.05	1.2
AF	0.063 Rad.	1.6 Rad.
AG	0.118 Min.	3.0 Min.
AH	0.098 Min.	2.5 Min.

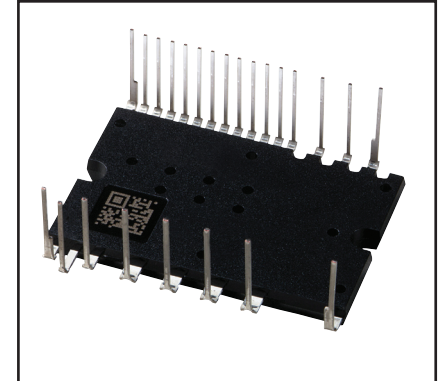

#### Description:

DIP-IPMs are intelligent power modules that integrate power devices, drivers, and protection circuitry in an ultra compact dual-in-line transfer-mold package for use in driving small three phase motors. Use of 5th generation IGBTs, DIP packaging, and application specific HVICs allow the designer to reduce inverter size and overall design time.

#### Features:

- Compact Packages
- Single Power Supply
- Integrated HVICs
- Direct Connection to CPU
- Reduced  $R_{th}$

#### Applications:

- Refrigerators
- Air Conditioners
- Small Servo Motors
- Small Motor Control

#### Ordering Information:

PS21963-4ES is a 600V, 8 Ampere short pin DIP Intelligent Power Module.

**PS21963-4ES**  
**Intellimod™ Module**  
**Dual-In-Line Intelligent Power Module**  
 8 Amperes/600 Volts

## Absolute Maximum Ratings, $T_j = 25^\circ\text{C}$ unless otherwise specified

Characteristics	Symbol	PS21963-4ES	Units
Power Device Junction Temperature*	$T_j$	-20 to 150	$^\circ\text{C}$
Storage Temperature	$T_{\text{stg}}$	-40 to 125	$^\circ\text{C}$
Case Operating Temperature (Note 1)	$T_C$	-20 to 100	$^\circ\text{C}$
Mounting Torque, M3 Mounting Screws	—	6.9	in-lb
Module Weight (Typical)	—	10	Grams
Heatsink Flatness (Note 2)	—	-50 to 100	$\mu\text{m}$
Self-protection Supply Voltage Limit (Short Circuit Protection Capability)**	$V_{\text{CC(prot.)}}$	400	Volts
Isolation Voltage, AC 1 minute, 60Hz Sinusoidal, Connection Pins to Heatsink Plate	$V_{\text{ISO}}$	1500	Volts

\*The maximum junction temperature rating of the power chips integrated within the DIP-IPM is  $150^\circ\text{C}$  ( $@T_C \leq 100^\circ\text{C}$ ). However, to ensure safe operation of the DIP-IPM, the average junction temperature should be limited to  $T_{j(\text{avg})} \leq 125^\circ\text{C}$  ( $@T_C \leq 100^\circ\text{C}$ ).

\*\* $V_D = 13.5 \sim 16.5\text{V}$ , Inverter Part,  $T_j = 125^\circ\text{C}$ , Non-repetitive, Less than  $2\mu\text{s}$

## IGBT Inverter Sector

Collector-Emitter Voltage	$V_{\text{CES}}$	600	Volts
Each Collector Current, $\pm$ ( $T_C = 25^\circ\text{C}$ )	$I_C$	8	Amperes
Each Peak Collector Current, $\pm$ ( $T_C = 25^\circ\text{C}$ , Less than 1ms)	$I_{\text{CP}}$	16	Amperes
Supply Voltage (Applied between P - N)	$V_{\text{CC}}$	450	Volts
Supply Voltage, Surge (Applied between P - N)	$V_{\text{CC(surge)}}$	500	Volts
Collector Dissipation ( $T_C = 25^\circ\text{C}$ , per 1 Chip)	$P_C$	24.3	Watts

## Control Sector

Supply Voltage (Applied between $V_{P1-V_{NC}}$ , $V_{N1-V_{NC}}$ )	$V_D$	20	Volts
Supply Voltage (Applied between $V_{UFB-U}$ , $V_{VFB-V}$ , $V_{WFB-W}$ )	$V_{\text{DB}}$	20	Volts
Input Voltage (Applied between $U_P$ , $V_P$ , $W_P-V_{NC}$ , $U_N$ , $V_N$ , $W_N-V_{NC}$ )	$V_{\text{IN}}$	$-0.5 \sim V_D + 0.5$	Volts
Fault Output Supply Voltage (Applied between $F_O-V_{NC}$ )	$V_{\text{FO}}$	$-0.5 \sim V_D + 0.5$	Volts
Fault Output Current (Sink Current at $F_O$ Terminal)	$I_{\text{FO}}$	1	mA
Current Sensing Input Voltage (Applied between $C_{\text{IN}}-V_{NC}$ )	$V_{\text{SC}}$	$-0.5 \sim V_D + 0.5$	Volts

Note 1 –  $T_C$  Measure Point

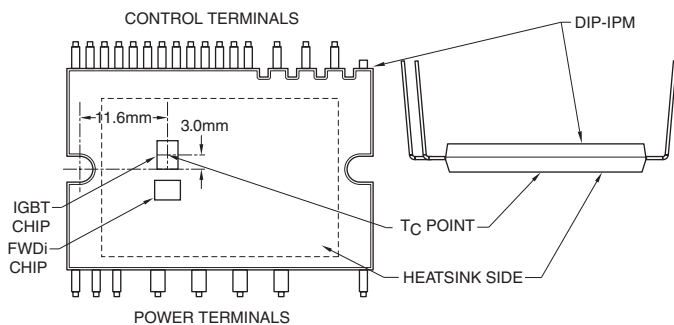

Note 2 – Flatness Measurement Position

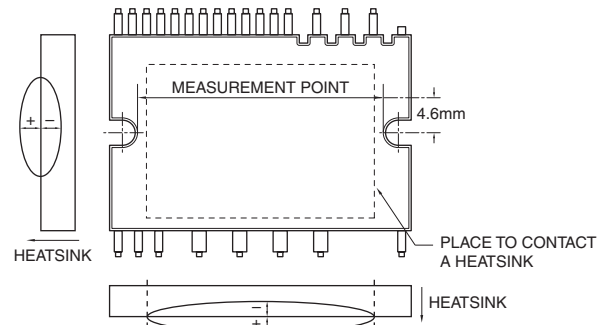

PS21963-4ES  
 Intellimod™ Module  
 Dual-In-Line Intelligent Power Module  
 8 Amperes/600 Volts

## Electrical and Mechanical Characteristics, $T_j = 25^\circ\text{C}$ unless otherwise specified

Characteristics	Symbol	Test Conditions	Min.	Typ.	Max.	Units
<b>IGBT Inverter Sector</b>						
Collector-Emitter Saturation Voltage	$V_{CE(sat)}$	$V_D = V_{DB} = 15\text{V}, I_C = 8\text{A}, V_{IN} = 5\text{V}, T_j = 25^\circ\text{C}$	—	1.70	2.20	Volts
		$V_D = V_{DB} = 15\text{V}, I_C = 8\text{A}, V_{IN} = 5\text{V}, T_j = 125^\circ\text{C}$	—	1.80	2.30	Volts
Diode Forward Voltage	$V_{EC}$	$-I_C = 8\text{A}, V_{IN} = 0\text{V}$	—	1.90	2.35	Volts
Inductive Load Switching Times	$t_{on}$		0.60	1.10	1.70	$\mu\text{s}$
	$t_{rr}$	$V_{CC} = 300\text{V}, V_D = V_{DB} = 15\text{V},$	—	0.30	—	$\mu\text{s}$
	$t_{C(on)}$	$I_C = 8\text{A}, T_j = 125^\circ\text{C},$	—	0.40	0.60	$\mu\text{s}$
	$t_{off}$	$V_{IN} = 0 \leftrightarrow 5\text{V}, \text{Inductive Load},$	—	1.40	2.00	$\mu\text{s}$
	$t_{C(off)}$		—	0.40	0.75	$\mu\text{s}$
Collector Cutoff Current	$I_{CES}$	$V_{CE} = V_{CES}, T_j = 25^\circ\text{C}$	—	—	1.0	mA
		$V_{CE} = V_{CES}, T_j = 125^\circ\text{C}$	—	—	10	mA

## Control Sector

Circuit Current	$I_D$	$V_{IN} = 5\text{V}$	Total of $V_{P1}-V_{NC}, V_{N1}-V_{NC}$	—	—	2.80	mA
			$V_{UFB-U}, V_{VFB-V}, V_{WFB-W}$	—	—	0.55	mA
		$V_{IN} = 0\text{V}$	Total of $V_{P1}-V_{NC}, V_{N1}-V_{NC}$	—	—	2.80	mA
			$V_{UFB-U}, V_{VFB-V}, V_{WFB-W}$	—	—	0.55	mA
Fault Output Voltage	$V_{FOH}$	$V_{SC} = 0\text{V}, F_O \text{ Terminal Pull-up to } 5\text{V by } 10\text{k}\Omega$	4.9	—	—	Volts	
	$V_{FOL}$	$V_{SC} = 1\text{V}, I_{FO} = 1\text{mA}$	—	—	0.95	Volts	
Input Current	$I_{IN}$	$V_{IN} = 5\text{V}$	0.70	1.00	1.50	mA	
Short Circuit Trip Level*	$V_{SC(ref)}$	$V_D = 15\text{V}^*$	0.43	0.48	0.53	Volts	
Supply Circuit Under-voltage	$UV_{DBt}$	Trip Level, $T_j \leq 125^\circ\text{C}$	10.0	—	12.0	Volts	
	$UV_{DBr}$	Reset Level, $T_j \leq 125^\circ\text{C}$	10.5	—	12.5	Volts	
	$UV_{Dt}$	Trip Level, $T_j \leq 125^\circ\text{C}$	10.3	—	12.5	Volts	
	$UV_{Dr}$	Reset Level, $T_j \leq 125^\circ\text{C}$	10.8	—	13.0	Volts	
Fault Output Pulse Width**	$t_{FO}$		20	—	—	$\mu\text{s}$	
ON Threshold Voltage	$V_{th(on)}$	Applied between	—	2.1	2.6	Volts	
OFF Threshold Voltage	$V_{th(off)}$	$U_P, V_P, W_P-V_{NC},$	0.8	1.3	—	Volts	
ON/OFF Threshold Hysteresis Voltage	$V_{th(hys)}$	$U_N, V_N, W_N-V_{NC}$	0.35	0.65	—	Volts	

\* Short Circuit protection is functioning only for the low-arms. Please select the value of the external shunt resistor such that the  $S_C$  trip level is less than 1.7 times the current rating.

\*\*Fault signal is asserted only for a  $U_V$  or  $S_C$  condition on the low side. On a  $S_C$  fault the  $F_O$  duration will be 20 $\mu\text{sec}$ . On a  $U_V$  condition the fault signal will be asserted as long as the  $U_V$  condition exists or for 20 $\mu\text{sec}$ , whichever is longer.

PS21963-4ES  
 Intellimod™ Module  
 Dual-In-Line Intelligent Power Module  
 8 Amperes/600 Volts

## Thermal Characteristics

Characteristic	Symbol	Condition	Min.	Typ.	Max.	Units
Junction to Case	$R_{th(j-c)Q}$	Inverter IGBT (Per 1/6 Module)	—	—	4.1	°C/Watt
	$R_{th(j-c)D}$	Inverter FWDi (Per 1/6 Module)	—	—	5.4	°C/Watt

## Recommended Conditions for Use

Characteristic	Symbol	Condition	Min.	Typ.	Max.	Units
Supply Voltage	$V_{CC}$	Applied between P-N Terminals	0	300	400	Volts
Control Supply Voltage	$V_D$	Applied between $V_{P1}$ - $V_{NC}$ , $V_{N1}$ - $V_{NC}$	13.5	15.0	16.5	Volts
	$V_{DB}$	Applied between $V_{UFB-U}$ , $V_{VFB-V}$ , $V_{WFB-W}$	13.0	15.0	18.5	Volts
Control Supply Variation	$dV_D$ , $dV_{DB}$		-1	—	1	V/ $\mu$ s
Arm Shoot-through Blocking Time	$t_{DEAD}$	For Each Input Signal, $T_C \leq 100^\circ\text{C}$	1.5	—	—	$\mu$ s
Allowable Minimum Input	$P_{WIN(on)}$		0.5	—	—	$\mu$ s
Pulse Width*	$P_{WIN(off)}$		0.5	—	—	$\mu$ s
$V_{NC}$ Voltage Variation	$V_{NC}$	Between $V_{NC-N}$ (Including Surge)	-5.0	—	5.0	Volts

\*DIP-IPM might not make response or work properly if the input signal pulse width is less than the recommended minimum value.

**PS21963-4ES**  
**Intellimod™ Module**  
**Dual-In-Line Intelligent Power Module**  
 8 Amperes/600 Volts

## Application Circuit

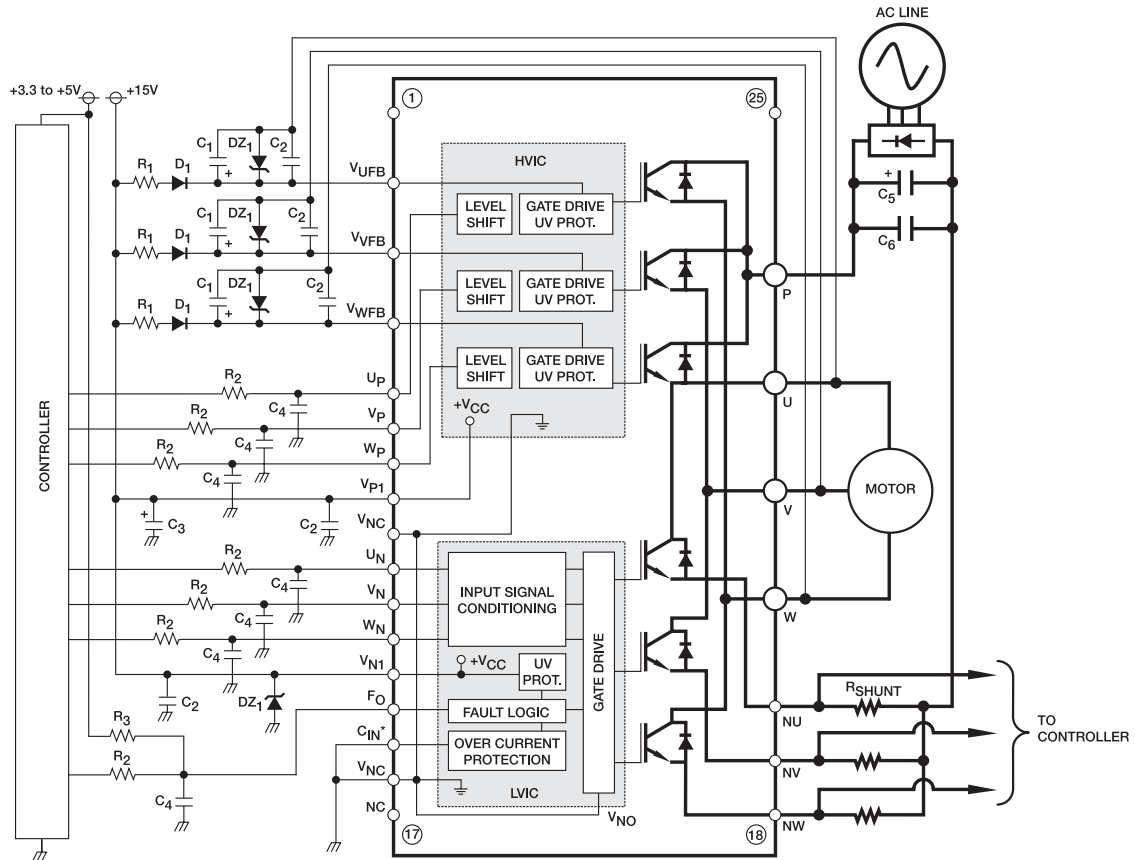

\*See Note 7

**Component Selection:**

Dsgn.	Typ. Value	Description
D1	1A, 600V	Boot strap supply diode – Ultra fast recovery
DZ1	24V, 1.0W	Control and boot strap supply over voltage suppression
C1	10-100uF, 50V	Boot strap supply reservoir – Electrolytic, long life, low Impedance, 105°C (Note 5)
C2	0.22-2.0uF, 50V	Local decoupling/High frequency noise filters – Multilayer ceramic (Note 8)
C3	10-100uF, 50V	Control power supply filter – Electrolytic, long life, low Impedance, 105°C
C4	100pF, 50V	Optional Input signal noise filter – Multilayer ceramic (Note 1)
C5	200-2000uF, 450V	Main DC bus filter capacitor – Electrolytic, long life, high ripple current, 105°C
C6	0.1-0.22uF, 450V	Surge voltage suppression capacitor – Polyester/Polypropylene film (Note 9)
RSHUNT	5-100mohm	Current sensing resistor – Non-inductive, temperature stable, tight tolerance (Note 10)
R1	10 ohm	Boot strap supply inrush limiting resistor (Note 5)
R2	330 ohm	Optional control input noise filter (Note 1, Note 2)
R3	10k ohm	Fault output signal pull-up resistor (Note 3)

**Notes:**

- To prevent input signal oscillations minimize wiring length to controller (~2cm). Additional RC filtering (C5 etc.) may be required. If filtering is added be careful to maintain proper dead time and voltage levels. See application notes for details.
- Internal HVIC provides high voltage level shifting allowing direct connection of all six driving signals to the controller.
- FO output is an open collector type. Pull up resistor (R3) should be adjusted to current sink capability of the controller.
- Use only one VNC Pin (either 9 or 16) and leave the other open.
- Boot strap supply component values must be adjusted depending on the PWM frequency and technique.
- Wiring length associated with RSHUNT, must be minimized to avoid improper operation of the OC function.
- Shows short circuit protection disabled. See application notes for use of short circuit protection.
- Local decoupling/high frequency filter capacitors must be connected as close as possible to the modules pins.
- The length of the DC link wiring between C5, C6, the DIP's P terminal and the shunt must be minimized to prevent excessive transient voltages. In particular C6 should be mounted as close to the DIP as possible.
- Use high quality, tight tolerance current sensing resistor. Connect resistor as close as possible to the DIP's N terminal. Be careful to check for proper power rating. See application notes for calculation of resistance value.

PS21963-4ES  
 Intellimod™ Module  
 Dual-In-Line Intelligent Power Module  
 8 Amperes/600 Volts

## Protection Function Timing Diagrams

Short-Circuit Protection (Lower-arms only with the external shunt resistor and CR filter)

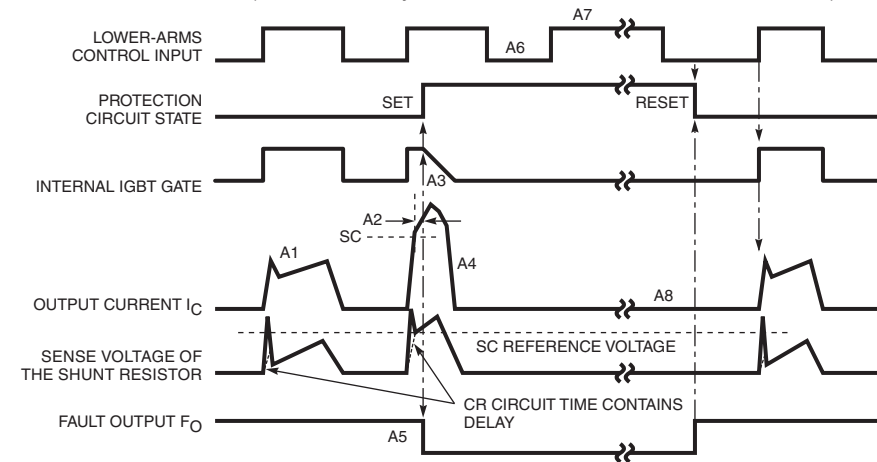

- A1: Normal operation – IGBT turn on and conducting current.
- A2: Short-circuit current detected (SC trigger).
- A3: IGBT gate hard interrupted.
- A4: IGBT turn off.
- A5:  $F_O$  output with a fixed pulse width of  $t_{FO(min)} = 20\mu s$ .
- A6: Input "L" – IGBT off.
- A7: Input "H" – IGBT on is blocked during the  $F_O$  output period.
- A8: IGBT stays in off state.

Under-Voltage Protection (Lower-side,  $UV_D$ )

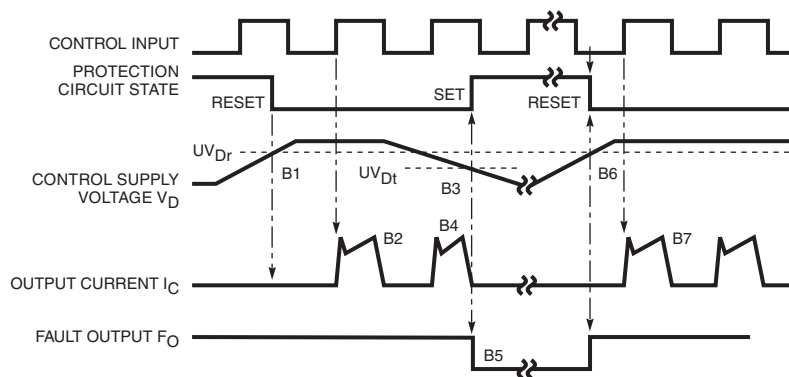

- B1: Control supply voltage rise – After the voltage level reaches  $UV_{Dr}$ , the drive circuit begins to work at the rising edge of the next input signal.
- B2: Normal operation – IGBT turn on and conducting current.
- B3: Under-voltage trip ( $UV_{Dt}$ ).
- B4: IGBT turn off regardless of the control input level.
- B5:  $F_O$  output during under-voltage period, however, the minimum pulse width is  $20\mu s$ .
- B6: Under-voltage reset ( $UV_{Dr}$ ).
- B7: Normal operation – IGBT turn on and conducting current.

PS21963-4ES  
 Intellimod™ Module  
 Dual-In-Line Intelligent Power Module  
 8 Amperes/600 Volts

## Protection Function Timing Diagrams

Under-Voltage Protection (Upper-side, UV<sub>DB</sub>)

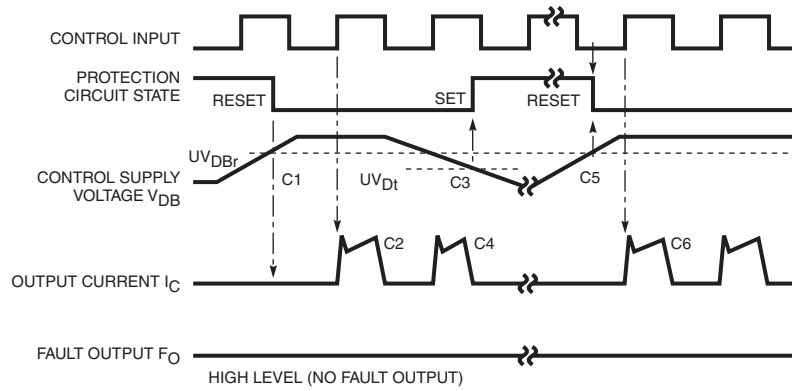

- C1: Control supply voltage rises – After the voltage level reaches UV<sub>DBr</sub>, the drive circuit begins to work at the rising edge of the next input signal.
- C2: Normal operation – IGBT turn on and conducting current.
- C3: Under-voltage trip (UV<sub>DBt</sub>).
- C4: IGBT stays off regardless of the control input level, but there is no F<sub>O</sub> signal output.
- C5: Under-voltage reset (UV<sub>Dt</sub>).
- C6: Normal operation – IGBT turn on and conducting current.

## Typical Interface Circuit

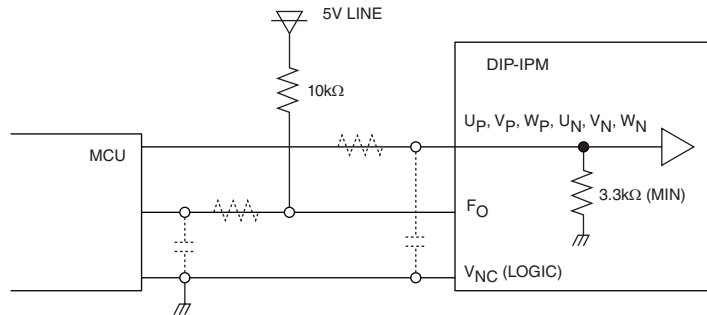

NOTE: RC coupling at each input (parts shown dotted) may change depending on the PWM control scheme used in the application and the wiring impedance of the printed circuit board. The DIP-IPM input signal section integrates a 3.3kΩ (min) pull-down resistor. Therefore, when using an external filtering resistor, care must be taken to satisfy the turn-on threshold voltage requirement.

## Wiring Method Around Shunt Resistor

