

Dual Power MOSFET Module

VMK 165-007T

$V_{DSS} = 70 \text{ V}$
 $I_{D25} = 165 \text{ A}$
 $R_{DS(on)} = 7 \text{ m}\Omega$

Common-Source connected
N-Channel Enhancement Mode

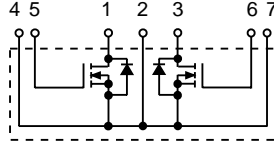

Symbol	Conditions	Maximum Ratings	
V_{DSS}	$T_J = 25^\circ\text{C}$ to 150°C	70	V
V_{DGR}	$T_J = 25^\circ\text{C}$ to 150°C ; $R_{GS} = 6.8 \text{ k}\Omega$	70	V
V_{GS}	Continuous	± 20	V
V_{GSM}	Transient	± 30	V
I_{D25}	$T_C = 25^\circ\text{C}$	165	A
I_D	$T_C = 100^\circ\text{C}$	104	A
I_{DM}	$T_C = 25^\circ\text{C}$, $t_p = 10 \mu\text{s}$, pulse width limited by T_{JM}	660	A
P_{tot}	$T_C = 25^\circ\text{C}$, $T_J = 150^\circ\text{C}$	390	W
T_J		-40 ... +150	$^\circ\text{C}$
T_{JM}		150	$^\circ\text{C}$
T_{stg}		-40 ... +125	$^\circ\text{C}$
V_{ISOL}	50/60 Hz $I_{ISOL} \leq 1 \text{ mA}$	$t = 1 \text{ min}$ $t = 1 \text{ s}$	3000 3600 V~
M_d	Mounting torque(M5 or 10-32 UNF) Terminal connection torque (M5)	2.5-4.0/22-35	Nm/lb.in. Nm/lb.in.
Weight	Typical including screws	90	g

TO-240 AA
E 72873

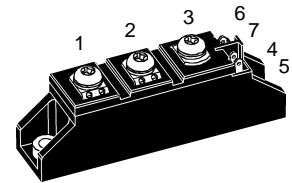

1, 3 = Drain, 2 = Common Source
5, 6 = Gate, 4, 7 = Kelvin Source

Features

- Two MOSFET with common source
- International standard package JEDEC TO-240 AA
- Direct copper bonded Al_2O_3 ceramic base plate
- Isolation voltage 3000 V~
- Low $R_{DS(on)}$ HDMOS™ process
- Low package inductance for high speed switching
- Kelvin source contact
- Keyed twin plugs

Applications

- Push-pull inverters
- Switched-mode and resonant-mode power supplies
- Uninterruptible power supplies (UPS)
- AC static switches

Advantages

- Easy to mount with two screws
- Space and weight savings
- High power density
- Low losses

Symbol	Conditions	Characteristic Values ($T_J = 25^\circ\text{C}$, unless otherwise specified)		
		min.	typ.	max.
V_{DSS}	$V_{GS} = 0 \text{ V}$, $I_D = 1 \text{ mA}$	70		V
$V_{GS(th)}$	$V_{DS} = V_{GS}$, $I_D = 8 \text{ mA}$	2		V
I_{GSS}	$V_{GS} = \pm 20 \text{ V DC}$, $V_{DS} = 0$			500 nA
I_{DSS}	$V_{DS} = V_{DSS}$, $V_{GS} = 0 \text{ V}$, $T_J = 25^\circ\text{C}$ $V_{DS} = 0.8 \cdot V_{DSS}$, $V_{GS} = 0 \text{ V}$, $T_J = 125^\circ\text{C}$			200 μA 1 mA
$R_{DS(on)}$	$V_{GS} = 10 \text{ V}$, $I_D = 0.5 \cdot I_{D25}$ Pulse test, $t \leq 300 \mu\text{s}$, duty cycle $d \leq 2 \%$		6	7 m Ω

Data per MOSFET unless otherwise stated.

Symbol	Conditions	Characteristic Values		
		(T _J = 25°C, unless otherwise specified)		
		min.	typ.	max.
g_{fs}	V _{DS} = 10 V; I _D = 0.5 • I _{D25} pulsed	60	80	S
C_{iss}	V _{GS} = 0 V, V _{DS} = 25 V, f = 1 MHz		8.8	nF
C_{oss}			4.0	nF
C_{rss}			2.4	nF
t_{d(on)}	V _{GS} = 10 V, V _{DS} = 0.5 • V _{DSS} , I _D = 0.5 • I _{D25} R _G = 1 Ω (External), resistive load		120	ns
t_r			280	ns
t_{d(off)}			390	ns
t_f			110	ns
Q_g	V _{GS} = 10 V, V _{DS} = 0.5 • V _{DSS} , I _D = 0.5 • I _{D25}		480	nC
Q_{gs}			60	nC
Q_{gd}			240	nC
R_{thJC}	with heat transfer paste			0.32 K/W
R_{thCH}			0.2	K/W
d_s	Creepage distance on surface	12.7		mm
d_A	Strike distance through air	9.6		mm
a	Max. allowable acceleration	50		m/s ²

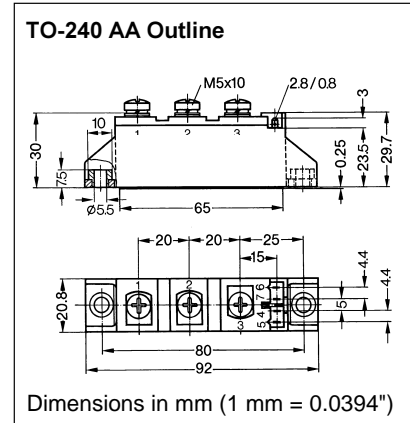
Source-Drain Diode

Symbol	Conditions	Characteristic Values		
		(T _J = 25°C, unless otherwise specified)		
		min.	typ.	max.
I_S	V _{GS} = 0 V			165 A
I_{SM}	Repetitive; pulse width limited by T _{JM}			660 A
V_{SD}	I _F = I _S ; V _{GS} = 0 V, Pulse test, t ≤ 300 μs, duty cycle d ≤ 2 %			1.5 V
t_{rr}	I _F = 50 A, -di/dt = 200 A/μs, V _{DS} = 25 V, V _{GS} = 0 V		150	ns