

# Linear Power MOSFET IXTN62N50L

## With Extended FBSOA

N-Channel Enhancement Mode

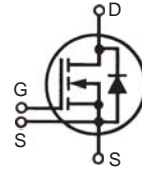

$$V_{DSS} = 500 \text{ V}$$

$$I_{D25} = 62 \text{ A}$$

$$R_{DS(on)} \leq 0.1 \text{ } \Omega$$

Symbol	Test Conditions	Maximum Ratings
$V_{DSS}$	$T_J = 25^\circ\text{C}$ to $150^\circ\text{C}$	500 V
$V_{DGR}$	$T_J = 25^\circ\text{C}$ to $150^\circ\text{C}$ ; $R_{GS} = 1 \text{ M}\Omega$	500 V
$V_{GS}$	Continuous	$\pm 30$ V
$V_{GSM}$	Transient	$\pm 40$ V
$I_{D25}$	$T_C = 25^\circ\text{C}$	62 A
$I_{DM}$	$T_C = 25^\circ\text{C}$ , pulse width limited by $T_{JM}$	150 A
$I_{AR}$	$T_C = 25^\circ\text{C}$	62 A
$E_{AR}$	$T_C = 25^\circ\text{C}$	80 mJ
$E_{AS}$	$T_C = 25^\circ\text{C}$	5.0 J
$P_D$	$T_C = 25^\circ\text{C}$	800 W
$T_J$		-55 to +150 $^\circ\text{C}$
$T_{JM}$		150 $^\circ\text{C}$
$T_{stg}$		-55 to +150 $^\circ\text{C}$
$V_{ISOL}$	50/60 Hz, RMS, $T = 1 \text{ min}$	2500 V~
	$I_{ISOL} \leq 1 \text{ mA}$ , $T = 1 \text{ s}$	3000 V~
$M_d$	Mounting torque for Base Plate	1.5/13 lb.in.
	Terminal connection torque	1.3/11.5 lb.in.
<b>Weight</b>		30 g

miniBLOC, SOT-227 B (IXTN)

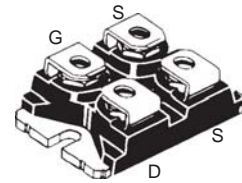

E153432

 G = Gate  
 S = Source  
 D = Drain

Either Source terminal S can be used as the Source terminal or the Kelvin Source (gate return) terminal.

### Features

- Designed for linear operation
- International standard package
- Molding epoxy meets UL94 V-0 flammability classification
- miniBLOC with Aluminium nitride isolation

### Applications

- Programmable loads
- Current regulators
- DC-DC converters
- Battery chargers
- DC choppers
- Temperature and lighting controls

### Advantages

- Easy to mount
- Space savings
- High power density

Symbol	Test Conditions	Characteristic Values ( $T_J = 25^\circ\text{C}$ , unless otherwise specified)		
		Min.	Typ.	Max.
$BV_{DSS}$	$V_{GS} = 0 \text{ V}$ , $I_D = 1 \text{ mA}$	500		V
$V_{GS(th)}$	$V_{DS} = V_{GS}$ , $I_D = 250 \text{ } \mu\text{A}$	3		V
$I_{GSS}$	$V_{GS} = \pm 30 \text{ V}$ , $V_{DS} = 0 \text{ V}$			$\pm 200 \text{ nA}$
$I_{DSS}$	$V_{DS} = V_{DSS}$ , $T_J = 25^\circ\text{C}$			50 $\mu\text{A}$
	$V_{GS} = 0 \text{ V}$ , $T_J = 125^\circ\text{C}$			1 mA
$R_{DS(on)}$	$V_{GS} = 20 \text{ V}$ , $I_D = 0.5 I_{D25}$ Note 1			0.10 $\Omega$

Symbol	Test Conditions	Characteristic Values			
		(T <sub>J</sub> = 25°C, unless otherwise specified)			
		Min.	Typ.	Max.	
<b>g<sub>fs</sub></b>	V <sub>DS</sub> = 10 V; I <sub>D</sub> = 0.5 • I <sub>D25</sub> , Note 1	10	15	20	S
<b>C<sub>iss</sub></b>	V <sub>GS</sub> = 0 V, V <sub>DS</sub> = 25 V, f = 1 MHz	11500		pF	
<b>C<sub>oss</sub></b>		1460		pF	
<b>C<sub>rss</sub></b>		210		pF	
<b>t<sub>d(on)</sub></b>	V <sub>GS</sub> = 15 V, V <sub>DS</sub> = 0.5 • V <sub>DSS</sub> , I <sub>D</sub> = 0.5 • I <sub>D25</sub> R <sub>G</sub> = 2 Ω (External),	36		ns	
<b>t<sub>r</sub></b>		85		ns	
<b>t<sub>d(off)</sub></b>		110		ns	
<b>t<sub>f</sub></b>		75		ns	
<b>Q<sub>g(on)</sub></b>	V <sub>GS</sub> = 20 V, V <sub>DS</sub> = 0.5 • V <sub>DSS</sub> , I <sub>D</sub> = 0.5 • I <sub>D25</sub>	550		nC	
<b>Q<sub>gs</sub></b>		115		nC	
<b>Q<sub>gd</sub></b>		180		nC	
<b>R<sub>thJC</sub></b>				0.156 °C/W	
<b>R<sub>thCS</sub></b>		0.05		°C/W	

**Safe Operating Area Specification**

Symbol	Test Conditions	Min.	Typ.	Max.
<b>SOA</b>	V <sub>DS</sub> = 400 V, I <sub>D</sub> = 0.75 A, T <sub>C</sub> = 90°C	300		W

**Source-Drain Diode**

Symbol	Test Conditions	Characteristic Values		
		(T <sub>J</sub> = 25°C, unless otherwise specified)		
		Min.	Typ.	Max.
<b>I<sub>S</sub></b>	V <sub>GS</sub> = 0 V			62 A
<b>I<sub>SM</sub></b>	Repetitive; pulse width limited by T <sub>JM</sub>			176 A
<b>V<sub>SD</sub></b>	I <sub>F</sub> = I <sub>S</sub> , V <sub>GS</sub> = 0 V, Note 1			1.5 V
<b>t<sub>rr</sub></b>	I <sub>F</sub> = I <sub>S</sub> , -dt/dt = 100 A/μs, V <sub>R</sub> = 100 V		500	ns

Note 1: Pulse test, t &lt; 300 μs, duty cycle, d ≤ 2 %

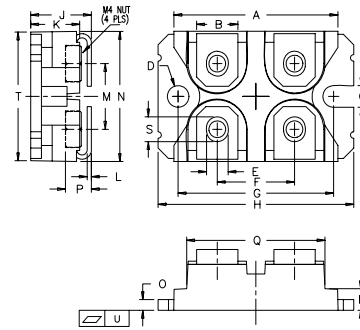
**SOT-227B (IXTN) Outline**

(M4 screws (4x) supplied)

SYM	INCHES		MILLIMETERS	
	MIN	MAX	MIN	MAX
A	1.240	1.255	31.50	31.88
B	.307	.323	7.80	8.20
C	.161	.169	4.09	4.29
D	.161	.169	4.09	4.29
E	.161	.169	4.09	4.29
F	.587	.595	14.91	15.11
G	1.186	1.193	30.12	30.30
H	1.496	1.505	38.00	38.23
J	.460	.481	11.68	12.22
K	.351	.378	8.92	9.60
L	.030	.033	0.76	0.84
M	.496	.506	12.60	12.85
N	.990	1.001	25.15	25.42
O	.078	.084	1.98	2.13
P	.195	.235	4.95	5.97
Q	1.045	1.059	26.54	26.90
R	.155	.174	3.94	4.42
S	.186	.191	4.72	4.85
T	.968	.987	24.59	25.07
U	-.002	.004	-0.05	0.1

**PRELIMINARY TECHNICAL INFORMATION**

The product presented herein is under development. The Technical Specifications offered are derived from data gathered during objective characterizations of preliminary engineering lots; but also may yet contain some information supplied during a pre-production design evaluation. IXYS reserves the right to change limits, test conditions, and dimensions without notice.

IXYS reserves the right to change limits, test conditions, and dimensions.

IXYS MOSFETs and IGBTs are covered by one or more of the following U.S. patents:	4,835,592	4,931,844	5,049,961	5,237,481	6,162,665	6,404,065 B1	6,683,344	6,727,585	7,005,734 B2	7,157,338B2
	4,850,072	5,017,508	5,063,307	5,381,025	6,259,123 B1	6,534,343	6,710,405 B2	6,759,692	7,063,975 B2	
	4,881,106	5,034,796	5,187,117	5,486,715	6,306,728 B1	6,583,505	6,710,463	6,771,478 B2	7,071,537	

**Fig. 1. Output Characteristics @ 25°C**

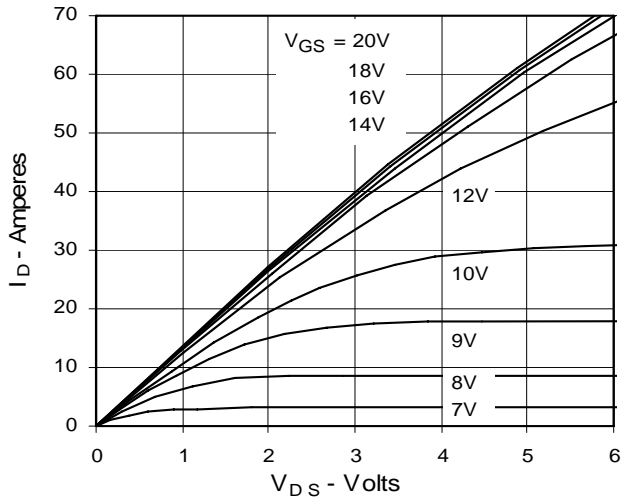

**Fig. 2. Extended Output Characteristics @ 25°C**

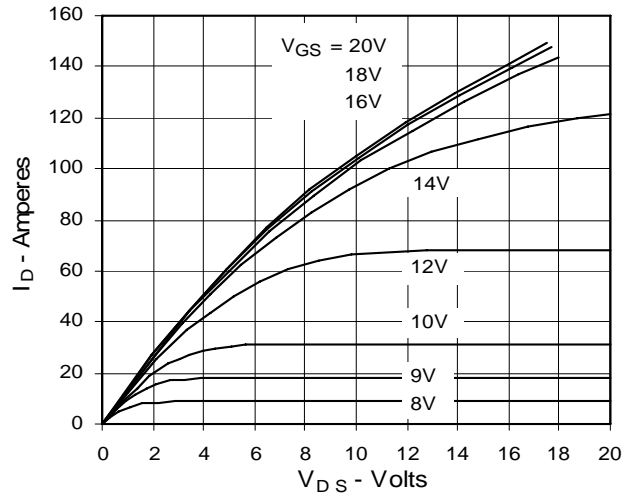

**Fig. 3. Output Characteristics @ 125°C**

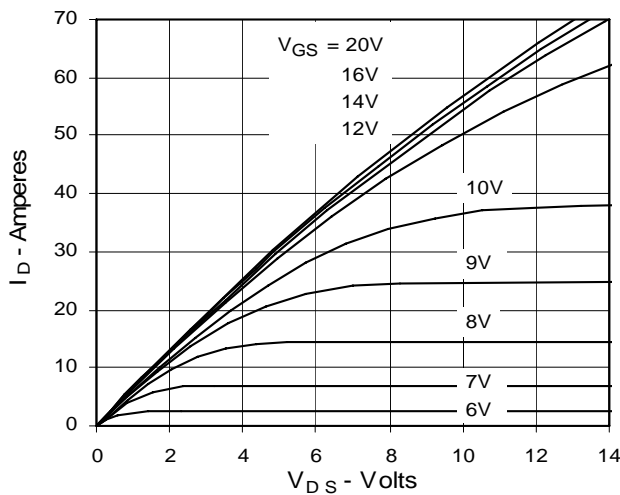

**Fig. 4.  $R_{DS(on)}$  Normalized to 0.5  $I_{D25}$  Value vs. Junction Temperature**

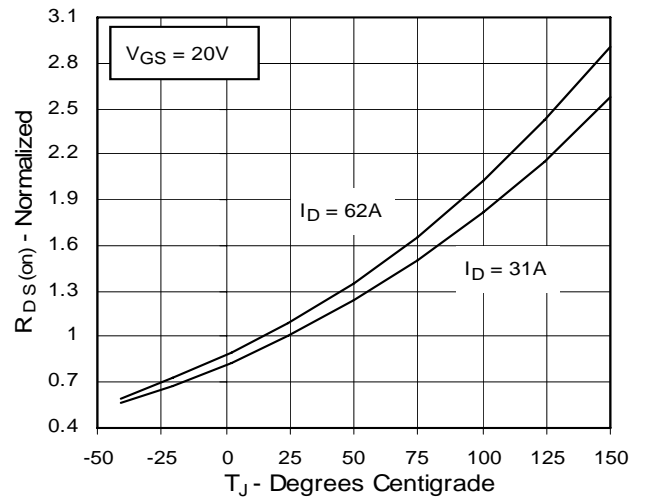

**Fig. 5.  $R_{DS(on)}$  Normalized to 0.5  $I_{D25}$  Value vs.  $I_D$**

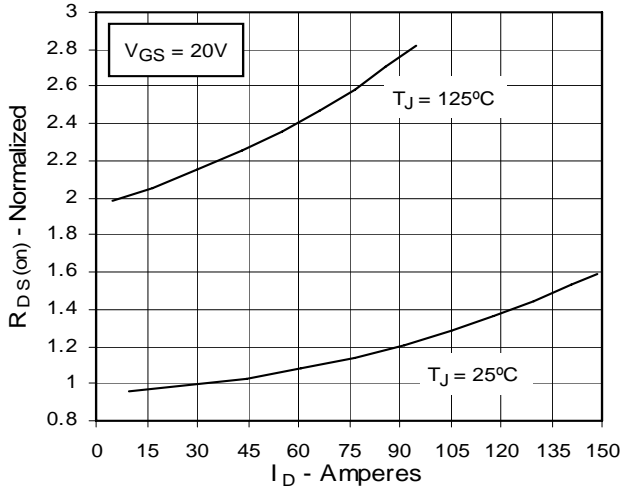

**Fig. 6. Drain Current vs. Case Temperature**

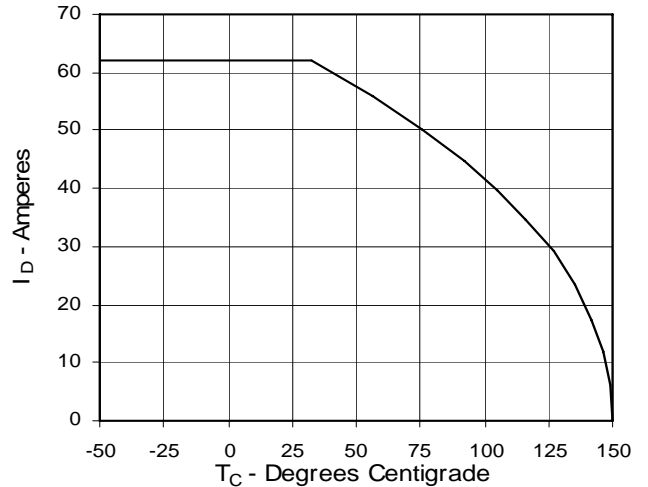

**Fig. 7. Input Admittance**

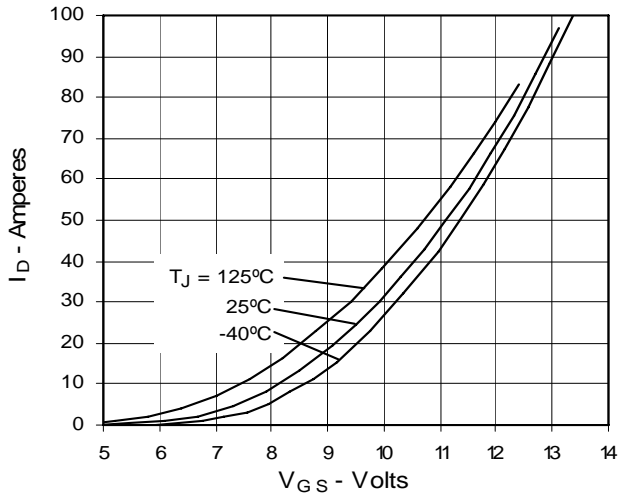

**Fig. 8. Transconductance**

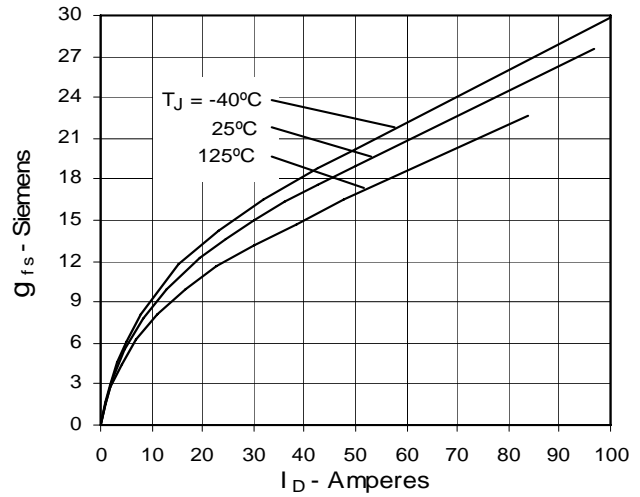

**Fig. 9. Source Current vs. Source-To-Drain Voltage**

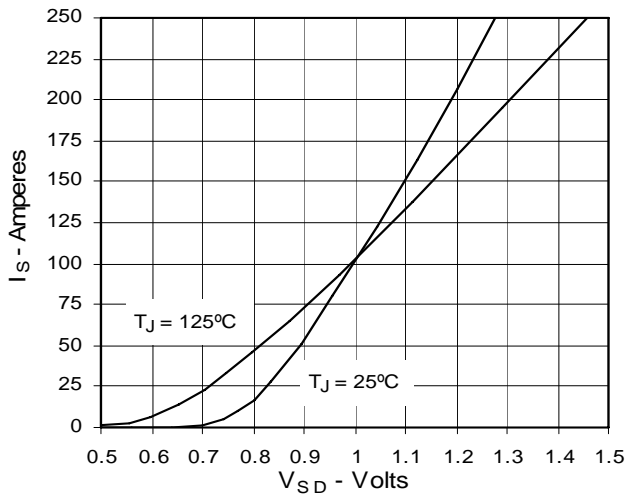

**Fig. 10. Gate Charge**

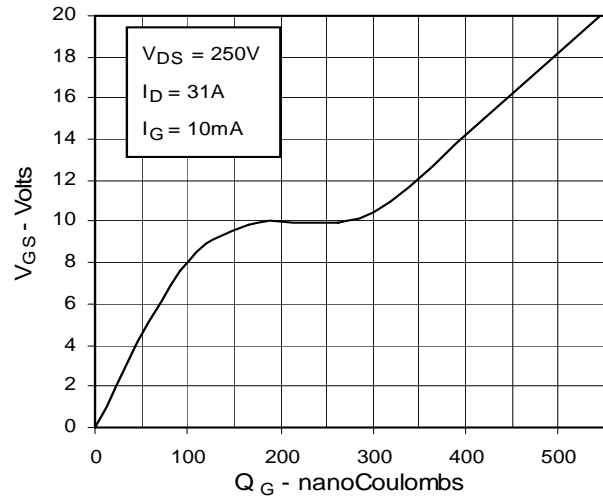

**Fig. 11. Capacitance**

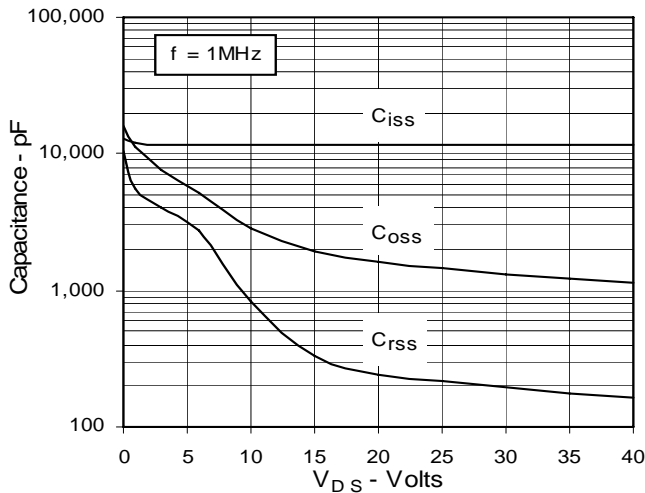

**Fig. 12. Forward-Bias Safe Operating Area @  $T_C = 25^\circ\text{C}$**

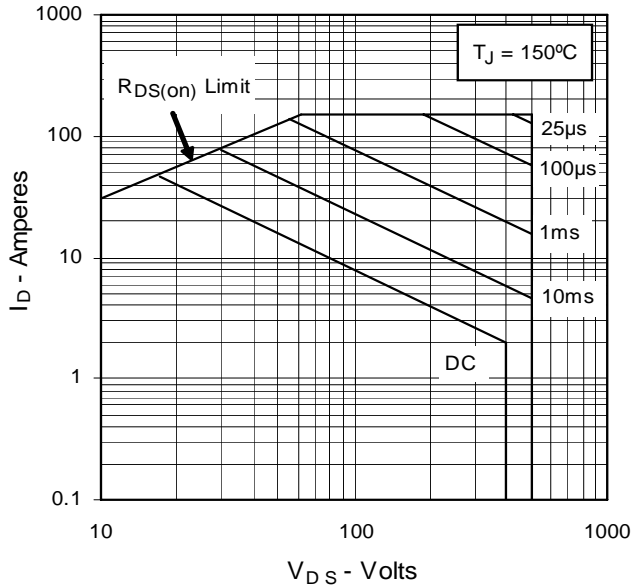

**Fig. 13. Forward-Bias Safe Operating Area @  $T_C = 90^\circ\text{C}$**

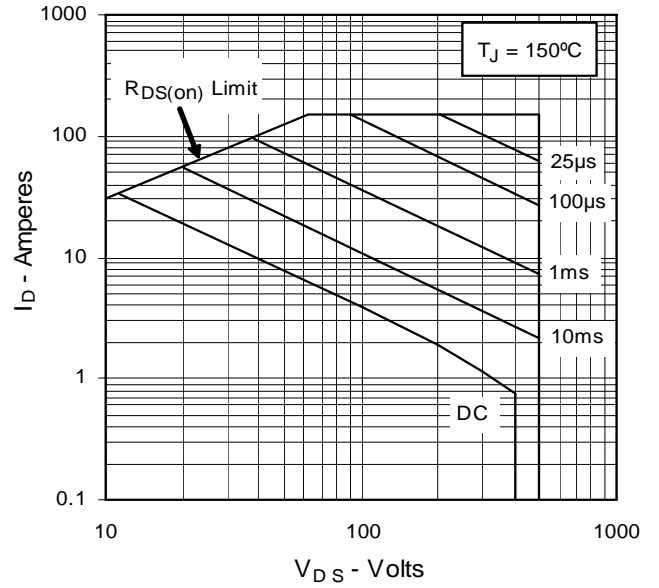

**Fig. 14. Maximum Transient Thermal Impedance**

