

Powerex, Inc., 200 Hillis Street, Youngwood, Pennsylvania 15697-1800 (412) 925-7272
 Powerex, Europe, S.A. 428 Avenue G. Durand, BP107, 72003 Le Mans, France (43) 41.14.14

General Purpose Rectifier
 1000 Amperes Average
 1500 Volts

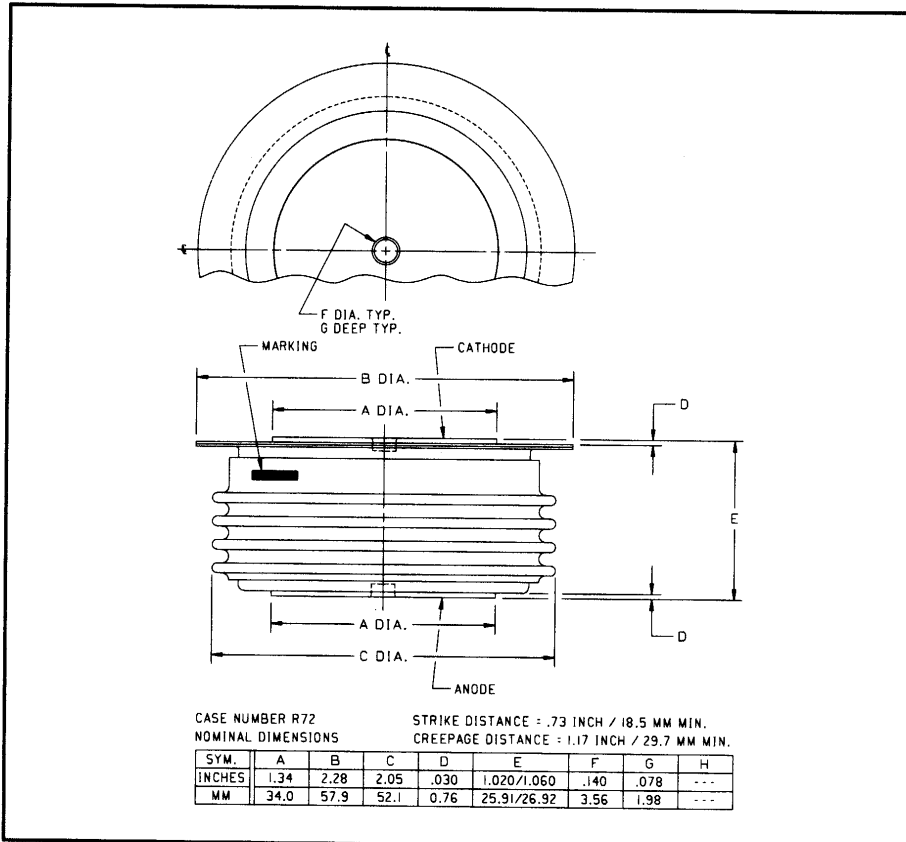

A430 (Outline Drawing)

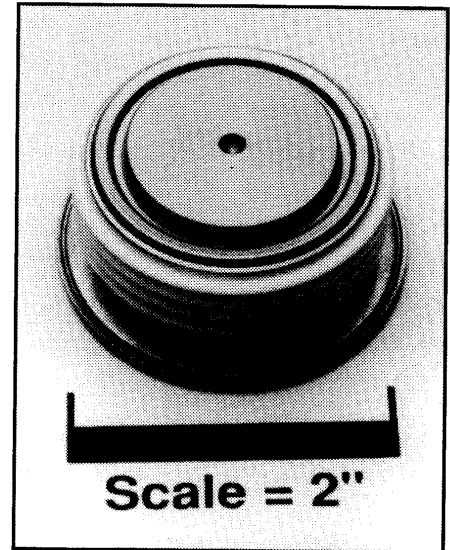

A430 General Purpose Rectifier
 1000 Amperes Average, 1500 Volts

Ordering Information:

Select the complete five or six digit part number you desire from the table, i.e. A430PE is a 1500 Volt, 1000 Ampere General Purpose Rectifier.

Type	Voltage		Current $I_T(av)$
	V_{RRM}	Code	
A430	600	M	1000
	800	N	
	1000	P	
	1200	PB	
	1400	PD	
	1500	PE	

Description:

Powerex General Purpose Rectifiers are designed for high blocking voltage capability with low forward voltage to minimize conduction losses. These hermetic Pow-R-Disc devices can be mounted using commercially available clamps and heatsinks.

Features:

- Low Forward Voltage
- Low Thermal Impedance
- Hermetic Packaging
- Excellent Surge and I^2t Ratings

Applications:

- Power Supplies
- Motor Control
- Free Wheeling Diodes
- Battery Chargers
- Resistance Welding



Powerex, Inc., 200 Hillis Street, Youngwood, Pennsylvania 15697-1800 (412) 925-7272
Powerex, Europe, S.A. 428 Avenue G. Durand, BP107, 72003 Le Mans, France (43) 41.14.14

A430
General Purpose Rectifier
1000 Amperes Average, 1500 Volts

Absolute Maximum Ratings

Characteristics	Symbol	A430	Units
Non-repetitive Transient Peak Reverse Voltage	V_{RSM}	$V_{RRM} + 100V$	Volts
RMS Forward Current, $T_C = 124^\circ C$	$I_{F(rms)}$	1570	Amperes
Average Current 180° Sine Wave, $T_C = 124^\circ C$	$I_{F(av)}$	1000	Amperes
RMS Forward Current, $T_C = 55^\circ C$	$I_{F(rms)}$	2160	Amperes
Average Current 180° Sine Wave, $T_C = 55^\circ C$	$I_{F(av)}$	1375	Amperes
Peak One Cycle Surge Forward Current (Non-repetitive) 60Hz	I_{fsm}	10000	Amperes
Peak One Cycle Surge Forward Current (Non-repetitive) 50Hz	I_{fsm}	9125	Amperes
I^2t (for Fusing) for One Cycle, 60Hz	I^2t	415,000	A^2sec
I^2t for $t_p \geq 1.5$ msec (Non-repetitive)	I^2t	200,000	A^2sec
Operating Temperature	T_j	-40 to +200°C	°C
Storage Temperature	T_{stg}	-40 to +200°C	°C
Approximate Weight		8	oz.
		227	g
Mounting Force		1800 to 2200	lb.
		8 to 9.8	kN

A430

General Purpose Rectifier

1000 Amperes Average, 1500 Volts

Electrical Characteristics, $T_j = 25^\circ\text{C}$ Unless Otherwise Specified

Characteristics	Symbol	Test Conditions	Min.	Typ.	Max.	Units
Repetitive Peak Reverse Leakage Current	I_{RRM}	$T_j = 200^\circ\text{C}$, $V_R = V_{RRM}$			50	mA
Forward Voltage Drop	V_{FM}	$T_C = 113^\circ\text{C}$, $I_{FM} = 3140\text{A Peak}$ Duty Cycle < 0.1%			1.42	Volts
Threshold Voltage, Low-level	$V_{(TO)1}$	$T_j = 200^\circ\text{C}$, $I = 15\%$, $I_{T(av)}$ to $\pi I_{T(av)}$			0.62038	Volts
Slope Resistance, Low-level	r_{T1}				0.2540	m Ω
Threshold Voltage, High-level	$V_{(TO)2}$	$T_j = 200^\circ\text{C}$, $I = \pi I_{T(av)}$ to I_{TSM}			0.91468	Volts
Slope Resistance, High-level	r_{T2}				0.1641	m Ω
V_{TM} Coefficients, Low-level		$T_j = 200^\circ\text{C}$, $I = 15\% I_{T(av)}$ to $\pi I_{T(av)}$				
					$A_1 = 0.84432$	
					$B_1 = -0.11705$	
					$C_1 = -2.953\text{E-}05$	
					$D_1 = 0.02886$	
V_{TM} Coefficients, High-level		$T_j = 200^\circ\text{C}$, $I = \pi I_{T(av)}$ to I_{TSM}				
					$A_2 = 3.7691$	
					$B_2 = -0.57841$	
					$C_2 = -5.094\text{E-}06$	
					$D_2 = 0.04152$	
Typical Reverse Recovery Time	t_{rr}	$T_C = 25^\circ\text{C}$, $I_{FM} = 1500\text{A}$, $di_F/dt = 25\text{A}/\mu\text{sec}$, $t_p = 190\mu\text{sec}$		10		μsec

Thermal Characteristics

Maximum Thermal Resistance, Double Sided Cooling

Junction-to-Case	$R_{\theta(j-c)}$	0.06	$^\circ\text{C/W}$
Case-to-Sink	$R_{\theta(c-s)}$	0.02	$^\circ\text{C/W}$

Powerex, Inc., 200 Hillis Street, Youngwood, Pennsylvania 15697-1800 (412) 925-7272
 Powerex, Europe, S.A. 428 Avenue G. Durand, BP107, 72003 Le Mans, France (43) 41.14.14

A430
General Purpose Rectifier
 1000 Amperes Average, 1500 Volts

Maximum On-State Forward Voltage Drop
 ($T_j = 200^\circ\text{C}$)

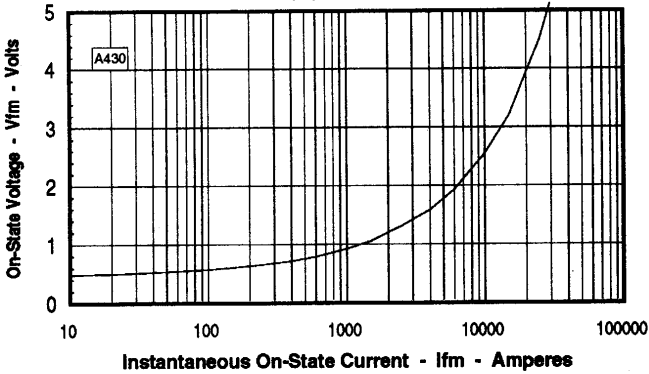

Maximum Transient Thermal Impedance
 (Junction to Case)

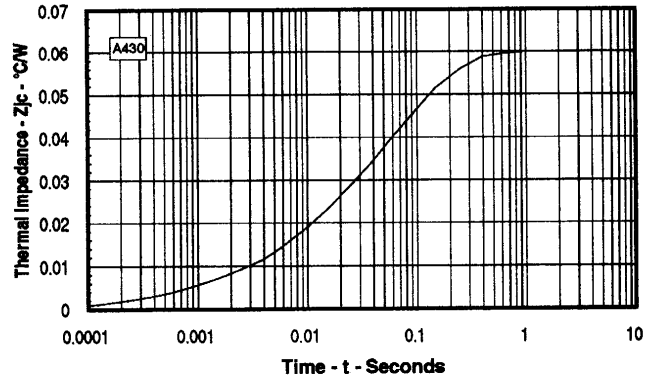

Maximum On-State Power Dissipation
 (Sinusoidal Waveform)

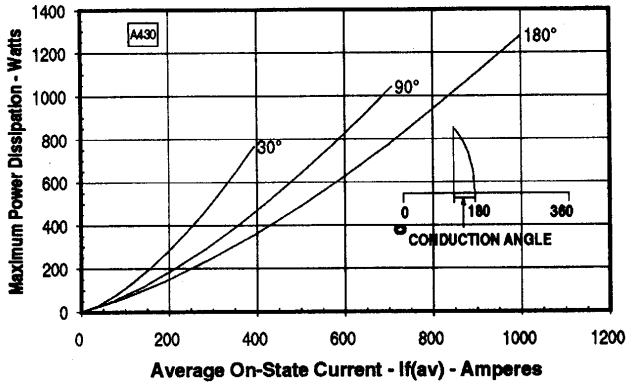

Maximum Allowable Case Temperature
 (Sinusoidal Waveform)

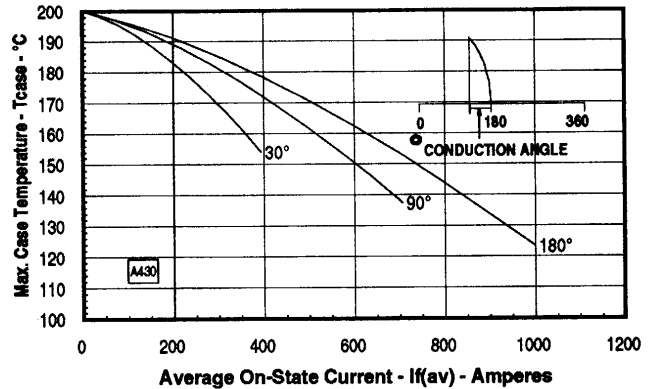

Maximum On-State Power Dissipation
 (Rectangular Waveform)

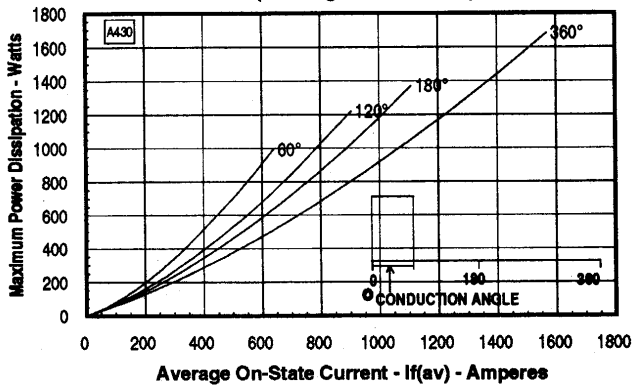

Maximum Allowable Case Temperature
 (Rectangular Waveform)

