

# 120 Amp Schottky Rectifier HS12035 – HS12045

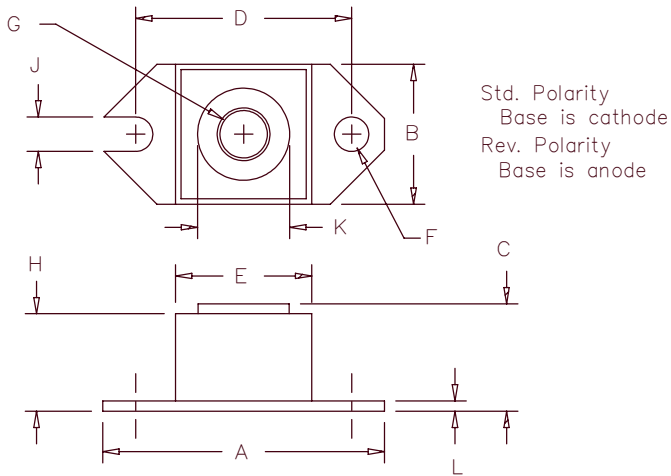

Dim.	Inches		Millimeter		Notes
	Minimum	Maximum	Minimum	Maximum	
A	1.52	1.56	38.86	39.62	
B	.725	.775	18.42	19.69	
C	.605	.625	15.37	15.88	
D	1.182	1.192	30.02	30.28	
E	.745	.755	18.92	19.18	Sq.
F	.152	.160	3.86	4.06	Dia.
G			1/4-20 UNC-2B		
H	.570	.580	14.49	14.73	
J	.156	.160	3.96	4.06	
K	.495	.505	12.57	12.83	Dia.
L	.120	.130	3.05	3.30	

Microsemi Catalog Number	Industry Part Number	Working Peak Reverse Voltage	Repetitive Peak Reverse Voltage
HS12035*	120NQ035 124NQ035 MBR12035	35V	35V
HS12040*	120NQ040 124NQ040 MBR12040	40V	40V
HS12045*	120NQ045 124NQ045 MBR12045	45V	45V

\* Add Suffix R for Reverse Polarity

- Schottky Barrier Rectifier
- Guard Ring Protection
- 120 Amperes/45 Volts
- 150°C Junction Temperature
- Reverse Energy Tested
- VRRM 35 – 45 Volts
- ROHS Compliant

## Electrical Characteristics

Average forward current	$I_F(AV)$ 120 Amps	$T_C = 100^\circ C$ , Square wave, $R_{\theta JC} = .40^\circ C/W$
Maximum surge current	$I_{FSM}$ 2000 Amps	8.3ms, half sine, $T_J = 125^\circ C$
Maximum repetitive reverse current	$I_R(OV)$ 2 Amps	$f = 1\text{ KHZ}$ , $25^\circ C$
Max peak forward voltage	$V_{FM}$ 0.49 Volts	$I_{FM} = 120A$ : $T_J = 125^\circ C^*$
Max peak forward voltage	$V_{FM}$ 0.55 Volts	$I_{FM} = 120A$ : $T_J = 25^\circ C^*$
Max peak reverse current	$I_{RM}$ 2A	$V_{RRM}$ , $T_J = 125^\circ C^*$
Max peak reverse current	$I_{RM}$ 5mA	$V_{RRM}$ , $T_J = 25^\circ C$
Typical junction capacitance	$C_J$ 5500pF	$V_R = 5.0V$ , $T_C = 25^\circ C$

\*Pulse test: Pulse width 300µsec, Duty cycle 2%

## Thermal and Mechanical Characteristics

Storage temp range	$T_{STG}$	-55°C to 150°C
Operating junction temp range	$T_J$	-55°C to 150°C
Max thermal resistance	$R_{\theta JC}$	0.40°C/W Junction to case
Typical thermal resistance (greased)	$R_{\theta CS}$	0.12°C/W Case to sink
Terminal Torque		35-40 inch pounds
Mounting Base Torque		20-25 inch pounds
Weight		1.1 ounces (32 grams) typical

# HS12035 – HS12045

Figure 1  
Typical Forward Characteristics

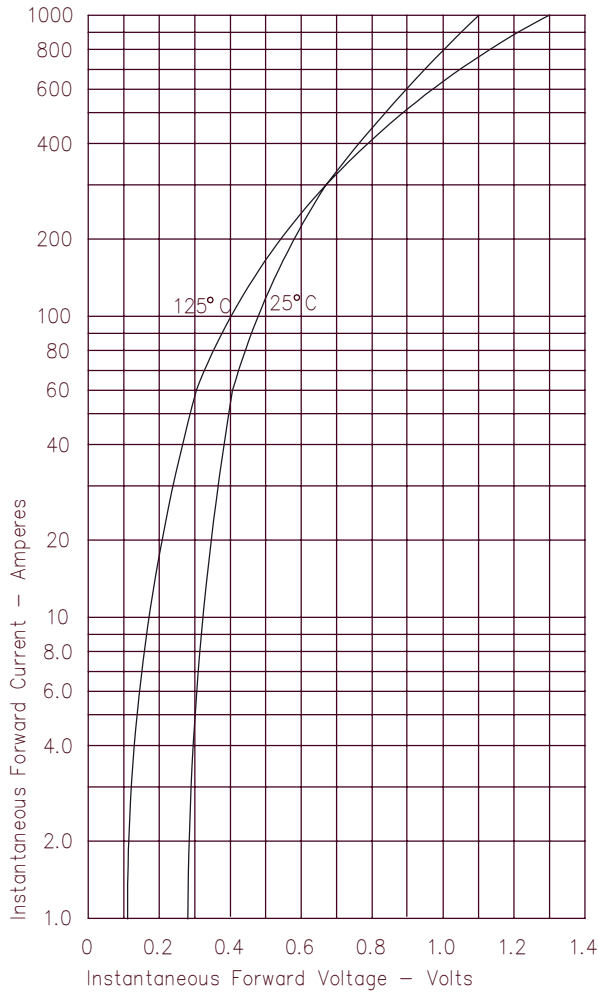

Figure 3  
Typical Junction Capacitance

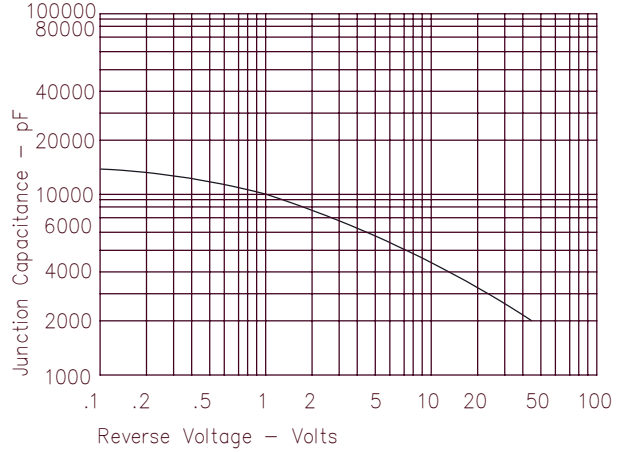

Figure 4  
Forward Current Derating

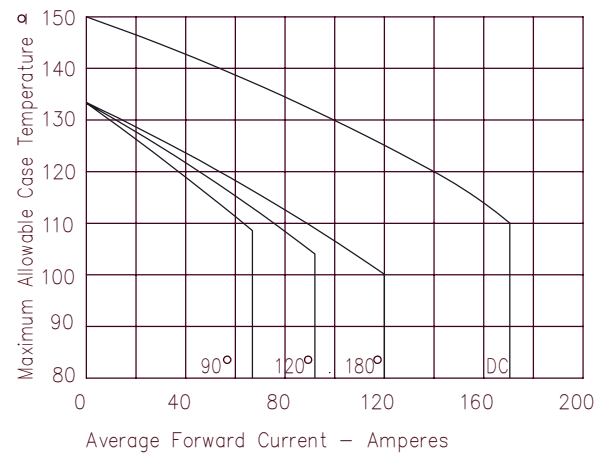

Figure 2  
Typical Reverse Characteristics

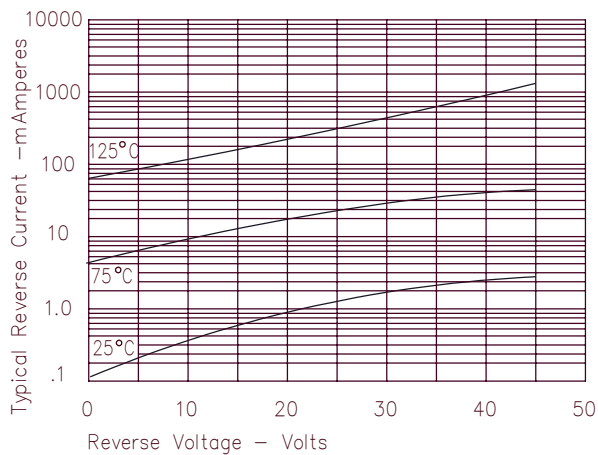

Figure 5  
Maximum Forward Power Dissipation

