

Single Phase Rectifier Bridge

$$I_{dAV} = 122 \text{ A}$$

$$V_{RRM} = 800-1800 \text{ V}$$

Preliminary data

V_{RSM} V	V_{RRM} V	Type
900	800	VBO 130-08NO7
1300	1200	VBO 130-12NO7
1700	1600	VBO 130-16NO7
1900	1800	VBO 130-18NO7

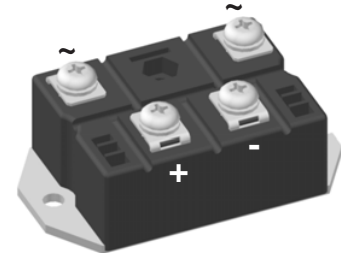
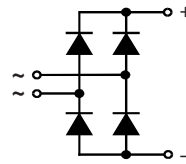

Symbol	Conditions	Maximum Ratings	
I_{dAV}	$T_C = 100^\circ\text{C}$, module	122 A	
I_{dAV}	$T_A = 35^\circ\text{C}$ ($R_{thCA} = 0.2 \text{ K/W}$), module	115 A	
I_{FSM}	$T_{VJ} = 45^\circ\text{C}$ $V_R = 0$	$t = 10 \text{ ms}$ (50 Hz), sine $t = 8.3 \text{ ms}$ (60 Hz), sine	1800 A 1950 A
	$T_{VJ} = T_{VJM}$ $V_R = 0$	$t = 10 \text{ ms}$ (50 Hz), sine $t = 8.3 \text{ ms}$ (60 Hz), sine	1600 A 1800 A
I^2t	$T_{VJ} = 45^\circ\text{C}$ $V_R = 0$	$t = 10 \text{ ms}$ (50 Hz), sine $t = 8.3 \text{ ms}$ (60 Hz), sine	16 200 A ² s 16 200 A ² s
	$T_{VJ} = T_{VJM}$ $V_R = 0$	$t = 10 \text{ ms}$ (50 Hz), sine $t = 8.3 \text{ ms}$ (60 Hz), sine	12 800 A ² s 13 400 A ² s
T_{VJ}		-40...+150 °C	
T_{VJM}		150 °C	
T_{stg}		-40...+125 °C	
V_{ISOL}	50/60 Hz, RMS $I_{ISOL} \leq 1 \text{ mA}$	$t = 1 \text{ min}$ $t = 1 \text{ s}$	2500 V~ 3000 V~
	M_d	Mounting torque (M6) Terminal connection torque (M6)	5 ±15% Nm 5 ±15% Nm
Weight	typ.		270 g

Features

- Package with screw terminals
- Isolation voltage 3000 V~
- Planar passivated chips
- Blocking voltage up to 1800 V
- Low forward voltage drop
- UL registered E 72873

Applications

- Supplies for DC power equipment
- Input rectifiers for PWM inverter
- Battery DC power supplies
- Field supply for DC motors

Advantages

- Easy to mount with two screws
- Space and weight savings
- Improved temperature and power cycling

Symbol	Conditions	Characteristic Values
I_R	$V_R = V_{RRM}$ $T_{VJ} = 25^\circ\text{C}$	$\leq 0.3 \text{ mA}$
	$V_R = V_{RRM}$ $T_{VJ} = T_{VJM}$	$\leq 5 \text{ mA}$
V_F	$I_F = 300 \text{ A}$ $T_{VJ} = 25^\circ\text{C}$	$\leq 1.65 \text{ V}$
V_{TO}	For power-loss calculations only	0.8 V
r_T	$T_{VJ} = T_{VJM}$	3 mΩ
R_{thJC}	per diode, 180°	0.65 K/W
	per module	0.108 K/W
R_{thJK}	per diode; 180°	0.83 K/W
	per module	0.138 K/W
d_S	Creeping distance on surface	10 mm
d_A	Creepage distance in air	9.4 mm
a	Max. allowable acceleration	50 m/s ²

Data according to IEC 60747 refer to a single diode unless otherwise stated.

IXYS reserves the right to change limits, test conditions and dimensions.

Dimensions in mm (1 mm = 0.0394")

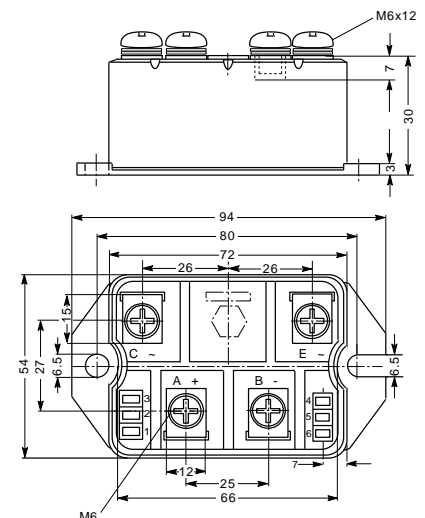

20100706b