

SL3ICS1002/1202

UCODE G2XM and G2XL

Rev. 3.5 — 2 November 2009
157335

Product short data sheet
CONFIDENTIAL

1. General description

The UHF EPCglobal Generation 2 standard allows the commercialized provision of mass adoption of UHF RFID technology for passive smart tags and labels. Main fields of applications are supply chain management and logistics for worldwide use with special consideration of European, US and Chinese frequencies to ensure that operating distances of several meters can be realized.

The G2X is a dedicated chip for passive, intelligent tags and labels supporting the EPCglobal Class 1 Generation 2 UHF RFID standard. It is especially suited for applications where operating distances of several meters and high anti-collision rates are required.

The G2X is a product out of the NXP Semiconductors UCODE product family. The entire UCODE product family offers anti-collision and collision arbitration functionality. This allows a reader to simultaneously operate multiple labels/tags within its antenna field. A UCODE G2X based label/ tag requires no external power supply.

Its contact-less interface generates the power supply via the antenna circuit by propagative energy transmission from the interrogator (reader), while the system clock is generated by an on-chip oscillator. Data transmitted from interrogator to label/tag is demodulated by the interface, and it also modulates the interrogator's electromagnetic field for data transmission from label/tag to interrogator. A label/tag can be operated without the need for line of sight or battery, as long as it is connected to a dedicated antenna for the targeted frequency range. When the label/tag is within the interrogator's operating range, the high-speed wireless interface allows data transmission in both directions.

In addition to the EPC specifications the G2X offers an integrated EAS (Electronic Article Surveillance) feature and read protection of the memory content. On top of the specification of the G2XL the G2XM offers 512-bit of user memory.



1.1 Air interface standards

The G2X is certified according EPCglobal 1.0.9 and fully supports all parts of the "Specification for RFID Air Interface EPCglobal, EPCTM Radio-Frequency Identity Protocols, Class-1 Generation-2 UHF RFID, Protocol for Communications at 860 MHz - 960 MHz, Version 1.1.0".



EPCglobal compliance and interoperability certification

2. Features

2.1 Key features

- 512-bit user memory (G2XM only)
- 240-bit of EPC memory
- 64-bit tag identifier (TID) including 32-bit unique serial number
- Memory read protection
- EAS (Electronic Article Surveillance) command
- Calibrate command
- 32-bit kill password to permanently disable the tag
- 32-bit access password to allow a transition into the secured transmission state
- Broad international operating frequency: from 840 MHz to 960 MHz
- Long read/write ranges due to extremely low power design
- Reliable operation of multiple tags due to advanced anti-collision
- Forward link: 40-160 kbit/s
- Return link: 40-640 kbit/s

2.2 Key benefits

- High sensitivity provides long read range
- Low Q-factor for consistent performance on different materials
- Improved interference suppression for reliable operation in multi-reader environment
- Large input capacitance for ease of assembly and high assembly yield
- Highly advanced anti-collision resulting in highest identification speed
- Reliable and robust RFID technology suitable for dense reader and noisy environments

2.3 Custom commands

- EAS Alarm
Enables the UHF RFID tag to be used as EAS tag without the need for a backend data base.
- Read Protect
Protects all memory content including CRC16 from unauthorized reading.
- Calibrate
Activates permanent back-scatter in order to evaluate the tag-to-reader performance.

3. Applications

- Supply chain management
- Item level tagging
- Asset management
- Container identification
- Pallet and case tracking
- Product authentication

4. Ordering information

Table 1. Ordering information G2XM

Type number	Package		Version
	Name	Description	
SL3ICS1002FUG/V7AF	Wafer	Bumped die on sawn wafer	-
SL3S1002FTT	TSSOP8	plastic thin shrink small outline package; 8 leads; body width 3 mm	SOT505-1
SL3S1002FTB1	XSON3	plastic extremely thin small outline package; 3 terminals; body 1 x 1.45 x 0,5 mm	SOT1122
SL3S1002AC0	FCS2	plastic flip chip strap package; 2 leads, 9 mm wide tape ^[1]	SOT1040-1
SL3S1002AC2	FCS2	plastic flip chip strap package; 2 leads; 9 mm wide tape ^[2]	SOT1040-1

Table 2. Ordering information G2XL

Type number	Package		Version
	Name	Description	
SL3ICS1202FUG/V7AF	Wafer	Bumped die on sawn wafer	-
SL3S1202FTT	TSSOP8	plastic thin shrink small outline package; 8 leads; body width 3 mm	SOT505-1
SL3S1202FTB1	XSON3	plastic extremely thin small outline package; 3 terminals; body 1 x 1.45 x 0,5 mm	SOT1122
SL3S1202AC0	FCS2	plastic flip chip strap package; 2 leads, 9 mm wide tape ^[1]	SOT1040-1
SL3S1202AC2	FCS2	plastic flip chip strap package; 2 leads; 9 mm wide tape ^[2]	SOT1040-1

[1] FCS2 Polymer Strap, JEDEC outline standard Copper

[2] FCS2 Polymer Strap, JEDEC outline standard Aluminum

5. Block diagram

The SL3ICS1002/1202 IC consists of three major blocks:

- Analog RF Interface
- Digital Controller
- EEPROM

The analog part provides stable supply voltage and demodulates data received from the reader for being processed by the digital part. Further, the modulation transistor of the analog part transmits data back to the reader.

The digital section includes the state machines, processes the protocol and handles communication with the EEPROM, which contains the EPC and the user data.

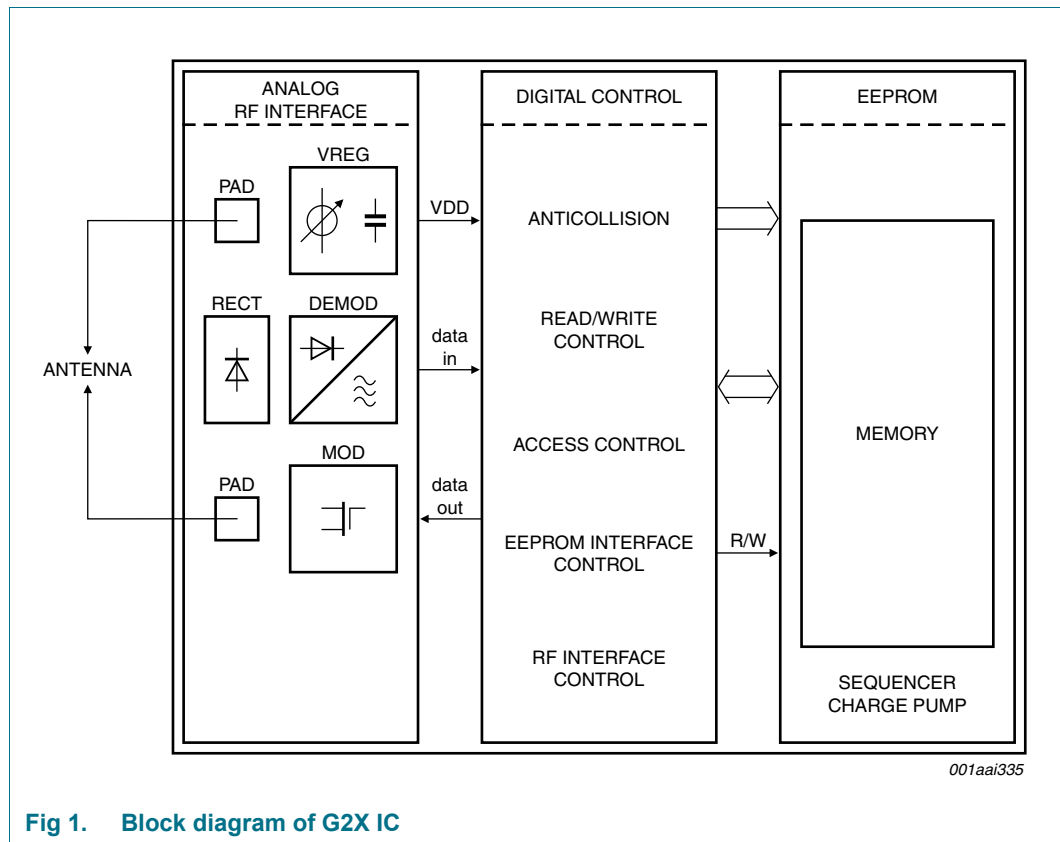
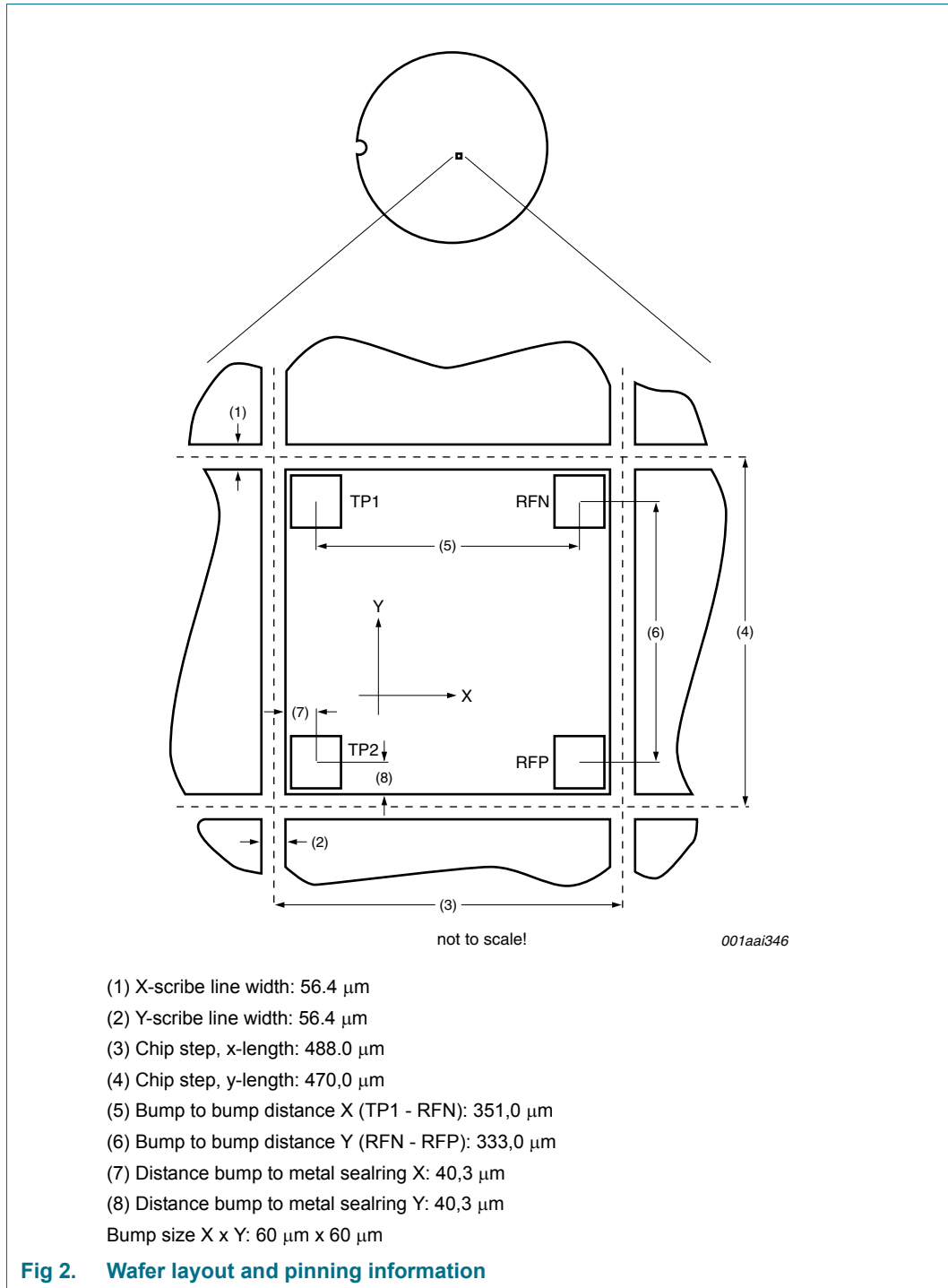

Fig 1. Block diagram of G2X IC

6. Wafer layout and pinning information

6.1 Wafer layout



6.2 FCS2 layout strap and pinning

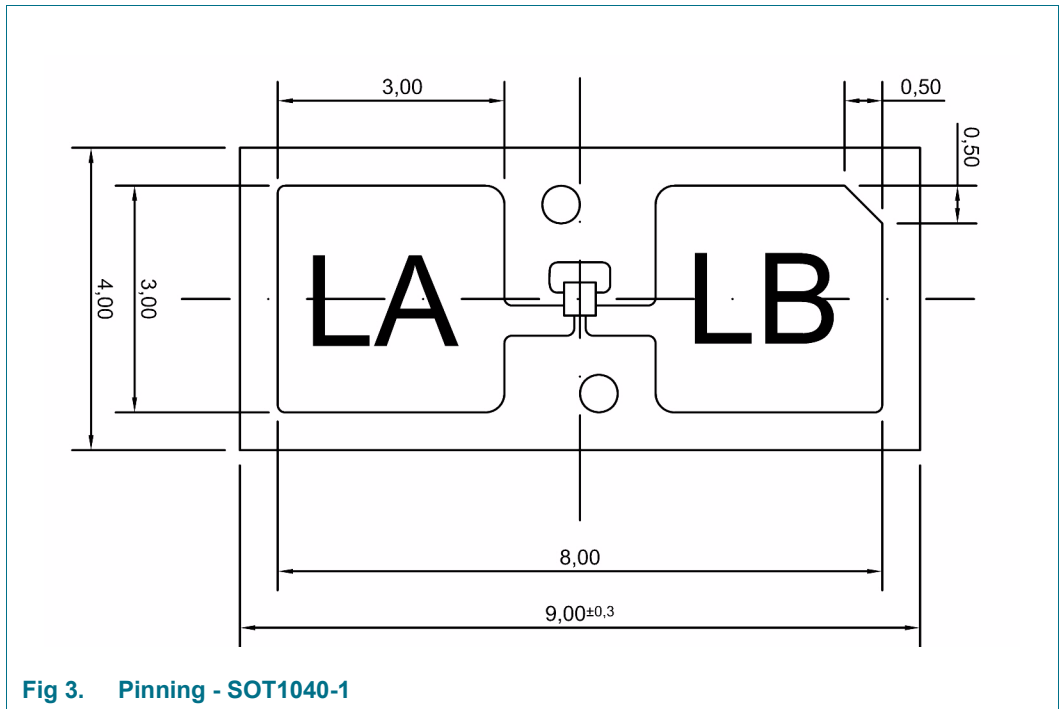

Fig 3. Pinning - SOT1040-1

Table 3. Pin description of SOT1040-1

Symbol	Pin	Description
LA		Antenna Connection 1
LB		Antenna Connection 2

7. Package outline

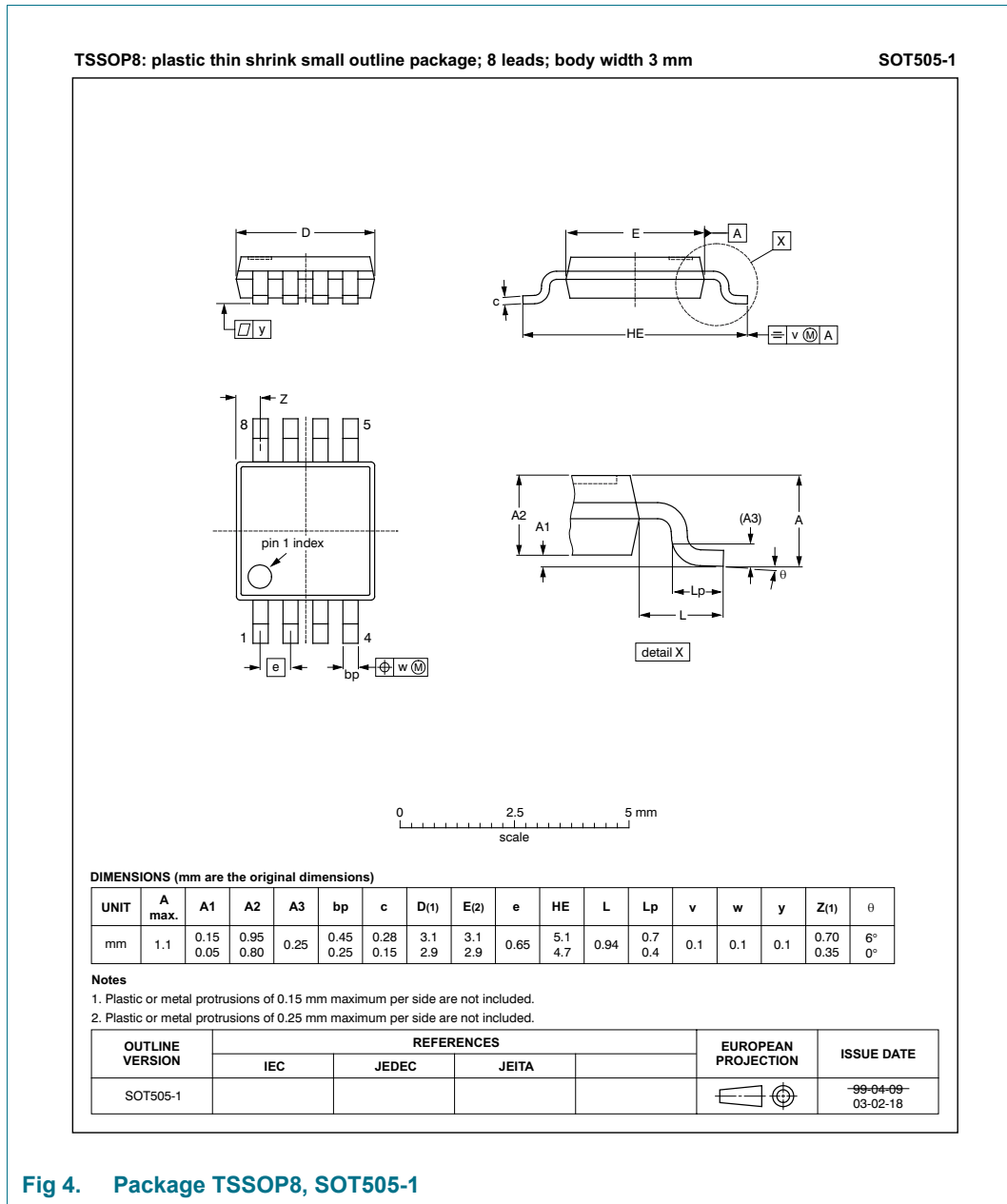

Fig 4. Package TSSOP8, SOT505-1

Table 4. Pin description of TSSOP8

Symbol	Pin	Description
RFN	1	Grounded antenna connector
-	2 to 7	Not used
RFP	8	Ungrounded antenna connector

XSON3: plastic extremely thin small outline package; no leads; 3 terminals; body 1 x 1.45 x 0.5 mm

SOT1122

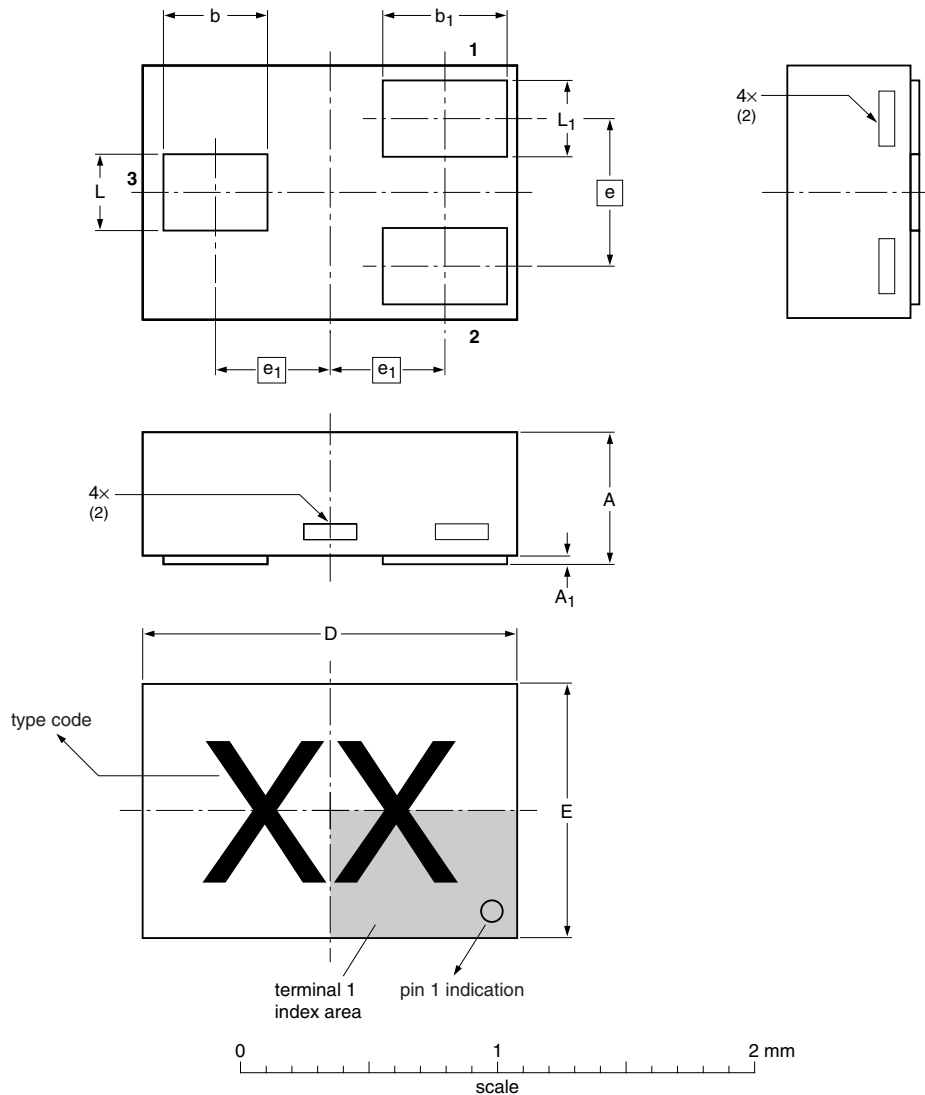

Dimensions

Unit	A ⁽¹⁾	A ₁	b	b ₁	D	E	e	e ₁	L	L ₁
max	0.50	0.04	0.45	0.55	1.50	1.05			0.35	0.30
mm nom			0.40	0.50	1.45	1.00	0.55	0.425	0.30	0.25
min			0.37	0.47	1.40	0.95			0.27	0.22

Notes

1. Dimension A is including plating thickness.
2. Can be visible in some manufacturing processes.

sot1122_po

Outline version	References			European projection	Issue date
	IEC	JEDEC	JEITA		
SOT1122		MO-252			09-10-09

Fig 5. Package outline SOT1122

Table 5. Pin description of SOT1122

Symbol	Pin	Description
RFP	1	Ungrouded antenna connector
RFN	2	Grounded antenna connector
n.c.	3	not connected

Table 6. SOT1122 Marking

Type	Type code (Marking)	Comment
SL3S1202FTB1	UL	UCODE G2XL
SL3S1002FTB1	UM	UCODE G2XM

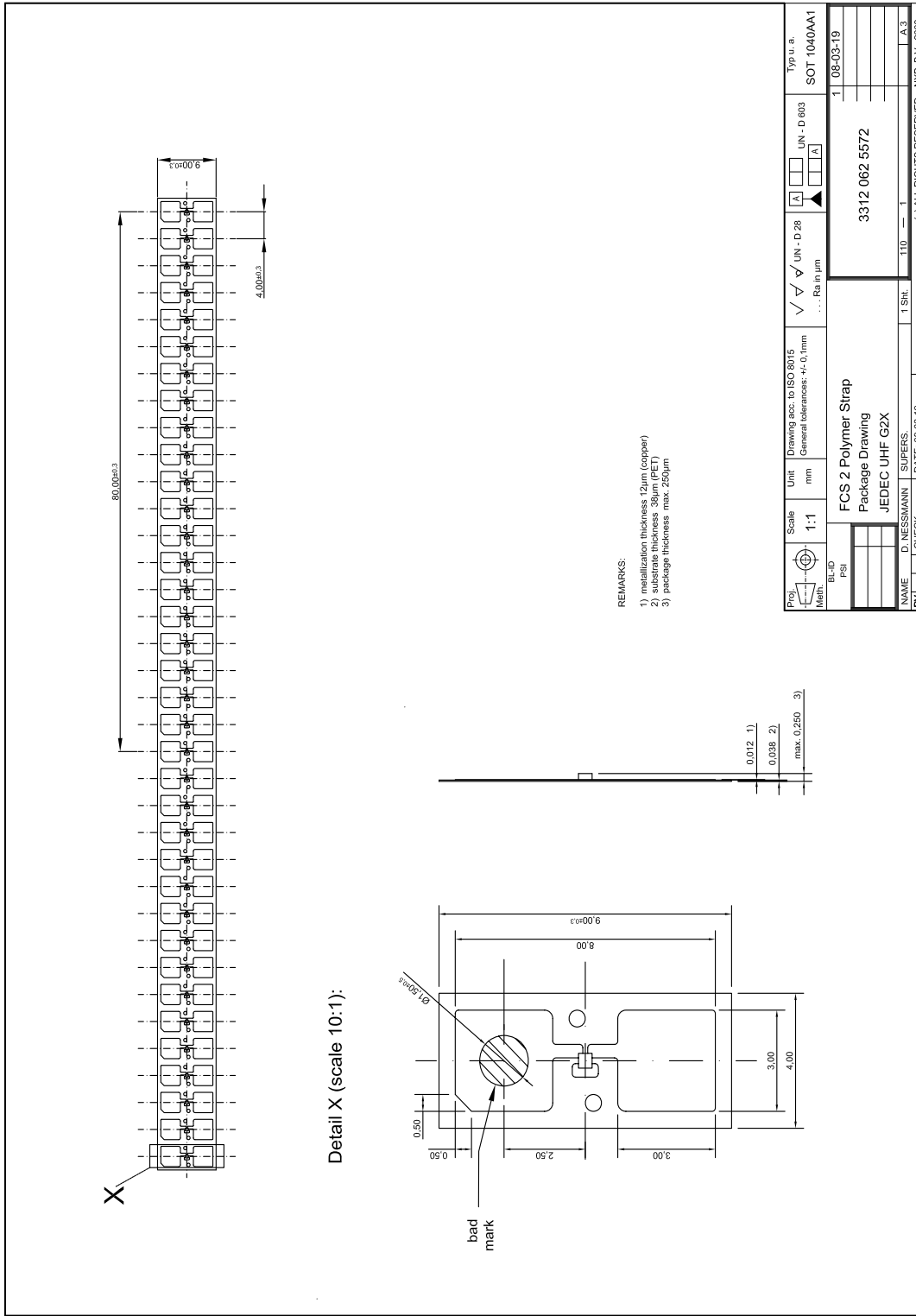

Fig 6. Package FCS2, SOT1040AA1, 12 μm Cu metallization

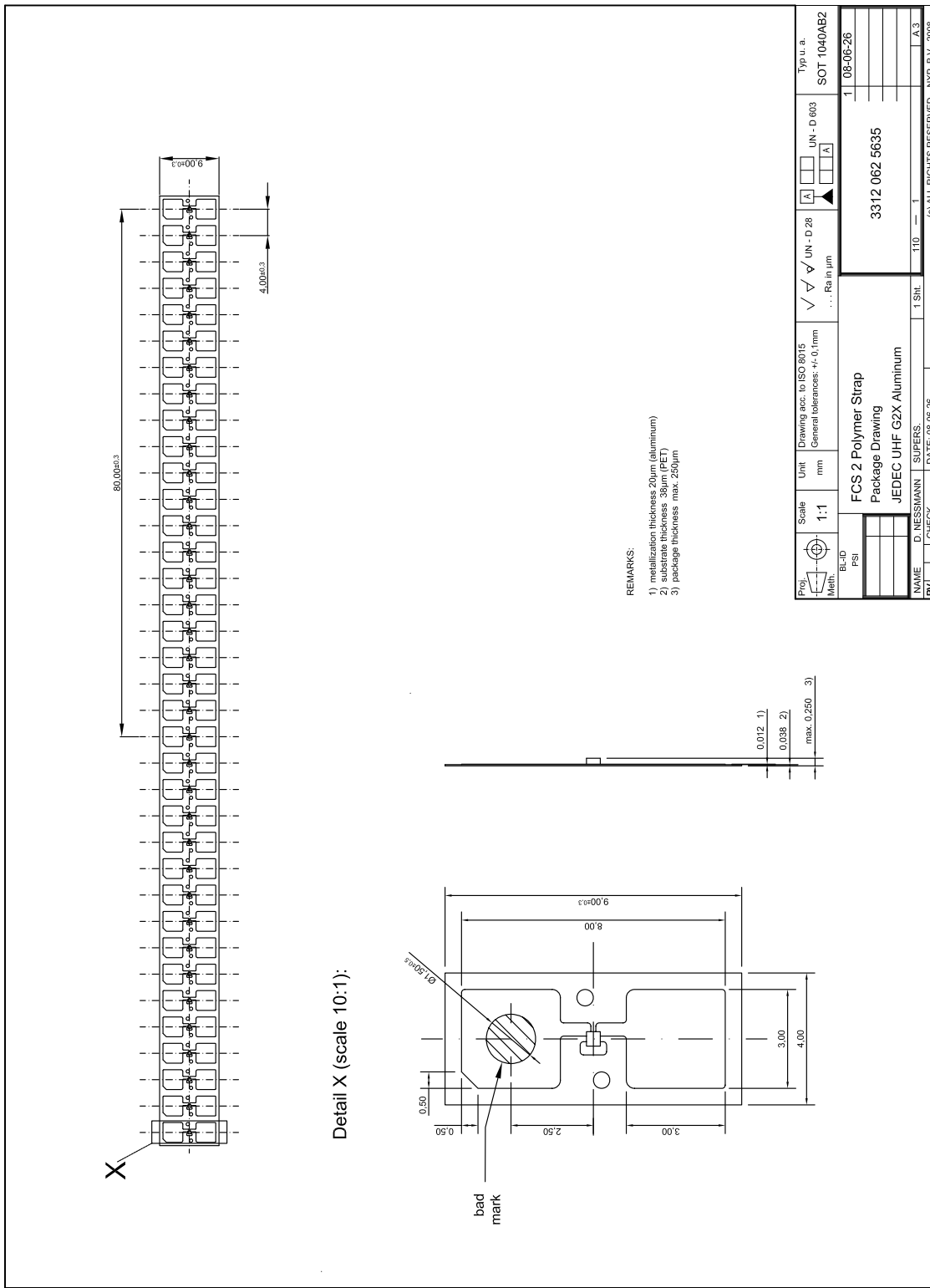

Fig 7. Package FCS2, SOT1040AB2, 20 μm Al metallization

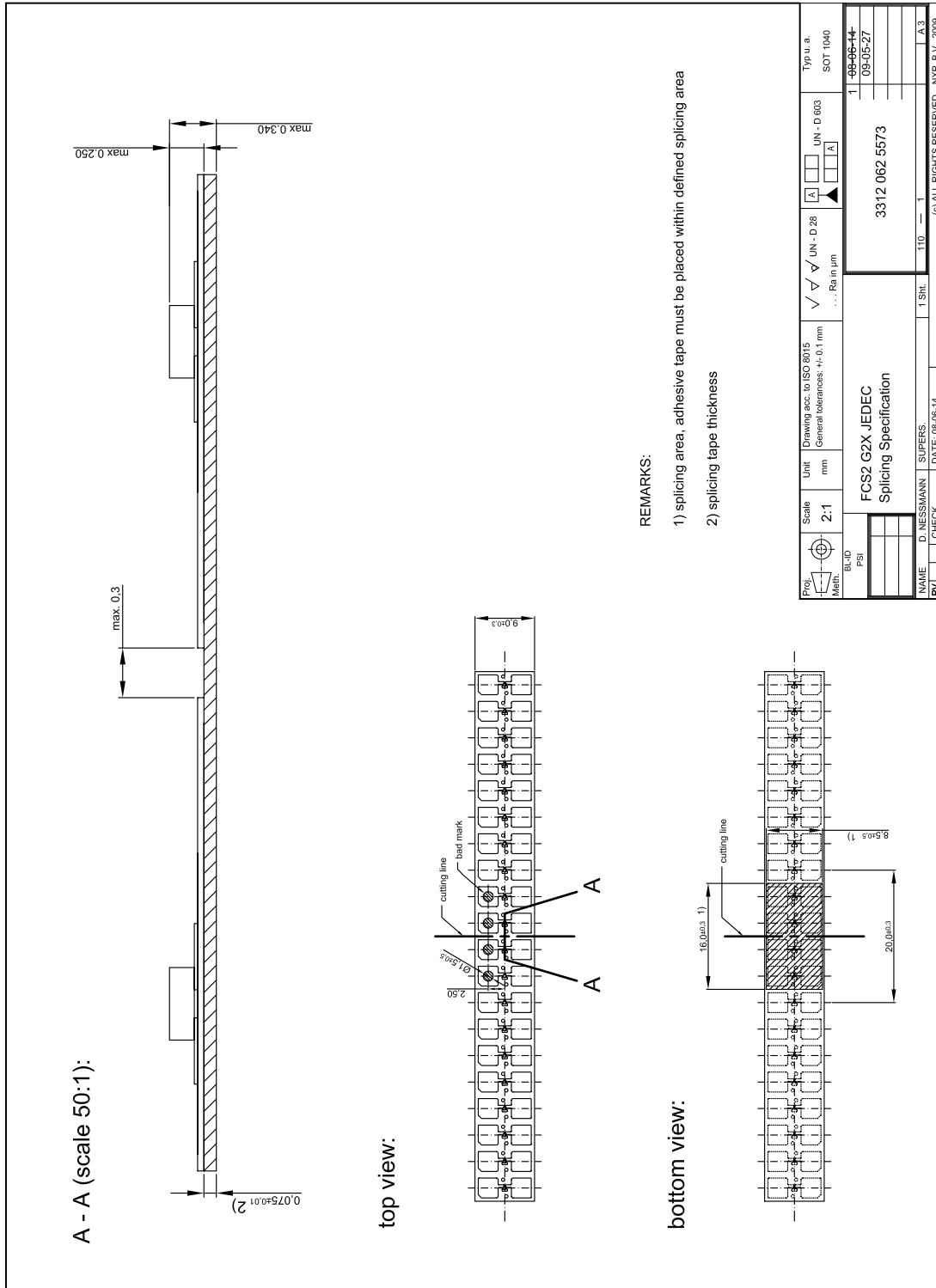

Fig 8. Splicing drawing SOT1040-1

8. Limiting values

Table 7. Limiting values^{[1][2]}

In accordance with the Absolute Maximum Rating System (IEC 60134)

Voltages are referenced to RFN

Symbol	Parameter	Conditions	Min	Max	Unit
Die					
T _{stg}	storage temperature range		-55	+125	°C
T _{oper}	operating temperature		-40	+85	°C
V _{ESD}	electrostatic discharge voltage	Human body model ^[3]	-	± 2	kV
TSSOP8, SOT1122					
T _{stg}	storage temperature range		-55	+125	°C
P _{tot}	total power dissipation		-	30	mW
T _{oper}	operating temperature		-40	+85	°C
V _{ESD}	electrostatic discharge voltage	Human body model	-	± 2	kV
SOT1040AA1, SOT1040AB2					
T _{oper}	operating temperature	^[3]	-40	+70	°C
r.h. _{stg}	relative humidity		-	60	%
T _{stg}	storage temperature range		+15	+30	°C
V _{ESD}	electrostatic discharge voltage	Human body model	-	± 2	kV
	antenna bonding				
	label converting				

- [1] Stresses above those listed under Absolute Maximum Ratings may cause permanent damage to the device. This is a stress rating only and functional operation of the device at these or any conditions other than those described in the Operating Conditions and Electrical Characteristics section of this specification is not implied.
- [2] This product includes circuitry specifically designed for the protection of its internal devices from the damaging effects of excessive static charge. Nonetheless, it is suggested that conventional precautions be taken to avoid applying greater than the rated maxima.
- [3] For ESD measurement, the die chip has been mounted into a CDIP20 package.

9. Characteristics

9.1 Wafer characteristics

Table 8. Wafer characteristics

Symbol	Parameter	Conditions	Min	Typ	Max	Unit
Memory characteristics						
t_{RET}	EEPROM data retention	$T_{\text{amb}} \leq 55\text{ °C}$	50	-	-	year
N_{WE}	EEPROM write endurance	$T_{\text{amb}} \leq 55\text{ °C}$	100000	-	-	cycle
Interface characteristics						
P_{tot}	total power dissipation			-	30	mW
f_{oper}	operating frequency		840	-	960	MHz
P_{min}	minimum operating power supply	[1][2]	-	-15	-	dBm
C_i	input capacitance (parallel)	[3]	-	0.88	-	pF
Q	quality factor ($\text{Im}(Z_{\text{chip}}) / \text{Re}(Z_{\text{chip}})$)	[3]	-	9	-	-
Z	impedance (915 MHz)		-	22 - j195	-	Ω
-	modulated jammer suppression ≥ 1.0 MHz	[4]	-	-4	-	dB
-	unmodulated jammer suppression ≥ 1.0 MHz	[4]	-	-4	-	dB

[1] Power to process a Query command

[2] Measured with a 50 Ω source impedance

[3] At minimum operating power

[4] Values measured for a 40 kHz phase reservall command under matched conditions

9.2 Package characteristics

Table 9. Package interface characteristics

Symbol	Parameter	Conditions	Min	Typ	Max	Unit
Interface characteristics SOT 1040AA1 (Cu strap)						
C_i	input capacitance	[1]	-	1.36	-	pF
Z	SOT1040AA1 impedance (915 MHz)	[1]	-	14.8-j128	-	Ω
Interface characteristics SOT 1040AB2 (Al strap)						
C_i	input capacitance	[1]	-	1.42	-	pF
Z	SOT1040AB2 impedance (915 MHz)	[1]	-	13.3-j122	-	Ω
Interface characteristics SOT1122						
C_i	input capacitance (parallel)	[1]	-	1.02	-	pF
Z	SOT1122 impedance (915 MHz)		-	18.6 - j171.2	-	Ω
Interface characteristics TSSOP8						
C_i	input capacitance (parallel)	[1]	-	1.16	-	pF
Z	TSSOP8 impedance (915 MHz)		-	16 - j148	-	Ω

[1] Measured with network analyzer at 915 MHz; values at 0.5 dBm after peak_{max} of on-set of die, measured in the center of the pads.

10. G2X Memory

According to EPCglobal the chip memory is organized in following memory sections:

Table 10. G2X memory sections

Name	Size	Bank
Reserved memory (32 bit ACCESS and 32 bit KILL password)	64 bit	00b
EPC (excluding 16 bit CRC-16 and 16 bit PC)	240 bit	01b
TID (including unique 32 bit serial number)	64 bit	10b
User memory (G2XM only)	512 bit	11b

The logical address of all memory banks begin at zero (00h).

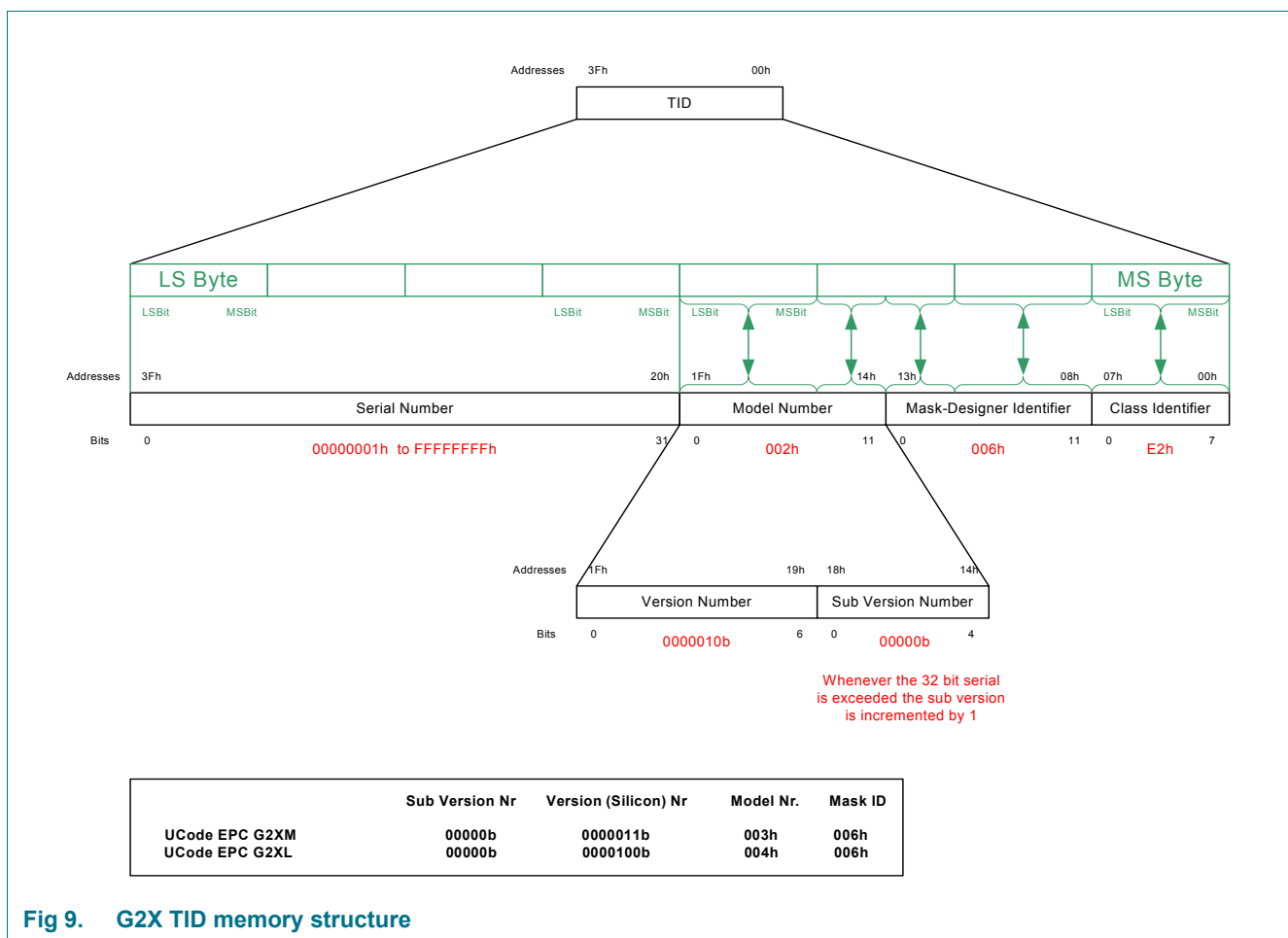

Fig 9. G2X TID memory structure

10.1 Memory map

Table 11. Memory map

Bank address	Memory address	Type	Content	Initial ^[1]	Remark
Bank 00	00h – 1Fh	Reserved	kill password:	all 00h	unlocked memory
	20h – 3Fh	Reserved	access password:	all 00h	unlocked memory
Bank 01	00h – 0Fh	EPC	CRC-16		memory mapped calculated CRC
	10h – 14h	EPC	Backscatter length	00110b	unlocked memory
	15h	EPC	Reserved for future use	0b	unlocked memory
	16h	EPC	Reserved for future use	0b	hardwired to 0
	17h – 1Fh	EPC	Numbering system indicator:	00h	unlocked memory
	20h – 10Fh	EPC	EPC	^[2]	unlocked memory
	Bank 10	00h – 07h	TID	allocation class identifier	1110 0010b
08h – 13h		TID	tag mask designer identifier:	0000 0000 0110b	locked memory
14h – 1Fh		TID	tag model number	TMNR	locked memory
20h – 3Fh		TID	serial number	SNR	locked memory
Bank 11 ^[3]	00h – 1FFh	User	user memory	undefined	unlocked memory

[1] This is the initial memory content when delivered by NXP Semiconductors

[2] G2XL: HEX 3005 FB63 AC1F 3841 EC88 0467
G2XM: HEX 3005 FB63 AC1F 3681 EC88 0468

[3] only G2XM

10.1.1 User memory (only G2XM)

The User Memory bank contains a sequential block of 512 bits (32 words of 16 bit) ranging from address 00h to 1Fh. The user memory can be accessed via Select, Read or Write command and it may be write locked, permanently write locked, unlocked or permanently unlocked.

In addition reading of not only of the User Memory but of the whole memory including EPC and TID can be protected by using the custom ReadProtect command.

11. Revision history

Table 12. Revision history

Document ID	Release date	Data sheet status	Change notice	Supersedes
157335	20091102	Product short data sheet		157334
Modifications:	<ul style="list-style-type: none"> Type SOT1122 added Figure 2 "Wafer layout and pinning information": correction of drawing 			
157334	20090805	Product short data sheet		157333
Modifications:	<ul style="list-style-type: none"> Table 8 "Wafer characteristics": value of memory characteristics modified Table 7 "TSSOP8 characteristics" and Table 8 "Interface characteristics": "Memory characteristics" removed 			
157333	20090617	Product short data sheet		157311
Modifications:	<ul style="list-style-type: none"> New type FCS2 Aluminum, SOT1040AB2 added Section 1 "General description": updated 			
157311	20080716	Product short data sheet		157310
Modifications:	<ul style="list-style-type: none"> added type "FCS2 Polymer Strap - SOT1040AA1" in added Figure 5 and 6 			
157310	20080627	Product short data sheet	-	-

12. Legal information

12.1 Data sheet status

Document status ^{[1][2]}	Product status ^[3]	Definition
Objective [short] data sheet	Development	This document contains data from the objective specification for product development.
Preliminary [short] data sheet	Qualification	This document contains data from the preliminary specification.
Product [short] data sheet	Production	This document contains the product specification.

[1] Please consult the most recently issued document before initiating or completing a design.

[2] The term 'short data sheet' is explained in section "Definitions".

[3] The product status of device(s) described in this document may have changed since this document was published and may differ in case of multiple devices. The latest product status information is available on the Internet at URL <http://www.nxp.com>.

12.2 Definitions

Draft — The document is a draft version only. The content is still under internal review and subject to formal approval, which may result in modifications or additions. NXP Semiconductors does not give any representations or warranties as to the accuracy or completeness of information included herein and shall have no liability for the consequences of use of such information.

Short data sheet — A short data sheet is an extract from a full data sheet with the same product type number(s) and title. A short data sheet is intended for quick reference only and should not be relied upon to contain detailed and full information. For detailed and full information see the relevant full data sheet, which is available on request via the local NXP Semiconductors sales office. In case of any inconsistency or conflict with the short data sheet, the full data sheet shall prevail.

12.3 Disclaimers

General — Information in this document is believed to be accurate and reliable. However, NXP Semiconductors does not give any representations or warranties, expressed or implied, as to the accuracy or completeness of such information and shall have no liability for the consequences of use of such information.

Right to make changes — NXP Semiconductors reserves the right to make changes to information published in this document, including without limitation specifications and product descriptions, at any time and without notice. This document supersedes and replaces all information supplied prior to the publication hereof.

Suitability for use — NXP Semiconductors products are not designed, authorized or warranted to be suitable for use in medical, military, aircraft, space or life support equipment, nor in applications where failure or malfunction of an NXP Semiconductors product can reasonably be expected to result in personal injury, death or severe property or environmental damage. NXP Semiconductors accepts no liability for inclusion and/or use of NXP Semiconductors products in such equipment or applications and therefore such inclusion and/or use is at the customer's own risk.

Applications — Applications that are described herein for any of these products are for illustrative purposes only. NXP Semiconductors makes no representation or warranty that such applications will be suitable for the specified use without further testing or modification.

Limiting values — Stress above one or more limiting values (as defined in the Absolute Maximum Ratings System of IEC 60134) may cause permanent damage to the device. Limiting values are stress ratings only and operation of the device at these or any other conditions above those given in the Characteristics sections of this document is not implied. Exposure to limiting values for extended periods may affect device reliability.

Terms and conditions of sale — NXP Semiconductors products are sold subject to the general terms and conditions of commercial sale, as published at <http://www.nxp.com/profile/terms>, including those pertaining to warranty, intellectual property rights infringement and limitation of liability, unless explicitly otherwise agreed to in writing by NXP Semiconductors. In case of any inconsistency or conflict between information in this document and such terms and conditions, the latter will prevail.

No offer to sell or license — Nothing in this document may be interpreted or construed as an offer to sell products that is open for acceptance or the grant, conveyance or implication of any license under any copyrights, patents or other industrial or intellectual property rights.

Export control — This document as well as the item(s) described herein may be subject to export control regulations. Export might require a prior authorization from national authorities.

Quick reference data — The Quick reference data is an extract of the product data given in the Limiting values and Characteristics sections of this document, and as such is not complete, exhaustive or legally binding.

12.4 Trademarks

Notice: All referenced brands, product names, service names and trademarks are the property of their respective owners.

UCODE — is a trademark of NXP B.V.

13. Contact information

For more information, please visit: <http://www.nxp.com>

For sales office addresses, please send an email to: salesaddresses@nxp.com

14. Tables

Table 1. Ordering information G2XM	4	Table 7. Limiting values ^{[1][2]}	14
Table 2. Ordering information G2XL	4	Table 8. Wafer characteristics	15
Table 3. Pin description of SOT1040-1	7	Table 9. Package interface characteristics	15
Table 4. Pin description of TSSOP8	8	Table 10. G2X memory sections	16
Table 5. Pin description of SOT1122	10	Table 11. Memory map	17
Table 6. SOT1122 Marking	10	Table 12. Revision history	18

15. Figures

Fig 1. Block diagram of G2X IC	5
Fig 2. Wafer layout and pinning information	6
Fig 3. Pinning - SOT1040-1	7
Fig 4. Package TSSOP8, SOT505-1	8
Fig 5. Package outline SOT1122	9
Fig 6. Package FCS2, SOT1040AA1, 12 μ m Cu metallization	11
Fig 7. Package FCS2, SOT1040AB2, 20 μ m Al metallization	12
Fig 8. Splicing drawing SOT1040-1	13
Fig 9. G2X TID memory structure	16

16. Contents

1 **General description** 1

1.1 Air interface standards 2

2 **Features** 3

2.1 Key features 3

2.2 Key benefits 3

2.3 Custom commands 3

3 **Applications** 4

4 **Ordering information** 4

5 **Block diagram** 5

6 **Wafer layout and pinning information** 6

6.1 Wafer layout 6

6.2 FCS2 layout strap and pinning 7

7 **Package outline** 8

8 **Limiting values** 14

9 **Characteristics** 15

9.1 Wafer characteristics 15

9.2 Package characteristics 15

10 **G2X Memory** 16

10.1 Memory map 17

10.1.1 User memory (only G2XM) 17

11 **Revision history** 18

12 **Legal information** 19

12.1 Data sheet status 19

12.2 Definitions 19

12.3 Disclaimers 19

12.4 Trademarks 19

13 **Contact information** 19

14 **Tables** 20

15 **Figures** 20

16 **Contents** 21

Please be aware that important notices concerning this document and the product(s) described herein, have been included in section 'Legal information'.



© NXP B.V. 2009. **All rights reserved.**
 For more information, please visit: <http://www.nxp.com>
 For sales office addresses, please send an email to: salesaddresses@nxp.com
 Date of release: 2 November 2009
 157335
 Document identifier: 157335