



LRIS2K

2048-bit EEPROM tag IC at 13.56 MHz, with 64-bit UID and Password, ISO15693 and ISO18000-3 Mode 1 compliant

Features

- ISO 15693 standard fully compliant
- ISO 18000-3 Mode 1 standard fully compliant
- 13.56 MHz \pm 7 kHz carrier frequency
- To tag: 10% or 100% ASK modulation using 1/4 (26 Kbit/s) or 1/256 (1.6 Kbit/s) pulse position coding
- From tag: Load modulation using Manchester coding with 423 kHz and 484 kHz subcarriers in Low (6.6 Kbit/s) or High (26 Kbit/s) data rate mode. Supports the 53 Kbit/s data rate with Fast commands
- Internal tuning capacitor 21 pF
- 1 000 000 Erase/Write cycles (minimum)
- 40 year data retention (minimum)
- 2048-bits EEPROM with Block Lock feature
- 64-bit unique identifier (UID)
- Electrical article surveillance (EAS) capable (software controlled)
- Kill function
- Multipassword protection
- Read & Write (block of 32 bits)
- 5 ms programming time

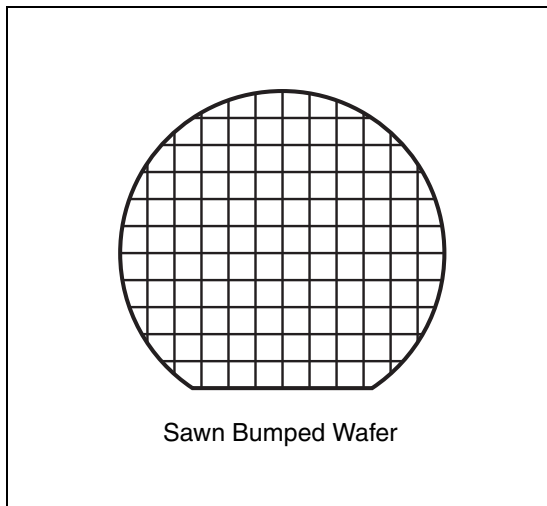

Contents

1	Description	11
1.1	Memory mapping	12
1.2	Commands	13
1.3	Initial dialogue for vicinity cards	14
1.3.1	Power transfer	14
1.3.2	Frequency	14
1.3.3	Operating field	14
2	LRIS2K block security	15
3	Example of LRIS2K security protection	17
4	Communication signal from VCD to LRIS2K	18
5	Data rate and data coding	20
5.1	Data coding mode: 1 out of 256	20
5.2	Data coding mode: 1 out of 4	22
5.3	VCD to LRIS2K frames	23
5.4	Start of frame (SOF)	23
6	Communications signal from LRIS2K to VCD	25
6.1	Load modulation	25
6.2	Subcarrier	25
6.3	Data rates	25
7	Bit representation and coding	26
7.1	Bit coding using one subcarrier	26
7.1.1	High data rate	26
7.1.2	Low data rate	27
7.2	Bit coding using two subcarriers	28
7.3	High data rate	28
7.4	Low data rate	28

8	LRIS2K to VCD frames	29
8.1	SOF when using one subcarrier	29
8.2	High data rate	29
8.3	Low data rate	30
8.4	SOF when using two subcarriers	31
8.5	High data rate	31
8.6	Low data rate	31
8.7	EOF when using one subcarrier	32
8.8	High data rate	32
8.9	Low data rate	32
8.10	EOF when using two subcarriers	33
8.11	High data rate	33
8.12	Low data rate	33
9	Unique identifier (UID)	34
10	Application family identifier (AFI)	35
11	Data storage format identifier (DSFID)	36
11.1	CRC	36
12	LRIS2K protocol description	37
13	LRIS2K states	39
13.1	Power-off state	39
13.2	Ready state	39
13.3	Quiet state	39
13.4	Selected state	39
14	Modes	41
14.1	Addressed mode	41
14.2	Non-addressed mode (general request)	41
14.3	Select mode	41
15	Request format	42

15.1	Request_flags	42
16	Response format	44
16.1	Response_flags	44
16.2	Response error code	45
17	Anticollision	46
17.1	Request parameters	46
18	Request processing by the LRIS2K	48
19	Explanation of the possible cases	49
20	Inventory Initiated command	51
21	Timing definition	52
21.1	t1: LRIS2K response delay	52
21.2	t2: VCD new request delay	52
21.3	t3: VCD new request delay in the absence of a response from the LRIS2K	52
22	Commands codes	53
23	Inventory	54
24	Stay Quiet	55
25	Read Single Block	56
26	Write Single Block	58
27	Lock Block	60
28	Select	62
29	Reset to Ready	63
30	Write AFI	64

31	Lock AFI	66
32	Write DSFID	67
33	Lock DSFID	69
34	Get System Info	70
35	Get Multiple Block Security Status	72
36	Kill	74
37	Write Password	76
38	Lock Password	78
39	Present Password	80
40	Fast Read Single Block	82
41	Fast Inventory Initiated	84
42	Fast Initiate	85
43	Inventory Initiated	86
44	Initiate	87
45	Maximum rating	88
46	DC and AC parameters	89
47	Part numbering	91
Appendix A Anticollision algorithm (Informative)		92
A.1	Algorithm for pulsed slots	92
Appendix B CRC (informative)		93
B.1	CRC error detection method	93

B.2 CRC calculation example	93
Appendix C Application family identifier (AFI) (informative)	95
Revision history	96

List of tables

Table 1.	Signal names	11
Table 2.	Memory map	12
Table 3.	Memory blocks with protect status area	15
Table 4.	Protect status area organization	15
Table 5.	Read / Write protection bit setting and block protection status	15
Table 6.	Password system area	16
Table 7.	LRIS2K block security protection after power-up	17
Table 8.	LRIS2K block security protection after a valid presentation of password 1	17
Table 9.	10% modulation parameters	18
Table 10.	Response data rates	25
Table 11.	UID format	34
Table 12.	CRC transmission rules	36
Table 13.	VCD request frame format	37
Table 14.	LRIS2K response frame format	37
Table 15.	LRIS2K response depending on Request_flags	40
Table 16.	General request format	42
Table 17.	Definition of request_flags 1 to 4	42
Table 18.	Request_flags 5 to 8 when Bit 3 = 0	43
Table 19.	Request_flags 5 to 8 when Bit 3 = 1	43
Table 20.	General response format	44
Table 21.	Definitions of response_flags 1 to 8	44
Table 22.	Response error code definition	45
Table 23.	Inventory request format	46
Table 24.	Example of the addition of 0-bits to an 11-bit mask value	46
Table 25.	Timing values	52
Table 26.	Command codes	53
Table 27.	Inventory request format	54
Table 28.	Inventory response format	54
Table 29.	Stay Quiet request format	55
Table 30.	Read Single Block request format	56
Table 31.	Read Single Block response format when Error_flag is NOT set	56
Table 32.	Block Locking status	56
Table 33.	Read Single Block response format when Error_flag is set	56
Table 34.	Write Single Block request format	58
Table 35.	Write Single Block response format when Error_flag is NOT set	58
Table 36.	Write Single Block response format when Error_flag is set	58
Table 37.	Lock Single Block request format	60
Table 38.	Lock Block response format when Error_flag is NOT set	60
Table 39.	Lock Block response format when Error_flag is set	60
Table 40.	Select request format	62
Table 41.	Select Block response format when Error_flag is NOT set	62
Table 42.	Select response format when Error_flag is set	62
Table 43.	Reset to Ready request format	63
Table 44.	Reset to Ready response format when Error_flag is NOT set	63
Table 45.	Reset to Ready request format when Error_flag is set	63
Table 46.	Write AFI request format	64
Table 47.	Write AFI response format when Error_flag is NOT set	64
Table 48.	Write AFI response format when Error_flag is set	64

Table 49.	Lock AFI request format	66
Table 50.	Lock AFI response format when Error_flag is NOT set	66
Table 51.	Lock AFI response format when Error_flag is set.	66
Table 52.	Write DSFID request format	67
Table 53.	Write DSFID response format when Error_flag is NOT set	67
Table 54.	Write DSFID response format when Error_flag is set.	67
Table 55.	Lock DSFID request format	69
Table 56.	Lock DSFID response format when Error_flag is NOT set.	69
Table 57.	Lock DSFID response format when Error_flag is set	69
Table 58.	Get System Info request format	70
Table 59.	Get System Info response format when Error_flag is NOT set.	70
Table 60.	Get System Info response format when Error_flag is set	70
Table 61.	Get Multiple Block Security Status request format	72
Table 62.	Get Multiple Block Security Status response format when Error_flag is NOT set	72
Table 63.	Block Locking status	72
Table 64.	Get Multiple Block Security Status response format when Error_flag is set.	72
Table 65.	Kill request format.	74
Table 66.	Kill response format when Error_flag is NOT set	74
Table 67.	Kill response format when Error_flag is set	74
Table 68.	Write Password request format	76
Table 69.	Write Password response format when Error_flag is NOT set	76
Table 70.	Write Password response format when Error_flag is set	76
Table 71.	Lock Password request format	78
Table 72.	Protect status	78
Table 73.	Lock Password response format when Error_flag is NOT set	78
Table 74.	Lock Password response format when Error_flag is set.	78
Table 75.	Present Password request format	80
Table 76.	Present Password response format when Error_flag is NOT set	80
Table 77.	Present Password response format when Error_flag is set	80
Table 78.	Fast Read Single Block request format	82
Table 79.	Fast Read Single Block response format when Error_flag is NOT set.	82
Table 80.	Block Locking status	82
Table 81.	Fast Read Single Block response format when Error_flag is set	82
Table 82.	Fast Inventory Initiated request format	84
Table 83.	Fast Inventory Initiated response format	84
Table 84.	Fast Initiate request format	85
Table 85.	Fast Initiate response format	85
Table 86.	Inventory Initiated request format	86
Table 87.	Inventory Initiated response format	86
Table 88.	Initiate request format.	87
Table 89.	Initiate Initiated response format.	87
Table 90.	Absolute maximum ratings	88
Table 91.	AC characteristics	89
Table 92.	DC characteristics.	90
Table 93.	Operating conditions.	90
Table 94.	Ordering information scheme	91
Table 95.	CRC definition.	93
Table 96.	AFI coding.	95
Table 97.	Document revision history	96

List of figures

Figure 1.	Pad connections	11
Figure 2.	100% modulation waveform	18
Figure 3.	10% modulation waveform	19
Figure 4.	1 out of 256 coding mode	20
Figure 5.	Detail of a time period	21
Figure 6.	1 out of 4 coding mode	22
Figure 7.	1 out of 4 coding example	22
Figure 8.	SOF to select 1 out of 256 data coding mode	23
Figure 9.	SOF to select 1 out of 4 data coding mode	23
Figure 10.	EOF for either data coding mode	24
Figure 11.	Logic 0, high data rate	26
Figure 12.	Logic 0, high data rate x2	26
Figure 13.	Logic 1, high data rate	26
Figure 14.	Logic 1, high data rate x2	26
Figure 15.	Logic 0, low data rate	27
Figure 16.	Logic 0, low data rate x2	27
Figure 17.	Logic 1, low data rate	27
Figure 18.	Logic 1, low data rate x2	27
Figure 19.	Logic 0, high data rate	28
Figure 20.	Logic 1, high data rate	28
Figure 21.	Logic 0, low data rate	28
Figure 22.	Logic 1, low data rate	28
Figure 23.	Start of frame, high data rate, one subcarrier	29
Figure 24.	Start of frame, high data rate, one subcarrier x2	29
Figure 25.	Start of frame, low data rate, one subcarrier	30
Figure 26.	Start of frame, low data rate, one subcarrier x2	30
Figure 27.	Start of frame, high data rate, two subcarriers	31
Figure 28.	Start of frame, low data rate, two subcarriers	31
Figure 29.	End of frame, high data rate, one subcarriers	32
Figure 30.	End of frame, high data rate, one subcarriers x2	32
Figure 31.	End of frame, low data rate, one subcarriers	32
Figure 32.	End of frame, low data rate, one subcarriers x2	32
Figure 33.	End of frame, high data rate, two subcarriers	33
Figure 34.	End of frame, low data rate, two subcarriers	33
Figure 35.	LRIS2K decision tree for AFI	35
Figure 36.	LRIS2K protocol timing	38
Figure 37.	LRIS2K state transition diagram	40
Figure 38.	Principle of comparison between the mask, the slot number and the UID	47
Figure 39.	Description of a possible anticollision sequence	50
Figure 40.	Stay Quiet frame exchange between VCD and LRIS2K	55
Figure 41.	Read Single Block frame exchange between VCD and LRIS2K	57
Figure 42.	Write Single Block frame exchange between VCD and LRIS2K	59
Figure 43.	Lock Block frame exchange between VCD and LRIS2K	61
Figure 44.	Select frame exchange between VCD and LRIS2K	62
Figure 45.	Reset to Ready frame exchange between VCD and LRIS2K	63
Figure 46.	Write AFI frame exchange between VCD and LRIS2K	65
Figure 47.	Lock AFI frame exchange between VCD and LRIS2K	66
Figure 48.	Write DSFID frame exchange between VCD and LRIS2K	68

Figure 49.	Lock DSFID frame exchange between VCD and LRIS2K	69
Figure 50.	Get System Info frame exchange between VCD and LRIS2K	71
Figure 51.	Get Multiple Block Security Status frame exchange between VCD and LRIS2K	73
Figure 52.	Kill frame exchange between VCD and LRIS2K	75
Figure 53.	Write Password frame exchange between VCD and LRIS2K	77
Figure 54.	Lock Password frame exchange between VCD and LRIS2K	79
Figure 55.	Present Password frame exchange between VCD and LRIS2K	81
Figure 56.	Fast Read Single Block frame exchange between VCD and LRIS2K	83
Figure 57.	Fast Initiate frame exchange between VCD and LRIS2K	85
Figure 58.	Initiate frame exchange between VCD and LRIS2K	87
Figure 59.	LRIS2K synchronous timing, transmit and receive	90

1 Description

The LRIS2K is a contactless memory powered by the received carrier electromagnetic wave. It is a 2048-bit electrically erasable programmable memory (EEPROM). The memory is organized as 64 blocks of 32 bits. The LRIS2K is accessed via the 13.56 MHz carrier electromagnetic wave on which incoming data are demodulated from the received signal amplitude modulation (ASK: amplitude shift keying). The received ASK wave is 10% or 100% modulated with a data rate of 1.6 Kbit/s using the 1/256 pulse coding mode or a Data rate of 26 Kbit/s using the 1/4 pulse coding mode.

Outgoing data are generated by the LRIS2K load variation using Manchester coding with one or two subcarrier frequencies at 423 KHz and 484 kHz. Data are transferred from the LRIS2K at 6.6 Kbit/s in low data rate mode and 26 Kbit/s high data rate mode. The LRIS2K supports the 53 Kbit/s in high data rate mode in one subcarrier frequency at 423 kHz.

The LRIS2K follows the ISO 15693 recommendation for radio frequency power and signal interface.

Figure 1. Pad connections

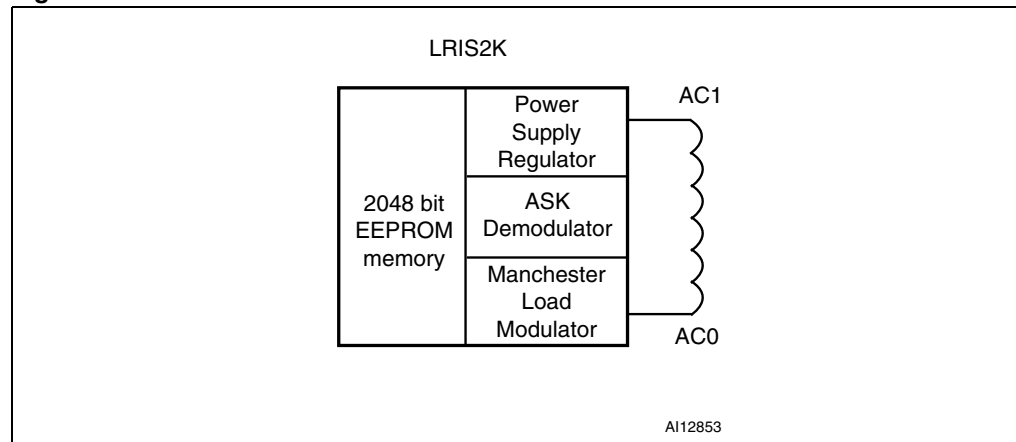

Table 1. Signal names

Signal name	Function
AC1	Antenna coil
AC0	Antenna coil

1.1 Memory mapping

The LRIS2K is divided into 64 blocks of 32 bits as shown in [Table 2](#). Each block can be individually read- and/or write-protected using a specific lock or password command.

The user area consists of blocks that are always accessible. Read and Write operations are possible if the addressed block is not protected. During a Write, the 32 bits of the block are replaced by the new 32-bit value.

The LRIS2K also has a 64-bit block that is used to store the 64-bit unique identifier (UID). The UID is compliant with the ISO 15963 description, and its value is used during the anticollision sequence (Inventory). This block is not accessible by the user and its value is written by ST on the production line.

The LRIS2K also includes an AFI register in which the application family identifier is stored, and a DSFID register in which the data storage family identifier used in the anticollision algorithm is stored. The LRIS2K has four additional 32-bit blocks in which the Kill code and the password codes are stored.

Table 2. Memory map

Add	0	7	8	15	16	23	24	31	Protect status
0	User area								5 bits
1	User area								5 bits
2	User area								5 bits
3	User area								5 bits
4	User area								5 bits
5	User area								5 bits
6	User area								5 bits
7	User area								5 bits
8	User area								5 bits
...
60	User area								5 bits
61	User area								5 bits
62	User area								5 bits
63	User area								5 bits
	UID 0		UID 1		UID 2		UID 3		
	UID 4		UID 5		UID 6		UID 7		
	AFI		DSFID						
0 ⁽¹⁾	Kill code								5 bits
1 ⁽¹⁾	Password code 1								5 bits
2 ⁽¹⁾	Password code 2								5 bits
3 ⁽¹⁾	Password code 3								5 bits

1. RFU bit (b8) of Request_flag set to 1.

1.2 Commands

The LRIS2K supports the following commands:

- **Inventory**, used to perform the anticollision sequence.
- **Stay Quiet**, used to put the LRIS2K in quiet mode, where it does not respond to any inventory command.
- **Select**, used to select the LRIS2K. After this command, the LRIS2K processes all Read/Write commands with Select_flag set.
- **Reset To Ready**, used to put the LRIS2K in the ready state.
- **Read Block**, used to output the 32 bits of the selected block and its locking status.
- **Write Block**, used to write the 32-bit value in the selected block, provided that it is not locked.
- **Lock Block**, used to lock the selected block. After this command, the block cannot be modified.
- **Write AFI**, used to write the 8-bit value in the AFI register.
- **Lock AFI**, used to lock the AFI register.
- **Write DSFID**, used to write the 8-bit value in the DSFID register.
- **Lock DSFID**, used to lock the DSFID register.
- **Get System Info**, used to provide the system information value
- **Get Multiple Block Security Status**, used to send the security status of the selected block.
- **Initiate**, used to trigger the tag response to the Inventory Initiated sequence.
- **Inventory Initiated**, used to perform the anticollision sequence triggered by the Initiate command.
- **Kill**, used to definitively deactivate the tag.
- **Write Password**, used to write the 32 bits of the selected password.
- **Lock Password**, used to write the Protect Status bits of the selected block.
- **Present Password**, enables the user to present a password to unprotect the user blocks linked to this password.
- **Fast Initiate**, used to trigger the tag response to the Inventory Initiated sequence.
- **Fast Inventory Initiated**, used to perform the anticollision sequence triggered by the Initiate command.
- **Fast Read Single Block**, used to output the 32 bits of the selected block and its locking status.

1.3 Initial dialogue for vicinity cards

The dialog between the vicinity coupling device (VCD) and the vicinity integrated circuit Card or VICC (LRIS2K) takes place as follows:

- activation of the LRIS2K by the RF operating field of the VCD.
- transmission of a command by the VCD.
- transmission of a response by the LRIS2K.

These operations use the RF power transfer and communication signal interface described below (see [Power transfer](#), [Frequency](#) and [Operating field](#)). This technique is called RTF (Reader Talk First).

1.3.1 Power transfer

Power is transferred to the LRIS2K by radio frequency at 13.56 MHz via coupling antennas in the LRIS2K and the VCD. The RF operating field of the VCD is transformed on the LRIS2K antenna to an AC Voltage which is rectified, filtered and internally regulated. The amplitude modulation (ASK) on this received signal is demodulated by the ASK demodulator.

1.3.2 Frequency

The ISO 15693 standard defines the carrier frequency (f_C) of the operating field as 13.56 MHz \pm 7 kHz.

1.3.3 Operating field

The LRIS2K operates continuously between H_{\min} and H_{\max} .

- The minimum operating field is H_{\min} and has a value of 150 mA/m rms.
- The maximum operating field is H_{\max} and has a value of 5 A/m rms.

A VCD shall generate a field of at least H_{\min} and not exceeding H_{\max} in the operating volume.

2 LRIS2K block security

The LRIS2K provides a special protection mechanism based on passwords. Each memory block of the LRIS2K can be individually protected by one out of three available passwords, and each block can also have Read/Write access conditions set.

Each memory block of the LRIS2K is assigned with a Protect Status area including a Block Lock bit, two Password Control bits and two Read/Write protection bits as shown in [Table 4](#). [Table 4](#) describes the organization of the Protect status area which can be read using the Read Single Block command with the Option_flag set to '1', and the Get Multiple Block Security status command.

Table 3. Memory blocks with protect status area

Add	0	7	8	15	16	23	24	31	Protect status
0	User area								5 bits
1	User area								5 bits
...	User area								5 bits

Table 4. Protect status area organization

b ₇	b ₆	b ₅	b ₄	b ₃	b ₂	b ₁	b ₀
0	0	0	Password Control bits		Read / Write protection bits		Block Lock

When the Block Lock bit is set to '1', for instance by issuing a Block Lock command, the 2 Read/Write protection bits (b₁, b₂) are used to set the Read/Write access of the block as described in [Table 5](#).

The next 2 bits of the Protect Status area (b₃, b₄) are the Password Control bits. The value of these two bits is used to link a password to the block as defined in [Table 5](#).

Combinations not described in [Table 5](#) are reserved.

Table 5. Read / Write protection bit setting and block protection status

Block lock function		Password Control bits	Block access when password presented		Block access when password not presented		Block protection status
b ₀	b ₂ , b ₁	b ₄ , b ₃					
0	00	00	Not applicable		READ	WRITE	the block is not protected
1	11	01	READ	NO WRITE	NO READ	NO WRITE	the block is protected by password 1
1	11	10	READ	NO WRITE	NO READ	NO WRITE	the block is protected by password 2
1	11	11	READ	NO WRITE	NO READ	NO WRITE	the block is protected by password 3
1	00	00	Not applicable		READ	NO WRITE	the block is not protected by a password

The LRIS2K password protection is organized around a dedicated set of commands plus a system area of four password blocks where the password values and the Kill code are stored. Each password block also has a Protect Status area, making it possible to set the Read / Write access right of each individual block. This system area is described in [Table 6](#).

Table 6. Password system area

Add	0	7	8	15	16	23	24	31	Protect status
0	Kill code								5 bits
1	Password 1								5 bits
2	Password 2								5 bits
3	Password 3								5 bits

The dedicated password commands are:

- **Write Password:**

The Write Password command is used to write a 32-bit block into the password system area. This command must be used to write or update password values and to set the kill code. Depending on the Read/Write access set in the Protect Status area, it is possible to modify a password value after issuing a valid Present Password command.

- **Lock Password:**

The Lock Password command is used to set the Protect Status area of the selected block. Bits b_4 to b_1 of the Protect Status are affected by the Lock Password command. The Block Lock bit, b_0 , is set to '1' automatically. After issuing a Lock Password command, the protection settings of the selected block are activated. The protection of a locked block cannot be changed. A Lock Password command sent to a locked block returns an error code.

The Lock Password command is also used to set the Protect Status areas of the password blocks. RFU bit 8 of the Request_flag is used to select either the memory area (bit 8 = '0') or the password area (bit 8 = '1').

- **Present Password:**

The Present Password command is used to present one of the three passwords to the LRIS2K in order to modify the access rights of all the memory blocks linked to that password ([Table 5](#)) including the password itself. If the presented password is correct, the access rights remain activated until the tag is powered off or until a new Present Password command is issued.

3 Example of LRIS2K security protection

[Table 7](#) and [Table 8](#) show the block security protections before and after a valid Present Password command. The [Table 7](#) shows blocks access rights of an LRIS2K after power-up. After a valid Present Password command with password 1, the memory block access is changed as given in [Table 8](#).

Table 7. LRIS2K block security protection after power-up

Add						Protect status					
	0	7 8	15 16	23 24	31	b ₇ b ₆ b ₅	b ₄	b ₃	b ₂	b ₁	b ₀
0	Protection: Standard,		Read	- No Write		xxx	0	0	0	0	1
4	Protection: Pswd 1,		No Read	- No Write		xxx	0	1	1	1	1

Table 8. LRIS2K block security protection after a valid presentation of password 1

Add						Protect status					
	0	7 8	15 16	23 24	31	b ₇ b ₆ b ₅	b ₄	b ₃	b ₂	b ₁	b ₀
0	Protection: Standard,		Read	- No Write		xxx	0	0	0	0	1
4	Protection: Pswd 1,		Read	- No Write		xxx	0	1	1	1	1

4 Communication signal from VCD to LRIS2K

Communications between the VCD and the LRIS2K takes place using the modulation principle of ASK (Amplitude Shift Keying). Two modulation indexes are used, 10% and 100%. The LRIS2K decodes both. The VCD determines which index is used.

The modulation index is defined as $[a - b]/[a + b]$ where a is the peak signal amplitude and b , the minimum signal amplitude of the carrier frequency.

Depending on the choice made by the VCD, a "pause" will be created as described in [Figure 2](#) and [Figure 3](#).

The LRIS2K is operational for any degree of modulation index from between 10% and 30%.

Figure 2. 100% modulation waveform

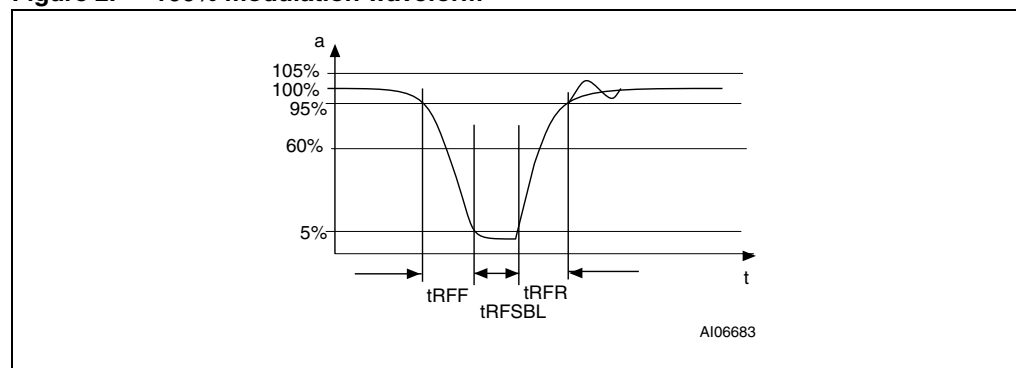

Table 9. 10% modulation parameters

Symbol	Parameter definition	Value
hr	$0.1 \times (a - b)$	max
hf	$0.1 \times (a - b)$	max

Figure 3. 10% modulation waveform

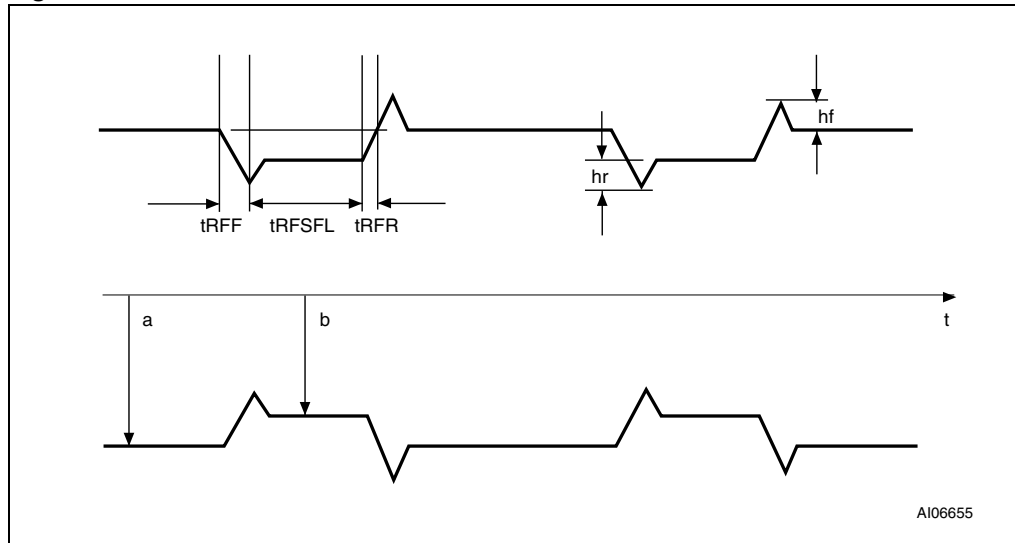
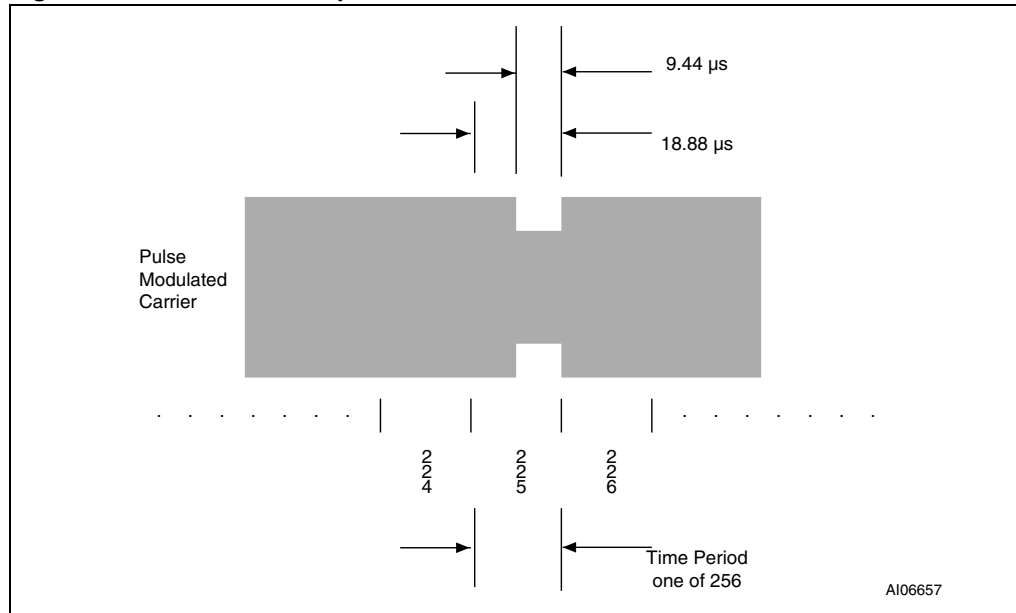

Figure 5. Detail of a time period



5.2 Data coding mode: 1 out of 4

The value of 2 bits is represented by the position of one pause. The position of the pause on 1 of 4 successive time periods of $18.88 \mu\text{s}$ ($256/f_C$), determines the value of the 2 bits. Four successive pairs of bits form a byte, where the least significant pair of bits is transmitted first.

In this case the transmission of one byte takes $302.08 \mu\text{s}$ and the resulting data rate is 26.48 Kbits/s ($f_C/512$). *Figure 6* illustrates the 1 out of 4 pulse position technique and coding. *Figure 7* shows the transmission of E1h (225d - 1110 0001b) by the VCD.

Figure 6. 1 out of 4 coding mode

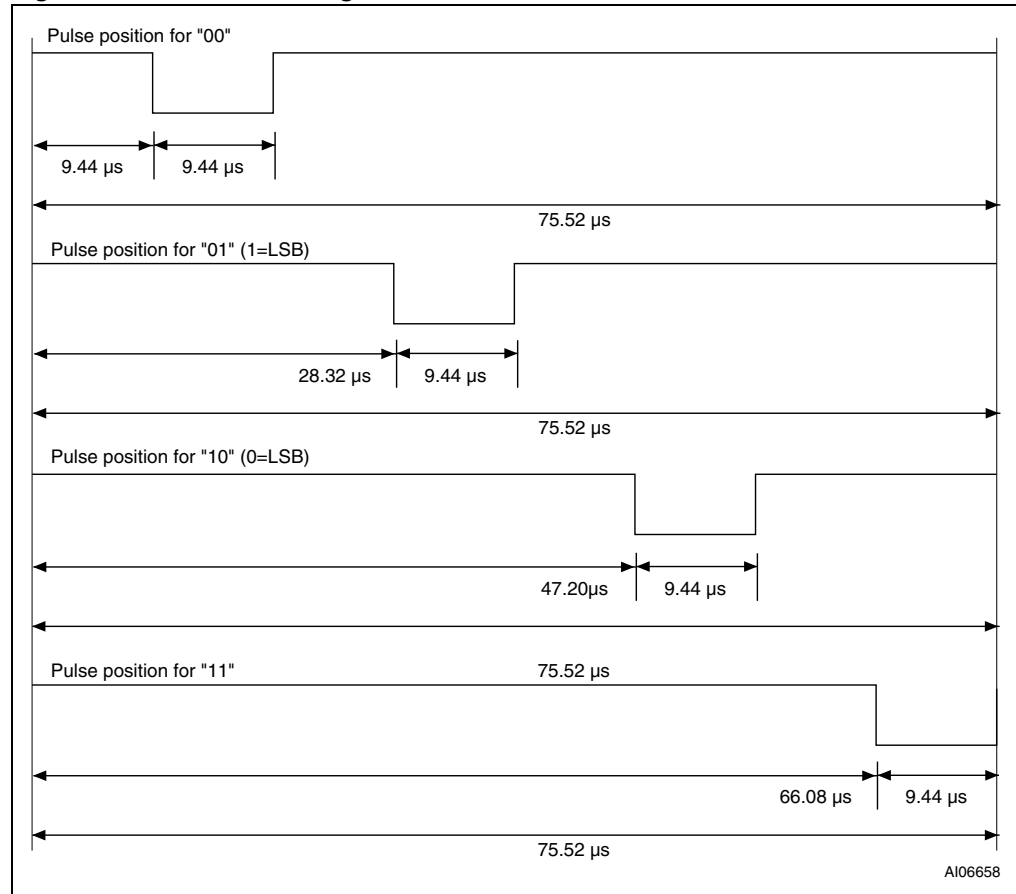
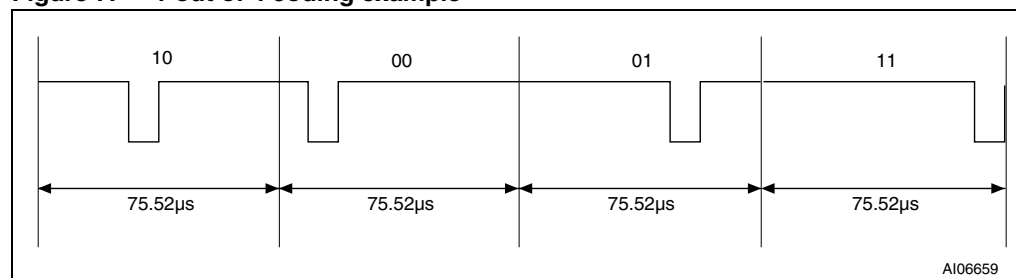

Figure 7. 1 out of 4 coding example



5.3 VCD to LRIS2K frames

Frames are delimited by a start of frame (SOF) and an end of frame (EOF). They are implemented using code violation. Unused options are reserved for future use.

The LRIS2K is ready to receive a new command frame from the VCD 311.5 μs (t_2) after sending a response frame to the VCD.

The LRIS2K takes a power-up time of 0.1 ms after being activated by the powering field. After this delay, the LRIS2K is ready to receive a command frame from the VCD.

5.4 Start of frame (SOF)

The SOF defines the data coding mode the VCD is to use for the following command frame. The SOF sequence described in [Figure 8](#) selects the 1 out of 256 data coding mode. The SOF sequence described in [Figure 9](#) selects the 1 out of 4 data coding mode. The EOF sequence for either coding mode is described in [Figure 10](#).

Figure 8. SOF to select 1 out of 256 data coding mode

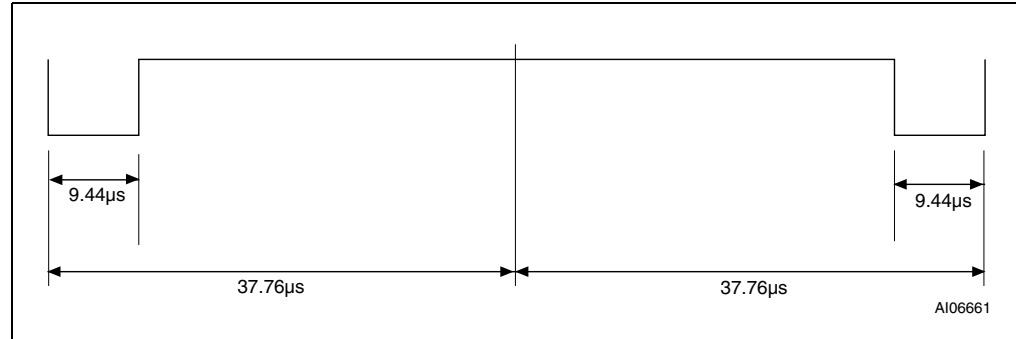

Figure 9. SOF to select 1 out of 4 data coding mode

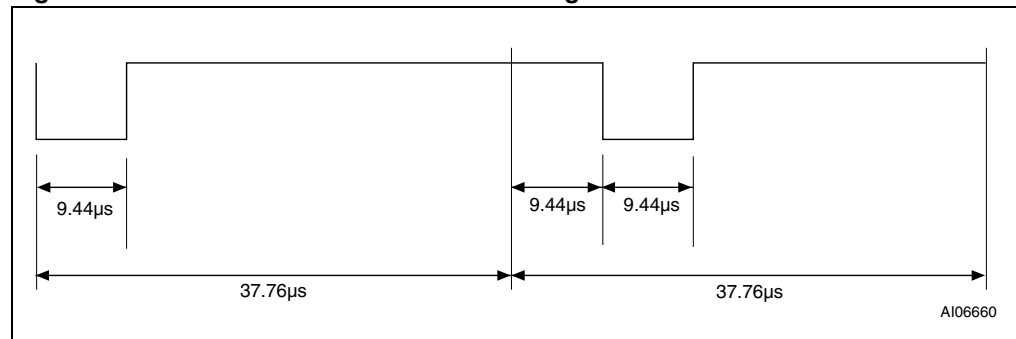
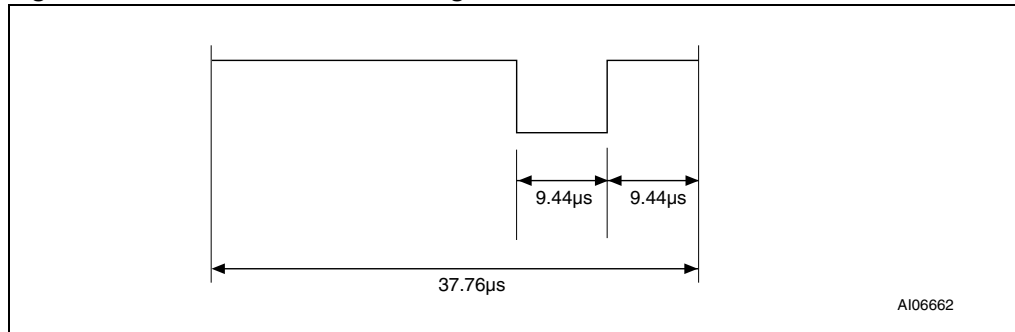

Figure 10. EOF for either data coding mode



6 Communications signal from LRIS2K to VCD

The LRIS2K has several modes defined for some parameters, owing to which it can operate in different noise environments and meet different application requirements.

6.1 Load modulation

The LRIS2K is capable of communication to the VCD via an inductive coupling area whereby the carrier is loaded to generate a subcarrier with frequency f_S . The subcarrier is generated by switching a load in the LRIS2K.

The load-modulated amplitude received on the VCD antenna must be of at least 10mV when measured as described in the test methods defined in International Standard ISO10373-7.

6.2 Subcarrier

The LRIS2K supports the one-subcarrier and two-subcarrier response formats. These formats are selected by the VCD using the first bit in the protocol header. When one subcarrier is used, the frequency f_{S1} of the subcarrier load modulation is 423.75 kHz ($f_C/32$). When two subcarriers are used, the frequency f_{S1} is 423.75 kHz ($f_C/32$), and frequency f_{S2} is 484.28 kHz ($f_C/28$). When using the two-subcarrier mode, the LRIS2K generates a continuous phase relationship between f_{S1} and f_{S2} .

6.3 Data rates

The LRIS2K can respond using the low or the high data rate format. The selection of the data rate is made by the VCD using the second bit in the protocol header. It also supports the x2 mode available on all the Fast commands. [Table 10](#) shows the different data rates produced by the LRIS2K using the different response format combinations.

Table 10. Response data rates

Data rate		One subcarrier	Two subcarriers
Low	Standard commands	6.62 Kbits/s ($f_C/2048$)	6.67 Kbits/s ($f_C/2032$)
	Fast commands	13.24 Kbits/s ($f_C/1024$)	not applicable
High	Standard commands	26.48 Kbits/s ($f_C/512$)	26.69 Kbits/s ($f_C/508$)
	Fast commands	52.97 Kbits/s ($f_C/256$)	not applicable

7 Bit representation and coding

Data bits are encoded using Manchester coding, according to the following schemes. For the low data rate, same subcarrier frequency or frequencies is/are used, in this case the number of pulses is multiplied by 4 and all times will increase by this factor. For the Fast commands using one subcarrier, all pulse numbers and times are divided by 2.

7.1 Bit coding using one subcarrier

7.1.1 High data rate

A logic 0 starts with 8 pulses at 423.75 kHz ($f_C/32$) followed by an unmodulated time of 18.88 μs as shown in [Figure 11](#).

Figure 11. Logic 0, high data rate

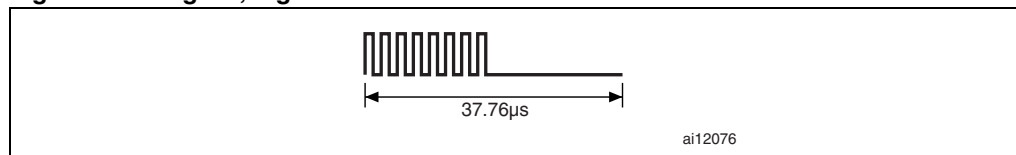

For the fast commands, a logic 0 starts with 4 pulses at 423.75 kHz ($f_C/32$) followed by an unmodulated time of 9.44 μs as shown in [Figure 12](#).

Figure 12. Logic 0, high data rate x2

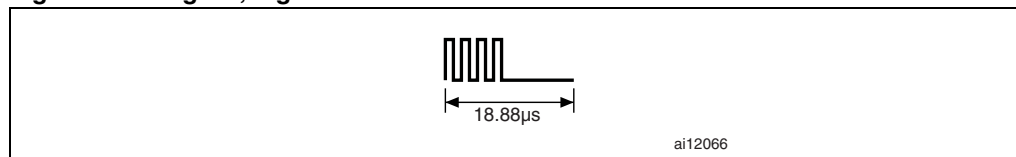

A logic 1 starts with an unmodulated time of 18.88 μs followed by 8 pulses at 423.75 kHz ($f_C/32$) as shown in [Figure 13](#).

Figure 13. Logic 1, high data rate

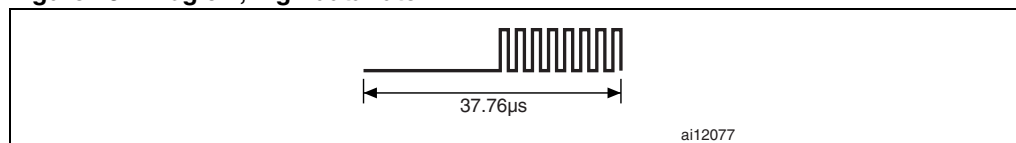

For the Fast commands, a logic 1 starts with an unmodulated time of 9.44 μs followed by 4 pulses of 423.75 kHz ($f_C/32$) as shown in [Figure 14](#).

Figure 14. Logic 1, high data rate x2



7.1.2 Low data rate

A logic 0 starts with 32 pulses at 423.75 kHz ($f_C/32$) followed by an unmodulated time of 75.52 μs as shown in [Figure 15](#).

Figure 15. Logic 0, low data rate

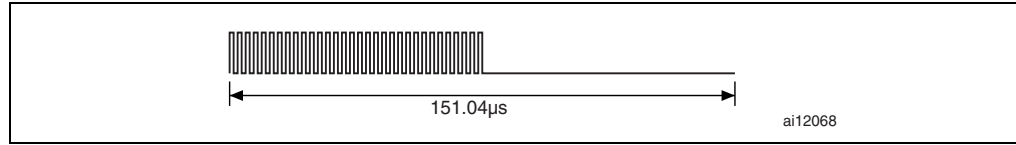

For the Fast commands, a logic 0 starts with 16 pulses at 423.75 kHz ($f_C/32$) followed by an unmodulated time of 37.76 μs as shown in [Figure 16](#).

Figure 16. Logic 0, low data rate x2

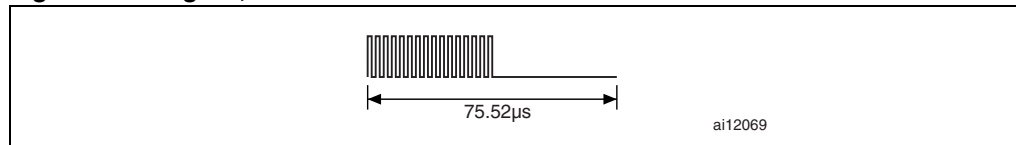

A logic 1 starts with an unmodulated time of 75.52 μs followed by 32 pulses at 423.75 kHz ($f_C/32$) as shown in [Figure 17](#).

Figure 17. Logic 1, low data rate

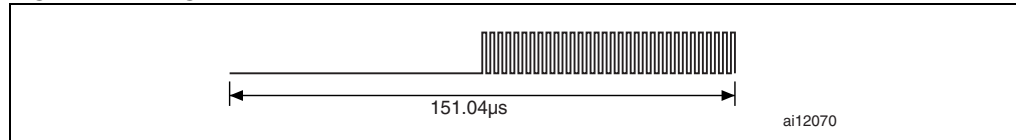

For the Fast commands, a logic 1 starts with an unmodulated time of 37.76 μs followed by 16 pulses at 423.75 kHz ($f_C/32$) as shown in [Figure 17](#).

Figure 18. Logic 1, low data rate x2

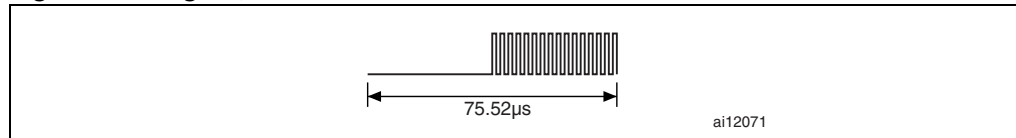

7.2 Bit coding using two subcarriers

7.3 High data rate

A logic 0 starts with 8 pulses at 423.75 kHz ($f_C/32$) followed by 9 pulses at 484.28 kHz ($f_C/28$) as shown in [Figure 19](#). For the Fast commands, the x2 mode is not available.

Figure 19. Logic 0, high data rate

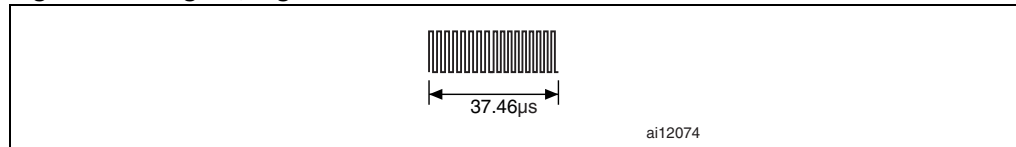

A logic 1 starts with 9 pulses at 484.28 kHz ($f_C/28$) followed by 8 pulses at 423.75 kHz ($f_C/32$) as shown in [Figure 20](#). For the Fast commands, the x2 mode is not available.

Figure 20. Logic 1, high data rate

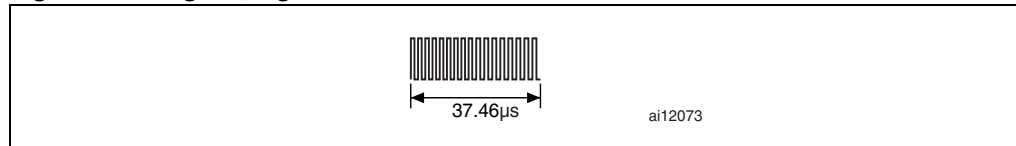

7.4 Low data rate

A logic 0 starts with 32 pulses at 423.75 kHz ($f_C/32$) followed by 36 pulses at 484.28 kHz ($f_C/28$) as shown in [Figure 21](#). For the Fast commands, the x2 mode is not available.

Figure 21. Logic 0, low data rate

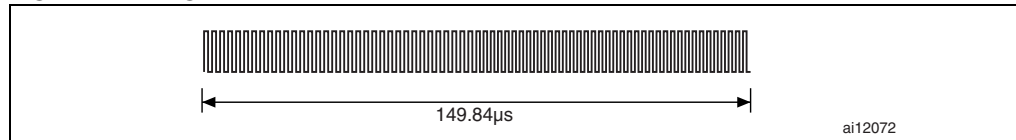

A logic 1 starts with 36 pulses at 484.28 kHz ($f_C/28$) followed by 32 pulses at 423.75 kHz ($f_C/32$) as shown in [Figure 22](#). For the Fast commands, the x2 mode is not available.

Figure 22. Logic 1, low data rate

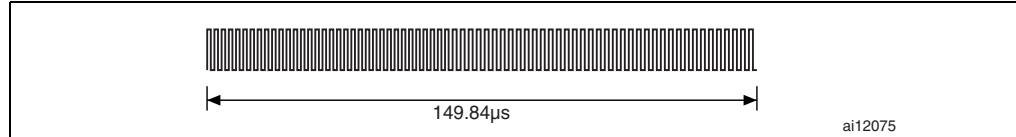

8 LRIS2K to VCD frames

Frames are delimited by an SOF and an EOF. They are implemented using code violation. Unused options are reserved for future use. For the low data rate, the same subcarrier frequency or frequencies is/are used. In this case the number of pulses is multiplied by 4. For the Fast commands using one subcarrier, all pulse numbers and times are divided by 2.

8.1 SOF when using one subcarrier

8.2 High data rate

The SOF includes an unmodulated time of 56.64 μs , followed by 24 pulses at 423.75 kHz ($f_C/32$), and a logic 1 that consists of an unmodulated time of 18.88 μs followed by 8 pulses at 423.75 kHz as shown in [Figure 23](#).

Figure 23. Start of frame, high data rate, one subcarrier

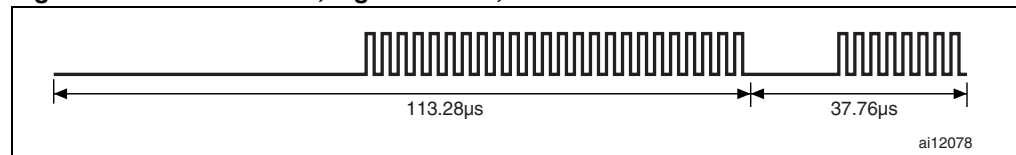

For the Fast commands, the SOF comprises an unmodulated time of 28.32 μs , followed by 12 pulses at 423.75 kHz ($f_C/32$), and a logic 1 that consists of an unmodulated time of 9.44 μs followed by 4 pulses at 423.75 kHz as shown in [Figure 24](#).

Figure 24. Start of frame, high data rate, one subcarrier x2

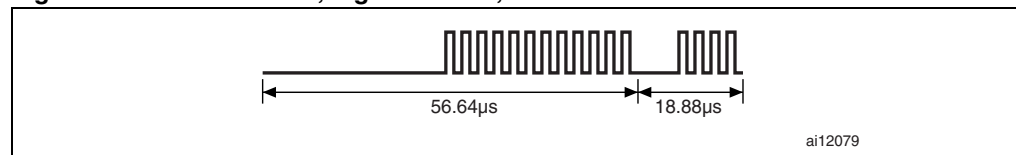

8.3 Low data rate

The SOF comprises an unmodulated time of 226.56 μs , followed by 96 pulses at 423.75 kHz ($f_D/32$), and a logic 1 that consists of an unmodulated time of 75.52 μs followed by 32 pulses at 423.75 kHz as shown in [Figure 25](#).

Figure 25. Start of frame, low data rate, one subcarrier

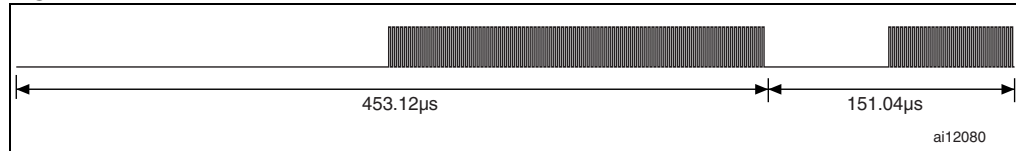

For the Fast commands, the SOF comprises an unmodulated time of 113.28 μs , followed by 48 pulses at 423.75 kHz ($f_D/32$), and a logic 1 that includes an unmodulated time of 37.76 μs followed by 16 pulses at 423.75 kHz as shown in [Figure 26](#).

Figure 26. Start of frame, low data rate, one subcarrier x2

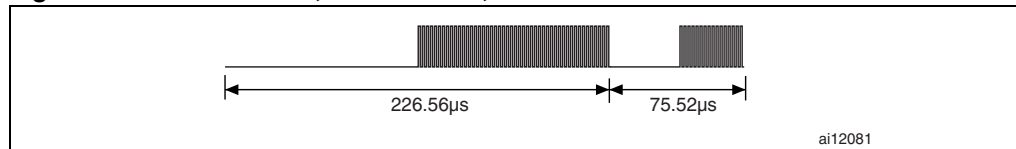

8.4 SOF when using two subcarriers

8.5 High data rate

The SOF comprises 27 pulses at 484.28 kHz ($f_C/28$), followed by 24 pulses at 423.75 kHz ($f_C/32$), and a logic 1 that includes 9 pulses at 484.28 kHz followed by 8 pulses at 423.75 kHz as shown in [Figure 27](#).

For the Fast commands, the x2 mode is not available.

Figure 27. Start of frame, high data rate, two subcarriers

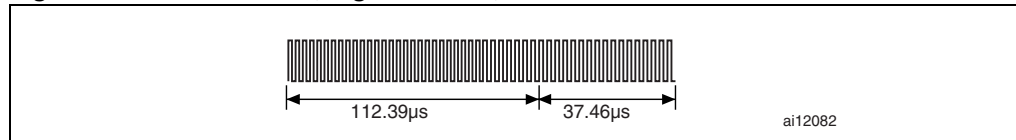

8.6 Low data rate

The SOF comprises 108 pulses at 484.28 kHz ($f_C/28$), followed by 96 pulses at 423.75 kHz ($f_C/32$), and a logic 1 that includes 36 pulses at 484.28 kHz followed by 32 pulses at 423.75 kHz as shown in [Figure 28](#).

For the Fast commands, the x2 mode is not available.

Figure 28. Start of frame, low data rate, two subcarriers

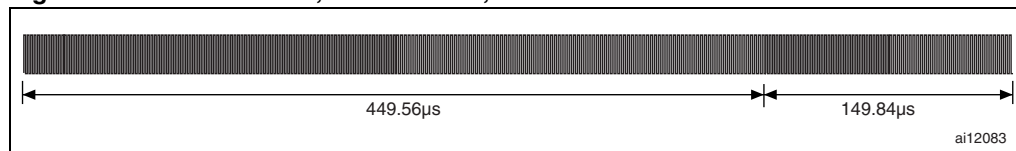

8.7 EOF when using one subcarrier

8.8 High data rate

The EOF comprises a logic 0 that includes 8 pulses at 423.75 kHz and an unmodulated time of 18.88 μs , followed by 24 pulses at 423.75 kHz ($f_C/32$), and by an unmodulated time of 56.64 μs as shown in [Figure 29](#).

Figure 29. End of frame, high data rate, one subcarriers

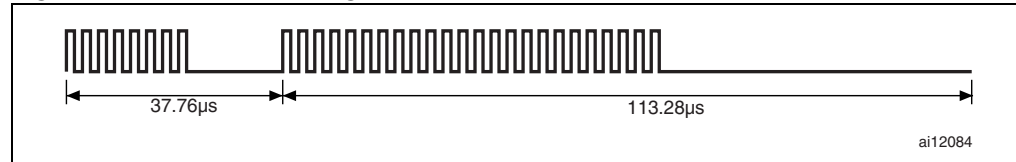

For the Fast commands, the EOF comprises a logic 0 that includes 4 pulses at 423.75 kHz and an unmodulated time of 9.44 μs , followed by 12 pulses at 423.75 kHz ($f_C/32$) and an unmodulated time of 37.76 μs as shown in [Figure 30](#).

Figure 30. End of frame, high data rate, one subcarriers x2

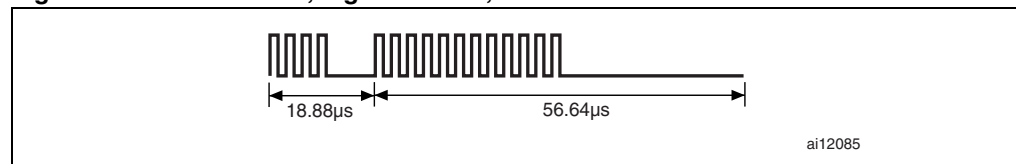

8.9 Low data rate

The EOF comprises a logic 0 that includes 32 pulses at 423.75 kHz and an unmodulated time of 75.52 μs , followed by 96 pulses at 423.75 kHz ($f_C/32$) and an unmodulated time of 226.56 μs as shown in [Figure 31](#).

Figure 31. End of frame, low data rate, one subcarriers

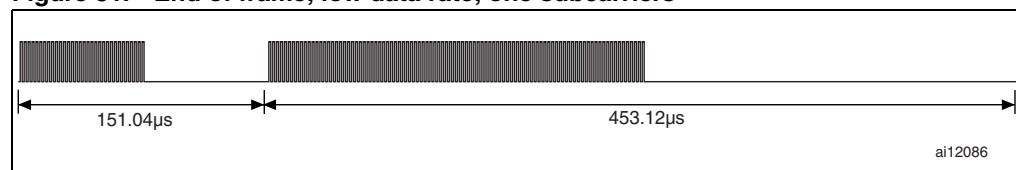

For the Fast commands, the EOF comprises a logic 0 that includes 16 pulses at 423.75 kHz and an unmodulated time of 37.76 μs , followed by 48 pulses at 423.75 kHz ($f_C/32$) and an unmodulated time of 113.28 μs as shown in [Figure 32](#).

Figure 32. End of frame, low data rate, one subcarriers x2

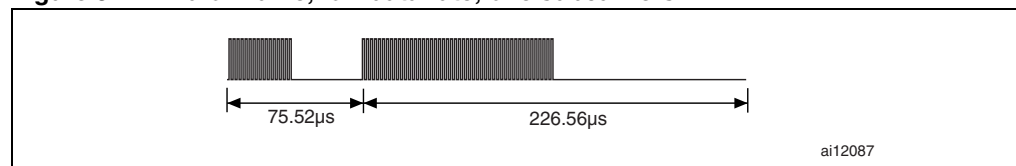

8.10 EOF when using two subcarriers

8.11 High data rate

The EOF comprises a logic 0 that includes 8 pulses at 423.75 kHz and 9 pulses at 484.28 kHz, followed by 24 pulses at 423.75 kHz ($f_D/32$) and 27 pulses at 484.28 kHz ($f_D/28$) as shown in [Figure 33](#).

For the Fast commands, the x2 mode is not available.

Figure 33. End of frame, high data rate, two subcarriers

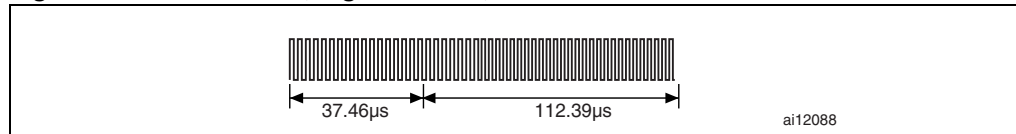

8.12 Low data rate

The EOF comprises a logic 0 that includes 32 pulses at 423.75 kHz and 36 pulses at 484.28 kHz, followed by 96 pulses at 423.75 kHz ($f_D/32$) and 108 pulses at 484.28 kHz ($f_D/28$) as shown in [Figure 34](#).

For the Fast commands, the x2 mode is not available.

Figure 34. End of frame, low data rate, two subcarriers

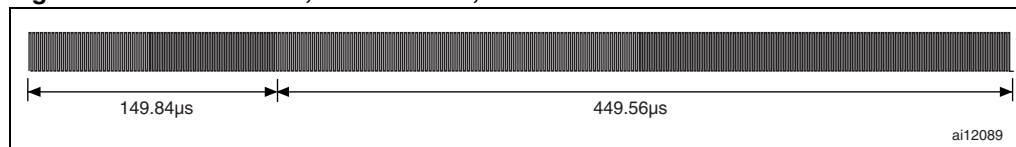

9 Unique identifier (UID)

The LRIS2Ks are uniquely identified by a 64-bit Unique Identifier (UID). This UID complies with ISO/IEC 15963 and ISO/IEC 7816-6. The UID is a read-only code and comprises:

- 8 MSBs with a value of E0h
- The IC Manufacturer code of ST 02h, on 8 bits (ISO/IEC 7816-6/AM1)
- a Unique Serial Number on 48 bits

Table 11. UID format

MSB		LSB			
63	56	55	48	47	0
0xE0		0x02		Unique serial number	

With the UID each LRIS2K can be addressed uniquely and individually during the anticollision loop and for one-to-one exchanges between a VCD and an LRIS2K.

10 Application family identifier (AFI)

The AFI (application family identifier) represents the type of application targeted by the VCD and is used to identify, among all the LRIS2Ks present, only the LRIS2Ks that meet the required application criteria.

Figure 35. LRIS2K decision tree for AFI

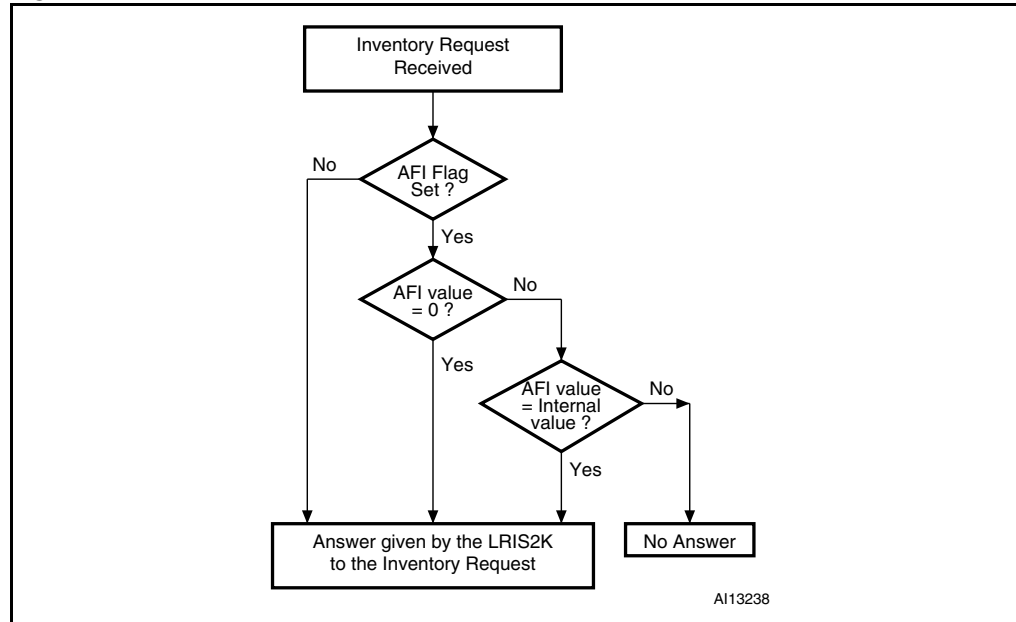

The AFI is programmed by the LRIS2K issuer (or purchaser) in the AFI register. Once programmed and Locked, it can no longer be modified.

The most significant nibble of the AFI is used to code one specific or all application families.

The least significant nibble of the AFI is used to code one specific or all application subfamilies. Subfamily codes different from 0 are proprietary.

(See ISO 15693-3 documentation)

11 Data storage format identifier (DSFID)

The data storage format identifier indicates how the data is structured in the LRIS2K memory. The logical organization of data can be known instantly using the DSFID.

It can be programmed and locked using the Write DSFID and Lock DSFID commands.

11.1 CRC

The CRC used in the LRIS2K is calculated as per the definition in ISO/IEC 13239.

The initial register contents are all ones: FFFFh.

The two-byte CRC are appended to each request and response, within each frame, before the EOF. The CRC is calculated on all the bytes after the SOF up to the CRC field.

Upon reception of a request from the VCD, the LRIS2K verifies that the CRC value is valid. If it is invalid, the LRIS2K discards the frame and does not answer to the VCD.

Upon reception of a request from the LRIS2K, it is recommended that the VCD verifies whether the CRC value is valid. If it is invalid, actions to be performed are left to the discretion of the VCD designer.

The CRC is transmitted least significant byte first.

Each byte is transmitted least significant bit first.

Table 12. CRC transmission rules

LSByte		MSByte	
LSBit	MSBit	LSBit	MSBit
CRC 16 (8 bits)		CRC 16 (8 bits)	

12 LRIS2K protocol description

The Transmission protocol (or simply protocol) defines the mechanism used to exchange instructions and data between the VCD and the LRIS2K, in both directions. It is based on the concept of “VCD talks first”.

This means that an LRIS2K will not start transmitting unless it has received and properly decoded an instruction sent by the VCD. The protocol is based on an exchange of:

- a request from the VCD to the LRIS2K
- a response from the LRIS2K to the VCD

Each request and each response are contained in a frame. The frame delimiters (SOF, EOF) are described in [Section 8: LRIS2K to VCD frames](#).

Each request consists of:

- a request SOF (see [Figure 8](#) and [Figure 9](#))
- flags
- a command code
- parameters, depending on the command
- application data
- a 2-byte CRC
- a request EOF (see [Figure 10](#))

Each response consists of:

- an Answer SOF (see [Figure 23](#) to [Figure 28](#))
- flags
- parameters, depending on the command
- application data
- a 2-byte CRC
- an Answer EOF (see [Figure 29](#) to [Figure 34](#))

The protocol is bit-oriented. The number of bits transmitted in a frame is a multiple of eight (8), i.e. an integer number of bytes.

A single-byte field is transmitted least significant bit (LSBit) first. A multiple-byte field is transmitted least significant byte (LSByte) first, each byte is transmitted least significant bit (LSBit) first.

The setting of the flags indicates the presence of the optional fields. When the flag is set (to one), the field is present. When the flag is reset (to zero), the field is absent.

Table 13. VCD request frame format

Request SOF	Request_flags	Command code	Parameters	Data	2-byte CRC	Request EOF
-------------	---------------	--------------	------------	------	------------	-------------

Table 14. LRIS2K response frame format

Response SOF	Response_flags	Parameters	Data	2-byte CRC	Response EOF
--------------	----------------	------------	------	------------	--------------

Figure 36. LRIS2K protocol timing

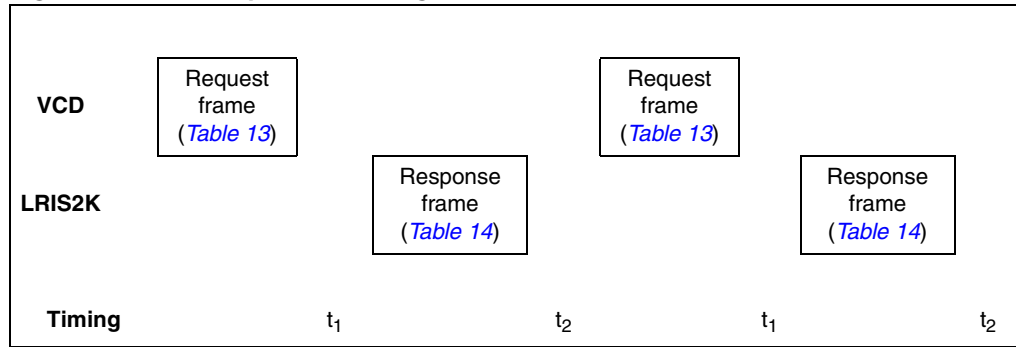

13 LRIS2K states

An LRIS2K can be in one of 4 states:

- Power-off
- Ready
- Quiet
- Selected

Transitions between these states are specified in [Figure 37: LRIS2K state transition diagram](#) and [Table 15: LRIS2K response depending on Request_flags](#).

13.1 Power-off state

The LRIS2K is in the Power-off state when it does not receive enough energy from the VCD.

13.2 Ready state

The LRIS2K is in the Ready state when it receives enough energy from the VCD. When in the Ready state, the LRIS2K answers any request where the Select_flag is not set.

13.3 Quiet state

When in the Quiet state, the LRIS2K answers any request except for Inventory requests with the Address_flag set.

13.4 Selected state

In the Selected state, the LRIS2K answers any request in all modes (see [Section 14: Modes](#)):

- request in Select mode with the Select_flag set
- request in Addressed mode if the UID matches
- request in Non-Addressed mode as it is the mode for general requests

Table 15. LRIS2K response depending on Request_flags

Flags	Address_flag		Select_flag	
	1 Addressed	0 Non addressed	1 Selected	0 Non selected
LRIS2K in Ready or Selected state (Devices in Quiet state do not answer)		X		X
LRIS2K in Selected state		X	X	
LRIS2K in Ready, Quiet or Selected state (the device which matches the UID)	X			X
Error (03h)	X		X	

Figure 37. LRIS2K state transition diagram

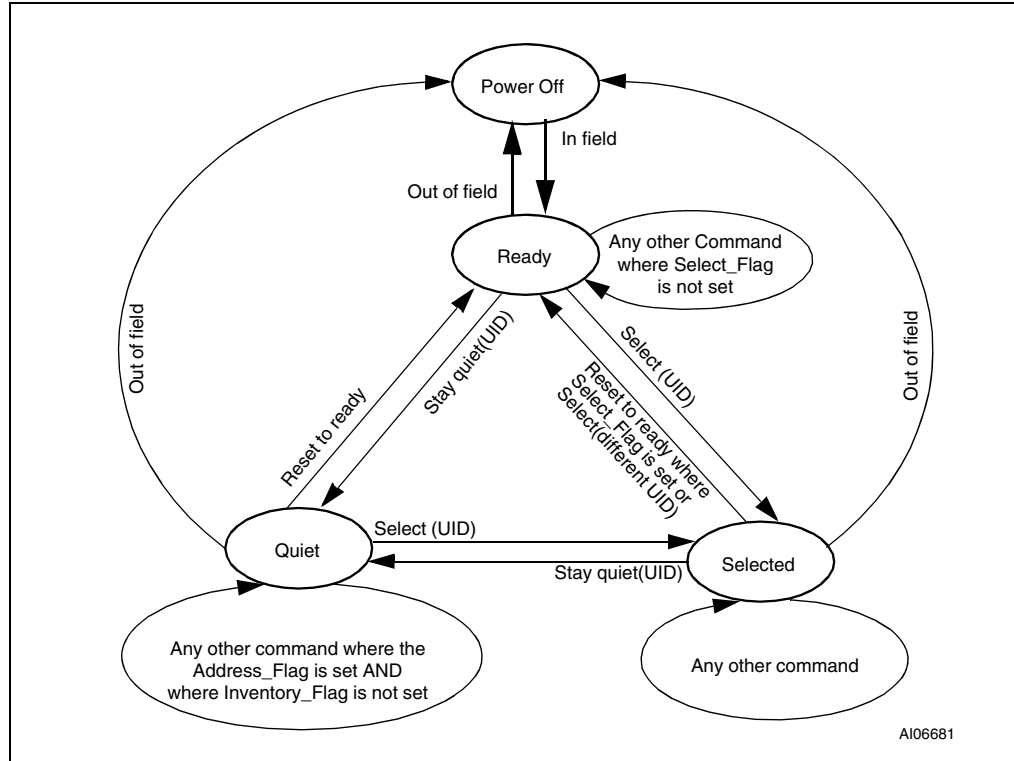

1. The intention of the state transition method is that only one LRIS2K should be in the selected state at a time.

14 Modes

The term “mode” refers to the mechanism used in a request to specify the set of LRIS2Ks that will answer the request.

14.1 Addressed mode

When the `Address_flag` is set to 1 (Addressed mode), the request contains the Unique ID (UID) of the addressed LRIS2K.

Any LRIS2K that receives a request with the `Address_flag` set to 1 compares the received Unique ID to its own. If it matches, then the LRIS2K executes the request (if possible) and returns a request to the VCD as specified in the command description.

If the UID does not match, then it remains silent.

14.2 Non-addressed mode (general request)

When the `Address_flag` is cleared to 0 (Non-Addressed mode), the request does not contain a Unique ID. Any LRIS2K receiving a request with the `Address_flag` cleared to 0 executes it and returns a request to the VCD as specified in the command description.

14.3 Select mode

When the `Select_flag` is set to 1 (Select mode), the request does not contain an LRIS2K Unique ID. The LRIS2K in the Selected state that receives a request with the `Select_flag` set to 1 executes it and returns a request to the VCD as specified in the command description.

Only LRIS2Ks in the Selected state answer a request where the `Select_flag` set to 1.

The system design ensures in theory that only one LRIS2K can be in the Select state at a time.

15 Request format

The request consists of:

- an SOF
- flags
- a command code
- parameters and data
- a CRC
- an EOF

Table 16. General request format

S O F	Request_flags	Command code	Parameters	Data	CRC	E O F
-------------	---------------	--------------	------------	------	-----	-------------

15.1 Request_flags

In a request, the “flags” field specifies the actions to be performed by the LRIS2K and whether corresponding fields are present or not.

The flag field consists of eight bits.

The bit 3 (Inventory_flag) of the request_flag defines the contents of the 4 MSBs (bits 5 to 8).

When bit 3 is reset (0), bits 5 to 8 define the LRIS2K selection criteria.

When bit 3 is set (1), bits 5 to 8 define the LRIS2K Inventory parameters.

Table 17. Definition of request_flags 1 to 4

Bit No	Flag	Level	Description
Bit 1	Subcarrier_flag ⁽¹⁾	0	A single subcarrier frequency is used by the LRIS2K
		1	Two subcarrier are used by the LRIS2K
Bit 2	Data_rate_flag ⁽²⁾	0	Low data rate is used
		1	High data rate is used
Bit 3	Inventory_flag	0	The meaning of flags 5 to 8 is described in Table 18
		1	The meaning of flags 5 to 8 is described in Table 19
Bit 4	Protocol Extension_flag	0	No Protocol format extension

1. Subcarrier_flag refers to the LRIS2K-to-VCD communication.

2. Data_rate_flag refers to the LRIS2K-to-VCD communication

Table 18. Request_flags 5 to 8 when Bit 3 = 0

Bit No	Flag	Level	Description
Bit 5	Select_flag ⁽¹⁾	0	Request is executed by any LRIS2K according to the setting of Address_flag
		1	Request is executed only by the LRIS2K in Selected state
Bit 6	Address_flag ⁽¹⁾	0	Request is not addressed. UID field is not present. The request is executed by all LRIS2Ks.
		1	Request is addressed. UID field is present. The request is executed only by the LRIS2K whose UID matches the UID specified in the request.
Bit 7	Option_flag	0	
Bit 8	RFU	0	

1. If the Select_flag is set to 1, the Address_flag is set to 0 and the UID field is not present in the request.

Table 19. Request_flags 5 to 8 when Bit 3 = 1

Bit No	Flag	Level	Description
Bit 5	AFI_flag	0	AFI field is not present
		1	AFI field is present
Bit 6	Nb_slots_flag	0	16 slots
		1	1 slot
Bit 7	Option_flag	0	
Bit 8	RFU	0	

16 Response format

The request consists of:

- an SOF
- flags
- parameters and data
- a CRC
- an EOF

Table 20. General response format

S O F	Response_flags	Parameters	Data	CRC	E O F
-------------	----------------	------------	------	-----	-------------

16.1 Response_flags

In a request, the flags indicate how actions have been performed by the LRIS2K and whether corresponding fields are present or not. The request_flags consist of eight bits.

Table 21. Definitions of response_flags 1 to 8

Bit No	Flag	Level	Description
Bit 1	Error_flag	0	No error
		1	Error detected. Error code is in the "Error" field.
Bit 2	RFU	0	
Bit 3	RFU	0	
Bit 4	Extension_flag	0	No extension
Bit 5	RFU	0	
Bit 6	RFU	0	
Bit 7	RFU	0	
Bit 8	RFU	0	

16.2 Response error code

If the Error_flag is set by the LRIS2K in the request, the Error code field is present and provides information about the error that occurred.

Error codes not specified in [Table 22](#) are reserved for future use.

Table 22. Response error code definition

Error code	Meaning
03h	The option is not supported
0Fh	Error with no information given
10h	The specified block is not available
11h	The specified block is already locked and thus cannot be locked again
12h	The specified block is locked and its contents cannot be changed.
13h	The specified block was not successfully programmed
14h	The specified block was not successfully locked

17 Anticollision

The purpose of the anticollision sequence is to inventory the LRIS2Ks present in the VCD field using their unique ID (UID).

The VCD is the master of communications with one or several LRIS2Ks. It initiates LRIS2K communication by issuing the Inventory request.

The LRIS2K sends its request in the determined slot or does not respond.

17.1 Request parameters

When issuing the Inventory command, the VCD:

- sets the Nb_slots_flag as desired
- adds the mask length and the mask value after the command field
- The mask length is the number of significant bits of the mask value.
- The mask value is contained in an integer number of bytes. The mask length indicates the number of significant bits. LSB is transmitted first
- If the mask length is not a multiple of 8 (bits), as many 0-bits as required will be added to the mask value MSB so that the mask value is contained in an integer number of bytes
- The next field starts at the next byte boundary.

Table 23. Inventory request format

MSB							LSB
SOF	Request_flags	Command	Optional AFI	Mask length	Mask value	CRC	EOF
	8 bits	8 bits	8 bits	8 bits	0 to 8 bytes	16 bits	

In the example of the [Table 24](#) and [Figure 38](#), the mask length is 11 bits. Five 0-bits are added to the mask value MSB. The 11-bit Mask and the current slot number are compared to the UID.

Table 24. Example of the addition of 0-bits to an 11-bit mask value

(b ₁₅) MSB	LSB (b ₀)
0000 0	100 1100 1111
0-bits added	11-bit mask value

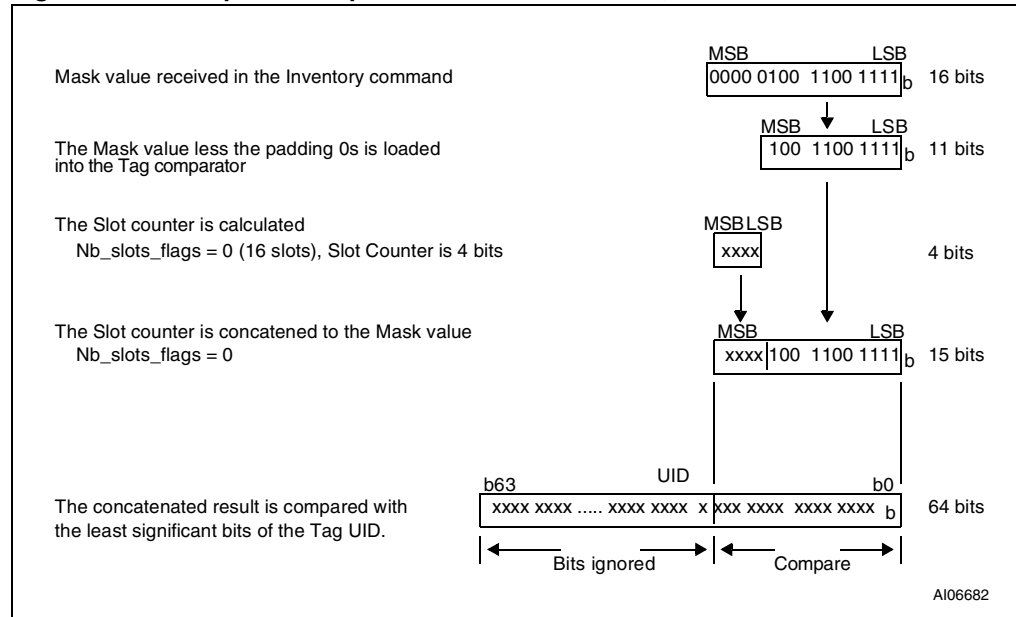
Figure 38. Principle of comparison between the mask, the slot number and the UID

The AFI field is present if the AFI_flag is set.

The pulse is generated according to the definition of the EOF in ISO/IEC 15693-2.

The first slot starts immediately after the reception of the request EOF. To switch to the next slot, the VCD sends an EOF.

The following rules and restrictions apply:

- if no LRIS2K answer is detected, the VCD may switch to the next slot by sending an EOF,
- if one or more LRIS2K answers are detected, the VCD waits until the complete frame has been received before sending an EOF for switching to the next slot.

18 Request processing by the LRIS2K

Upon reception of a valid request, the LRIS2K performs the following algorithm:

- NbS is the total number of slots (1 or 16)
- SN is the current slot number (0 to 15)
- LSB (value, n) function returns the n Less Significant Bits of value
- MSB (value, n) function returns the n Most Significant Bits of value
- “&” is the concatenation operator
- Slot_frame is either an SOF or an EOF

```
SN = 0
if (Nb_slots_flag)
  then NbS = 1
       SN_length = 0
       endif
  else NbS = 16
       SN_length = 4
       endif

label1:
if LSB(UID, SN_length + Mask_length) =
  LSB(SN, SN_length) & LSB(Mask, Mask_length)
  then answer to inventory request
  endif

wait (Slot_frame)

if Slot_frame = SOF
  then Stop Anticollision
       decode/process request
       exit
  endif

if Slot_frame = EOF
  if SN < NbS-1
    then SN = SN + 1
         goto label1
         exit
    endif
  endif
```

19 Explanation of the possible cases

Figure 39 summarizes the main possible cases that can occur during an anticollision sequence when the slot number is 16.

The different steps are:

- The VCD sends an Inventory request, in a frame terminated by an EOF. The number of slots is 16.
- LRIS2K 1 transmits its request in Slot 0. It is the only one to do so, therefore no collision occurs and its UID is received and registered by the VCD;
- The VCD sends an EOF in order to switch to the next slot.
- In slot 1, two LRIS2Ks, LRIS2K 2 and LRIS2K 3 transmit a request, thus generating a collision. The VCD records the event and remembers that a collision was detected in Slot 1.
- The VCD sends an EOF in order to switch to the next slot.
- In Slot 2, no LRIS2K transmits a request. Therefore the VCD does not detect any LRIS2K SOF and decides to switch to the next slot by sending an EOF.
- In slot 3, there is another collision caused by requests from LRIS2K 4 and LRIS2K 5
- The VCD then decides to send a request (for instance a Read Block) to LRIS2K 1 whose UID has already been correctly received.
- All LRIS2Ks detect an SOF and exit the anticollision sequence. They process this request and since the request is addressed to LRIS2K 1, only LRIS2K 1 transmits a request.
- All LRIS2Ks are ready to receive another request. If it is an Inventory command, the slot numbering sequence restarts from 0.

Note: *The decision to interrupt the anticollision sequence is made by the VCD. It could have continued to send EOFs until Slot 16 and only then sent the request to LRIS2K 1.*

Figure 39. Description of a possible anticollision sequence

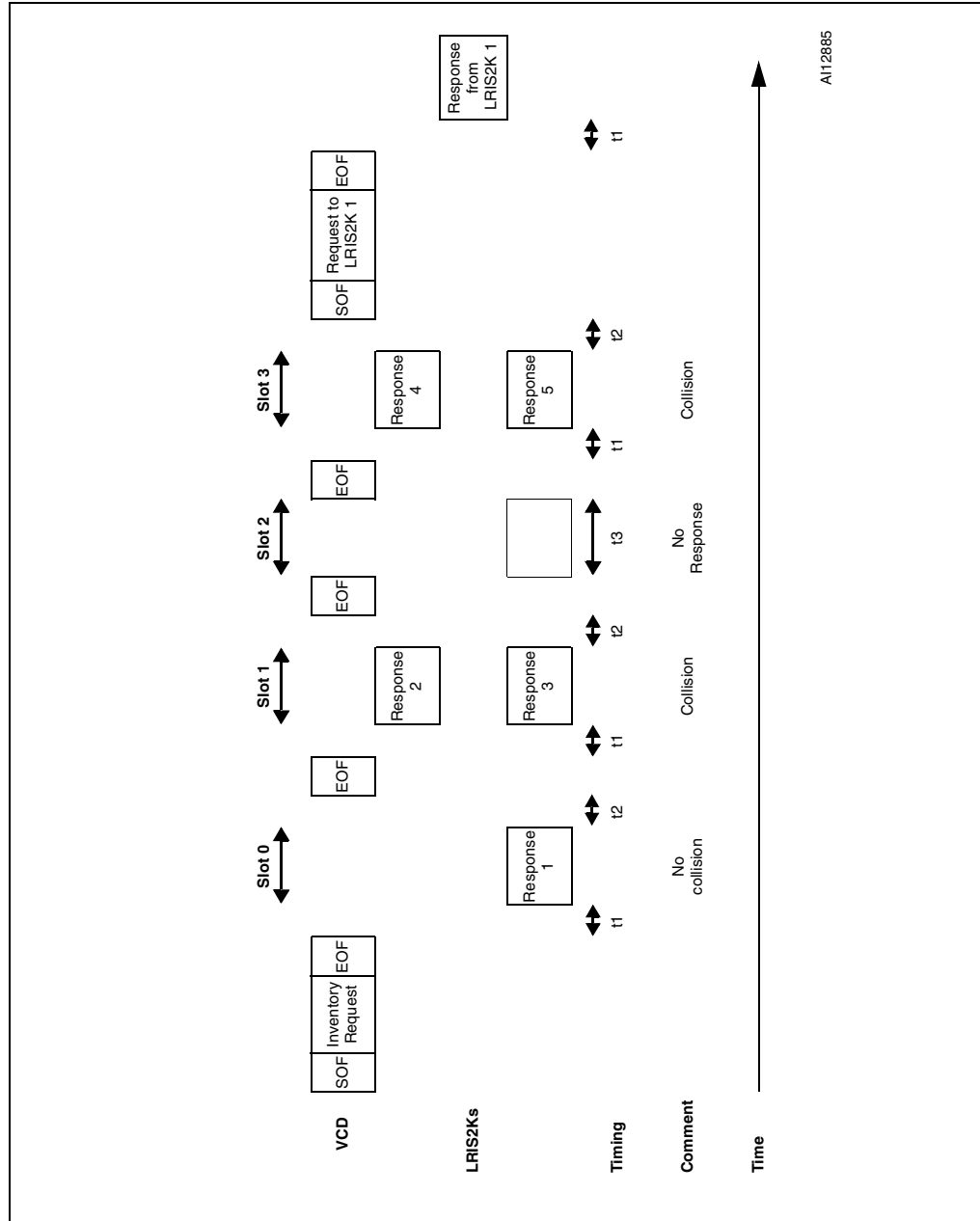

20 Inventory Initiated command

The LRIS2K provides a special feature to improve the inventory time response of moving tags using the `Initiate_flag` value. This flag, controlled by the `Initiate` command, allows tags to answer to `Inventory Initiated` commands.

For applications in which multiple tags are moving in front of a reader, it is possible to miss tags using the standard inventory command. The reason is that the inventory sequence has to be performed on a global tree search. For example, a tag with a particular UID value may have to wait the run of a long tree search before being inventoried. If the delay is too long, the tag may be out of the field before it has been detected.

Using the `Initiate` command, the inventory sequence is optimized. When multiple tags are moving in front of a reader, the ones which are within the reader field will be initiated by the `Initiate` command. In this case, a small batch of tags will answer to the `Inventory Initiated` command which will optimize the time necessary to identify all the tags. When finished, the reader has to issue a new `Initiate` command in order to initiate a new small batch of tags which are new inside the reader field.

It is also possible to reduce the inventory sequence time using the `Fast Initiate` and `Fast Inventory Initiated` commands. These commands allow the LRIS2Ks to increase their response data rate by a factor of 2, up to 53kbit/s.

21 Timing definition

21.1 t_1 : LRIS2K response delay

Upon detection of the rising edge of the EOF received from the VCD, the LRIS2K waits for a time t_{1nom} before transmitting its response to a VCD request or before switching to the next slot during an inventory process. Values of t_1 are given in [Table 25](#). The EOF is defined in [Figure 10 on page 24](#).

21.2 t_2 : VCD new request delay

t_2 is the time after which the VCD may send an EOF to switch to the next slot when one or more LRIS2K responses have been received during an Inventory command. It starts from the reception of the EOF from the LRIS2Ks.

The EOF sent by the VCD may be either 10% or 100% modulated regardless of the modulation index used for transmitting the VCD request to the LRIS2K.

t_2 is also the time after which the VCD may send a new request to the LRIS2K as described in [Figure 36: LRIS2K protocol timing](#).

Values of t_2 are given in [Table 25](#).

21.3 t_3 : VCD new request delay in the absence of a response from the LRIS2K

t_3 is the time after which the VCD may send an EOF to switch to the next slot when no LRIS2K response has been received.

The EOF sent by the VCD may be either 10% or 100% modulated regardless of the modulation index used for transmitting the VCD request to the LRIS2K.

From the time the VCD has generated the rising edge of an EOF:

- If this EOF is 100% modulated, the VCD waits a time at least equal to t_{3min} before sending a new EOF.
- If this EOF is 10% modulated, the VCD waits a time at least equal to the sum of t_{3min} + the LRIS2K nominal response time (which depends on the LRIS2K data rate and subcarrier modulation mode) before sending a new EOF.

Table 25. Timing values⁽¹⁾

	Minimum (min) values	Nominal (nom) values	Maximum (max) values
t_1	318.6 μ s	320.9 μ s	323.3 μ s
t_2	309.2 μ s	No t_{nom}	No t_{max}
t_3	$t_{1max}^{(2)} + t_{SOF}^{(3)}$	No t_{nom}	No t_{max}

1. The tolerance of specific timings is $\pm 32/f_C$.

2. t_{1max} does not apply for write alike requests. Timing conditions for write alike requests are defined in the command description.

3. t_{SOF} is the time taken by the LRIS2K to transmit an SOF to the VCD. t_{SOF} depends on the current data rate: High data rate or Low data rate.

22 Commands codes

The LRIS2K supports the commands described in this section. Their codes are given in [Table 26](#).

Table 26. Command codes

Command code standard	Function	Command code custom	Function
01h	Inventory	A6h	Kill
02h	Stay Quiet	B1h	Write password
20h	Read Single Block	B2h	Lock Password
21h	Write Single Block	B3h	Present Password
22h	Lock Block	C0h	Fast Read Single Block
25h	Select	C1h	Fast Inventory Initiated
26h	Reset to Ready	C2h	Fast Initiate
27h	Write AFI	D1h	Inventory Initiated
28h	Lock AFI	D2h	Initiate
29h	Write DSFID		
2Ah	Lock DSFID		
2Bh	Get System Info		
2Ch	Get Multiple Block Security Status		

23 Inventory

When receiving the Inventory request, the LRIS2K runs the anticollision sequence. The Inventory_flag is set to 1. The meaning of flags 5 to 8 is shown in [Table 19: Request_flags 5 to 8 when Bit 3 = 1](#).

The request contains the:

- flags
- Inventory command code (see [Table 26: Command codes](#))
- AFI if the AFI flag is set
- mask length
- mask value
- CRC

The LRIS2K does not generate any answer in case of error.

Table 27. Inventory request format

Request SOF	Request_flags	Inventory	Optional AFI	Mask length	Mask value	CRC16	Request EOF
	8 bits	01h	8 bits	8 bits	0 - 64 bits	16 bits	

The response contains the:

- flags
- unique ID

Table 28. Inventory response format

Response SOF	Response_flags	DSFID	UID	CRC16	Response EOF
	8 bits	8 bits	64 bits	16 bits	

During an Inventory process, if the VCD does not receive an RF LRIS2K response, it waits a time t_3 before sending an EOF to switch to the next slot. t_3 starts from the rising edge of the request EOF sent by the VCD.

- If the VCD sends a 100% modulated EOF, the minimum value of t_3 is:
 $t_{3min} = 4384/f_C (323.3\mu s) + t_{SOF}$
- If the VCD sends a 10% modulated EOF, the minimum value of t_3 is:
 $t_{3min} = 4384/f_C (323.3\mu s) + t_{NRT}$

where:

- t_{SOF} is the time required by the LRIS2K to transmit an SOF to the VCD
- t_{NRT} is the nominal response time of the LRIS2K

t_{NRT} and t_{SOF} are dependent on the LRIS2K-to-VCD data rate and subcarrier modulation mode.

24 Stay Quiet

Command code = 0x02

On receiving the Stay Quiet command, the LRIS2K enters the Quiet state and does NOT send back a request. There is NO response to the Stay Quiet command even if an error occurs.

When in the Quiet state:

- the LRIS2K does not process any request if the Inventory_flag is set,
- the LRIS2K processes any Addressed request

The LRIS2K exits the Quiet state when:

- it is reset (power off),
- receiving a Select request. It then goes to the Selected state,
- receiving a Reset to Ready request. It then goes to the Ready state.

Table 29. Stay Quiet request format

Request SOF	Request_flags	Stay Quiet	UID	CRC16	Request EOF
	8 bits	02h	64 bits	16 bits	

The Stay Quiet command must always be executed in Addressed mode (Select_flag is reset to 0 and Address_flag is set to 1).

Figure 40. Stay Quiet frame exchange between VCD and LRIS2K

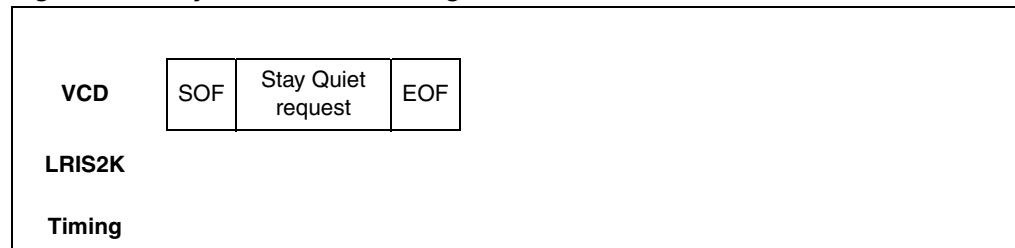

25 Read Single Block

On receiving the Read Single Block command, the LRIS2K reads the requested block and sends back its 32 bits value in the request. The Option_flag is supported and gives access to the protect status.

Table 30. Read Single Block request format

Request SOF	Request_flags	Read Single Block	UID	Block number	CRC16	Request EOF
	8 bits	20h	64 bits	8 bits	16 bits	

Request parameters:

- Option_flag
- UID (optional)
- Block number

Table 31. Read Single Block response format when Error_flag is NOT set

Response SOF	Response_flags	Block locking status	Data	CRC16	Response EOF
	8 bits	8 bits	32 bits	16 bits	

Response parameters:

- Block Locking Status if Option_flag is set (see [Table 32: Block Locking status](#))
- 4 bytes of block data

Table 32. Block Locking status

b ₇	b ₆	b ₅	b ₄	b ₃	b ₂	b ₁	b ₀
Reserved for future use. All at 0			password control bits		Read / Write protection bits		0: Current Block not locked 1: Current Block locked

Table 33. Read Single Block response format when Error_flag is set

Response SOF	Response Flags	Error code	CRC16	Response EOF
	8 bits	8 bits	16 bits	

Response parameter:

- Error code as Error_flag is set
 - 0Fh: other error
 - 10h: block address not available

Figure 41. Read Single Block frame exchange between VCD and LRIS2K

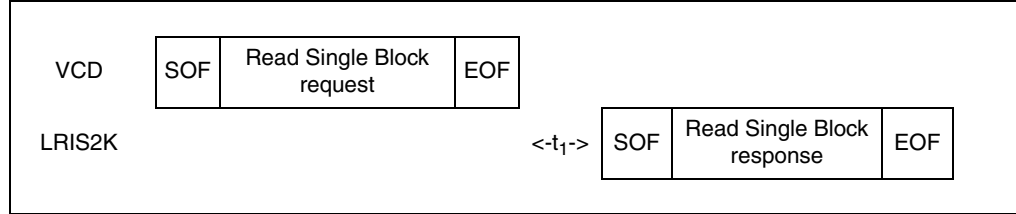

26 Write Single Block

On receiving the Write Single Block command, the LRIS2K writes the data contained in the request to the requested block and reports whether the write operation was successful in the request. The Option_flag is supported.

During the write cycle t_{W} , there should be no modulation (neither 100% nor 10%). Otherwise, the LRIS2K may not program correctly the data into the memory. The t_{W} time is equal to $t_{1nom} + 18 \times 302 \mu s$.

Table 34. Write Single Block request format

Request SOF	Request_flags	Write Single Block	UID	Block number	Data	CRC16	Request EOF
	8 bits	21h	64 bits	8 bits	32 bits	16 bits	

Request parameters:

- UID (optional)
- Block number
- Data

Table 35. Write Single Block response format when Error_flag is NOT set

Response SOF	Response_flags	CRC16	Response EOF
	8 bits	16 bits	

Response parameter:

- No parameter. The response is send back after the writing cycle.

Table 36. Write Single Block response format when Error_flag is set

Response SOF	Response_Flags	Error code	CRC16	Response EOF
	8 bits	8 bits	16 bits	

Response parameter:

- Error code as Error_flag is set:
 - 10h: block address not available
 - 12h: block is locked
 - 13h: block not programmed

Figure 42. Write Single Block frame exchange between VCD and LRIS2K

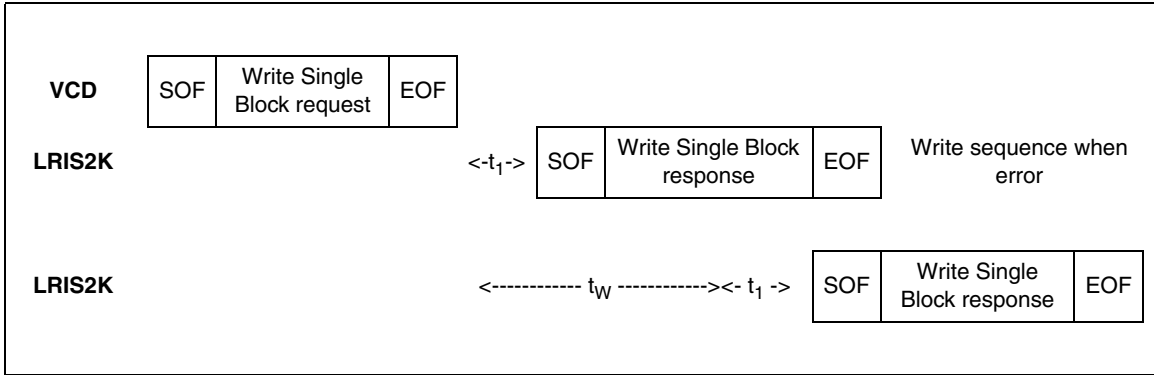

27 Lock Block

On receiving the Lock Block command, the LRIS2K permanently locks the selected block.

During the write cycle t_{W} , there should be no modulation (neither 100% nor 10%).

Otherwise, the LRIS2K may not lock correctly the memory block. The t_{W} time is equal to $t_{1nom} + 18 \times 302\mu s$.

Table 37. Lock Single Block request format

Request SOF	Request flags	Lock Block	UID	Block number	CRC16	Request EOF
	8 bits	22h	64 bits	8 bits	16 bits	

Request parameters:

- (Optional) UID
- Block number

Table 38. Lock Block response format when Error_flag is NOT set

Response SOF	Response flags	CRC16	Response EOF
	8 bits	16 bits	

Response parameter:

- No parameter.

Table 39. Lock Block response format when Error_flag is set

Response SOF	Response Flags	Error code	CRC16	Response EOF
	8 bits	8 bits	16 bits	

Response parameter:

- Error code as Error_flag is set:
 - 10h: block address not available
 - 11h: block is locked
 - 14h: block not locked

Figure 43. Lock Block frame exchange between VCD and LRIS2K

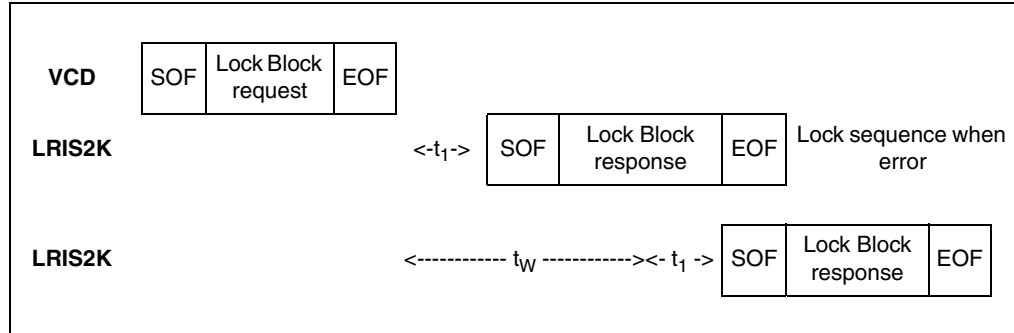

28 Select

When receiving the Select command:

- if the UID is equal to its own UID, the LRIS2K enters or stays in the Selected state and sends a request.
- if the UID does not match its own, the selected LRIS2K returns to the Ready state and does not send a request.

The LRIS2K answers an error code only if the UID is equal to its own UID. If not, no response is generated.

Table 40. Select request format

Request SOF	Request_flags	Select	UID	CRC16	Request EOF
	8 bits	25h	64 bits	16 bits	

Request parameter:

- UID

Table 41. Select Block response format when Error_flag is NOT set

Response SOF	Response_flags	CRC16	Response EOF
	8 bits	16 bits	

Response parameter:

- No parameter.

Table 42. Select response format when Error_flag is set

Response SOF	Response_Flags	Error code	CRC16	Response EOF
	8 bits	8 bits	16 bits	

Response parameter:

- Error code as Error_flag is set:
 - 0Fh: other error

Figure 44. Select frame exchange between VCD and LRIS2K

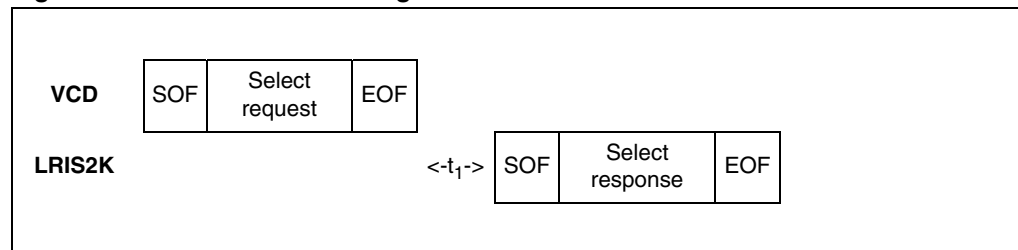

29 Reset to Ready

On receiving a Reset to Ready command, the LRIS2K returns to the Ready state. In the Addressed mode, the LRIS2K answers an error code only if the UID is equal to its own UID. If not, no response is generated.

Table 43. Reset to Ready request format

Request SOF	Request flags	Reset to Ready	UID	CRC16	Request EOF
	8 bits	26h	64 bits	16 bits	

Request parameter:

- UID (Optional)

Table 44. Reset to Ready response format when Error_flag is NOT set

Response SOF	Response flags	CRC16	Response EOF
	8 bits	16 bits	

Response parameter:

- No parameter

Table 45. Reset to Ready request format when Error_flag is set

Response SOF	Response flags	Error code	CRC16	Response EOF
	8 bits	8 bits	16 bits	

Response parameter:

- Error code as Error_flag is set:
 - 0Fh: other error

Figure 45. Reset to Ready frame exchange between VCD and LRIS2K

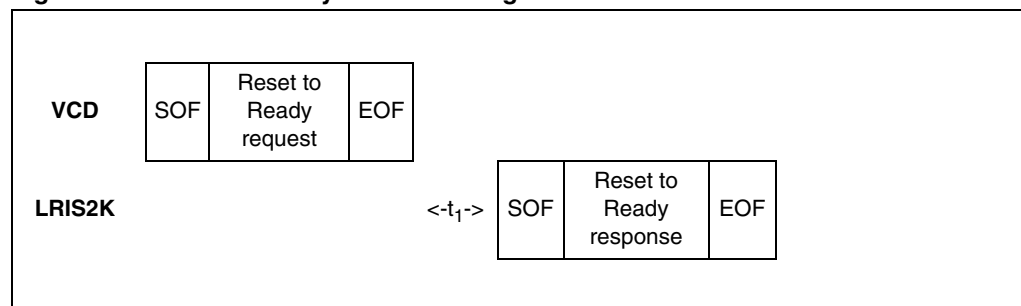

30 Write AFI

On receiving the Write AFI request, the LRIS2K writes the AFI byte value into its memory.

During the write cycle t_{W} , there should be no modulation (neither 100% nor 10%). Otherwise, the LRIS2K may not write correctly the AFI value into the memory. The t_{W} time is equal to $t_{1nom} + 18 \times 302 \mu s$.

Table 46. Write AFI request format

Request SOF	Request _flags	Write AFI	UID	AFI	CRC16	Request EOF
	8 bits	27h	64 bits	8 bits	16 bits	

Request parameters:

- UID (Optional)
- AFI

Table 47. Write AFI response format when Error_flag is NOT set

Response SOF	Response_flags	CRC16	Response EOF
	8 bits	16 bits	

Response parameter:

- No parameter.

Table 48. Write AFI response format when Error_flag is set

Response SOF	Response_Flags	Error code	CRC16	Response EOF
	8 bits	8 bits	16 bits	

Response parameter:

- Error code as Error_flag is set
 - 12h: block is locked
 - 13h: block not programmed

Figure 46. Write AFI frame exchange between VCD and LRIS2K

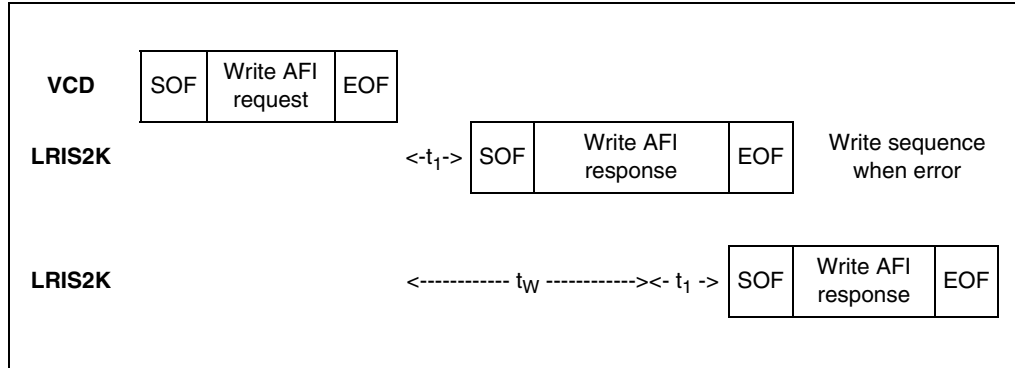

31 Lock AFI

On receiving the Lock AFI request, the LRIS2K locks the AFI value permanently.

During the write cycle t_W , there should be no modulation (neither 100% nor 10%). Otherwise, the LRIS2K may not Lock correctly the AFI value in memory. The t_W time is equal to $t_{1nom} + 18 \times 302 \mu s$.

Table 49. Lock AFI request format

Request SOF	Request_ flags	Lock AFI	UID	CRC16	Request EOF
	8 bits	28h	64 bits	16 bits	

Request parameter:

- UID (optional)

Table 50. Lock AFI response format when Error_flag is NOT set

Response SOF	Response_ flags	CRC16	Response EOF
	8 bits	16 bits	

Response parameter:

- No parameter

Table 51. Lock AFI response format when Error_flag is set

Response SOF	Response_ Flags	Error code	CRC16	Response EOF
	8 bits	8 bits	16 bits	

Response parameter:

- Error code as Error_flag is set
 - 11h: block is locked
 - 14h: block not locked

Figure 47. Lock AFI frame exchange between VCD and LRIS2K

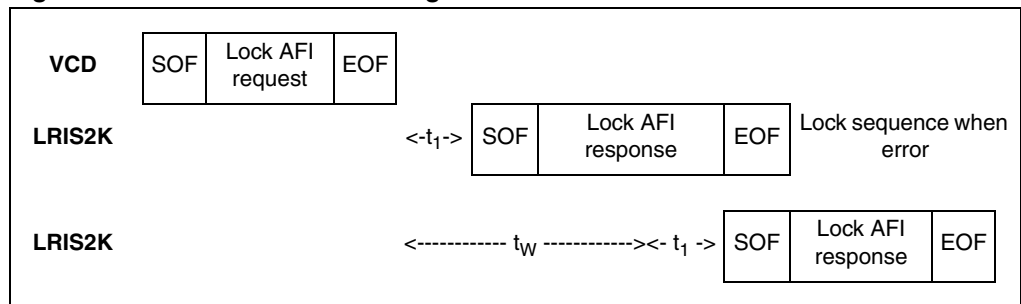

32 Write DSFID

On receiving the Write DSFID request, the LRIS2K writes the DSFID byte value into its memory.

During the write cycle t_W , there should be no modulation (neither 100% nor 10%). Otherwise, the LRIS2K may not write correctly the DSFID value in memory. The t_W time is equal to $t_{1nom} + 18 \times 302 \mu s$.

Table 52. Write DSFID request format

Request SOF	Request_flags	Write DSFID	UID	DSFID	CRC16	Request EOF
	8 bits	29h	64 bits	8 bits	16 bits	

Request parameters:

- UID (optional)
- DSFID

Table 53. Write DSFID response format when Error_flag is NOT set

Response SOF	Response_flags	CRC16	Response EOF
	8 bits	16 bits	

Response parameter:

- No parameter

Table 54. Write DSFID response format when Error_flag is set

Response SOF	Response_flags	Error code	CRC16	Response EOF
	8 bits	8 bits	16 bits	

Response parameter:

- Error code as Error_flag is set
 - 12h: block is locked
 - 13h: block not programmed

Figure 48. Write DSFID frame exchange between VCD and LRIS2K

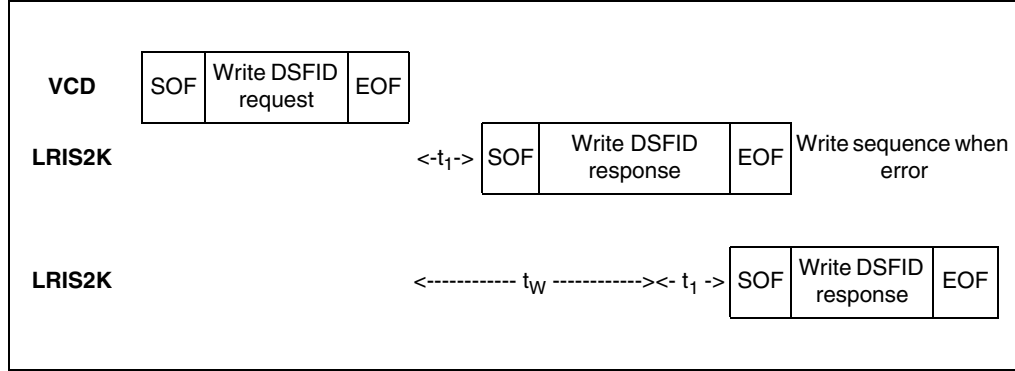

33 Lock DSFID

On receiving the Lock DSFID request, the LRIS2K locks the DSFID value permanently.

During the write cycle t_W , there should be no modulation (neither 100% nor 10%). Otherwise, the LRIS2K may not lock correctly the DSFID value in memory. The t_W time is equal to $t_{1nom} + 18 \times 302 \mu s$.

Table 55. Lock DSFID request format

Request SOF	Request flags	Lock DSFID	UID	CRC16	Request EOF
	8 bits	2Ah	64 bits	16 bits	

Request parameter:

- UID (optional)

Table 56. Lock DSFID response format when Error_flag is NOT set

Response SOF	Response flags	CRC16	Response EOF
	8 bits	16 bits	

Response parameter:

- No parameter.

Table 57. Lock DSFID response format when Error_flag is set

Response SOF	Response flags	Error code	CRC16	Response EOF
	8 bits	8 bits	16 bits	

Response parameter:

- Error code as Error_flag is set:
 - 11h: block is locked
 - 14h: block not locked

Figure 49. Lock DSFID frame exchange between VCD and LRIS2K

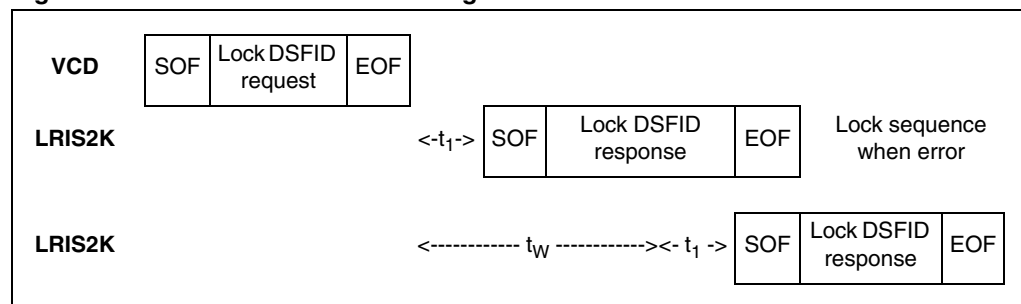

34 Get System Info

When receiving the Get System Info command, the LRIS2K sends back its information data in the request. The Option_flag is supported and must be reset to 0. The Get System Info can be issued in both Addressed and Non Addressed modes.

Table 58. Get System Info request format

Request SOF	Request_flags	Get System Info	UID	CRC16	Request EOF
	8 bits	2Bh	64 bits	16 bits	

Request parameter:

- UID (optional)

Table 59. Get System Info response format when Error_flag is NOT set

Response SOF	Response_flags	Information_flags	UID	DSFID	AFI	Memory Size	IC reference	CRC16	Response EOF
	00h	0Fh	64 bits	8 bits	8 bits	033Fh	001010xx _b	16 bits	

Response parameters:

- Information flags set to 0Fh. DSFID, AFI, memory size and IC reference fields are present
- UID code on 64 bits
- DSFID value
- AFI value
- Memory size. The LRIS2K provides 64 blocks (3Fh) of 4 byte (03h)
- IC Reference. Only the 6 MSB are significant. The product code of the LRIS2K is 00 1010_b=10_d

Table 60. Get System Info response format when Error_flag is set

Response SOF	Response_flags	Error code	CRC16	Response EOF
	01h	0Fh	16 bits	

Response parameter:

- Error code as Error_flag is set:
 - 03h: Option not supported
 - 0Fh: other error

Figure 50. Get System Info frame exchange between VCD and LRIS2K

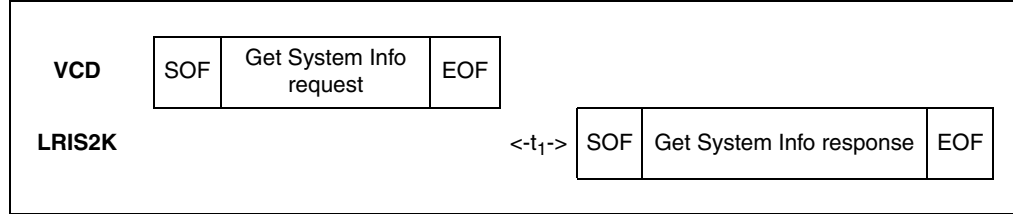

35 Get Multiple Block Security Status

When receiving the Get Multiple Block Security Status command, the LRIS2K sends back the block security status. The blocks are numbered from '00' to '3F' in the request and the value is minus one (-1) in the field. For example, a value of '06' in the "Number of blocks" field requests to return the security status of 7 blocks. In request, option flag must be set to 0.

Table 61. Get Multiple Block Security Status request format

Request SOF	Request _flags	Get Multiple Block Security Status	UID	First block number	Number of blocks	CRC16	Request EOF
	8 bits	2Ch	64 bits	8 bits	8 bits	16 bits	

Request parameters:

- UID (optional)
- First block number
- Number of blocks

Table 62. Get Multiple Block Security Status response format when Error_flag is NOT set

Response SOF	Response_Flags	Block locking status	CRC16	Response EOF
	8 bits	8 bits ⁽¹⁾	16 bits	

1. Repeated as needed.

Response parameters:

- Block Locking Status (see [Table 63: Block Locking status](#))
- N blocks of data

Table 63. Block Locking status

b ₇	b ₆	b ₅	b ₄	b ₃	b ₂	b ₁	b ₀
Reserved for future use. All at 0			password control bits		Read / Write protection bits		0: Current Block not locked 1: Current Block locked

Table 64. Get Multiple Block Security Status response format when Error_flag is set

Response SOF	Response_Flags	Error code	CRC16	Response EOF
	8 bits	8 bits	16 bits	

Response parameter:

- Error code as Error_flag is set:
 - 03h: Option not supported
 - 0Fh: other error

Figure 51. Get Multiple Block Security Status frame exchange between VCD and LRIS2K

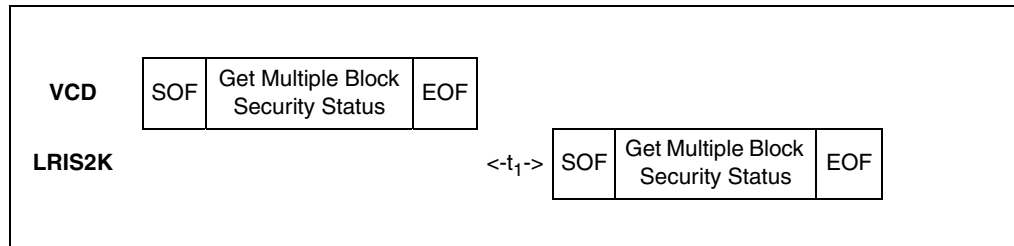

36 Kill

On receiving the Kill command, in the Addressed mode only, the LRIS2K compares the kill code with the data contained in the request and reports whether the operation was successful in the request. If the command is received in the Non Addressed or the Selected mode, the LRIS2K returns an error response.

During the comparison cycle equal to t_W , there should be no modulation (neither 100% nor 10%). Otherwise, the LRIS2K may not match the kill code correctly. The t_W time is equal to $t_{1nom} + 18 \times 302 \mu s$. After a successful Kill command, the LRIS2K is deactivated and does not interpret any other command.

Table 65. Kill request format

Request SOF	Request _flags	Kill	IC MFG Code	UID	Kill access	Kill code	CRC16	Request EOF
	8 bits	A6h	0x02	64 bits	00h	32 bits	16bits	

Request parameters:

- UID
- Kill code

Table 66. Kill response format when Error_flag is NOT set

Response SOF	Response_flags	CRC16	Response EOF
	8 bits	16 bits	

Response parameter:

- No parameter. The response is send back after the writing cycle

Table 67. Kill response format when Error_flag is set

Response SOF	Response_Flags	Error code	CRC16	Response EOF
	8 bits	8 bits	16 bits	

Response parameter:

- Error code as Error_flag is set:
 - 0Fh: other error
 - 14h: LRIS2K not killed

Figure 52. Kill frame exchange between VCD and LRIS2K

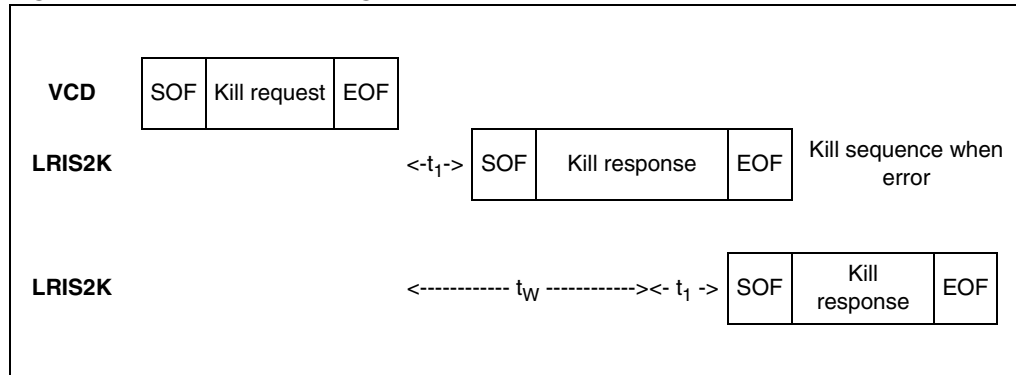

37 Write Password

On receiving the Write Password command, the LRIS2K uses the data contained in the request to write the password and reports whether the operation was successful in the request. The Option_flag is supported.

During the write cycle time, t_{W} , there must be no modulation at all (neither 100% nor 10%). Otherwise, the LRIS2K may not correctly program the data into the memory. The t_{W} time is equal to $t_{1nom} + 18 \times 302 \mu s$. After a successful write, the selected password must be locked again by issuing a Lock Password command to re-activate the block protection.

Prior to writing the password for a block, the Write Password command erases the Protect Status area of the block.

Table 68. Write Password request format

Request SOF	Request _flags	Write Password	IC MFG code	UID	Password number	Data	CRC16	Request EOF
	8 bits	B1h	02h	64 bits	8 bits	32 bits	16 bits	

Request parameters:

- UID (optional)
- Password number (00h = Kill, 01h = Pswd1, 02h = Pswd2, 03h = Pswd3, other = Error)
- Data

Table 69. Write Password response format when Error_flag is NOT set

Response SOF	Response_flags	CRC16	Response EOF
	8 bits	16 bits	

Response parameter:

- 32-bit password value. The response is sent back after the write cycle.

Table 70. Write Password response format when Error_flag is set

Response SOF	Response_Flags	Error code	CRC16	Response EOF
	8 bits	8 bits	16 bits	

Response parameter:

- Error code as Error_flag is set:
 - 10h: block address not available
 - 12h: block is locked
 - 13h: block not programmed

Figure 53. Write Password frame exchange between VCD and LRIS2K

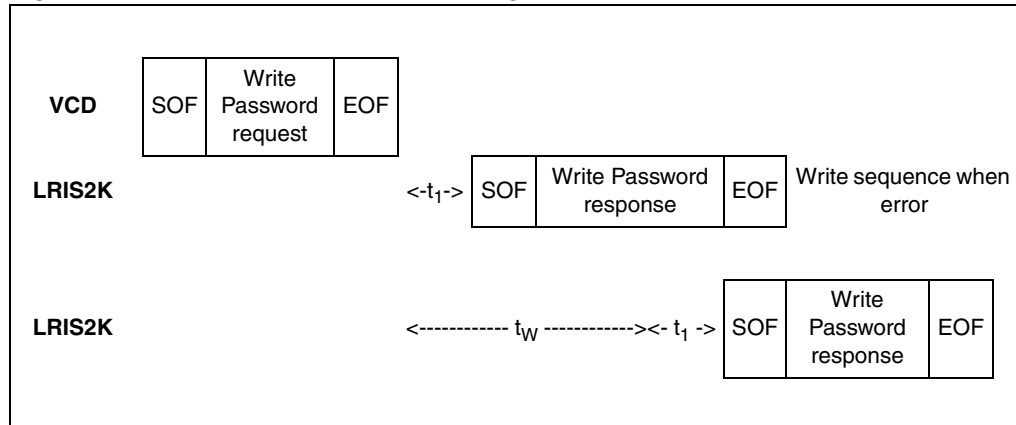

38 Lock Password

On receiving the Lock Password command, the LRIS2K sets the access rights and permanently locks the selected block. The Option_flag is supported. RFU bit 8 of the request_flag is used to select either the memory area (bit 8 = '0') or the password area (bit 8 = '1').

During the write cycle t_W , there should be no modulation (neither 100% nor 10%) otherwise, the LRIS2K may not correctly lock the memory block.

The t_W time is equal to $t_{1nom} + 18 \times 302 \mu s$.

Table 71. Lock Password request format

Request SOF	Request _flags	Lock Password	IC MFG code	UID	Block number	Protect Status	CRC16	Request EOF
	8 bits	B2h	02h	64 bits	8 bits	8 bits	16 bits	

Request parameters:

- (Optional) UID
- Block number (bit 8 = '1': 00h = Kill, 01h = Pswd1, 02h = Pswd2, 03h = Pswd3, other = Error)
- Protect status (refer to [Table 72](#))

Table 72. Protect status

b ₇	b ₆	b ₅	b ₄	b ₃	b ₂	b ₁	b ₀
0	0	0	password control bits		Read / Write protection bits ⁽¹⁾		1

1. b1b2 is 00 or 11. Other combinations are reserved but will behave as 11 in terms of protection settings.

Table 73. Lock Password response format when Error_flag is NOT set

Response SOF	Response_flags	CRC16	Response EOF
	8 bits	16 bits	

Response parameter:

- No parameter.

Table 74. Lock Password response format when Error_flag is set

Response SOF	Response_Flags	Error code	CRC16	Response EOF
	8 bits	8 bits	16 bits	

Response parameter:

- Error code as Error_flag is set:
 - 10h: block address not available
 - 11h: block is locked
 - 14: block not locked

Figure 54. Lock Password frame exchange between VCD and LRIS2K

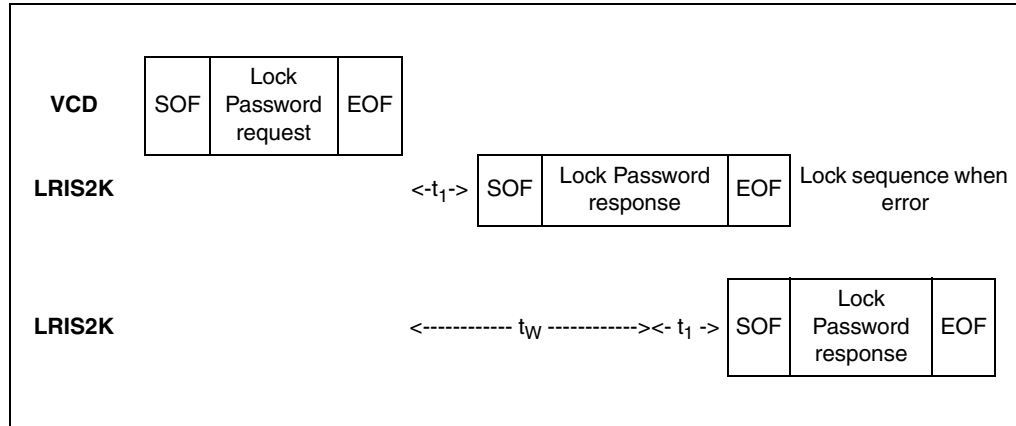

39 Present Password

On receiving the Present Password command, the LRIS2K compares the requested password with the data contained in the request and reports whether the operation has been successful in the request. The Option_flag is supported.

During the comparison cycle equal to t_{W} , there should be no modulation (neither 100% nor 10%) otherwise, the LRIS2K the Password value may not be correctly compared.

The t_{W} time is equal to $t_{1\text{nom}} + 18 \times 302 \mu\text{s}$.

After a successful command, the access to all the memory blocks linked to the password is changed as described in [Section 2: LRIS2K block security](#).

Table 75. Present Password request format

Request SOF	Request _flags	Present Password	IC MFG code	UID	Password number	Data	CRC16	Request EOF
	8 bits	B3h	02h	64 bits	8 bits	32 bits	16 bits	

Request parameters:

- UID (optional)
- Password number (0x01 = Pswd1, 0x02 = Pswd2, 0x03 = Pswd3, other = Error)
- Data

Table 76. Present Password response format when Error_flag is NOT set

Response SOF	Response_flags	CRC16	Response EOF
	8 bits	16 bits	

Response parameter:

- No parameter. The response is send back after the writing cycle

Table 77. Present Password response format when Error_flag is set

Response SOF	Response_Flags	Error code	CRC16	Response EOF
	8 bits	8 bits	16 bits	

Response parameter:

- Error code as Error_flag is set:
 - 0Fh: other error

Figure 55. Present Password frame exchange between VCD and LRIS2K

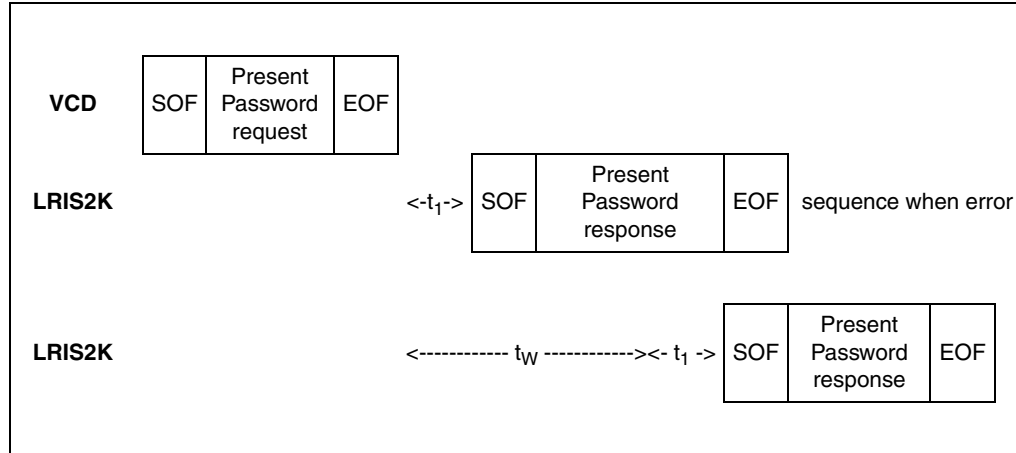

40 Fast Read Single Block

On receiving the Fast Read Single Block command, the LRIS2K reads the requested block and sends back its 32-bit value in the request. The Option_flag is supported. The data rate of the response is multiplied by 2.

Table 78. Fast Read Single Block request format

Request SOF	Request_flags	Fast Read Single Block	IC MFG code	UID	Block number	CRC16	Request EOF
	8 bits	C0h	02h	64 bits	8 bits	16 bits	

Request parameters:

- Option_flag
- UID (optional)
- Block number

Table 79. Fast Read Single Block response format when Error_flag is NOT set

Response SOF	Response_flags	Block Locking Status	Data	CRC16	Response EOF
	8 bits	8 bits	32 bits	16 bits	

Response parameters:

- Block Locking Status if Option_flag is set (see [Table 80](#))
- 4 bytes of block data

Table 80. Block Locking status

b ₇	b ₆	b ₅	b ₄	b ₃	b ₂	b ₁	b ₀
Reserved for future used. All at 0			password control bits		Read / Write protection bits		0: Current Block not locked 1: Current Block locked

Table 81. Fast Read Single Block response format when Error_flag is set

Response SOF	Response_Flags	Error code	CRC16	Response EOF
	8 bits	8 bits	16 bits	

Response parameter:

- Error code as Error_flag is set:
 - 0Fh: other error
 - 10h: block address not available

Figure 56. Fast Read Single Block frame exchange between VCD and LRIS2K

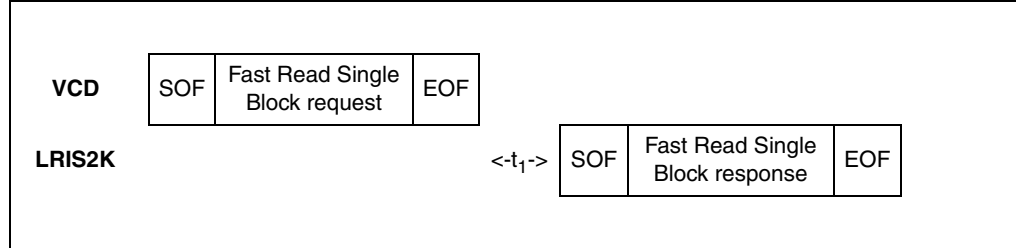

41 Fast Inventory Initiated

Before receiving the Fast Inventory Initiated command, the LRIS2K must have received an Initiate or a Fast Initiate command in order to set the Initiate_ flag. If not, the LRIS2K does not answer to the Fast Inventory Initiated command.

On receiving the Fast Inventory Initiated request, the LRIS2K runs the anticollision sequence. The Inventory_ flag must be set to 1. The meaning of flags 5 to 8 is shown in [Table 19: Request_flags 5 to 8 when Bit 3 = 1](#). The data rate of the response is multiplied by 2.

The request contains the:

- flags
- Inventory command code
- AFI option not supported, AFI_ flag must be set to 0
- mask length
- mask value
- CRC

The LRIS2K does not generate any answer in case of error.

Table 82. Fast Inventory Initiated request format

Request SOF	Request Flags	Fast Inventory Initiated	IC MFG code	Optional AFI	Mask length	Mask value	CRC16	Request EOF
	8 bits	C1h	02h	8 bits	8 bits	0 - 64 bits	16 bits	

The response contains:

- the flags
- the Unique ID

Table 83. Fast Inventory Initiated response format

Response SOF	Response_flags	DSFID	UID	CRC16	Response EOF
	8 bits	00h	64 bits	16 bits	

During an Inventory process, if the VCD does not receive an RF LRIS2K response, it waits a time t_3 before sending an EOF to switch to the next slot. t_3 starts from the rising edge of the request EOF sent by the VCD.

- If the VCD sends a 100% modulated EOF, the minimum value of t_3 is:
 $t_{3min} = 4384/f_C (323.3\mu s) + t_{SOF}$
- If the VCD sends a 10% modulated EOF, the minimum value of t_3 is:
 $t_{3min} = 4384/f_C (323.3\mu s) + t_{NRT}$

where:

- t_{SOF} is the time required by the LRIS2K to transmit an SOF to the VCD
- t_{NRT} is the nominal response time of the LRIS2K

t_{NRT} and t_{SOF} are dependent on the LRIS2K-to-VCD data rate and subcarrier modulation mode.

42 Fast Initiate

On receiving the Fast Initiate command, the LRIS2K sets the internal Initiate_flag and sends back a request. The command has to be issued in the Non Addressed mode only (Select_flag is reset to 0 and Address_flag is reset to 0). If an error occurs, the LRIS2K does not generate any answer. The Initiate_flag is reset after a power off of the LRIS2K. The data rate of the response is multiplied by 2.

The request contains:

- No data

Table 84. Fast Initiate request format

Request SOF	Request_flags	Fast Initiate	IC MFG code	CRC16	Request EOF
	8 bits	C2h	02h	16 bits	

The response contains:

- the flags
- the Unique ID

Table 85. Fast Initiate response format

Response SOF	Response_flags	DSFID	UID	CRC16	Response EOF
	8 bits	00h	64 bits	16 bits	

Figure 57. Fast Initiate frame exchange between VCD and LRIS2K

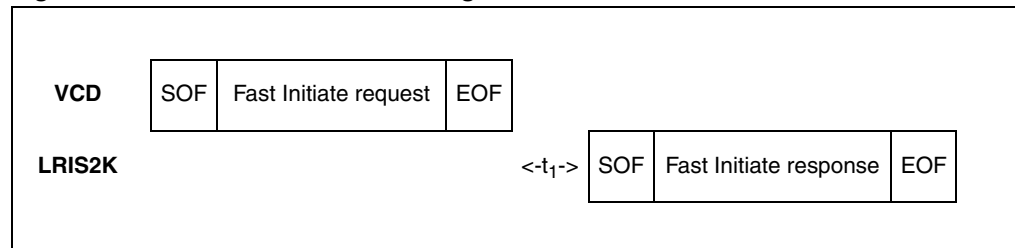

43 Inventory Initiated

Before receiving the Inventory Initiated command, the LRIS2K must have received an Initiate or a Fast Initiate command in order to set the Initiate_ flag. If not, the LRIS2K does not answer to the Inventory Initiated command.

On receiving the Inventory Initiated request, the LRIS2K runs the anticollision sequence. The Inventory_ flag must be set to 1. The meaning of flags 5 to 8 is given in [Table 19: Request_flags 5 to 8 when Bit 3 = 1](#).

The request contains the:

- flags
- Inventory command code
- AFI option not supported, AFI_ flag must be set to 0
- mask length
- mask value
- CRC

The LRIS2K does not generate any answer in case of error.

Table 86. Inventory Initiated request format

Request SOF	Request_flags	Inventory Initiated	IC MFG code	Optional AFI	Mask length	Mask value	CRC16	Request EOF
	8 bits	D1h	02h	8 bits	8 bits	0 - 64 bits	16 bits	

The response contains the:

- flags
- unique ID

Table 87. Inventory Initiated response format

Response SOF	Response_flags	DSFID	UID	CRC16	Response EOF
	8 bits	0x00	64 bits	16 bits	

During an Inventory process, if the VCD does not receive an RF LRIS2K response, it waits a time t_3 before sending an EOF to switch to the next slot. t_3 starts from the rising edge of the request EOF sent by the VCD.

- If the VCD sends a 100% modulated EOF, the minimum value of t_3 is:
 $t_{3min} = 4384/f_C (323.3\mu s) + t_{SOF}$
- If the VCD sends a 10% modulated EOF, the minimum value of t_3 is:
 $t_{3min} = 4384/f_C (323.3\mu s) + t_{NRT}$

where:

- t_{SOF} is the time required by the LRIS2K to transmit an SOF to the VCD
- t_{NRT} is the nominal response time of the LRIS2K

t_{NRT} and t_{SOF} are dependent on the LRIS2K-to-VCD data rate and subcarrier modulation mode.

44 Initiate

On receiving the Initiate command, the LRIS2K sets the internal Initiate_flag and sends back a request. The command has to be issued in the Non Addressed mode only (Select_flag is reset to 0 and Address_flag is reset to 0). If an error occurs, the LRIS2K does not generate any answer. The Initiate_flag is reset after a power off of the LRIS2K.

The request contains:

- No data

Table 88. Initiate request format

Request SOF	Request_flags	Initiate	IC MFG code	CRC16	Request EOF
	8 bits	D2h	02h	16 bits	

The response contains the:

- flags
- unique ID

Table 89. Initiate Initiated response format

Response SOF	Response_flags	DSFID	UID	CRC16	Response EOF
	8 bits	00h	64 bits	16 bits	

Figure 58. Initiate frame exchange between VCD and LRIS2K

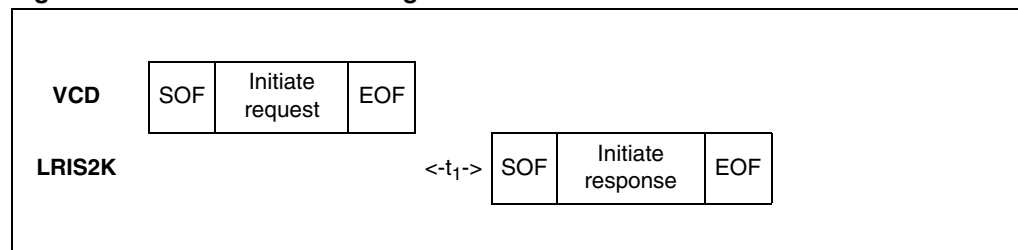

45 Maximum rating

Stressing the device above the rating listed in the absolute maximum ratings table may cause permanent damage to the device. These are stress ratings only and operation of the device at these or any other conditions above those indicated in the operating sections of this specification is not implied. Exposure to absolute maximum rating conditions for extended periods may affect device reliability. Refer also to the STMicroelectronics SURE Program and other relevant quality documents.

Table 90. Absolute maximum ratings

Symbol	Parameter		Min.	Max.	Unit
T_{STG}	Storage conditions	Wafer (kept in its antistatic bag)	15	25	°C
t_{STG}	Storage time			23	months
I_{CC}	Supply current on AC0 / AC1		-20	20	mA
V_{MAX}	Input voltage on AC0 / AC1		-7	7	V
V_{ESD}	Electrostatic discharge voltage ⁽¹⁾	UFDFPN8 (HBM) ⁽²⁾	-1000	1000	V
		UFDFPN8 (MM) ⁽³⁾	-100	100	V

1. AEC-Q100-002 (compliant with JEDEC Std JESD22-A114A, C1=100 pF, R1=1500 Ohm, R2=500 Ohm)

2. Human body model.

3. Machine model.

46 DC and AC parameters

This section summarizes the operating and measurement conditions, and the DC and AC characteristics of the device. The parameters in the DC and AC characteristic tables that follow are derived from tests performed under the measurement conditions summarized in the relevant tables. Designers should check that the operating conditions in their circuit match the measurement conditions when relying on the quoted parameters.

Table 91. AC characteristics^{(1) (2)}

Symbol	Parameter	Condition	Min	Typ	Max	Unit
f_{CC}	External RF signal frequency		13.553	13.56	13.567	MHz
$MI_{CARRIER}$	10% carrier modulation index	$MI=(A-B)/(A+B)$	10		30	%
t_{RFR}, t_{RFF}	10% rise and fall time		0.5		3.0	μs
t_{RFSBL}	10% minimum pulse width for bit		7.1		9.44	μs
$MI_{CARRIER}$	100% carrier modulation index	$MI=(A-B)/(A+B)$	95		100	%
t_{RFR}, t_{RFF}	100% rise and fall time		0.5		3.5	μs
t_{RFSBL}	100% minimum pulse width for bit		7.1		9.44	μs
t_{JIT}	Bit pulse jitter		-2		+2	μs
$t_{MIN CD}$	Minimum time from carrier generation to first data	From H-field min		0.1	1	ms
f_{SH}	Subcarrier frequency high	$F_{CC}/32$		423.75		KHz
f_{SL}	Subcarrier frequency low	$F_{CC}/28$		484.28		KHz
t_1	Time for LRIS2K response	$4224/F_S$	318.6	320.9	323.3	μs
t_2	Time between commands	$4224/F_S$	309	311.5	314	μs
t_W	Programming time (including internal verify time)				5.8	ms

1. $T_A = -20$ to 85 °C.

2. All timing measurements were performed on a reference antenna with the following characteristics:
 External size: 75 mm x 48 mm
 Number of turns: 6
 Width of conductor: 1 mm
 Space between 2 conductors: 0.4 mm
 Value of the tuning capacitor: 21 pF (LRIS2K-SBN18)
 Value of the coil: 4.3 μH
 Tuning frequency: 13.8 MHz.

Table 92. DC characteristics⁽¹⁾

Symbol	Parameter	Test conditions	Min.	Typ.	Max.	Unit
V _{CC}	Regulated voltage		1.5		3.0	V
V _{RET}	Retromodulated induced voltage	ISO10373-7	10			mV
I _{CC}	Supply current	Read	V _{CC} = 3.0 V		50	μA
		Write	V _{CC} = 3.0 V		150	μA
C _{TUN}	Internal tuning capacitor	f = 13.56 MHz for SBN18/1		21		pF

1. T_A = -20 to 85 °C.

Table 93. Operating conditions

Symbol	Parameter	Min.	Max.	Unit
T _A	Ambient operating temperature	-20	85	°C

Figure 59 shows an ASK modulated signal, from the VCD to the LRIS2K. The test condition for the AC/DC parameters are:

- Close coupling condition with tester antenna (1mm)
- LRIS2K performance measured at the tag antenna

Figure 59. LRIS2K synchronous timing, transmit and receive

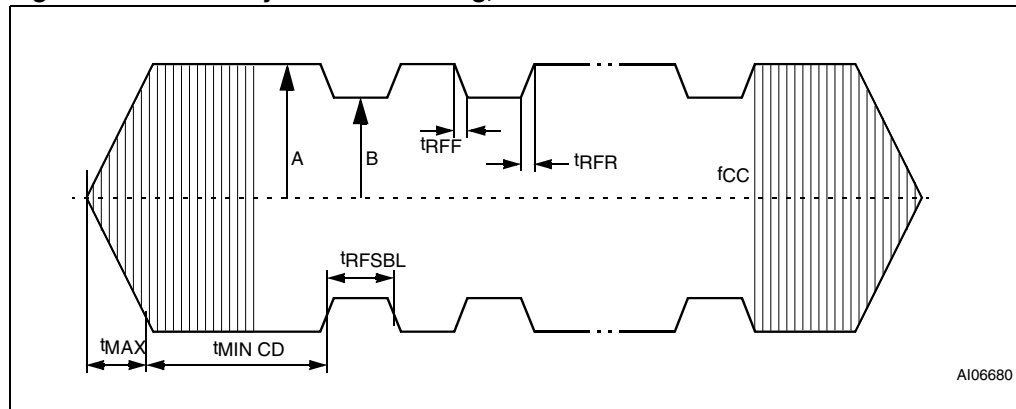

47 Part numbering

Table 94. Ordering information scheme

Example:	LRIS2K	-	SBN18/ 1	GE
Device type	LRIS2K			
Package	SBN18 = 180 μm \pm 15 μm bumped and sawn wafer on 8-inch frame			
Tuning capacitance	1 = 21 pF			
Customer code given by ST	GE			

For further information on any aspect of this device, please contact your nearest ST sales office.

Appendix A Anticollision algorithm (Informative)

The following pseudocode describes how anticollision could be implemented on the VCD, using recursivity.

A.1 Algorithm for pulsed slots

```
function push (mask, address); pushes on private stack
function pop (mask, address); pops from private stack
function pulse_next_pause; generates a power pulse
function store(LRIS2K_UID); stores LRIS2K_UID

function poll_loop (sub_address_size as integer)
  pop (mask, address)
  mask = address & mask; generates new mask
  ; send the request
  mode = anticollision
  send_Request (Request_cmd, mode, mask length, mask value)
  for sub_address = 0 to (2^sub_address_size - 1)
    pulse_next_pause
    if no_collision_is_detected ; LRIS2K is inventoried
      then
        store (LRIS2K_UID)
      else ; remember a collision was detected
        push(mask,address)
      endif
    next sub_address

    if stack_not_empty ; if some collisions have been detected and
      then ; not yet processed, the function calls itself
        poll_loop (sub_address_size); recursively to process the
        last stored collision
      endif
  end poll_loop

main_cycle:
  mask = null
  address = null
  push (mask, address)
  poll_loop(sub_address_size)
end_main_cycle
```

Appendix B CRC (informative)

B.1 CRC error detection method

The cyclic redundancy check (CRC) is calculated on all data contained in a message, from the start of the flags through to the end of data. The CRC is used from VCD to LRIS2K and from LRIS2K to VCD.

Table 95. CRC definition

CRC definition					
CRC type	Length	Polynomial	Direction	Preset	Residue
ISO/IEC 13239	16 bits	$X^{16} + X^{12} + X^5 + 1 = 8408h$	Backward	FFFFh	F0B8h

To add extra protection against shifting errors, a further transformation on the calculated CRC is made. The One's Complement of the calculated CRC is the value attached to the message for transmission.

To check received messages the 2 CRC bytes are often also included in the re-calculation, for ease of use. In this case, the expected value for the generated CRC is the residue F0B8h.

B.2 CRC calculation example

This example in C language illustrates one method of calculating the CRC on a given set of bytes comprising a message.

C-example to calculate or check the CRC16 according to ISO/IEC 13239

```
#define POLYNOMIAL0x8408// x^16 + x^12 + x^5 + 1
#define PRESET_VALUE0xFFFF
#define CHECK_VALUE0xF0B8

#define NUMBER_OF_BYTES4// Example: 4 data bytes
#define CALC_CRC1
#define CHECK_CRC0

void main()
{
    unsigned int current_crc_value;
    unsigned char array_of_databytes[NUMBER_OF_BYTES + 2] = {1, 2, 3,
4, 0x91, 0x39};
    int number_of_databytes = NUMBER_OF_BYTES;
    int calculate_or_check_crc;
    int i, j;
    calculate_or_check_crc = CALC_CRC;
// calculate_or_check_crc = CHECK_CRC;// This could be an other
example
    if (calculate_or_check_crc == CALC_CRC)
    {
```

```
        number_of_databytes = NUMBER_OF_BYTES;
    }
    else    // check CRC
    {
        number_of_databytes = NUMBER_OF_BYTES + 2;
    }

    current_crc_value = PRESET_VALUE;

    for (i = 0; i < number_of_databytes; i++)
    {
        current_crc_value = current_crc_value ^ ((unsigned
int)array_of_databytes[i]);

        for (j = 0; j < 8; j++)
        {
            if (current_crc_value & 0x0001)
            {
                current_crc_value = (current_crc_value >> 1) ^
POLYNOMIAL;
            }
            else
            {
                current_crc_value = (current_crc_value >> 1);
            }
        }
    }

    if (calculate_or_check_crc == CALC_CRC)
    {
        current_crc_value = ~current_crc_value;

        printf ("Generated CRC is 0x%04X\n", current_crc_value);

        // current_crc_value is now ready to be appended to the data
stream
        // (first LSByte, then MSByte)
    }
    else    // check CRC
    {
        if (current_crc_value == CHECK_VALUE)
        {
            printf ("Checked CRC is ok (0x%04X)\n",
current_crc_value);
        }
        else
        {
            printf ("Checked CRC is NOT ok (0x%04X)\n",
current_crc_value);
        }
    }
}
```

Appendix C Application family identifier (AFI) (informative)

The AFI (application family identifier) represents the type of application targeted by the VCD and is used to extract from all the LRIS2K present only the LRIS2K meeting the required application criteria.

It is programmed by the LRIS2K issuer (the purchaser of the LRIS2K). Once locked, it cannot be modified.

The most significant nibble of the AFI is used to code one specific or all application families, as defined in [Table 96](#).

The least significant nibble of the AFI is used to code one specific or all application subfamilies. Subfamily codes different from 0 are proprietary.

Table 96. AFI coding⁽¹⁾

AFI Most significant nibble	AFI Least significant nibble	Meaning VICCs respond from	Examples / Note
'0'	'0'	All families and subfamilies	No applicative preselection
'X'	'0'	'All subfamilies of family X	Wide applicative preselection
'X'	'Y'	Only the Yth subfamily of family X	
'0'	'Y'	Proprietary subfamily Y only	
'1'	"0', 'Y'	Transport	Mass transit, Bus, Airline,...
'2'	"0', 'Y'	Financial	IEP, Banking, Retail,...
'3'	"0', 'Y'	Identification	Access Control,...
'4'	"0', 'Y'	Telecommunication	Public Telephony, GSM,...
'5'	'0', 'Y'	Medical	
'6'	"0', 'Y'	Multimedia	Internet services....
'7'	"0', 'Y'	Gaming	
8	"0', 'Y'	Data Storage	Portable Files,...
'9'	"0', 'Y'	Item Management	
'A'	"0', 'Y'	Express Parcels	
'B'	"0', 'Y'	Postal Services	
'C'	"0', 'Y'	Airline Bags	
'D'	"0', 'Y'	RFU	
'E'	"0', 'Y'	RFU	
'F'	'0', 'Y'	RFU	

1. X = '1' to 'F', Y = '1' to 'F'

Revision history

Table 97. Document revision history

Date	Revision	Changes
13-Jun-2006	1	Initial release.
19-Feb-2007	2	Figure 1.1: Memory mapping added. Only bits set to '1' are programmed to the AFI and DSFID Registers (see Section 30: Write AFI and Section 32: Write DSFID). C_{TUN} typical value for W4/3 modified in Table 92: DC characteristics . Small text changes.
07-Sep-2007	3	23.5 pF internal tuning capacitor (C_{TUN}) value added (see Features on page 1 and Table 92: DC characteristics). V_{ESD} modified for MLP in Table 90: Absolute maximum ratings .
08-Apr-2008	4	Small text changes. Titles of Table 62 and Table 63 modified. Response parameters modified in Section 35: Get Multiple Block Security Status on page 72 . UFDFPN8 package mechanical data updated and dimensions in inches rounded to four decimal digits instead of three in Table 94: UFDFPN8 - 8-lead ultra thin fine pitch dual flat package no lead (MLP) mechanical data
16-Sep-2008	5	LRIS2K products are no longer delivered in A1 inlays and A6 and A7 antennas. Table 94: Ordering information scheme clarified.
24-Oct-2008	6	Section 30: Write AFI and Section 32: Write DSFID : command descriptions modified. Small changes in Table 90: Absolute maximum ratings .

Table 97. Document revision history (continued)

Date	Revision	Changes
15-Dec-2009	7	<p>Note added to Table 2: Memory map.</p> <p>Section 2: LRIS2K block security modified. Table 5: Read / Write protection bit setting and block protection status modified to include also the Password Control bits (Password Control bits table removed), Write Password paragraph modified.</p> <p>Addresses 1 and 2 removed from Table 7: LRIS2K block security protection after power-up and Table 8: LRIS2K block security protection after a valid presentation of password 1.</p> <p>Option_flag specified in Section 25: Read Single Block.</p> <p>Note added to Table 72: Protect status.</p>
30-Sep-2010	8	<p>Removed unsawn wafer (W4) and MLP8 (MBTG).</p> <p>Modified programming time to 5 ms.</p> <p>Removed 23, 28.5, and 97 pF tuning capacitor.</p> <p>Section 36: Kill: UID mandatory, and error code definition.</p> <p>Removed Option_flag in Section 27: Lock Block, Section 30: Write AFI, Section 31: Lock AFI, Section 32: Write DSFID, Section 33: Lock DSFID, Section 36: Kill. Specified Option_flag in Section 35: Get Multiple Block Security Status.</p> <p>Corrected IC reference in Table 59: Get System Info response format when Error_flag is NOT set.</p> <p>AFI_flag not supported by Fast Inventory and Inventory initiated commands (see Section 41: Fast Inventory Initiated, Section 43: Inventory Initiated).</p>

Please Read Carefully:

Information in this document is provided solely in connection with ST products. STMicroelectronics NV and its subsidiaries ("ST") reserve the right to make changes, corrections, modifications or improvements, to this document, and the products and services described herein at any time, without notice.

All ST products are sold pursuant to ST's terms and conditions of sale.

Purchasers are solely responsible for the choice, selection and use of the ST products and services described herein, and ST assumes no liability whatsoever relating to the choice, selection or use of the ST products and services described herein.

No license, express or implied, by estoppel or otherwise, to any intellectual property rights is granted under this document. If any part of this document refers to any third party products or services it shall not be deemed a license grant by ST for the use of such third party products or services, or any intellectual property contained therein or considered as a warranty covering the use in any manner whatsoever of such third party products or services or any intellectual property contained therein.

UNLESS OTHERWISE SET FORTH IN ST'S TERMS AND CONDITIONS OF SALE ST DISCLAIMS ANY EXPRESS OR IMPLIED WARRANTY WITH RESPECT TO THE USE AND/OR SALE OF ST PRODUCTS INCLUDING WITHOUT LIMITATION IMPLIED WARRANTIES OF MERCHANTABILITY, FITNESS FOR A PARTICULAR PURPOSE (AND THEIR EQUIVALENTS UNDER THE LAWS OF ANY JURISDICTION), OR INFRINGEMENT OF ANY PATENT, COPYRIGHT OR OTHER INTELLECTUAL PROPERTY RIGHT.

UNLESS EXPRESSLY APPROVED IN WRITING BY AN AUTHORIZED ST REPRESENTATIVE, ST PRODUCTS ARE NOT RECOMMENDED, AUTHORIZED OR WARRANTED FOR USE IN MILITARY, AIR CRAFT, SPACE, LIFE SAVING, OR LIFE SUSTAINING APPLICATIONS, NOR IN PRODUCTS OR SYSTEMS WHERE FAILURE OR MALFUNCTION MAY RESULT IN PERSONAL INJURY, DEATH, OR SEVERE PROPERTY OR ENVIRONMENTAL DAMAGE. ST PRODUCTS WHICH ARE NOT SPECIFIED AS "AUTOMOTIVE GRADE" MAY ONLY BE USED IN AUTOMOTIVE APPLICATIONS AT USER'S OWN RISK.

Resale of ST products with provisions different from the statements and/or technical features set forth in this document shall immediately void any warranty granted by ST for the ST product or service described herein and shall not create or extend in any manner whatsoever, any liability of ST.

ST and the ST logo are trademarks or registered trademarks of ST in various countries.

Information in this document supersedes and replaces all information previously supplied.

The ST logo is a registered trademark of STMicroelectronics. All other names are the property of their respective owners.

© 2010 STMicroelectronics - All rights reserved

STMicroelectronics group of companies

Australia - Belgium - Brazil - Canada - China - Czech Republic - Finland - France - Germany - Hong Kong - India - Israel - Italy - Japan - Malaysia - Malta - Morocco - Philippines - Singapore - Spain - Sweden - Switzerland - United Kingdom - United States of America

www.st.com