

Features and Benefits

Conforms with ISO/IEC 14443A⁽¹⁾
 Conforms with ISO/IEC 15693
 Compatible with Tag-it™⁽²⁾ transponders
 Low external component count

Application Examples

Portable data terminals
 Access control readers
 Contact-less payment terminals
 Smart label printers

Ordering Information

Part No.	Temperature Suffix	Package Code	Option code
MLX12115	E (-40°C to 85°C)	FR (Lead free SSOP20, 2 09 mils)	--

1. Functional Diagram

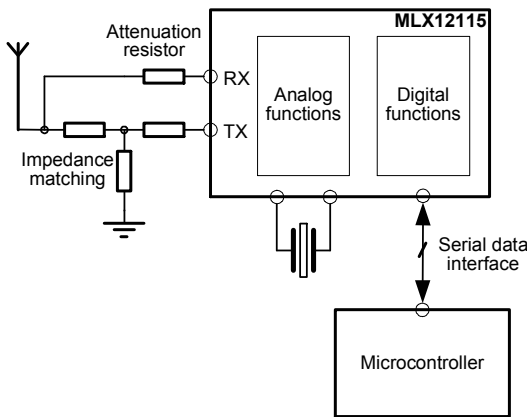

The main features include user selectable modulation depth in write mode, whereas single sub-carrier ASK and FSK modulations are recognized in the read mode.

Its low power consumption enable design of portable and fixed reader designs requiring tight footprint constraints. The IC minimizes onboard power requirements and reduces parts count in a final reader product.

With the addition of a micro-processor, crystal, and a few passive components a full functioning reader can be easily developed.

It can provide up to 200 milliwatts of RF power to a 50 ohms load with a 5 volts power supply using the recommended matching network. This is suitable for most short to mid range applications.

A simplified antenna and matching network can be used, at the expense of a reduced reading range, for example in hand-held reader applications.

The chip is configured with a serial interface. A synchronization signal is available when the majority voting is used.

2. Description

The MLX12115 is an ISO compliant 13.56MHz RFID transceiver integrated circuit.

It can be used as a drop-in replacement of Texas Instruments' S6700. The device supports multiple RF air interfaces, such as Tag-it™⁽²⁾, ISO15693 and ISO14443A⁽¹⁾ and opens with the direct mode where data can be passed directly to a transponder.

⁽¹⁾ Purchase of MLX12115s doesn't imply any grant of any ISO14443A license. Customers are advised to sign patent licensing agreements with all third parties, especially those companies listed in the introduction of the corresponding standard.

⁽²⁾ Purchase of MLX12115s doesn't imply any grant of any Tag-it™ license. Customers are advised to sign patent licensing agreements with Texas Instruments. Tag-it™ is a trademark of Texas Instruments Incorporated

Table of Contents

1. FUNCTIONAL DIAGRAM.....	1-1
2. DESCRIPTION.....	2-1
3. GLOSSARY OF TERMS	3-3
4. ABSOLUTE MAXIMUM RATINGS	4-3
5. ELECTRICAL SPECIFICATIONS	5-3
6. BLOCK DIAGRAM	6-6
7. PIN DEFINITIONS AND DESCRIPTIONS	7-6
8. ESD PRECAUTIONS.....	8-6
9. RELIABILITY INFORMATION.....	9-7
10. PACKAGE INFORMATION.....	10-8
11. DISCLAIMER.....	11-9

3. Glossary of Terms

RFID	Radio Frequency IDentification
ISO	International Organization for Standardization / International Electro-technical Commission.
AM	Amplitude Modulation
FM	Frequency Modulation
ASK	Amplitude Shift Keying
FSK	Frequency Shift Keying

4. Absolute Maximum Ratings

Parameter	Symbol	Condition	Min	Max	Unit
Supply voltage (V_{DD} with respect to V_{SS})	V_{DD}	DC	-0.3	6	V
Input voltage on any pin (except TX)	V_{in}		-0.3	$V_{DD}+0.3$	V
Maximum power dissipation (without heat sink)	P_{max}			500	mW
Maximum junction temperature	T_j			+150	°C
Storage temperature	T_{stor}		-55	+150	°C

Exceeding the absolute maximum ratings may cause permanent damage. Exposure to absolute-maximum-rated conditions for extended periods may affect device reliability.

5. Electrical Specifications

$T_A = -40\text{ °C}$ to $+85\text{ °C}$, $V_{DD} = 5\text{ Volts}$, unless otherwise noted.
On board resonator is used.

General DC Parameters						
Parameter	Symbol	Test Conditions	Min	Typ	Max	Units
Operating supply voltage range	V_{DD}	V_{DD} with respect to V_{SS}	3	5	5.5	V
Standby current consumption	I_{stb}	$V_{DD} = 5.5\text{ V}$		1	50	μA
Idle mode current consumption	I_{dle}	$V_{DD} = 5.5\text{ V}$ - Analog section off		12	15	mA
Operating Current	I_{op}	$V_{DD} = 5.5\text{ V}$		14	19	mA
Transmit current	I_{tr}	50 Ohms load		80	120	mA

Transmitter specifications					
Parameter	Test Conditions	Min	Typ	Max	Units
Peak voltage applied on drain of output transistor				32	V
Output transistor power dissipation				500	mW
Output transistor ON resistance	$I_d = 50 \text{ mA}$		2	5	Ω
Output power for five volts operation	See note 1		200		mW
Amplitude modulation depth adjustment range, in 10% mode, with external resistor connected between RMOD pin and ground.	See note 1	0		90	%
Amplitude modulation depth in 10% mode with nominal external resistor (10 Ω)	See note 1	10	12	16	%
Minimum depth for 100% ASK	See note 1	40			dB
Rise and Fall time for 100% ASK	See note 1		2.5	4	μs
Rise and fall time for 10% modulation depth (nominal external resistor used)	See note 1		1	1.5	μs

Receiver specifications					
Parameter	Test Conditions	Min	Typ	Max	Units
Small signal input impedance (RX)			100		k Ω
Input RF voltage range (RX_IN – V _{SS})	With 1k Ω series external resistor	1	1.8-4.9	V _{DD}	V
Receiver sensitivity	See note 1	-40	-65		dBm
FSK IF filter cut off points		130	200-1400	1800	kHz
Gain, in FSK mode (FM output)			120		dB
Gain, in ASK mode (AM output)			80		dB

Serial link and digital I/O						
Parameter	Symbol	Test Conditions	Min	Typ	Max	Units
Output current drive	I_{ol}	$V_{ol} \leq 0.4 \text{ Volt}$	1			mA
Output voltage low	V_{ol}	$I_{ol \text{ max}} = 4 \text{ mA}$	0	0.2	0.4	V
Output voltage high	V_{oh}	$I_{oh \text{ max}} = 4 \text{ mA}$	4.6	4.8	5	V
Input voltage high	V_{ih}		$0.7 * V_{DD}$		$V_{DD} + 0.3 \text{ V}$	V
Input voltage low	V_{il}		-0.3		$0.3 * V_{DD}$	V
SCK frequency	f_{CK}				1.5	MHz

Crystal Oscillator						
Parameter	Symbol	Test Conditions	Min	Typ	Max	Units
Frequency range	F _{xtal}	ISO compliant applications		13.56		MHz
Start-up time	T _{start}			2	5	ms
Xtal series resistance	R _{xtal}			50	100	Ω

External clock signal specifications (see note 2)						
Parameter	Test Conditions	Min	Typ	Max	Units	
Min sine wave amplitude, AC coupled Input on pin XTAL2		1		V _{DD}	V _{PP}	
Min sine wave amplitude, DC coupled Input on pin XTAL2	Input has to be centered around V _{DD} /2	1		V _{DD}	V _{PP}	

XBUF output specifications						
Parameter	Test Conditions	Min	Typ	Max	Units	
XBUF Low Level (Col)	1K load resistor	0	0.2	0.4	V	
XBUF High Level (Coh)	1K load resistor	4.6	4.8	5.0	V	
Rise and fall times (10%-90%)	1K load resistor//12pF		3		ns	

Notes

1. Parameter measured using adapted output matching network.
2. The external clock symmetry is of paramount importance. It has a direct influence on the transmitter output power. When using a sine wave as external clock input, it must not show visible distortion. In case a square wave is used, its duty cycle has to be equal to 50%.

6. Block Diagram

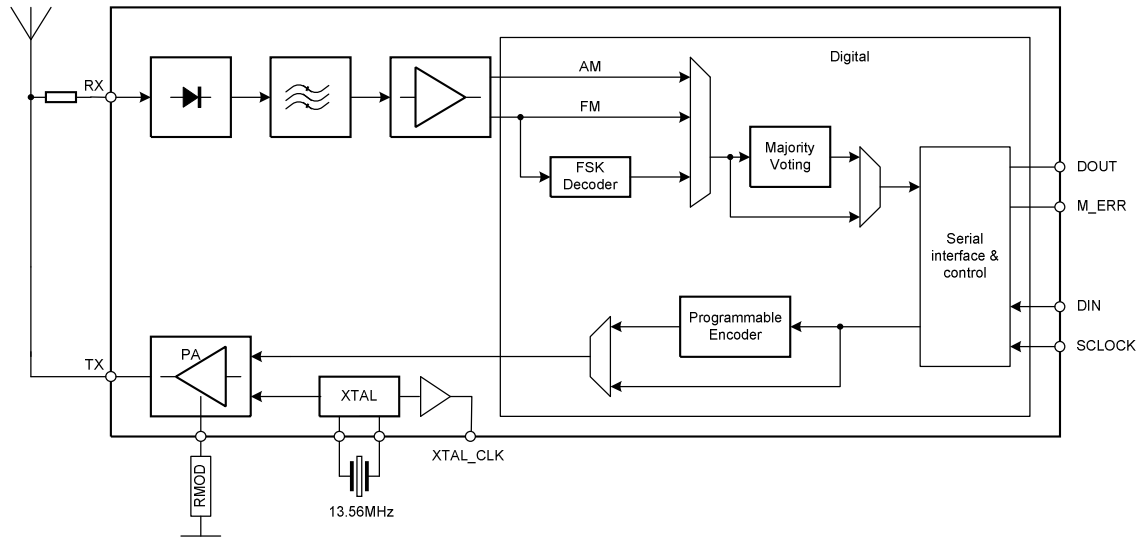

7. Pin Definitions and Descriptions

The device is packaged in a 20 pin lead free SSOP package.

	Pin Number	Name	Description
	1	VDD_TX	Transmitter power supply
	2	TX_OUT	Output transistor drain connection
	3	R_MOD	External resistor to set 10% modulation depth mode
	4	VSS_TX	Transmitter section ground
	5	XTAL1	Pin 1 of Xtal resonator
	6	XTAL2	Pin 2 of Xtal resonator and external system clock input
	7	VSS_DIG	Digital section ground
	8	XTAL_CLK	Buffered output of Xtal oscillator
	9	NU	Not Used (Grounded for normal operation)
	10	NU	Not Used (Grounded for normal operation)
	11	DOUT	Data output for serial link
	12	VDD_DIG	Digital section power supply
	13	DIN	Data input for serial link
	14	M_ERR	Manchester Protocol error flag
	15	SCLOCK	Serial link clock
	16	NC	Not Connected (Leave open for normal operation)
	17	VDD_RX	Receiver section power supply
	18	NC	Not Connected (Leave open for normal operation)
	19	VSS_RX	Receiver section ground
	20	RX_IN	Receiver input

8. ESD Precautions

Electronic semiconductor products are sensitive to Electro Static Discharge (ESD). Always observe Electro Static Discharge control procedures whenever handling semiconductor products.

9. Reliability Information

Standard information regarding manufacturability of Melexis products with different soldering processes

Our products are classified and qualified regarding soldering technology, solderability and moisture sensitivity level according to following test methods:

Reflow Soldering SMD's (Surface Mount Device)s

- IPC/JEDEC J-STD-020
Moisture/Reflow Sensitivity Classification for Nonhermetic Solid State Surface Mount Devices (classification reflow profiles according to table 5-2)
- EIA/JEDEC JESD22-A113
Preconditioning of Nonhermetic Surface Mount Devices Prior to Reliability Testing (reflow profiles according to table 2)

Wave Soldering SMD's (Surface Mount Device)s and THD's (Through Hole Device)s

- EN60749-20
Resistance of plastic- encapsulated SMD's to combined effect of moisture and soldering heat
- EIA/JEDEC JESD22-B106 and EN60749-15
Resistance to soldering temperature for through-hole mounted devices

Iron Soldering THD's (Through Hole Device)s

- EN60749-15
Resistance to soldering temperature for through-hole mounted devices

Solderability SMD's (Surface Mount Device)s and THD's (Through Hole Device)s

- EIA/JEDEC JESD22-B102 and EN60749-21
Solderability

For all soldering technologies deviating from above mentioned standard conditions (regarding peak temperature, temperature gradient, temperature profile etc) additional classification and qualification tests have to be agreed upon with Melexis.

The application of Wave Soldering for SMD's is allowed only after consulting Melexis regarding assurance of adhesive strength between device and board.

Melexis is contributing to global environmental conservation by promoting **lead free** solutions. For more information on qualifications of **RoHS** compliant products (RoHS = European directive on the Restriction Of the use of certain Hazardous Substances) please visit the quality page on our website:
<http://www.melexis.com/quality.aspx>

10. Package Information

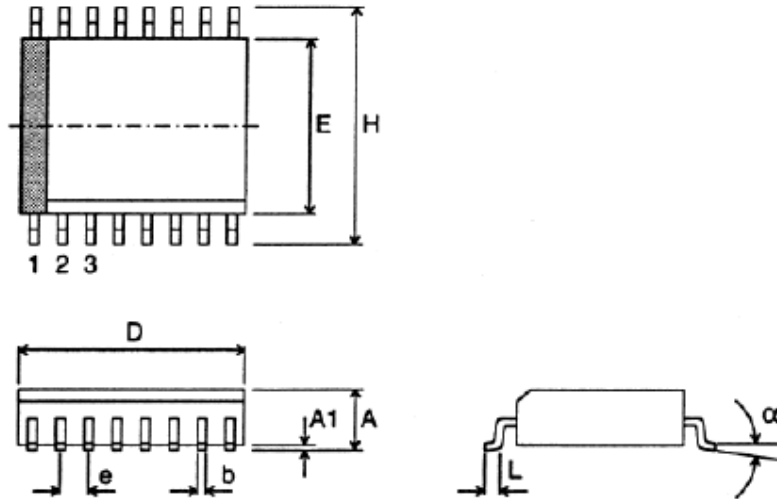

Shrink Small Outline Package (SSOP)

SSOP 20, 24, 28

Package type		D	E	H	A	A 1	e	b	L	α	Package Code
SSOP 20	min	6.60	5.00	7.40		0.05		0.22	0.63	0°	FR20
	max	7.50	5.60	8.20	2.13	0.25	0.65	0.38	1.03	8°	
SSOP 24	min	7.90	5.00	7.40		0.05		0.22	0.63	0°	FR24
	max	8.50	5.60	8.20	2.13	0.25	0.65	0.38	1.03	8°	
SSOP 28	min	9.90	5.00	7.40		0.05		0.22	0.63	0°	FR28
	max	10.50	5.60	8.20	2.13	0.25	0.65	0.38	1.03	8°	

Dimension: mm, coplanarity < 0,1 mm, original dimension: inch

11. Disclaimer

- 1) The information included in this documentation is subject to Melexis intellectual and other property rights. Reproduction of information is permissible only if the information will not be altered and is accompanied by all associated conditions, limitations and notices.
- 2) Any use of the documentation without the prior written consent of Melexis other than the one set forth in clause 1 is an unfair and deceptive business practice. Melexis is not responsible or liable for such altered documentation.
- 3) The information furnished by Melexis in this documentation is provided 'as is'. Except as expressly warranted in any other applicable license agreement, Melexis disclaims all warranties either express, implied, statutory or otherwise including but not limited to the merchantability, fitness for a particular purpose, title and non-infringement with regard to the content of this documentation.
- 4) Notwithstanding the fact that Melexis endeavors to take care of the concept and content of this documentation, it may include technical or factual inaccuracies or typographical errors. Melexis disclaims any responsibility in connection herewith.
- 5) Melexis reserves the right to change the documentation, the specifications and prices at any time and without notice. Therefore, prior to designing this product into a system, it is necessary to check with Melexis for current information.
- 6) Melexis shall not be liable to recipient or any third party for any damages, including but not limited to personal injury, property damage, loss of profits, loss of use, interrupt of business or indirect, special incidental or consequential damages, of any kind, in connection with or arising out of the furnishing, performance or use of the information in this documentation.
- 7) The product described in this documentation is intended for use in normal commercial applications. Applications requiring operation beyond ranges specified in this documentation, unusual environmental requirements, or high reliability applications, such as military, medical life-support or life-sustaining equipment are specifically not recommended without additional processing by Melexis for each application.
- 8) Any supply of products by Melexis will be governed by the Melexis Terms of Sale, published on www.melexis.com.

© Melexis NV. All rights reserved.

For the latest version of this document, go to our website at:

www.melexis.com

Or for additional information contact Melexis Direct:

Europe, Africa:	Americas:	Asia:
Phone: +32 1367 0495	Phone: +1 603 223 2362	Phone: +32 1367 0495
E-mail: sales_europe@melexis.com	E-mail: sales_usa@melexis.com	E-mail: sales_asia@melexis.com

ISO/TS 16949 and ISO14001 Certified