

HP SERIES-II TRANSMITTER MODULE DESIGN GUIDE

DESCRIPTION:

The HP Series-II transmitter module is designed for the cost-effective, high-performance wireless transfer of analog or digital data, in the popular 902-928MHz band. The transmitter offers eight selectable channels and, when paired with an HP Series-II receiver, is capable of transmitting analog and digital information for distances of up to 1000 ft. (under optimal conditions). To assure robust performance, the transmitter employs FM/FSK modulation and an advanced microprocessor-controlled synthesized architecture. Like all Linx modules, the HP Series-II requires no tuning and in most cases no external RF components (*except an antenna*), making integration straightforward even for engineers lacking previous RF experience.

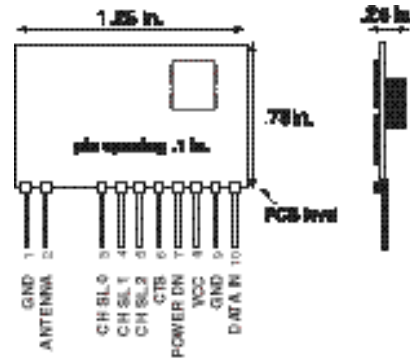


Figure 1: Physical Dimensions

FEATURES:

- 8 Binary Selectable Transmission Frequencies
- FM/FSK Modulation For Noise Immunity
- Cost-Effective
- Precision Synthesized Frequency Reference
- Direct Analog/Serial Interface
- High Data Rate (50Kbps max.)
- Can Be Used To Transmit Analog (Including Audio) or Digital Data
- Wide Supply Range (2.7-16V DC)
- Power-Down & CTS Functions
- No Production Tuning
- No External RF Components Required (Except Antenna)
- FCC Compliant Output Power (0dBm typical)

APPLICATIONS INCLUDE:

- Continuous Data Transfer
- Home/Industrial Automation
- Wireless Networking
- Remote Control
- Remote Access
- Remote Monitoring/Telemetry
- Fire/Security Alarms
- Long-Range RFID
- High-Quality Wireless Audio
- Analog Signal Transfer
- General Wire Elimination

ORDERING INFORMATION

PART #	DESCRIPTION
MDEV-900-HP-II	Evaluation Kit 900 MHz
TXM-900-HP-II	Transmitter 900 MHz
RXM-900-HP-II	Receiver 900 MHz

PERFORMANCE DATA TXM-900-HP-II

ABOUT THESE MEASUREMENTS

The performance parameters listed below are based on module operation at 25°C from a 5VDC supply unless otherwise noted.

Parameter	Designation	Min.	Typical	Max.	Units	Notes
Input Voltage (Vcc)	V _{CC}	2.7	–	16.0	VDC	–
Supply current	I _{CC}	–	15	17	mA	–
Sleep current	I _{CS}	–	–	50	µA	–
Operating frequency	F _C	902	–	928	MHz	–
Overall frequency accuracy		-50	–	+50	KHz	–
Output Power		-3	0	+4	dBm	–
Spurious Emissions		–	–	-50	dBc	1
Harmonic Emissions		–	–	-50	dBc	–
Occupied Bandwidth		–	32	–	KHz	–
PON to CTS High Time	T _{PON}	–	8	12	mSec	–
Minimum Off	T _{MINOFF}	1	–	–	mSec	–
Channel Change Time	Time	–	–	1.2	mSec	–
Fdev		50	75	95	KHz p-p	–

Figure 2: Performance data table

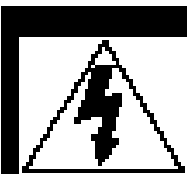
Notes:

1. Tested to 2nd Harmonic

Absolute Maximum Ratings:			
Supply voltage Vcc, using pin 7	-0.3	to	+18 VDC
Operating temperature	0°C	to	+70°C
Storage temperature	-45°C	to	+85°C
Soldering temperature	+260°C for 10 sec.		
Any input or output pin	-0.3	to	Vcc

NOTE Exceeding any of the limits of this section may lead to permanent damage of the device. Furthermore, extended operation at these maximum ratings may reduce the life of this device.

Figure 3: Maximum ratings table



CAUTION

This product incorporates numerous static-sensitive components. Always wear an ESD wrist strap and observe proper ESD handling procedures when working with this device. Failure to observe this precaution may result in module damage or failure.

TYPICAL PERFORMANCE GRAPHS

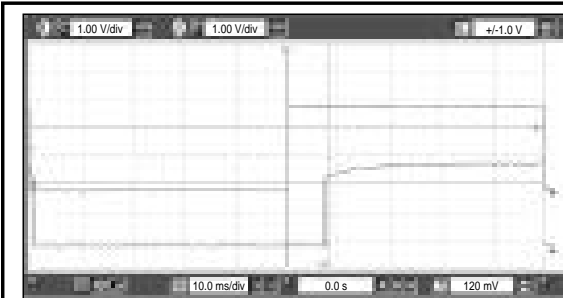


Figure 4: Power-On Timing

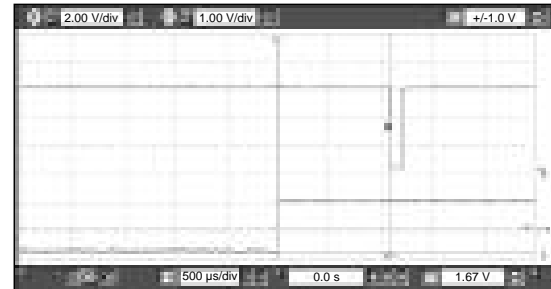


Figure 5: Channel Change Timing

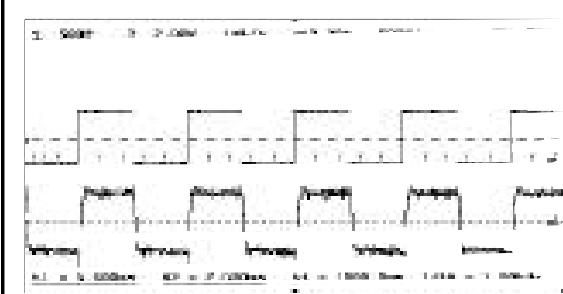


Figure 6: Modulation Linearity for Square Wave Input

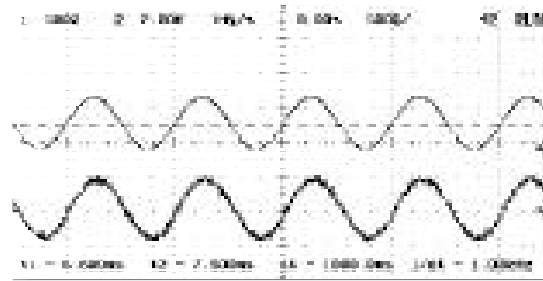


Figure 7: Modulation Linearity for Sine Wave Input

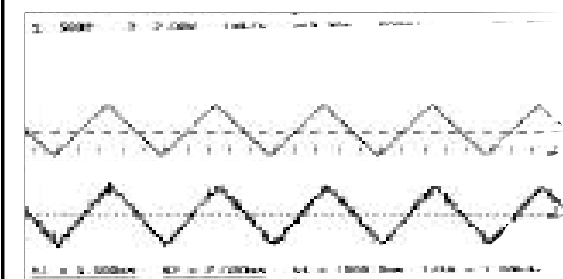


Figure 8: Modulation Linearity for Triangle Wave Input

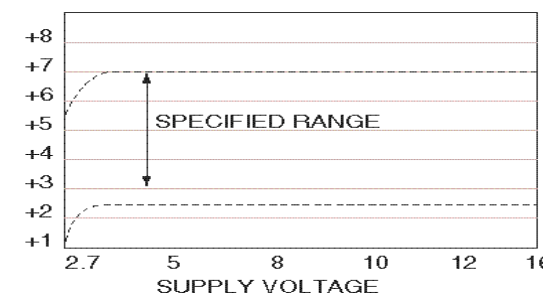


Figure 9: Output Power vs. Supply Voltage

PHYSICAL PACKAGING

The transmitter is packaged as a hybrid through-hole SIP-style module with 10 pins spaced at .1" intervals with a .3" gap between pins 2 & 3. Baseband components occupy the rear of the board while high-frequency components are grouped on the front.

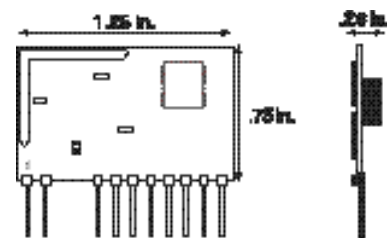


Figure 10: Physical package

PRODUCTION CONSIDERATIONS

The SIP module may be installed using hand- or wave-solder techniques. The module should not be subjected to reflow. If the module is subject to production wash cycles, adequate drying time should be allowed prior to power-up. If the wash cycle introduces contaminants, the module's performance may be adversely affected.

PIN DESCRIPTION

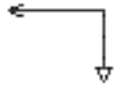
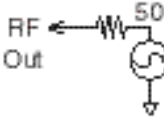
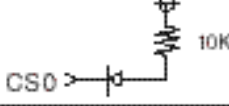
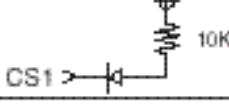
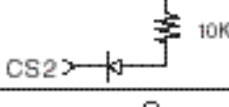
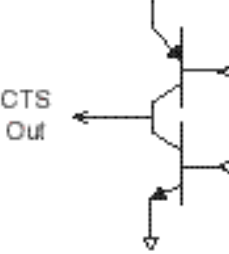
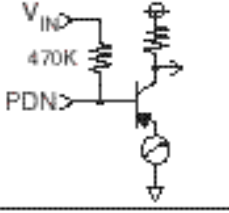

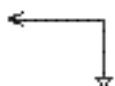
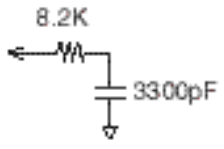
PIN#	PIN Name	Equivalent CTK	Description
1	GND		Analog Ground
2	RF/ANT Out		50 Ohm RF Output
3	CS0		Channel Select 0
4	CS1		Channel Select 1
5	CS2		Channel Select 2
6	CTS		Clear-to-Send Output
7	PDN		Power down (Active Low)
8	VCC		Voltage Input 2.7-16V
9	GND		Digital Ground
10	Analog In/Data In		Digital/Analog Input 0-3V 0-5V See text "Inputting Digital Data"

Figure 11: Pin functions and equivalent circuits

THEORY OF OPERATION

The HP-II-TXM is a high-performance, eight-channel, FM transmitter capable of transmitting analog or digital data.

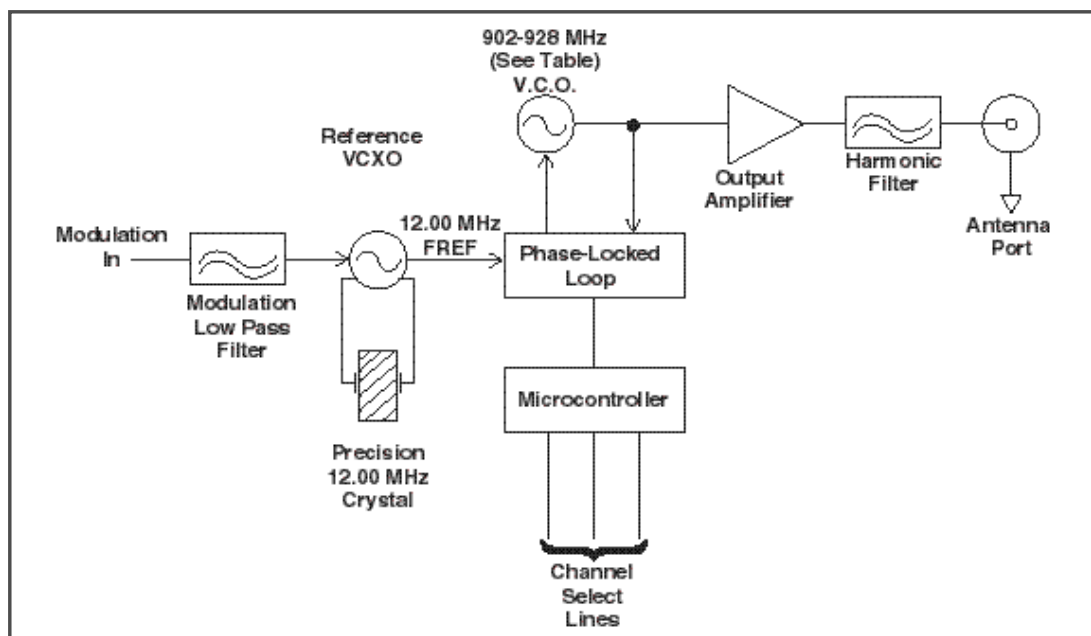


Figure 12: HP Series-II transmitter block diagram

Digital information is modulated at the transmitter using FSK (frequency shift keying), the binary form of frequency modulation. FSK offers significant advantages over AM-based modulation methods, i.e., increased noise immunity and the ability of the receiver to “capture” in the presence of multiple signals. These advantages will be particularly appreciated in crowded bands like those in which the HP-II operates. While FSK modulation is not the most bandwidth-efficient manner of modulating digital data, it is an excellent choice for reliable, low-cost, low-power RF products such as the HP Series-II.

To transmit analog information the module reverts to FM modulation. In this mode simple to complex waveforms can be introduced at the transmitter’s data pin and recovered with minimal distortion at the receiver’s analog output pin.

The user-supplied antenna is connected at pin 2 (see Figure 1). The HP Series-II transmitters are designed to operate with a 50-ohm load.

An accurate 12.00MHz VCXO (voltage-controlled crystal oscillator) serves as the frequency reference for the transmitter. The modulation input pin is connected to the VCXO through a two-pole low-pass filter. The low-pass filter is used to shape the incoming data and limit the transmission bandwidth to 25kHz.

The reference frequency is directly modulated. This method affords two benefits. First, it eliminates the need for a frequency conversion in the transmitter, reducing size, cost, and current consumption. Second, it allows the modulation to occur within the loop bandwidth of the frequency synthesizer allowing a wide modulation bandwidth of 50Hz to 25kHz.

The modulated 12.00MHz reference frequency is applied to the Phase-Locked Loop (PLL). The PLL, combined with a 902-928MHz VCO, forms a stable frequency synthesizer that can be programmed to oscillate at a number of preset frequencies.

An on-board micro-controller reads the channel-selection lines and programs the PLL to the desired channel frequency. The micro-controller also monitors the status of the PLL and indicates when the transmitter is stable and ready to transmit data by asserting the CTS line high.

A buffer amplifier is used to isolate the VCO from the antenna and to increase the output power of the transmitter. The output of the buffer amplifier is connected to a LPF which is used to suppress harmonic emissions. All harmonic specifications are based on a 50-ohm load.

BOARD LAYOUT CONSIDERATIONS

If you are at all familiar with RF devices you may be concerned about specialized layout requirements. Fortunately, because of the care taken by Linx in the layout of the module's PCB, integrating an HP Series-II transmitter into your design is very straightforward. By adhering carefully to a few basic design and layout rules, you can enjoy a trouble-free path to RF success.

A ground-plane (as large as possible) should be placed directly under the HP-II transmitter. This ground-plane can also be critical to the performance of your antenna.

The HP-II transmitter should, as much as reasonably possible, be isolated from all other components on your PCB. Specifically, high-frequency circuitry such as crystal oscillators should be kept as far away as possible from the transmitter module.

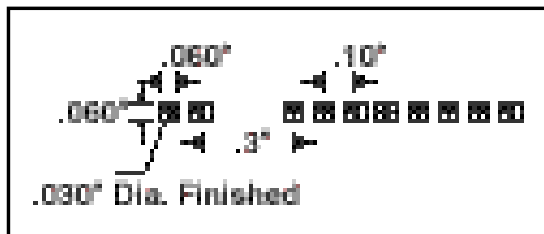


Figure 13: HP Series-II transmitter footprint

If the transmitter must be mounted horizontally, it should be laid over so that the side with the crystal is closest to the user's PC board and the RF side is facing away from the PC board.

The trace from the receiver to the antenna should be kept as short as possible. A simple trace is suitable for runs up to 1/8 inch for monopole antennas with wide bandwidth characteristics. For longer runs or to avoid detuning a narrow bandwidth antenna such as a helical, use a 50-ohm coax or 50-ohm microstrip transmission line as shown in Figure 14.

Observant designers will notice that the output power of the HP Series-II is set 5-6dB above Part 15 limits (assuming the use of a unity antenna). This is done purposefully to allow designers with less efficient antennas to achieve the

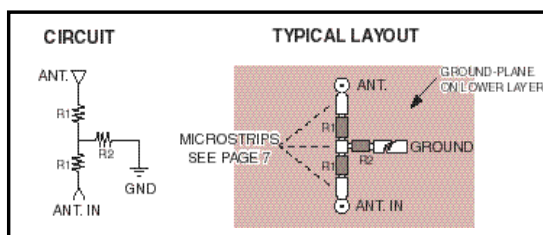


Figure 13A: Attenuation pad layout

maximum output power allowed by law. In cases where an efficient antenna style such as a whip is utilized, it is often necessary to make provisions for external attenuation. This is easily accomplished by providing pads for a three-resistor attenuation network as shown in fig. 13A. The inline pads may be bridged if the network is not needed. The resistors should be a surface-

mount type. They should be grouped closely and the overall trace to the antenna kept as short as possible. Calculate the feed-trace width as shown under the “Microstrip Details” section of this manual and the trace should pass over a suitable ground-plane. Further details regarding T-pad values can be found in application note #00150 - “Use and Design of T-Attenuation Pads”.

MICROSTRIP DETAILS

A transmission line is a medium whereby RF energy is transferred from one place to another with minimal loss. This is a critical factor, particularly in high-frequency products like the HP-II because the trace leading to the module’s antenna can effectively contribute to the length of the antenna, changing its resonant bandwidth. In order to minimize loss and detuning, some form of transmission line between the antenna and the module is needed, unless the antenna connection can be made in close proximity: <1/8 in. to the module. One common form of transmission line is coax cable, another is the *microstrip*. The term refers to a PCB trace running over a ground-plane which is designed to serve as a transmission line between the module and the antenna. The width is based on the desired characteristic impedance, the thickness of the PCB, and its dielectric constant. The correct trace width can be easily calculated using the information below.

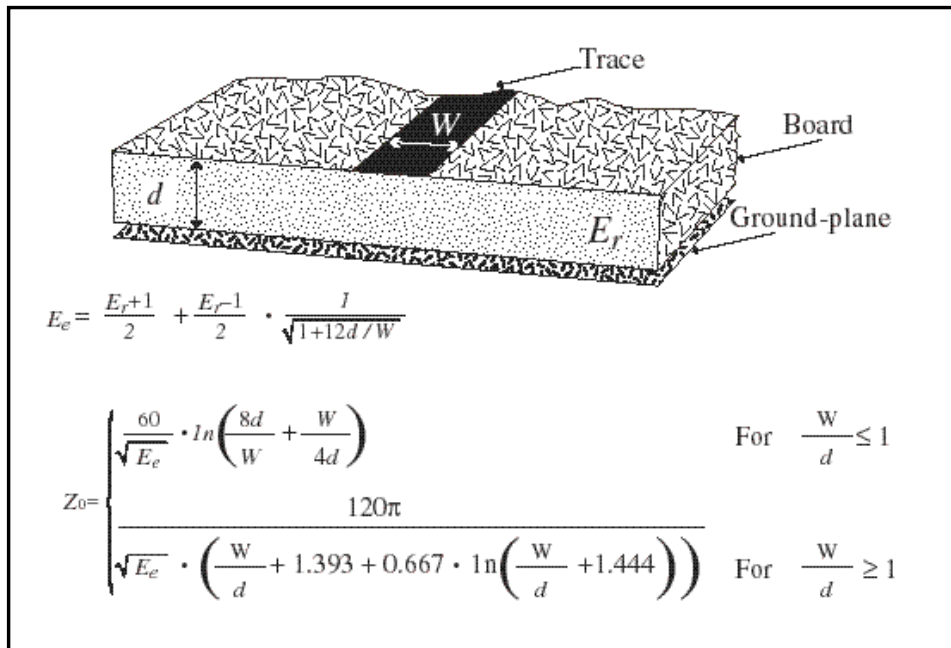


Figure 14: Microstrip formulas (E_r = Dielectric constant of pc board material)

Dielectric Constant	Width/Height (W/d)	Effective Dielectric Constant	Characteristic Impedance
4.8	1.8	3.59	50.0
4	2	3.07	51.0
2.55	3	2.12	48.0

POWER CONSIDERATIONS

The user must provide a clean source of power to the transmitter module in order to ensure proper operation. The transmitter incorporates a precision Low-Dropout Regulator on-board which allows the module to operate over an input voltage range of 2.7 to 16 volts DC. The module's power-supply line should have low ESR bypass capacitors configured as shown in figure 15.

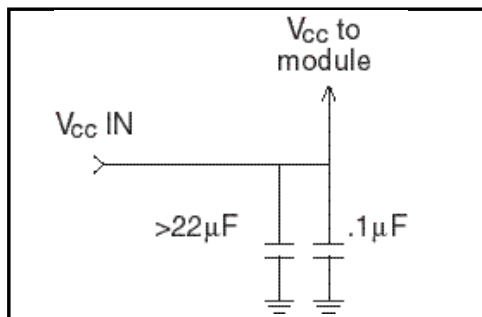


Figure 15: Suggested supply filter

POWER-UP

The HP-II-TXM is controlled by an on-board microprocessor. When power is applied, a start-up sequence is executed. At the end of the start-up sequence, the transmitter is ready to transmit data.

Figure 16 shows the start-up sequence. This sequence is executed when power is applied to the VCC pin or when the PDN pin is cycled from low to high.

Once the initial power-on delay has been executed, the on-board microprocessor reads the external channel-selection lines and sets the frequency synthesizer to the appropriate channel. Figure 4 on p. 3 shows the typical turn-on response time for an HP Series-II transmitter. When the frequency synthesizer has locked on to the proper channel frequency, the circuit is ready to accept data. This is acknowledged by the CTS line transitioning high.

The transmitter is then ready to accept modulated data from a user's circuit.

The HP-II-TXM can be put into an ultra-low-current (50μA) power-down mode by holding the PDN pin low. This removes all power from the transmitter's circuitry. If PDN is left floating or held high, the transmitter will wake up and begin normal operation. No transmitter functions work when PDN is low.

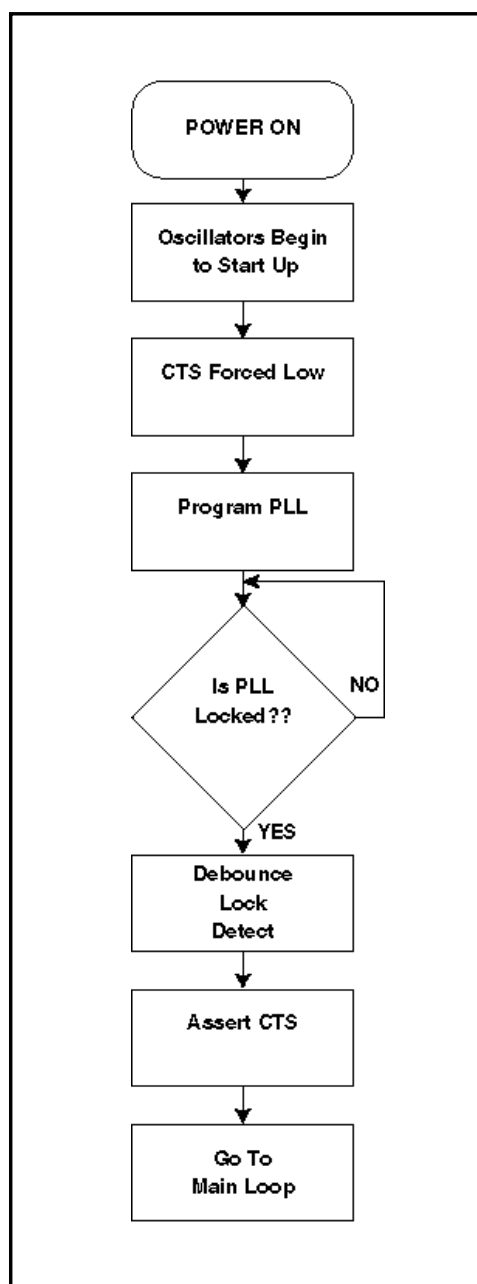


Figure 16: Start-up sequence

NOTE: READ THIS IF YOU ARE GOING TO PERIODICALLY POWER DOWN THE TRANSMITTER!!

There are some timing requirements the user must observe when periodically powering-up the transmitter.

The on-period is determined by the start-up procedure and requires the user to leave the transmitter on for 8-12 mSec. After this time the transmitter is stable and ready to transmit valid data.

The off-period is determined by the discharge rate of the internal bypass capacitors. The capacitors must fully discharge to ensure that subsequent power-ups will reliably restart the microprocessor. This minimum time should be no less than 1 mSec. If the transmitter is not reliably starting after power-up, this time should be increased.

CTS OUTPUT

The **C**lear-**T**o-**S**end output is used to indicate to the user's circuitry when the transmitter is ready to accept data. This pin can be monitored to allow transmission to begin immediately upon the transmitter's synthesizer locking on frequency.

In a typical application, a micro-controller will raise the PDN line high (powering-up the transmitter) and begin to monitor the CTS line. When the CTS line goes high, the micro-controller would start sending data.

In applications where CTS is not used, i.e., an extra I/O pin is not available, the user's circuit should wait a minimum of 50mSec after raising the PDN pin high before transmitting any data.

In applications where remote-control encoders are used, the data is being sent redundantly and there is no need to monitor the CTS pin or to wait a fixed time.

CHANNEL SELECTION

The HP-II transmitter module features eight user-selectable channels. The channel of operation is determined by the state of pins CS0-CS2. Figure 17 shows a channel-selection table based on the pins' states. The on-board microprocessor performs all PLL loading functions. This frees the user from complex programming requirements and allows for manual channel selection via switches in product designs where a microprocessor is not used.

CS2	CS1	CS0	Channel	Frequency
0	0	0	0	903.37
0	0	1	1	906.37
0	1	0	2	907.87
0	1	1	3	909.37
1	0	0	4	912.37
1	0	1	5	915.37
1	1	0	6	919.87
1	1	1	7	921.37

Figure 17: Channel Selection Table

INPUTTING DIGITAL DATA

The data input pin may be directly connected to virtually any digital peripheral including microcontrollers, encoders, and UARTs. The data input has been optimized for NRZ serial data that transitions from 0V to 3V (or has a 3V Pk amplitude).

The equivalent circuit of the data input pin is shown in figure 11. An 8.2K series resistor with a 3300pF shunt capacitor forms a low-pass filter and serves to limit the risetimes of the incoming square waves. The designer must be careful to ensure that this pin is driven with a low impedance to prevent changing the cutoff frequency of the low-pass filter.

If the data input pin is driven from a 5V source (i.e., a microcontroller's UART that is powered by 5V), the designer should put a 2.2K resistor in series with the data pin.

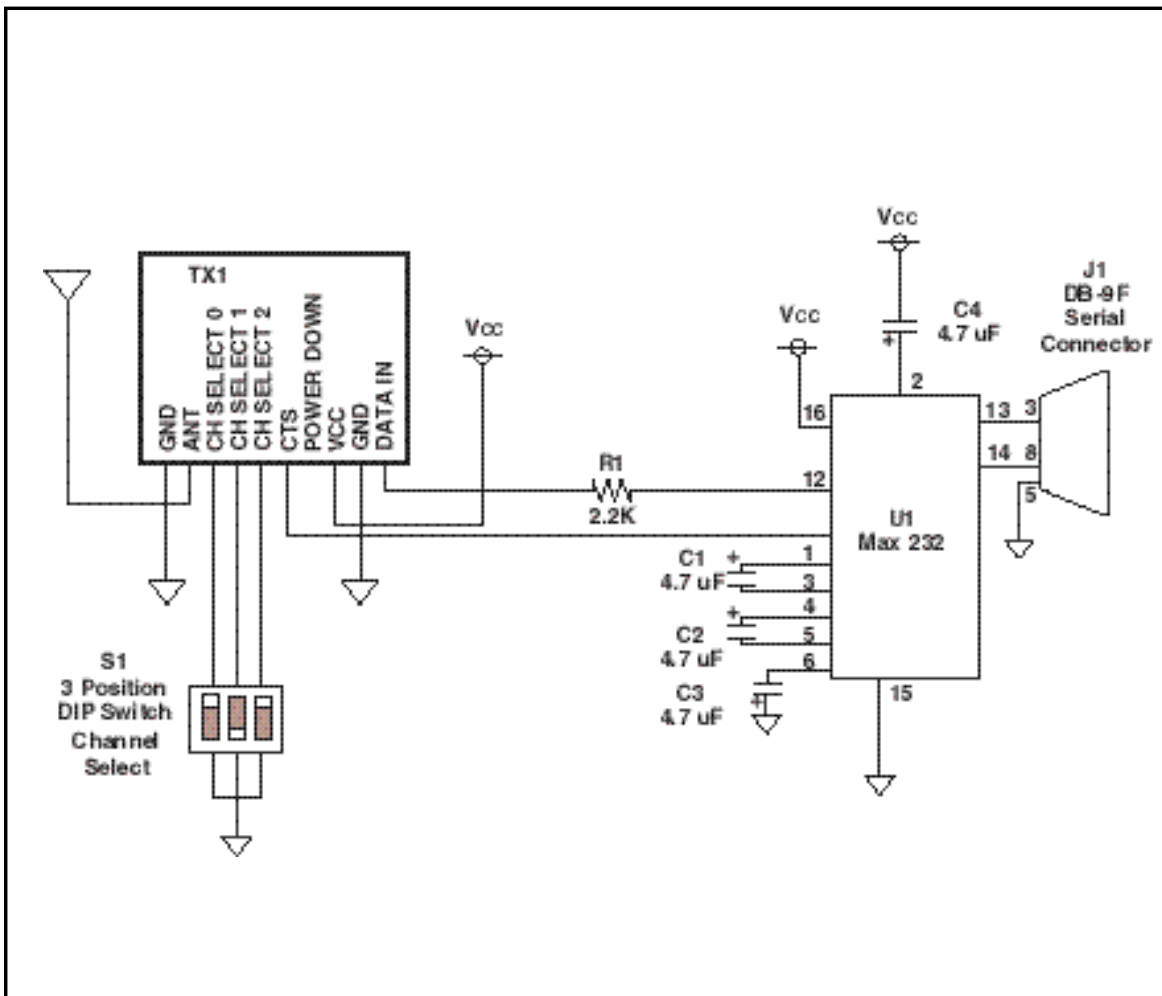


Figure 18: Typical Application: RS-232 Interface

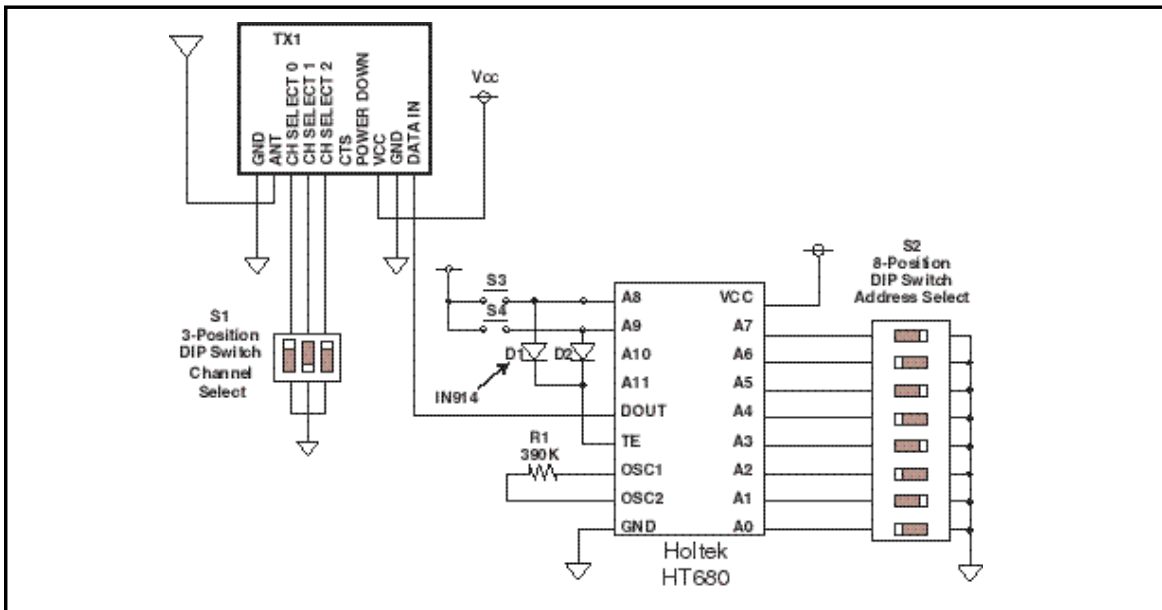


Figure 19: Typical Application: Remote-Control Transmitter

INPUTTING ANALOG SIGNALS

HP Series-II modules are capable of transmitting a wide range of analog signals with minimal distortion. The Typical Performance Graphs on p. 3 of this manual illustrate the modulation linearity for a variety of simple waveforms. The module is equally adept at transmitting complex waveforms such as voice. Analog signals ranging from 50 Hz to 25 KHz may be applied to the data input pin. The voltage swing on the data input pin should be between ground and 3 volts. This voltage directly modulates the VCXO in order to obtain an FM output.

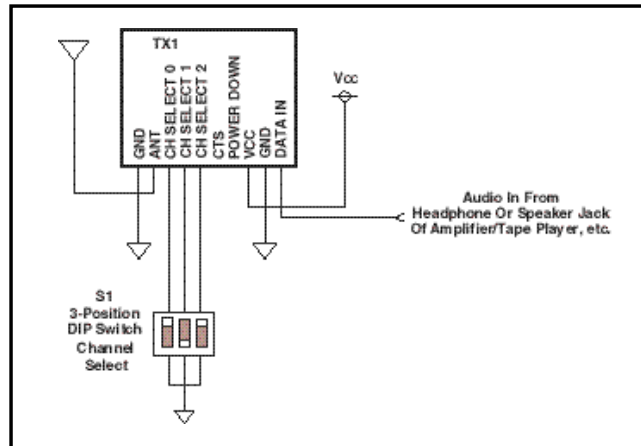


Figure 20: Typical Application: Voice Transmitter

The illustration above shows the simplicity of transmitting audio with the HP Series-II. In applications where the highest audio quality is required an external compandor such as a Phillips SA576 may be employed to increase dynamic range and reduce noise.

PROXIMITY OPERATION

Multiple transmitters may be active on separate channels so long as an adjacent channel's signal does not enter the receiver at a level exceeding the rejection capability of the receiver. If modules are combined to form a transceiver they should be operated in half-duplex, meaning that only the transmitter or receiver is active at any time.

ANTENNA CONSIDERATIONS

The range of the RF link is widely variable and depends upon the type of antenna employed and the operating environment. Proper design and matching of an antenna is a complex task requiring sophisticated test equipment and a strong background in principles of RF propagation. While adequate antenna performance can often be obtained by trial and error methods, you may also want to consider utilizing a premade antenna from Linx. Our low-cost antenna line is designed to ensure maximum performance and Part 15 compliance.

It is usually best to utilize a basic quarter-wave whip for your initial concept evaluation. This can easily be made from a piece of wire as shown on the next page. Once the prototype product is operating satisfactorily, a production antenna should be selected to meet the cost, size and cosmetic requirements of the product. It is important to recognize that the antenna plays a significant role in determining the performance and legality of your end product. In order to gain a better understanding of the considerations involved in the design and selection of antennas please review Linx applications note #00500 "Antennas: Design, Application, Performance".

The following notes should help in achieving optimum antenna performance:

1. Proximity to objects such as a user's hand or body, or metal objects will cause an antenna to detune. For this reason the antenna shaft and tip should be positioned as far away from such objects as possible.
2. Optimum performance will be obtained from a 1/4- or 1/2-wave straight whip mounted at a right angle to the ground-plane. In many cases this isn't desirable for practical or ergonomic reasons; thus, an alternative antenna style such as a helical, loop, patch, or base-loaded whip may be utilized.
3. It is always a good practice to include a T-attenuation pad as described under "Board Layout Considerations". This allows your product's output power to be adjusted for certification purposes without change or compromise to the antenna.
4. If an internal antenna is to be used, keep it away from other metal components, particularly large items like transformers, batteries, and PCB tracks and ground-planes. In many cases, the space around the antenna is as important as the antenna itself.
5. In many antenna designs, particularly 1/4-wave whips, the ground-plane acts as a counterpoise, forming, in essence, a 1/2-wave dipole. For this reason adequate ground-plane area is essential. As a general rule the ground-plane to be used as counterpoise should have a surface area the overall length of the 1/4-wave radiating element.
6. Remove the antenna as far as possible from potential internal interference sources. Switching power supplies, oscillators, even relays can also be significant sources of potential interference. The single best weapon against such problems is attention to placement and layout. Filter the module's power supply with a high-frequency bypass capacitor. Place adequate ground-plane under all potential sources of noise. Shield noisy board areas whenever practical.
7. In some applications it is advantageous to place the transmitter and its antenna away from the main equipment. This avoids interference problems and allows the antenna to be oriented for optimum RF performance. Always use 50 coax such as RG-174 for the remote feed.

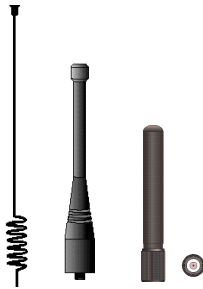
COMMON ANTENNA STYLES

From a coat hanger to a tuned Yagi, there are literally hundreds of antenna styles and variations that can be employed. Following is a brief discussion of the three styles most commonly utilized in compact RF designs. The selection chart broadly categorizes key areas of antenna performance. In reviewing this section it is important to recognize that each antenna style will produce widely varying results based on the specific design execution and optimization. Additional antenna information can be found in Linx application notes #00500, #00100, #00126 and #00140.

HP Antenna Selection Chart

PARAMETER	LOOP	HELICAL	WHIP
Ultimate performance	●	●●	●●●
Ease of design setup	●	●●	●●●
Size	●●	●●●	●
Immunity to proximity effects	●●●	●●	●
HP Range (open ground to similar antenna)	400 ft.	600 ft.	1,000+ ft.
	●=FAIR	●●=GOOD	●●●=EXCELLENT

Whip Style



1/4 wave wire lengths for HP-II frequencies:
902-928MHz =3.06"

A whip-style antenna provides exceptional performance and is easy to integrate. A low-cost whip is generally made of a wire or rod while more expensive whip designs are encapsulated in rubber or plastic to improve appearance and minimize the potential for damage to the antenna element. A whip is often combined with a helical winding to reduce the overall length. This technique is commonly referred to as "base loading". The wavelength of the frequency to be received or transmitted determines an antenna's length. Since a full-wave antenna is quite long, a partial wavelength antenna such as a 1/2- or 1/4-wave is generally used. For testing, or even production, a whip can be easily made from a piece of solid conductor wire cut to the appropriate length. Length for a half-wave is easily determined using the following formula. The resultant length may be divided in half for a quarter-wave.

$$L = \frac{234}{F_{MHz}}$$

Where:
L=length in feet of half-wave length
F=operating frequency in megahertz

Helical Style



A helical is a wire coil usually wound from steel, copper or brass. This antenna is very efficient given its small size. The helical is an excellent choice for products requiring good range-performance and a concealed internal antenna element. Care must be exercised in placement, however, as a helical detunes badly when located in proximity with other conductive objects. Because a helical has a high "Q" factor its bandwidth is very narrow and inter-coil spacing has a pronounced effect on antenna performance. For this reason, it is usually best to utilize a premade helical which has been professionally optimized to achieve maximum performance.

Loop Style



A loop or track-style antenna is usually printed directly on the PCB, making it the most cost-effective of antenna styles. There are many different styles and shapes of loops which can be utilized, including spirals and rectangles. A loop has excellent immunity to proximity detuning (i.e., a user's body) and is easily concealed inside products which have a plastic case. Despite these advantages, a loop is difficult to match and tune without expensive RF test equipment. An improperly designed loop will have a very high SWR and may induce harmonics. For this reason a helical or whip style is usually a better choice for applications requiring maximum range-performance.

LEGAL CONSIDERATIONS

NOTE: HP Series-II Modules are designed as component devices which require external components to function. The modules are intended to allow for full Part 15 compliance; however, they are not approved by the FCC or any other agency worldwide. The purchaser understands that approvals may be required prior to the sale or operation of the device, and agrees to utilize the component in keeping with all laws governing its operation in the country of operation.

When working with RF, a clear distinction must be made between what is technically possible and what is legally acceptable in the country where operation is intended. Many manufacturers have avoided incorporating RF into their products as a result of uncertainty and even fear of the approval and certification process. Here at Linx our desire is not only to expedite the design process, but also to assist you in achieving a clear idea of what is involved in obtaining the approvals necessary to legally market your completed product.

In the United States the approval process is actually quite straightforward. The regulations governing RF devices and the enforcement of them are the responsibility of the Federal Communications Commission. The regulations are contained in the Code of Federal Regulations (CFR), Title 47. Title 47 is made up of numerous volumes; however, all regulations applicable to this module are contained in volume 0-19. It is strongly recommended that a copy be obtained from the Government Printing Office in Washington, or from your local government book store. Excerpts of applicable sections are included with Linx evaluation kits or may be obtained from the Linx Technologies web site (www.linxtechnologies.com). In brief, these rules require that any device which intentionally radiates RF energy be approved, that is, tested, for compliance and issued a unique identification number. This is a relatively painless process. Linx offers full EMC pre-compliance testing in our HP/Emco-equipped test center. Final compliance testing is then performed by one of the many independent testing laboratories across the country. Many labs can also provide other certifications the product may require at the same time, such as UL, CLASS A/B, etc. Once your completed product has passed, you will be issued an ID number which is then clearly placed on each product manufactured.

Questions regarding interpretations of the Part 2 and Part 15 rules or measurement procedures used to test intentional radiators, such as the HP-II modules, for compliance with the Part 15 technical standards, should be addressed to:

Federal Communications Commission
Equipment Authorization Division
Customer Service Branch, MS 1300F2
7435 Oakland Mills Road
Columbia, MD 21046
Tel:(301) 725-1585 / Fax:(301) 344-2050 E-Mail:labinfo@fcc.gov

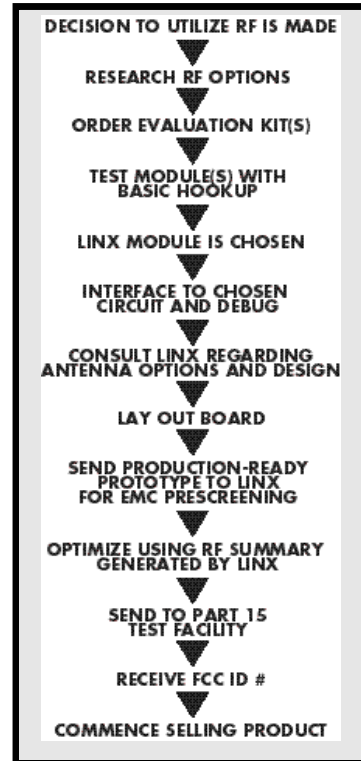
International approvals are slightly more complex, although many modules are designed to allow all international standards to be met. If you are considering the export of your product abroad, you should contact Linx Technologies to determine the specific suitability of the module to your application.

All Linx modules are designed with the approval process in mind and thus much of the frustration that is typically experienced with a discrete design is eliminated. Approval is still dependent on many factors such as the choice of antennas, correct use of the frequency selected, and physical packaging. While some extra cost and design effort are required to address these issues, the additional usefulness and profitability added to a product by RF makes the effort more than worthwhile.

SURVIVING AN RF IMPLEMENTATION

Adding an RF stage brings an exciting new dimension to any product. It also means that additional effort and commitment will be needed to bring the product successfully to market. By utilizing premade RF modules, such as the HP Series-II, the design and approval process will be greatly simplified. It is important, however, to have an objective view of the steps necessary to insure a successful RF integration. Since the capabilities of each customer vary widely it is difficult to recommend one particular design path, but most projects follow steps similar to those shown at the right.

In reviewing this sample design path you may notice that Linx offers a variety of services, such as antenna design, and FCC prequalification, that are unusual for a high-volume component manufacturer. These services, along with an exceptional level of technical support, are offered because we recognize that RF is a complex science requiring the highest caliber of products and support. "Wireless Made Simple" is more than just a motto, it's our commitment. By choosing Linx as your RF partner and taking advantage of the resources we offer, you will not only survive implementing RF, but you may even find the process enjoyable.



TYPICAL STEPS FOR IMPLEMENTING RF

HELPFUL APPLICATION NOTES FROM LINX

It is not the intention of this manual to address in depth many of the issues that should be considered to ensure that the modules function correctly and deliver the maximum possible performance. As you proceed with your design you may wish to obtain one or more of the following application notes, which address in depth key areas of RF design and application of Linx products.

NOTE #	LINX APPLICATION NOTE TITLE
00500	Antennas: Design, Application, Performance
00130	Modulation techniques for low-cost RF data links
00126	Considerations for operation in the 902 Mhz to 928 Mhz band
00100	RF 101: Information for the RF challenged
00140	The FCC Road: Part 15 from concept to approval
00150	Use and design of T-Attenuation Pads
00110	Understanding the performance specifications of receivers
00160	Considerations for sending data with the HP Series-II



U.S. CORPORATE HEADQUARTERS:

LINX TECHNOLOGIES, INC.

575 S.E. ASHLEY PLACE
GRANTS PASS, OR 97526

Phone: (541) 471-6256

FAX: (541) 471-6251

<http://www.linxtechnologies.com>

Disclaimer

Linx Technologies is continually striving to improve the quality and function of its products; for this reason, we reserve the right to make changes without notice. The information contained in this Data Sheet is believed to be accurate as of the time of publication. Specifications are based on representative lot samples. Values may vary from lot to lot and are not guaranteed. Linx Technologies makes no guarantee, warranty, or representation regarding the suitability of any product for use in a specific application. None of these devices is intended for use in applications of a critical nature where the safety of life or property is at risk. The user assumes full liability for the use of product in such applications. Under no conditions will Linx Technologies be responsible for losses arising from the use or failure of the device in any application, other than the repair, replacement, or refund limited to the original product purchase price. Some devices described in this publication are patented. Under no circumstances shall any user be conveyed any license or right to the use or ownership of these patents.

© 1999 by Linx Technologies, Inc. The stylized Linx logo, Linx, and "Wireless made Simple" are the trademarks of Linx Technologies, Inc.
Printed in U.S.A.