



TSH512

Hi-fi stereo/mono infrared transmitter and stereo sub-carrier generator

Features

- Supply voltage: 2.3 to 5.5 V
- Carrier frequency range: 0.4 to 11 MHz
- High versatility: I/O pins for each section
- Two FM transmitters for stereo
- Sinusoidal carriers for high spectral purity
- Micro- or line-level preamplifiers with ALC
- VOX function to save on battery power
- Transmitter TX2 standby for mono operation

Applications

- Infrared hi-fi stereo transmitters
- Infrared headsets
- Stereo sub-carriers for video transmitters
- Voice-operated wireless webcams
- FM IF transmit systems

Description

The TSH512 is a 0.4- to 11-MHz dual FM transmitter. Access pins to each section give high versatility and allow for several different applications: stereo headphone, multimedia headset, audio sub-carrier generator.

The TSH512 integrates in a single chip low-noise audio preamplifiers with ALC (automatic level control), frequency-modulated oscillators, and linear output buffers to drive the external transistors. The sinusoidal carriers facilitate the filtering and allow high performance audio transmission.

The VOX (voice operated transmit) circuitry disables the output buffer when there is no audio signal to save battery power. For MONO applications, the STANDBY pin enables one transmitter only, reducing the supply current.

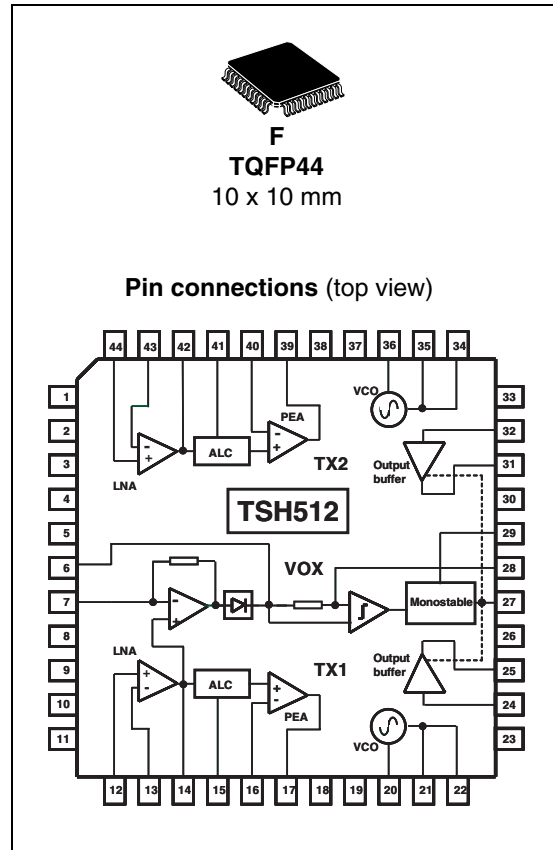

The TSH512 forms a chipset with the dual receiver TSH511.

Contents

1	Absolute maximum ratings and operating conditions	3
2	Device diagrams and schematics	4
3	Electrical characteristics	7
3.1	Supply section	10
3.2	Audio section	10
3.3	RF section	13
4	Application information	14
4.1	Infrared stereo transmitter application (stereo headphones)	14
4.2	Sub-carrier generator application: voice-operated wireless camera	16
4.3	Multimedia application	16
4.3.1	Headset side	16
4.3.2	Computer side	17
5	General description	18
5.1	LNA section: low noise amplifier	18
5.2	Electret condenser microphone source	19
5.3	MIC-BIAS section: microphone bias voltage	20
5.4	ALC section: automatic level control	21
5.5	VOX description: voice operated transmit	21
5.6	PEA section: pre-emphasis	24
5.7	VCO section: voltage-controlled oscillator	25
5.8	Output buffer section	26
5.9	SBY pin: standby for mono operation	26
6	Package information	27
6.1	TQFP44 package information	28
7	Ordering information	29
8	Revision history	30

1 Absolute maximum ratings and operating conditions

Table 1. Absolute maximum ratings

Symbol	Parameter	Value	Unit
V_{CC}	Supply voltage ⁽¹⁾	7	V
T_{oper}	Operating free air temperature range	-40 to +85	°C
T_{stg}	Storage temperature	-65 to +150	°C
T_j	Maximum junction temperature	150	°C
R_{thjc}	Thermal resistance junction to case	14	°C/W
R_{thja}	Thermal resistance junction to ambient area	45	°C/W
Latch-up	Class ⁽²⁾	A	
ESD sensitive device: handling precautions required			
ESD except pins 20 and 36	HBM: human body model ⁽³⁾	2	kV
	CDM: charged device model ⁽⁴⁾	1	
	MM: machine model ⁽⁵⁾	0.2	

1. All voltage values, except differential voltage, are with respect to network ground terminal.
2. Corporate ST Microelectronics procedure number 0018695.
3. Human body model: a 100 pF capacitor is charged to the specified voltage, then discharged through a 1.5 kΩ resistor between two pins of the device. This is done for all couples of connected pin combinations while the other pins are floating.
4. Charged device model: all pins and the package are charged together to the specified voltage and then discharged directly to the ground through only one pin. This is done for all pins.
5. Machine model: a 200 pF capacitor is charged to the specified voltage, then discharged directly between two pins of the device with no external series resistor (internal resistor < 5 Ω). This is done for all couples of connected pin combinations while the other pins are floating.

Table 2. Operating conditions

Symbol	Parameter	Value	Unit
V_{CC}	Supply voltage	2.3 to 5.5	V
f_{audio}	Audio frequency range	20 to 20,000	Hz
$f_{carrier}$	Carrier frequency range	0.4 to 11	MHz

2 Device diagrams and schematics

This section contains a detailed block diagram of the TSH512 (Figure 1), with an accompanying pin description (Table 3 on page 5), as well as the schematics of a typical application (Figure 2 on page 6).

Figure 1. Block diagram

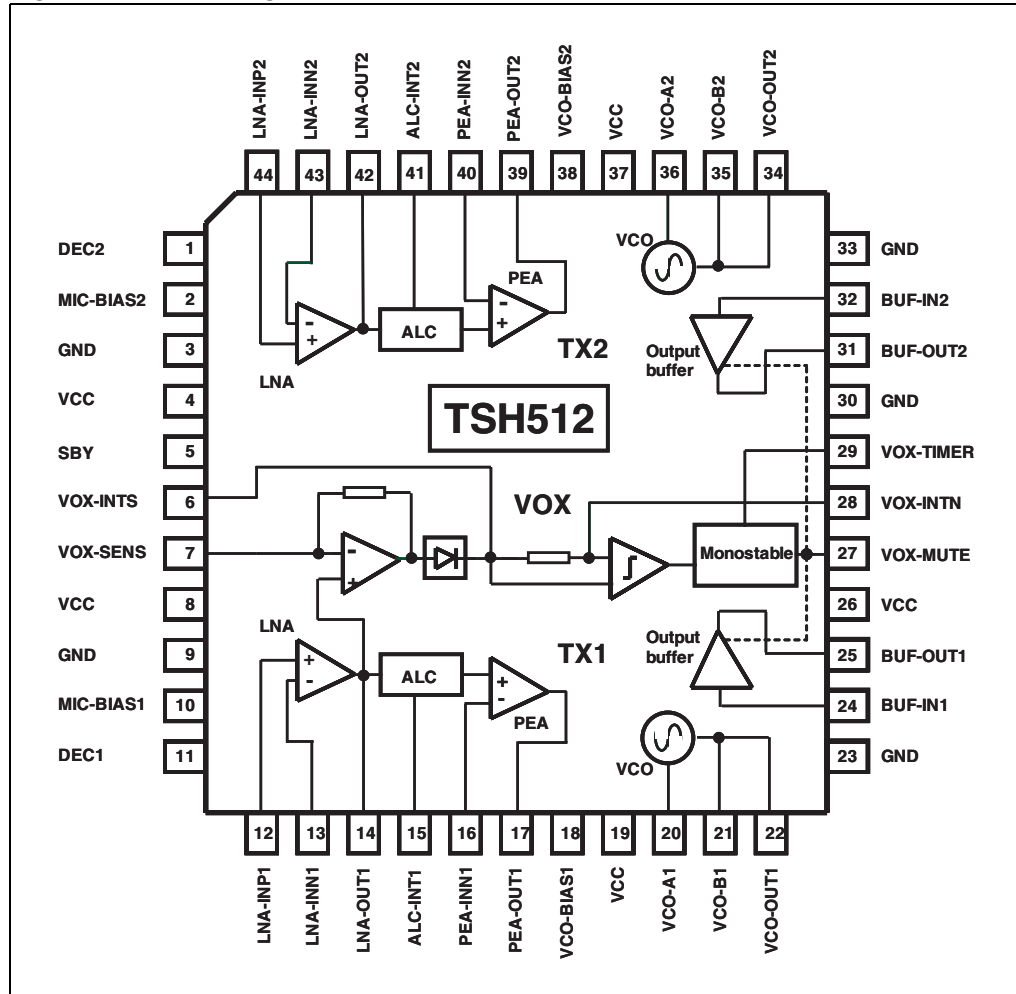

Table 3. Pin descriptions

Pin	Pin name	Related to	Direction ⁽¹⁾	Pin description
1	DEC2	TX2	-	Decoupling capacitor for internal voltage reference
2	MIC-BIAS2	TX2	O	Microphone bias
3	GND	-	-	Ground
4	VCC	-	-	Supply voltage
5	SBY	TX1 & TX2	I	Standby control (input pin)
6	VOX-INTS	TX1 & TX2	-	Time constant terminal for audio signal integrator in VOX
7	VOX-SENS	TX1 & TX2	-	Gain adjustment for VOX input sensitivity
8	VCC	-	-	Supply voltage
9	GND	-	-	Ground
10	MIC-BIAS1	TX1	O	Microphone bias
11	DEC1	TX1	-	Decoupling capacitor for internal voltage reference
12	LNA-INP1	TX1	I	LNA positive input
13	LNA-INN1	TX1	I	LNA negative input
14	LNA-OUT1	TX1	O	LNA output
15	ALC-INT1	TX1	-	Time constant terminal for integrator in ALC
16	PEA-INN1	TX1	I	Pre-emphasis amplifier negative input
17	PEA-OUT1	TX1	O	Pre-emphasis amplifier output
18	VCO-BIAS1	TX1	O	Bias for external VCO components
19	VCC	-	-	Supply voltage
20	VCO-A1	TX1	-	Oscillator component connection
21	VCO-B1	TX1	-	Oscillator component connection
22	VCO-OUT1	TX1	O	VCO output
23	GND	-	-	Ground
24	BUF-IN1	TX1	I	Input to the output buffer
25	BUF-OUT1	TX1	O	Output of the output buffer
26	VCC	-	-	Supply voltage
27	VOX-MUTE	TX1 & TX2	O	Mute control (output pin) in VOX
28	VOX-INTN	TX1 & TX2	-	Time constant terminal for noise integrator in VOX
29	VOX-TIMER	TX1 & TX2	-	Rise time for timer in VOX
30	GND	-	-	Ground
31	BUF-OUT2	TX2	O	Output of the output buffer
32	BUF-IN2	TX2	I	Input to the output buffer
33	GND	-	-	Ground
34	VCO-OUT2	TX2	O	VCO output
35	VCO-B2	TX2	-	Oscillator component connection

Table 3. Pin descriptions (continued)

Pin	Pin name	Related to	Direction ⁽¹⁾	Pin description
36	VCO-A2	TX2	-	Oscillator component connection
37	VCC	-	-	Supply voltage
38	VCO-BIAS2	TX2	O	Bias for external VCO components
39	PEA-OUT2	TX2	O	Pre-emphasis amplifier output
40	PEA-INN2	TX2	I	Pre-emphasis amplifier negative input
41	ALC-INT2	TX2	-	Time constant terminal for internal peak detector in ALC
42	LNA-OUT2	TX2	O	LNA output
43	LNA-INN2	TX2	I	LNA negative input
44	LNA-INP2	TX2	I	LNA positive input

1. Pin directions: I = input pin, O = output pin, - = pin to connect to supply or decoupling capacitors or external components.

Figure 2. Typical application schematics for stereo infrared transmitter

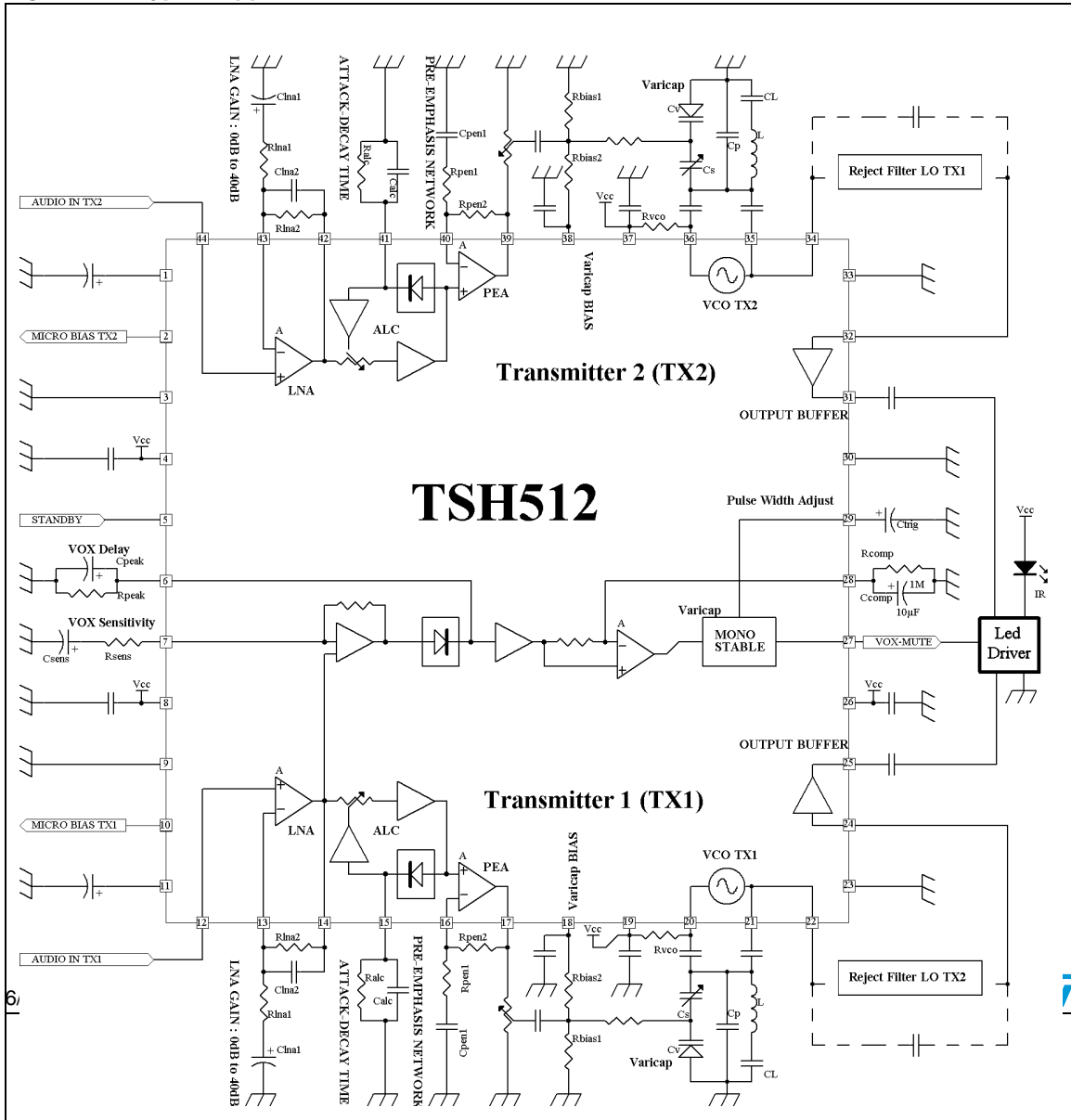

3 Electrical characteristics

Table 4. Electrical characteristics for $V_{CC} = 2.7\text{ V}$, $T_{amb} = 25^\circ\text{ C}$, $f_{audio} = 1\text{ kHz}$, $f_{carrier} = 2.8\text{ MHz}$ (unless otherwise specified) ⁽¹⁾

Symbol	Parameter	Test conditions	Min.	Typ.	Max.	Unit
Overall circuit						
I_{CC_TOT}	Current consumption TX1 and TX2 are on	TX1 on, TX2 on, MIC-BIAS1 and MIC-BIAS2 not used: VOX-MUTE=1 output buffers on VOX-MUTE=0, output buffers off		16 11	18.6 12.8	mA
		$-40^\circ\text{ C} < T_{amb} < +85^\circ\text{ C}$ VOX-MUTE=1 output buffers on VOX-MUTE=0, output buffers off			19.6 13.8	
I_{CC_SBY}	Current consumption with TX2 in standby: SBY (pin5) active	TX1 on, TX2 off, MIC-BIAS1 and MIC-BIAS2 not used: VOX-MUTE=1, output buffers on VOX-MUTE=0, output buffers off		10 7	11.5 8	mA
		$-40^\circ\text{ C} < T_{amb} < +85^\circ\text{ C}$ VOX-MUTE=1, output buffers on VOX-MUTE=0, output buffers off			12.1 8.6	
LNA sections (for TX1 and TX2)						
GBP_{LNA}	Gain bandwidth product	No external load		7		MHz
R_{inLNA}	Input resistance on positive input: (LNA-INP1 pin 12 or LNA-INP2 pin 44)			30		k Ω
THD_{LNA}	Total harmonic distortion	$G_{LNA} = 0\text{ dB}$, $V_{outLNA} = 700\text{ mV}_{PP}$		0.01	0.05	%
		$-40^\circ\text{ C} < T_{amb} < +85^\circ\text{ C}$			0.05	
E_n	Equivalent input noise voltage	$G_{LNA} = 40\text{ dB}$, at $f = 1\text{ kHz}$ $R_S = 390\ \Omega$, $R_{feedback} = 39\text{ k}\Omega$		6		nV/ $\sqrt{\text{Hz}}$
Automatic level control (ALC) section						
G_{ALC}	Voltage gain			20		dB
V_{ALC_OUT}	Regulated output level (at positive input of the PEA amplifier)		600	710	800	mVpp
		$-40^\circ\text{ C} < T_{amb} < +85^\circ\text{ C}$	597		803	
Pre-emphasis amplifier (PEA) section						
GBP_{PEA}	Gain bandwidth product (PEA-OUT1 pin 17 or PEA-OUT2 pin 39)	No load		9		MHz
$V_{Opp-PEA}$	Output voltage	$R_L = 22\text{ k}\Omega$		550		mVpp

Table 4. Electrical characteristics for $V_{CC} = 2.7\text{ V}$, $T_{amb} = 25^\circ\text{ C}$, $f_{audio} = 1\text{ kHz}$, $f_{carrier} = 2.8\text{ MHz}$ (unless otherwise specified) (continued) ⁽¹⁾

Symbol	Parameter	Test conditions	Min.	Typ.	Max.	Unit
Audio LNA+ALC+PEA sections						
THD _{ALC}	Total harmonic distortion in linear region on PEA-OUT1 pin17 or PEA-OUT2 pin 39	$G_{LNA} = 0\text{ dB}$, $f = 1\text{ kHz}$ $(V_{in})_{ALC} < 25\text{ mV}_{rms}$ (-30 dBu) $R_L = 22\text{ k}\Omega$ tied to GND		0.05	0.15	%
		$-40^\circ\text{ C} < T_{amb} < +85^\circ\text{ C}$			0.25	
THD _{AGC}	Total harmonic distortion in compression region	$(V_{in})_{ALC} = 36\text{ mV}_{rms}$ (-27 dBu) $(V_{in})_{ALC} = 100\text{ mV}_{rms}$ (-18 dBu) $R_L = 22\text{ k}\Omega$ tied to GND		1.3 3	1.7 4	%
		$-40^\circ\text{ C} < T_{amb} < +85^\circ\text{ C}$				
		$(V_{in})_{ALC} = 36\text{ mV}_{rms}$ (-27 dBu) $(V_{in})_{ALC} = 100\text{ mV}_{rms}$ (-18 dBu)			2.5 5.3	
ϕM_{PEA}	Phase margin at PEA-OUT1 pin 17 or PEA-OUT2 pin 39	$R_L = 22\text{ k}\Omega$ LNA and PEA at unity gain $V_{in} = 40\text{ mV}$		70		$^\circ$
Microphone biasing section						
$V_{MIC-BIAS}$	Microphone biasing voltage (Section 5.3 on page 20)	$I_{MIC-BIAS} = 2.5\text{ mA}$	2.15	2.25	2.35	V
		$-40^\circ\text{ C} < T_{amb} < +85^\circ\text{ C}$	2.14		2.36	
$\Delta V_{MIC-BIAS}$	$V_{MIC-BIAS}$ temperature coefficient	Over temp. range: [0, 70 $^\circ\text{ C}$] [-40, 85 $^\circ\text{ C}$] $I_{MIC-BIAS} = 2.5\text{ mA}$		260 460		ppm/ $^\circ\text{ C}$
$I_{MIC-BIAS}$	MIC-BIAS current capability	Over V_{CC} range [2.3 V–5.5 V]	2.5			mA
$PSRR_{MIC-BIAS}$	Power supply rejection ratio of MIC-BIAS	At 1 kHz and $V_{ripple} = 25\text{ mV}_{RMS}$		50		dB
$e_{nMIC-BIAS}$	Equivalent input noise of MIC-BIAS	$V_{CC} = 2.7\text{ V}$ $V_{CC} = 5.0\text{ V}$		22 42		nV/ $\sqrt{\text{Hz}}$
Vox operated switch (VOX) section						
$I_{VOX-TIMER}$	Monostable current source (VOX-TIMER pin 29)	$V_{CC} = 2.7\text{ V}$		5		μA
$V_{THVOX-TIMER}$	Threshold voltage of the Monostable (time constant)			1.4		V
V_{MUTE_L}	Low level output voltage (VOX-MUTE pin 27)	$R_L = 2\text{ k}\Omega$			0.2	V
		$-40^\circ\text{ C} < T_{amb} < +85^\circ\text{ C}$			0.2	
V_{MUTE_H}	High level output voltage (VOX-MUTE pin 27)	$R_L = 2\text{ k}\Omega$	$V_{CC}-0.3$			V
		$-40^\circ\text{ C} < T_{amb} < +85^\circ\text{ C}$	$V_{CC}-0.32$			

Table 4. Electrical characteristics for $V_{CC} = 2.7\text{ V}$, $T_{amb} = 25^\circ\text{ C}$, $f_{audio} = 1\text{ kHz}$, $f_{carrier} = 2.8\text{ MHz}$ (unless otherwise specified) (continued) ⁽¹⁾

Symbol	Parameter	Test conditions	Min.	Typ.	Max.	Unit
Standby						
V_{SBY_IL} maximum	Maximum low level input voltage of standby input (SBY pin 5)			$0.1 \times V_{CC}$		V
V_{SBY_IH} minimum	Minimum high level input voltage of standby input (SBY pin 5)			$0.9 \times V_{CC}$		V
VCO section						
$V_{VCO-BIAS}$	VCO-BIAS output voltage (VCO-BIAS1 pin 18 or VCO-BIAS2 pin 38)	With no load	1.43	1.47	1.51	V_{DC}
		$-40^\circ\text{ C} < T_{amb} < +85^\circ\text{ C}$	1.38		1.56	
$I_{VCO-BIAS}$	VCO-BIAS output current capability	$V_{VCO-BIAS} > 1.38\text{ V}$		40		μA
$\delta V_{VCO-BIAS}$	VCO-BIAS voltage drift	$2.3\text{ V} < V_{CC} < 5.5\text{ V}$ [0, 70° C] $V_{CC} = 2.7\text{ V}$ [0, 70° C] $V_{CC} = 5.0\text{ V}$ [-40, 85° C] $V_{CC} = 2.7\text{ V}$ [-40, 85° C] $V_{CC} = 5.0\text{ V}$		8 +265 +356 +265 +356		mV/V ppm/°C ppm/°C ppm/°C ppm/°C
PN_{LO}	Phase noise	At 1 kHz, $L = 120\ \mu\text{H}$ ($Q = 30$) and R_{VCO} not connected		-80		dBc
$SVR_{VCO-BIAS}$	Supply voltage rejection ratio of VCO-BIAS	With no load		43		dB
$Z_{VCO-OUT}$	VCO output impedance (VCO-OUT1 pin 22 or VCO-OUT2 pin 34)			400		Ω
$Z_{L_{VCO-OUT}}$ minimum	Minimum load impedance			1		k Ω
$V_{VCO-OUT}$	VCO output level	$L = 120\ \mu\text{H}$ ($Q = 30$) VCO output connected to output buffer input $R_{VCO} = 100\ \text{k}\Omega$	580	620	660	mVpp
		$-40^\circ\text{ C} < T_{amb} < +85^\circ\text{ C}$	569		671	
Output buffer						
Z_{BUF-IN}	Input impedance (BUF-IN1 pin 24 or BUF-IN2 pin 32)			400		k Ω
G_{OB}	Linear voltage gain			10		dB
$V_{BUF-OUT\ AC}$	Output AC voltage at 1dB compression point	$Z_L = 2\ \text{k}\Omega$		1.3		Vpp
	Output AC voltage (BUF-OUT1 pin 25 or BUF-OUT2 pin 31)	$Z_L = 2\ \text{k}\Omega$ $V_{BUF-IN} = 0.60\ \text{Vpp}$	1.35	1.5	1.7	
		$-40^\circ\text{ C} < T_{amb} < +85^\circ\text{ C}$	1.33		1.72	

Table 4. Electrical characteristics for $V_{CC} = 2.7\text{ V}$, $T_{amb} = 25^\circ\text{ C}$, $f_{audio} = 1\text{ kHz}$, $f_{carrier} = 2.8\text{ MHz}$ (unless otherwise specified) (continued) ⁽¹⁾

Symbol	Parameter	Test conditions	Min.	Typ.	Max.	Unit
$V_{BUF-OUT\ DC}$	Output DC voltage	DC output current = 0.4 mA		1.25		V_{DC}
$H2_{BUF-OUT}$	2nd harmonic level	$V_{BUF-OUT} = 1.2\text{ V}_{pp}$ and $Z_L = 2\text{ k}\Omega$		-40		dBc
$H3_{BUF-OUT}$	3rd harmonic level	$V_{BUF-OUT} = 1.2\text{ V}_{pp}$ and $Z_L = 2\text{ k}\Omega$		-30		dBc

1. Limits over $-40^\circ\text{ C} < T_{amb} < +85^\circ\text{ C}$ range are guaranteed by statistical correlation.

3.1 Supply section

Figure 3. Supply current vs. supply voltage

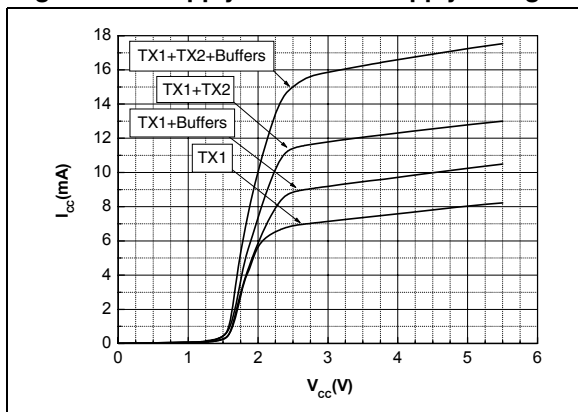

3.2 Audio section

Figure 4. LNA distortion vs. frequency

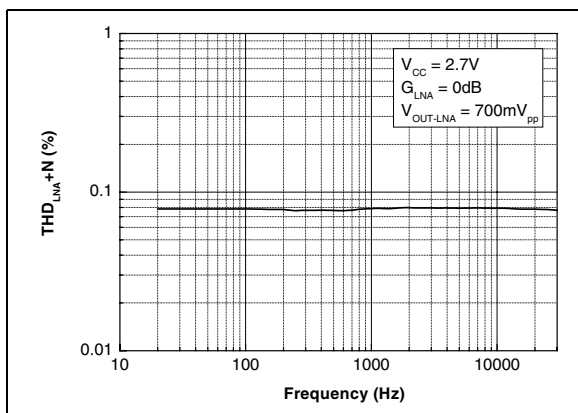

Figure 5. LNA distortion vs. LNA output voltage

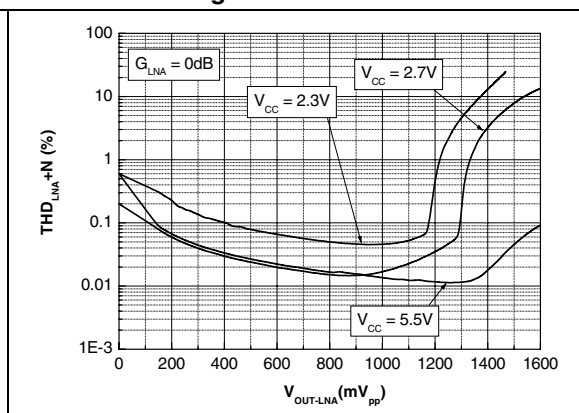

Figure 6. Supply current vs. temperature

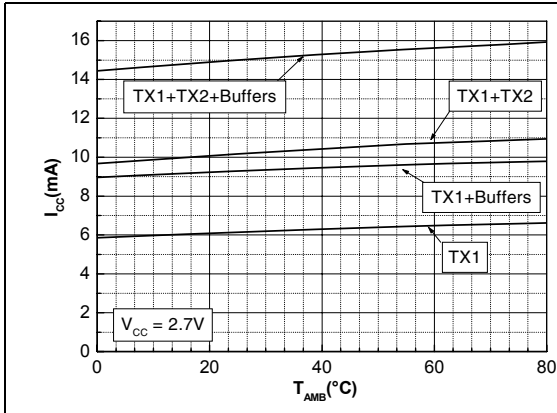

Figure 7. LNA distortion vs. frequency

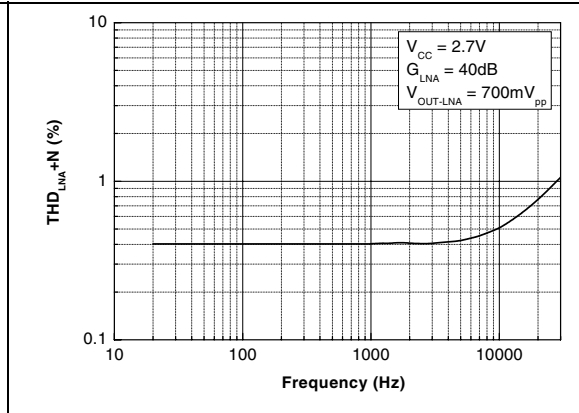

Figure 8. PEA output voltage vs. LNA input voltage

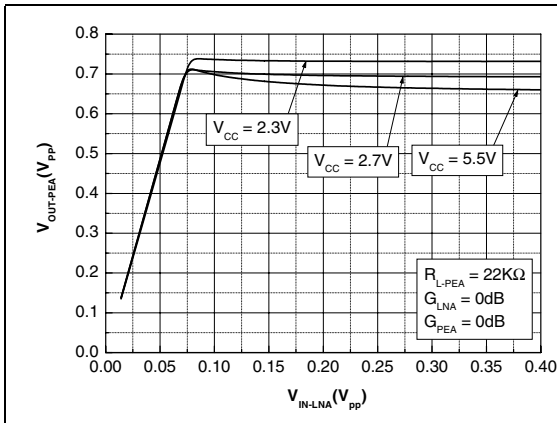

Figure 9. PEA output voltage vs. temperature

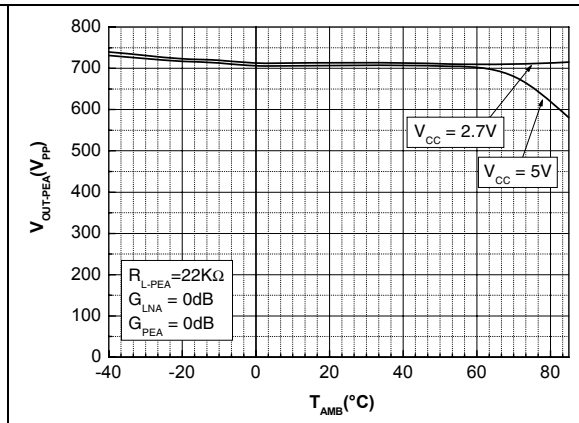

Figure 10. PEA output voltage vs. resistor load

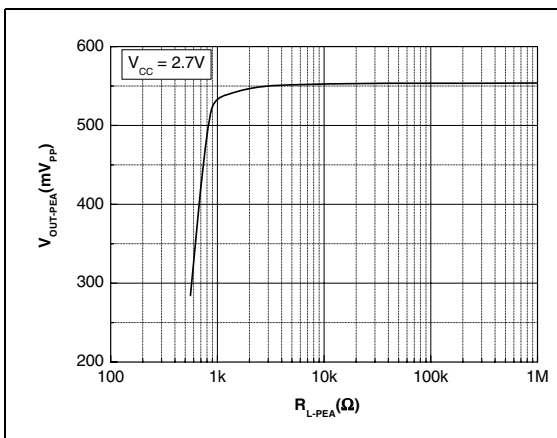

Figure 11. MIC-BIAS output voltage vs. supply voltage

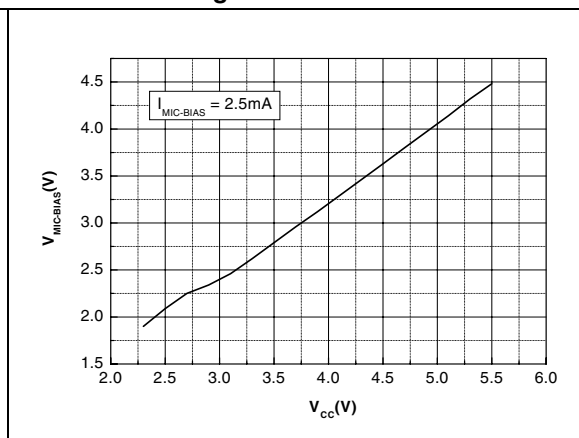

Figure 12. MIC-BIAS voltage vs. MC-BIAS current

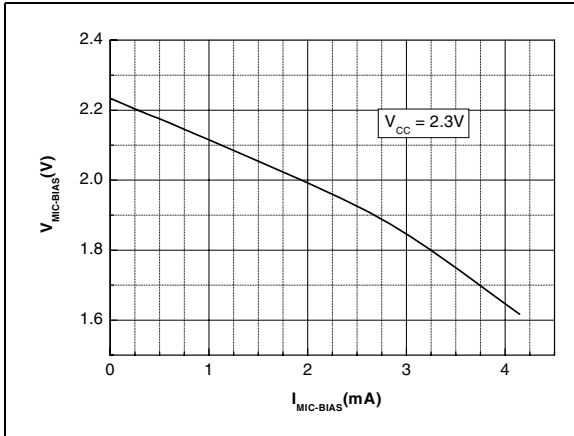

Figure 13. LNA+ALC+PEA distortion vs. input voltage

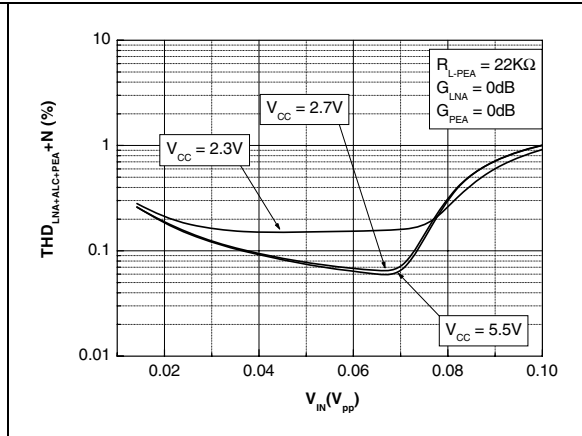

Figure 14. MIC-BIAS output voltage vs. temperature

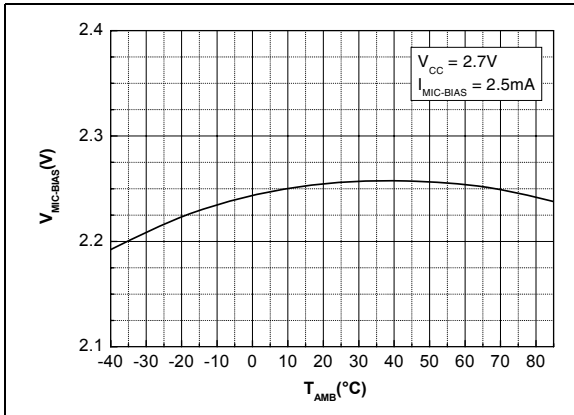
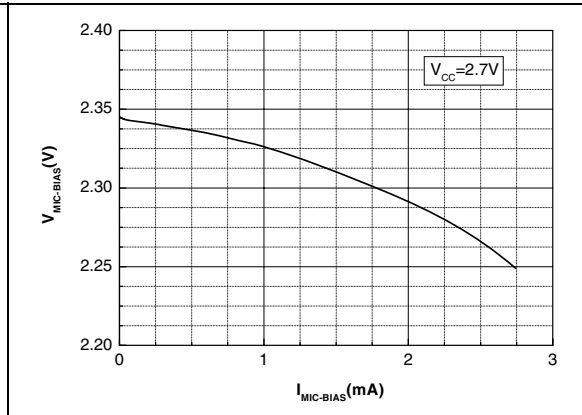

Figure 15. MIC-BIAS voltage vs. MIC-BIAS current



3.3 RF section

Figure 16. VCO output voltage vs. R_{VCO}

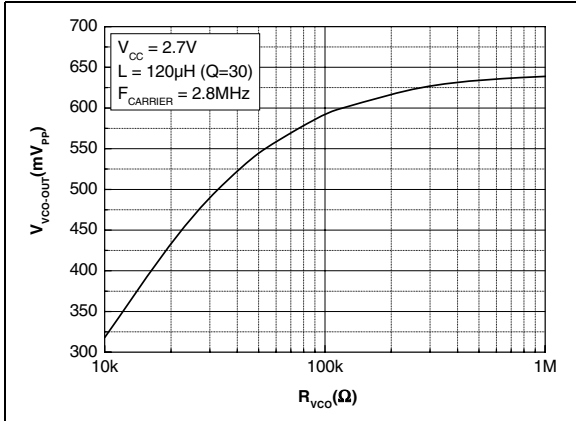

Figure 17. VCO-BIAS voltage vs. VCO-BIAS current

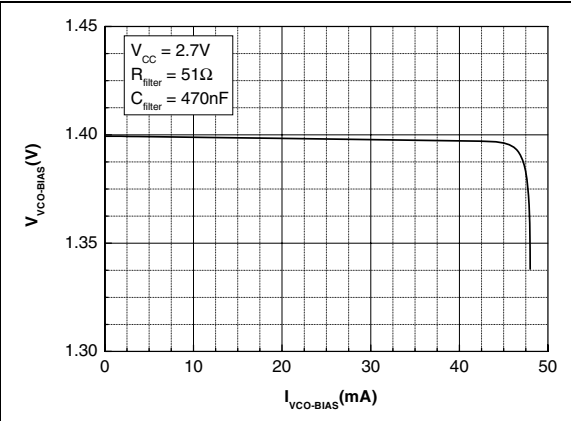

Figure 18. VCO and output buffer spectrum

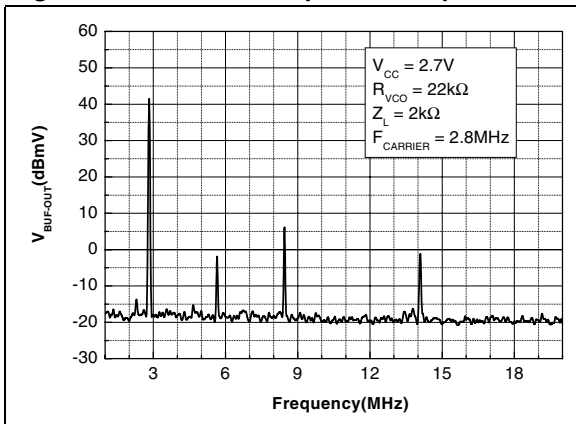

Figure 19. VCO-BIAS voltage vs. temperature

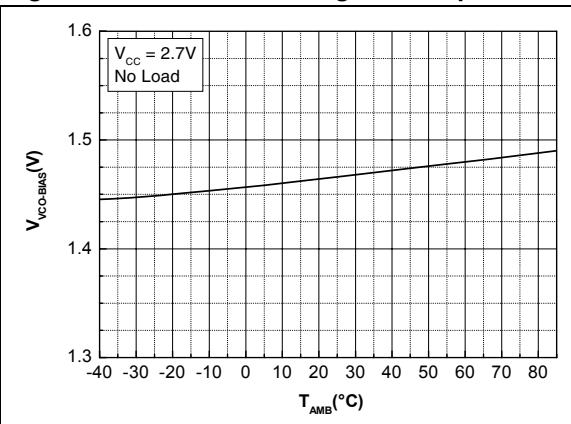
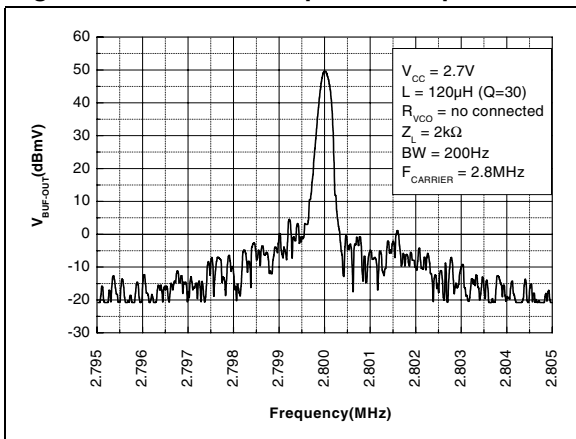

Figure 20. VCO and output buffer spectrum



4 Application information

This section gives application information for some typical applications.

4.1 Infrared stereo transmitter application (stereo headphones)

In this application, shown in [Figure 21](#), the hi-fi stereo audio is amplified and level regulated by ALC. The carrier of each transmitter TX1 or TX2 of the TSH512 is modulated in FM and buffered to drive the LED.

Figure 21. Hi-fi stereo headphone block diagram

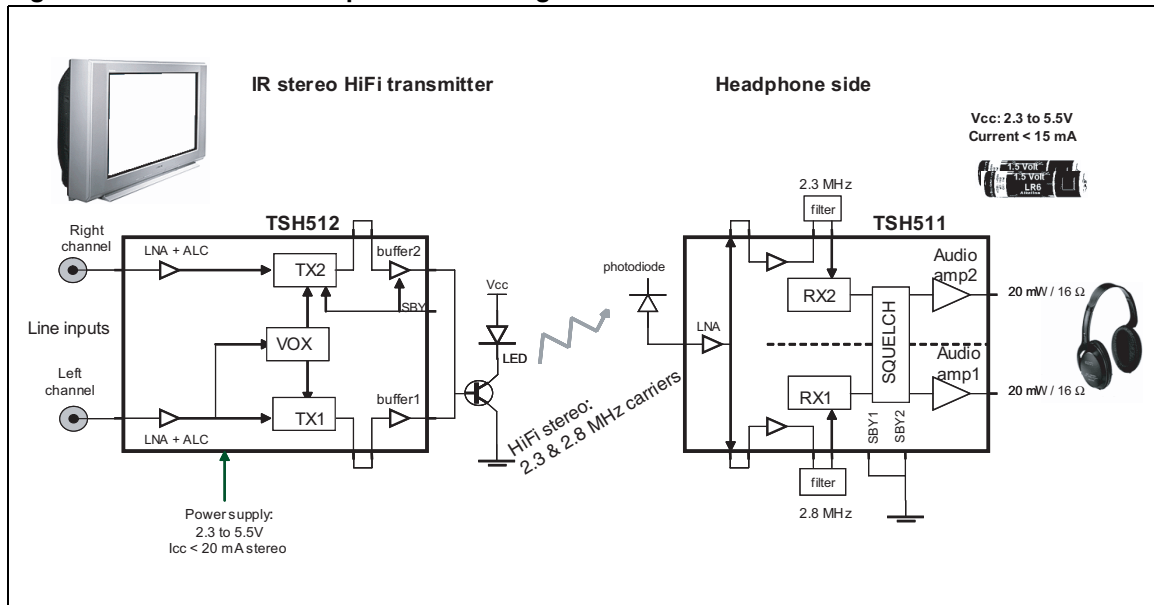

The audio signals are transmitted on the left and the right channels using 2.8- and 2.3-MHz carriers. The VOX activates the TX1 transmitter when the audio signal is present ([Figure 22](#)).

Figure 22. Application diagram

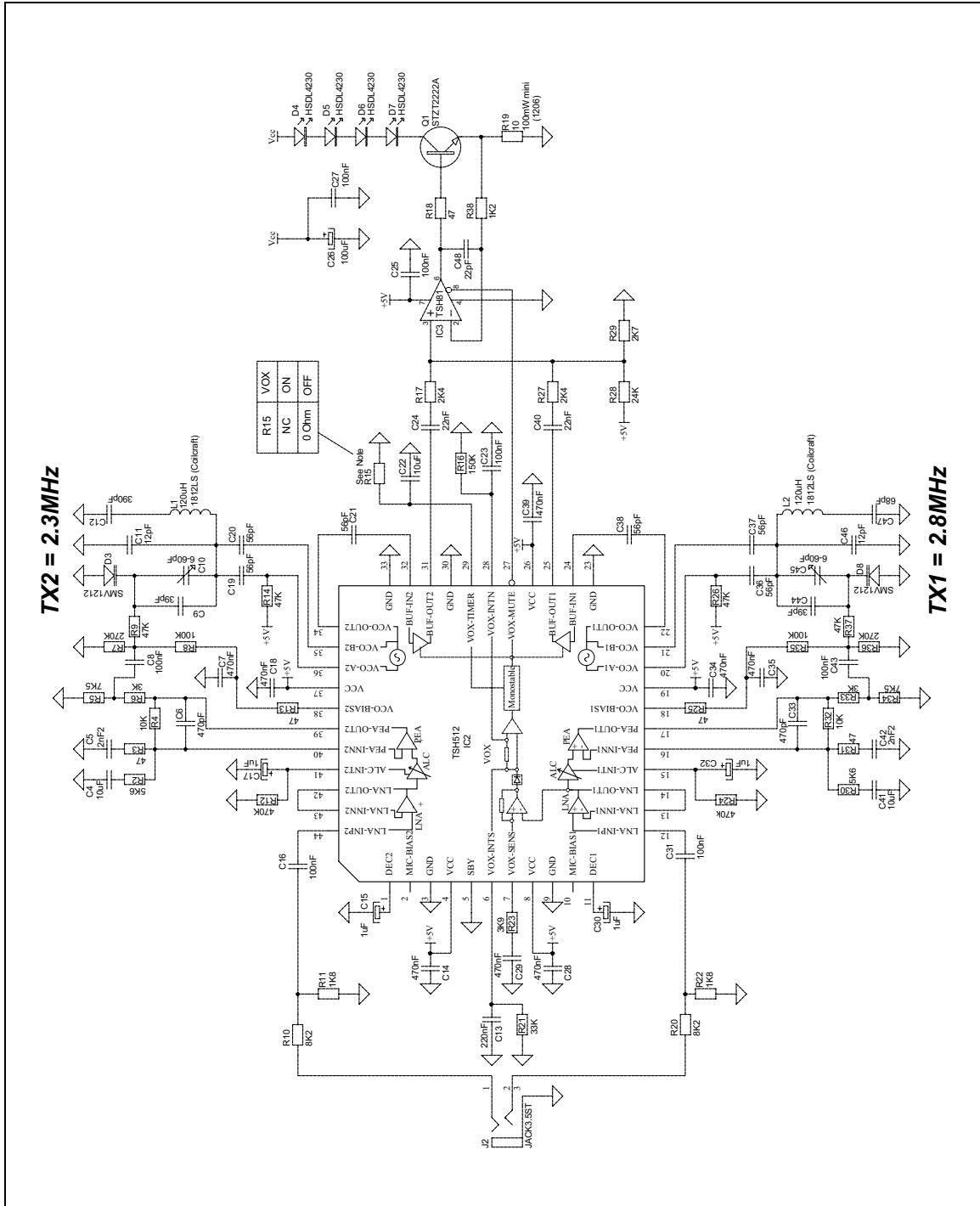

4.2 Sub-carrier generator application: voice-operated wireless camera

Thanks to its operating frequency, the TSH512 offers the possibility of generating usual audio sub-carriers for video applications (Figure 23). The camera can be voice-activated using the VOX-MUTE output of the TSH512. The TSH512 also provides bias, amplification, ALC for the electret microphone.

Figure 23. Typical block diagram for audio sub-carrier generator

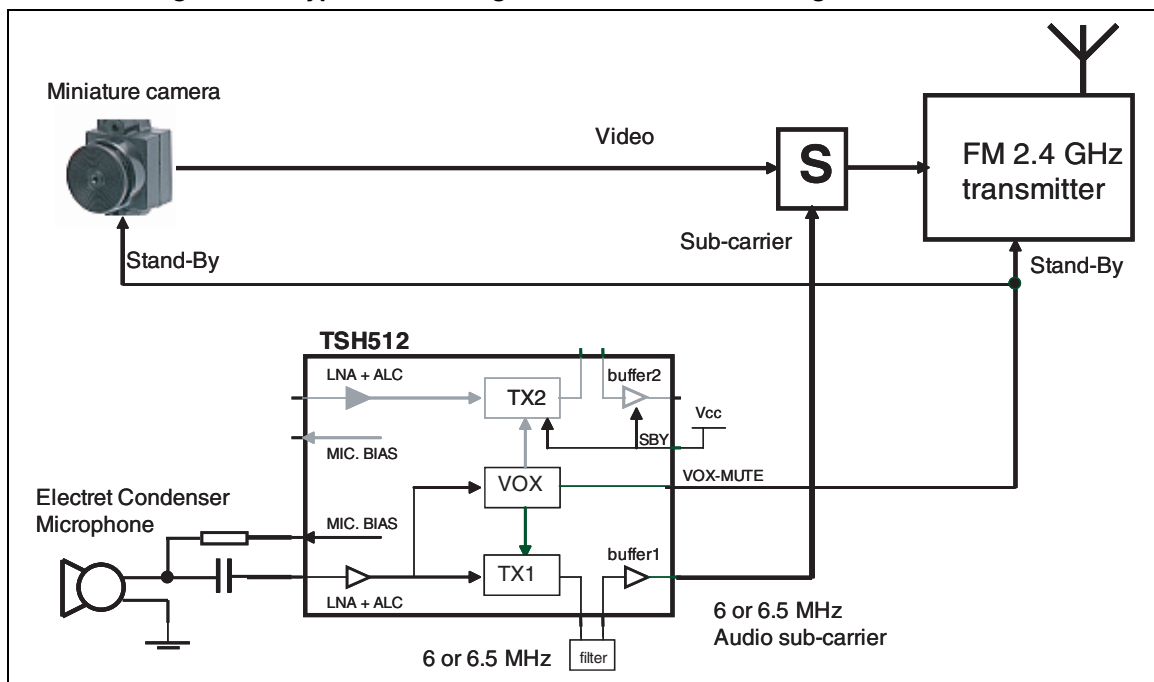

4.3 Multimedia application

4.3.1 Headset side

The TSH512 is used in mono mode to transmit the signal of the electret condenser microphone of the headset. The circuit is supplied by batteries and the VOX function switches off the output stages to save energy. The usual working frequency is 1.7 MHz for infrared mono operation.

Figure 24. Headset-side block diagram

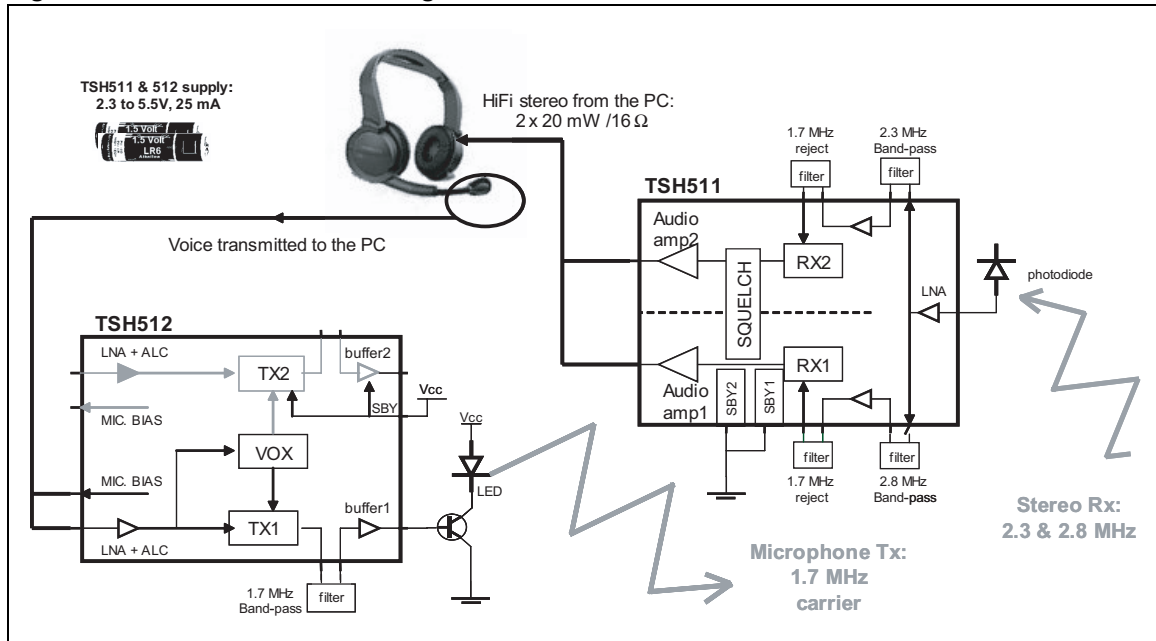

4.3.2 Computer side

In multimedia applications, the TSH512 transmits the hi-fi stereo from the PC to the headset.

Figure 25. Computer-side block diagram

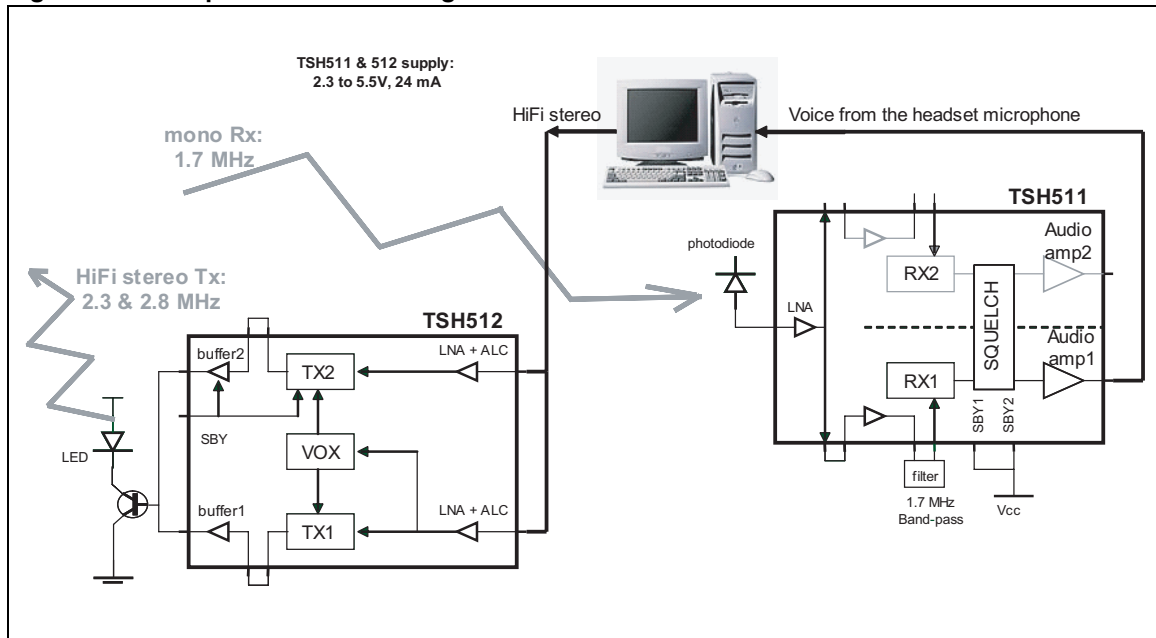

5 General description

The TSH512 is a 0.4- to 11-MHz dual FM analog transmitter. This circuit offers the functions needed for an advanced infrared STEREO transmitter. The access pins for each section allow high versatility and therefore a lot of applications: mono infrared transmitter, stereo transmitter, mono/stereo sub-carrier generator for video transmissions (for example the popular 2.4 GHz video links). The block diagram for the TSH512 is shown in [Figure 1 on page 4](#).

Each audio input is amplified with a **low noise amplifier** (LNA section) allowing connection to line level sources or directly to a microphone. Built-in MIC BIAS voltage references provide bias for electret condenser microphones (ECM) with a high power supply rejection ratio.

Each audio path also includes an **automatic level control** (ALC) to limit the over-modulation and the distortion on very high signal amplitudes. The following operational amplifier (PEA) allows a pre-emphasis transfer function before modulating the varicap diode.

Built-in voltage references (VCO-BIAS) offer a regulated voltage to bias the varicap diodes. The **voltage controlled oscillator** (VCO) is an integrated oscillator giving typically 600 mV peak-to-peak at 2.8 MHz.

The **output buffer** section linearly amplifies the FM carrier to provide a sinusoidal output. This sinusoidal signal reduces the inter-modulation products between the carriers, especially in two-way or in multi-carrier systems (see [Section 4: Application information on page 14](#)).

The **voice operated transmit** function (VOX) automatically detects when an audio signal appears over the background noise.

The standby of the second transmitter reduces consumption in mono operation.

5.1 LNA section: low noise amplifier

For each transmitter, the audio source is connected to the LNA. The LNA stage is a low noise operational amplifier typically usable with a gain from 0 to 40 dB.

Figure 26. LNA schematics

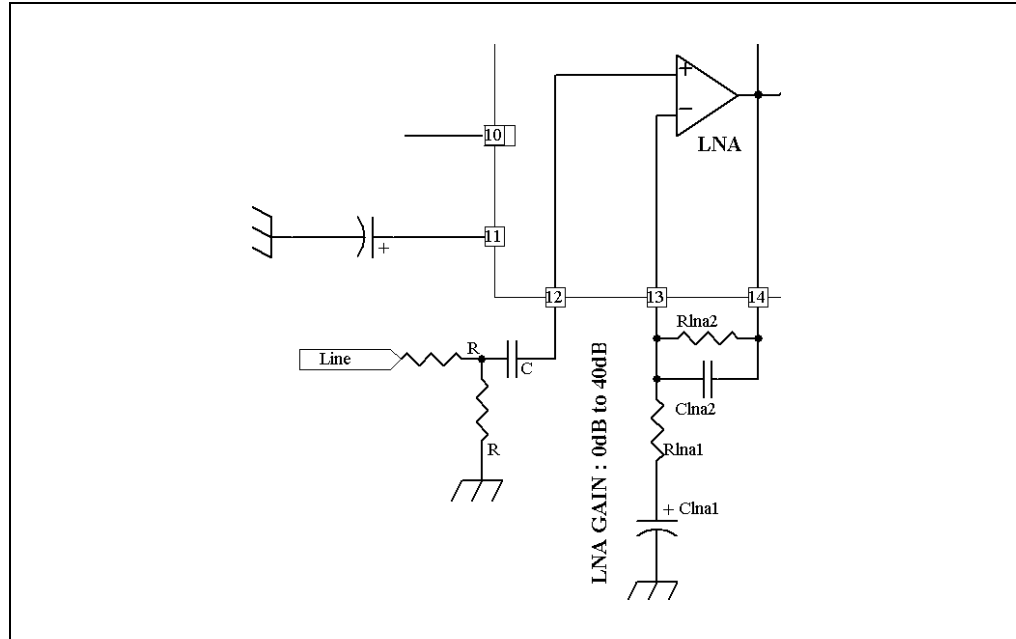

The LNA gain is given by:

$$G_{LNA} \text{ (dB)} = 20 \cdot \text{Log}(1 + R_{LNA2}/R_{LNA1})$$

The high-pass cut-off frequency is:

$$f_{HPF} = 1/(2 \cdot \pi \cdot R_{LNA1} \cdot C_{LNA1})$$

The lowpass filter cut-off frequency is:

$$f_{LPF} = 1/(2 \cdot \pi \cdot R_{LNA2} \cdot C_{LNA2})$$

If you connect an external circuit to the LNA output, the impedance of this external circuit should be higher than 10 mΩ and the capacitance lower than 50 pF in order to keep a good stability.

Note: The capacitor C must be connected directly to input pin 12.

5.2 Electret condenser microphone source

When an electret condenser microphone (ECM) is used, a high gain LNA is recommended, but low frequencies have to be attenuated. The ECM must be biased with a stable and clean reference voltage. The TSH512 provides the LNA and the MIC-BIAS sections to perform this function (see [Section 5.3. MIC-BIAS section: microphone bias voltage](#)).

Figure 27. Electret condenser microphone source

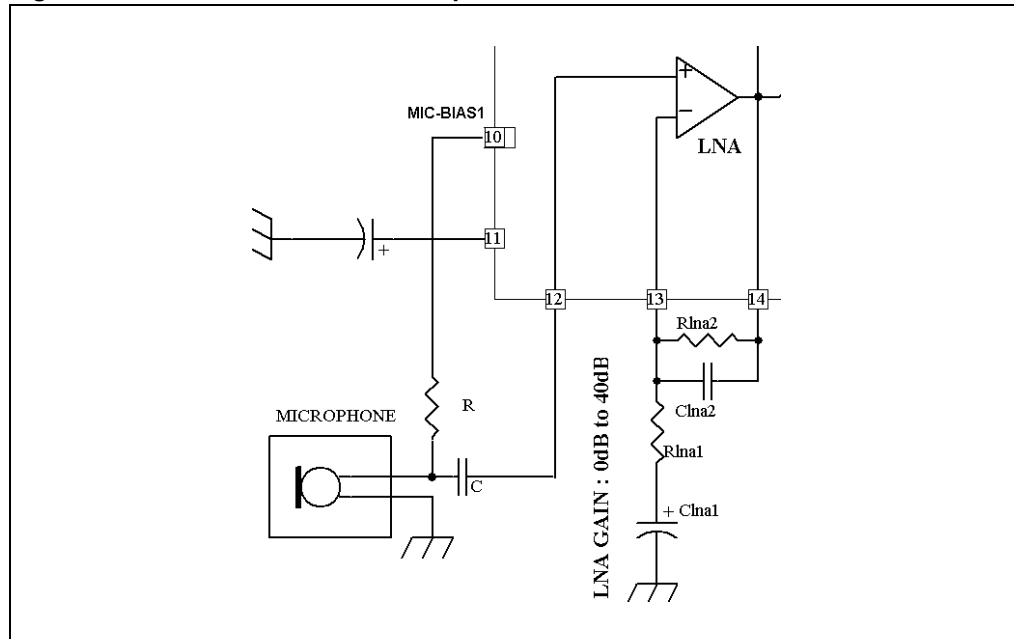

The capacitor C in series with the microphone stops the DC coming from MIC-BIAS.

The resistor R provides the DC from MIC-BIAS to supply the ECM.

Thanks to the automatic level control (ALC), the great variations of amplitude will not over-modulate the transmitter (refer to the [Section 5.4: ALC section: automatic level control](#)).

The self-adaptive VOX (voice operated transmit) offers automatic transmitting with a good discrimination of the background noise (see [Section 5.5: VOX description: voice operated transmit on page 21](#)).

5.3 MIC-BIAS section: microphone bias voltage

The MIC-BIAS bias voltages are dedicated to the bias of electret condenser microphones. These bias voltages on pin 10 for TX1 and pin 2 for TX2 exhibit a low voltage noise density of $22 \text{ nV}/\sqrt{\text{Hz}}$. This allows more than 55 dB S/N considering a bandwidth of 7 kHz ([Figure 27](#)).

The MIC-BIAS voltage is related to V_{CC} as follows (with $I_{\text{MIC-BIAS}} = 2.5 \text{ mA}$):

$$V_{\text{MIC-BIAS}} = 0.844 \cdot V_{CC} - 0.140 \text{ (volts)}$$

Moreover, the supply rejection ratio is guaranteed to be better than 50 dB without any decoupling capacitor. To address biasing of most of the microphones, the current drive capability is 2.5 mA. The MIC-BIAS voltage depends linearly on the supply voltage V_{CC} (refer to [Figure 11 on page 11](#)).

5.4 ALC section: automatic level control

Both transmitters of the TSH512 include an automatic level control (ALC). When the level of the audio signal is too high, the ALC compresses the signal in order to avoid over-modulation of the FM VCO. In this way, the ALC reduces the distortion and maintains a reduced transmit spectrum with very high amplitude signals.

Figure 28. Automatic level control schematics

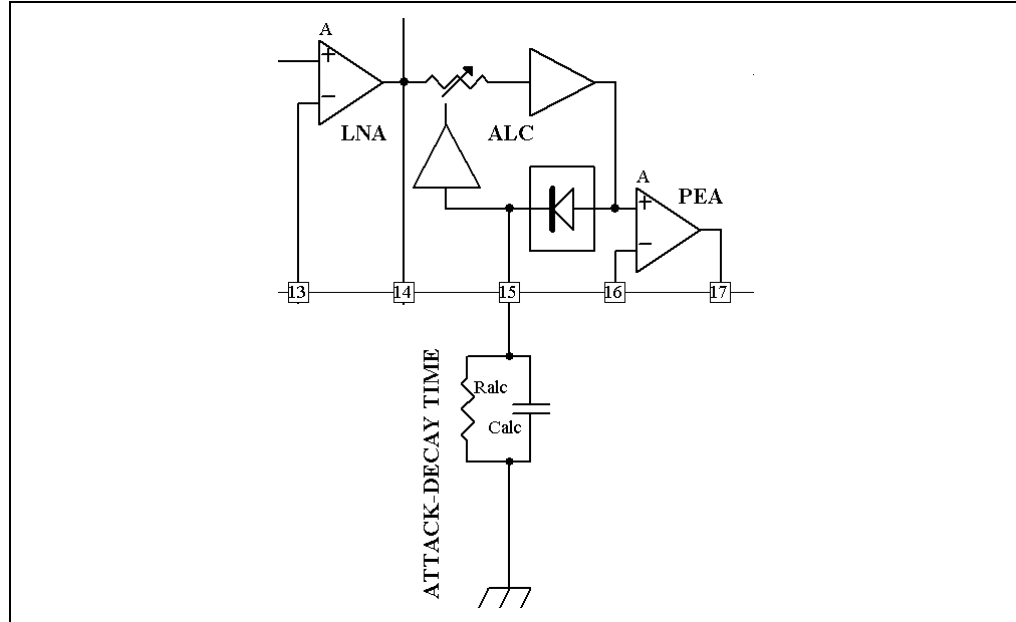

The ALC features a 20 dB gain and an output signal regulated to 700 mVpp in compression.

The attack time is the response time of the ALC to go from the linear amplification to the compression region. The attack time mainly depends on the capacitor value of C_{ALC} . A typical value of C_{ALC} is 1 μF with music as the audio signal (refer to [Figure 22 on page 15](#)).

The decay time is the response time the ALC requires to recover to full gain amplifying mode after being in compression mode. The decay time depends mainly on the R_{ALC} resistor value. A typical value of R_{ALC} is 470 k Ω with music as audio signal ([Figure 22](#)).

5.5 VOX description: voice operated transmit

The voice operated transmit (VOX) section reduces consumption when there is no audio signal to transmit. When the VOX detects that no audio signal is present, it mutes the output buffers of TX1 and TX2 and provides the logic signal VOX-MUTE to switch-off the external LED drivers if needed.

The audio signal of TX1 is amplified with a gain dependent on the values of R_{sens} and C_{sens} . R_{sens} and C_{sens} are connected to pin 7. The high-pass filtering has the following cut-off frequency:

$$f_{HPF} = \frac{1}{2\pi(R_{sens} \cdot C_{sens})}$$

Figure 29. VOX delay and sensitivity schematics

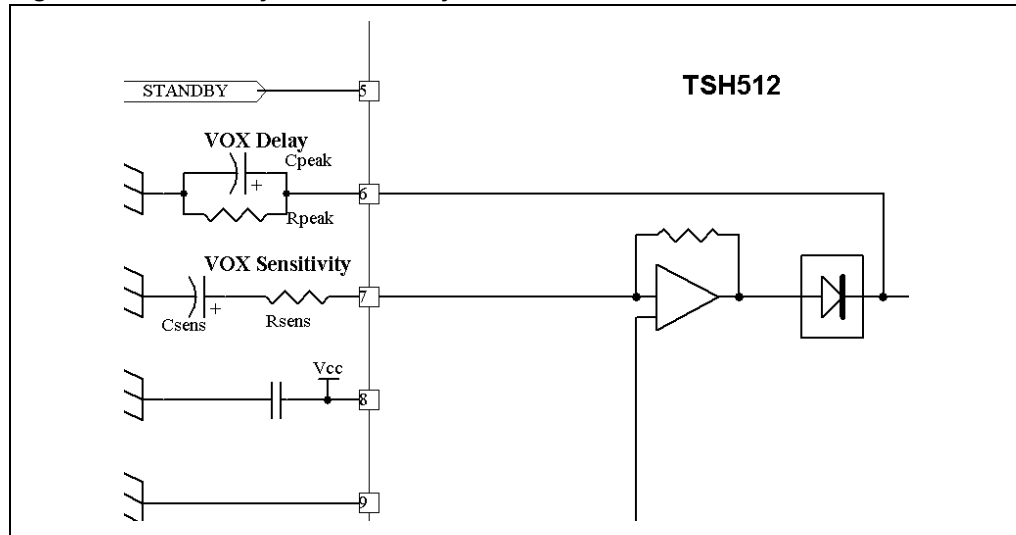

On pin 6, R_{peak} and C_{peak} integrate the rectified audio signal with a short time constant. This filtered signal follows the audio amplitude.

Figure 30. VOX integrator and monostable schematics

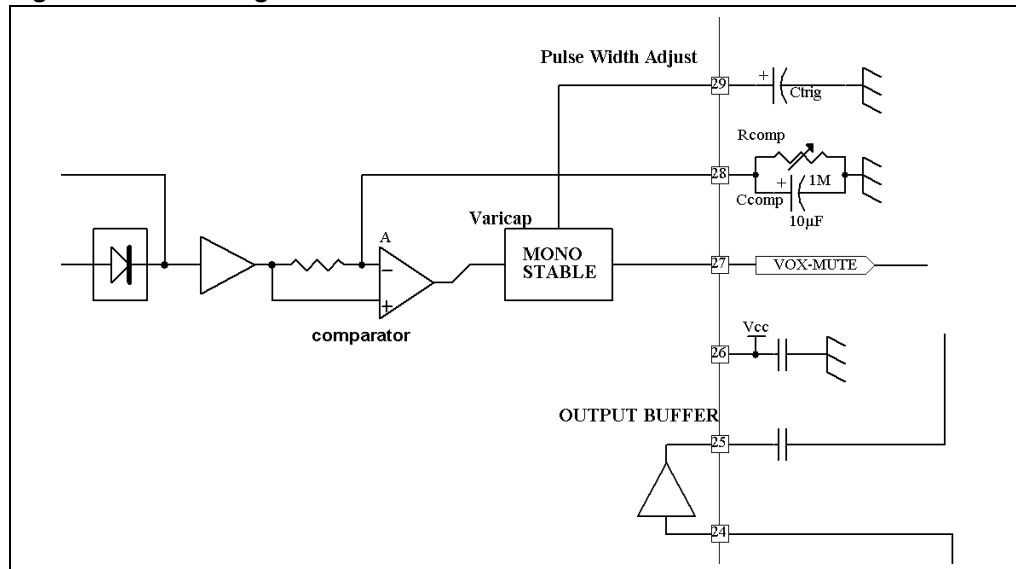

The self-adaptive VOX threshold is necessary because the ambient background noise variation is slow compared to the voice or the music. On pin 28, R_{COMP} and C_{COMP} integrate the amplitude to follow the background amplitude. Therefore, the comparator switches when an audio signal appears over the background noise. Referring to [Figure 2](#), C_{COMP} will be typically a 100 nF capacitor and R_{COMP} will be determined depending on the audio signal.

As soon as an audio signal is detected, the output of the monostable switches to "high" state and enables both output buffers. The monostable output is pin 27 and is called VOX-MUTE.

The monostable holds the TSH512 in transmit mode during a delay fixed by the value of C_{TRIG} connected to pin 29.

$$VOX_{DELAY} = \left(\frac{1.4V}{5\mu A} \right) \cdot C_{trig}$$

Note that the VOX function is activated when the audio signal enters the first transmitter TX1.

When the application needs a permanent transmission, it is possible to inhibit the VOX function, by removing the Ctrig capacitor and connecting pin 29 to ground.

As soon as the TSH512 is powered-on, the internal reset circuitry sets the VOX-MUTE to high state to enable transmission. The transmission remains during the monostable timing and continues if an audio signal triggers the monostable.

Figure 31. VOX state at power-on

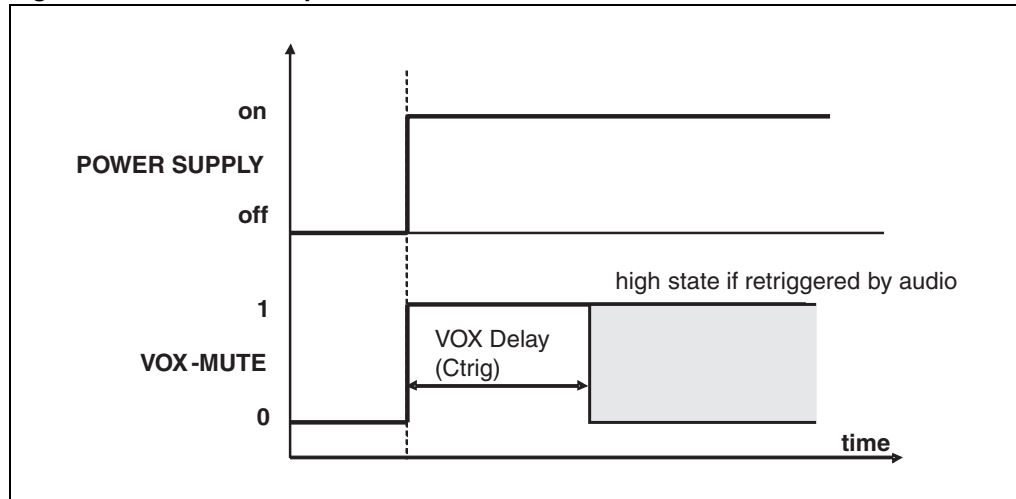

5.6 PEA section: pre-emphasis

The amplitude-regulated audio coming from the ALC feeds the positive input of the operational amplifier called PEA (pre-emphasis). The pre-emphasis consists in a high-pass filter in order to compensate the behavior of the FM transmission.

Figure 32. Pre-emphasis schematics

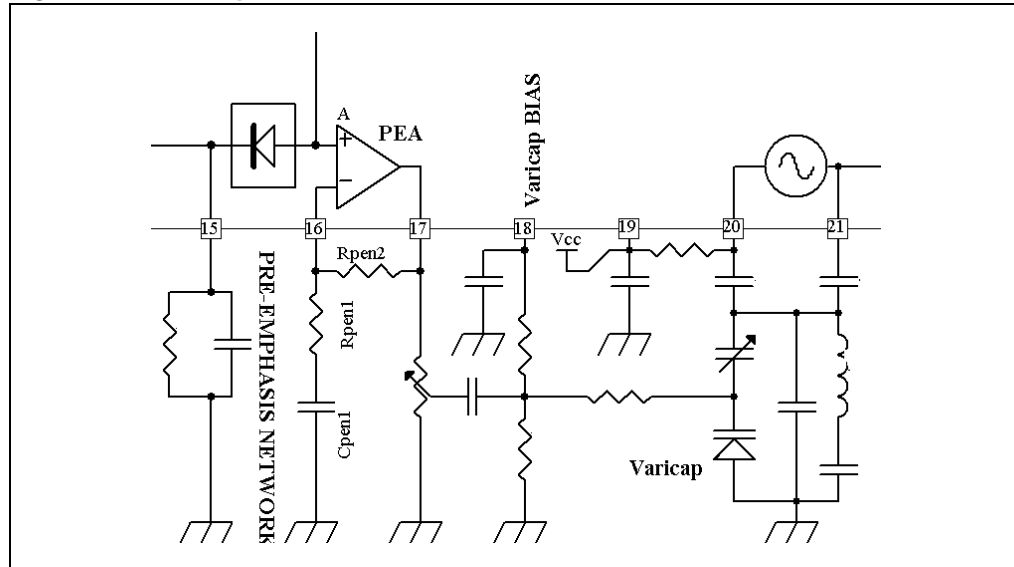

R_{PEA1} and C_{PEA1} set the time constant of the pre-emphasis as:

$$\tau = R_{PEA1} \cdot C_{PEA1}$$

50 μ s or 75 μ s time constants are generally used.

Choosing the gain of the PEA stage also allows one to set the right modulation level to the varicap diode. The gain in the passband is:

$$G_{PEA} = 1 + (R_{PEA2}/R_{PEA1})$$

5.7 VCO section: voltage-controlled oscillator

Each TSH512 transmitter has its own oscillator to generate the carrier. The audio signal is applied to the varicap diode to perform the frequency modulation. Thanks to the VCO-BIAS voltage reference, the DC bias of the varicap is stabilized. The high power supply rejection ratio (PSRR) of the VCO-BIAS ensures good immunity with the noise of the power supply.

Figure 33. VCO schematics

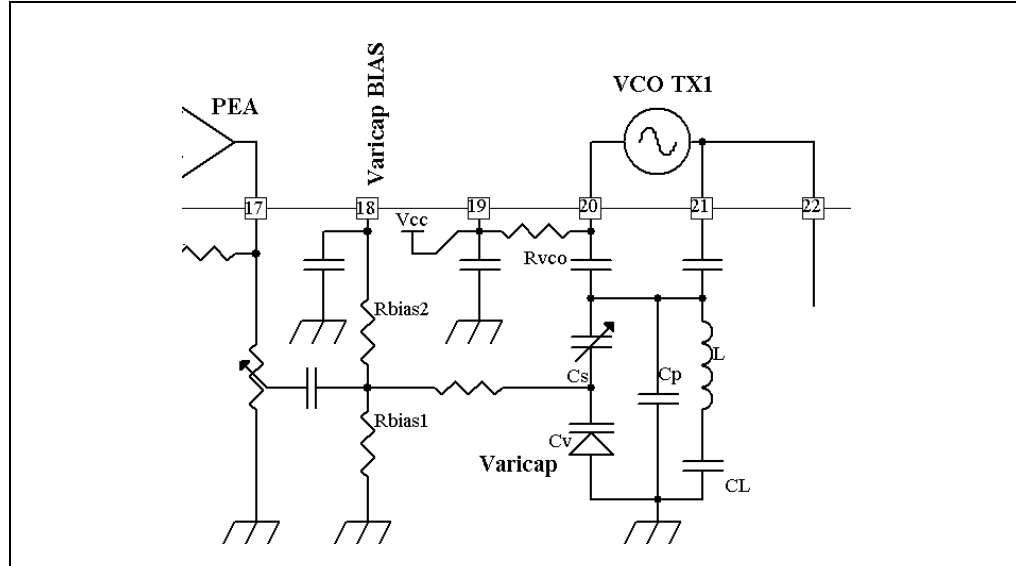

The generated frequency can be set from 400 kHz to 11 MHz by external components. Refer to [Table 1](#) for the usual frequencies in infrared audio.

The working frequency is:

$$f_{VCO} = \frac{1}{2\pi\sqrt{L \cdot C_t}}$$

where C_t is the total capacity of C_L , C_p , C_s and C_v :

$$C_t = 1/(1/C_c + 1/C_L) \text{ with } C_c = C_p + 1/(1/C_v + 1/C_s)$$

It is possible to use varicap diodes SMV1212 (Alpha Ind.) or ZC833 (Zetex).

Table 5. Usual infrared frequencies

IR frequency in MHz	Applications
1.6	AM mono
1.7	FM mono
2.3	FM right channel
2.8	FM left channel or mono

The output level of the VCO can be reduced by adding the resistor RVCO between pin 19 and pin 20 or between pin 36 and pin 37 for TX1 and TX2 respectively.

5.8 Output buffer section

The output buffers can deliver a sinusoidal signal with a $1.5 V_{pp}$ amplitude in a $1 k\Omega$ load. This impedance is compatible with popular biasing circuitry of external transistor drivers of IR LEDs.

The VOX-MUTE logic signal can be used to control the external LED drivers. When the audio is not present on the TX1 input, VOX-MUTE is in Low state, the TSH512's internal buffers are muted, and the external drivers can be switched off by controlling their bias.

5.9 SBY pin: standby for mono operation

A high state on the Standby pin (SBY) sets the second transmitter TX2 to power-down. The SBY pin is typically used when the TSH512 is used as a mono transmitter (that is, infrared microphone transmitter).

6 Package information

In order to meet environmental requirements, ST offers these devices in different grades of ECOPACK[®] packages, depending on their level of environmental compliance. ECOPACK[®] specifications, grade definitions and product status are available at: www.st.com. ECOPACK[®] is an ST trademark.

6.1 TQFP44 package information

Figure 34. TQFP44 package mechanical drawing

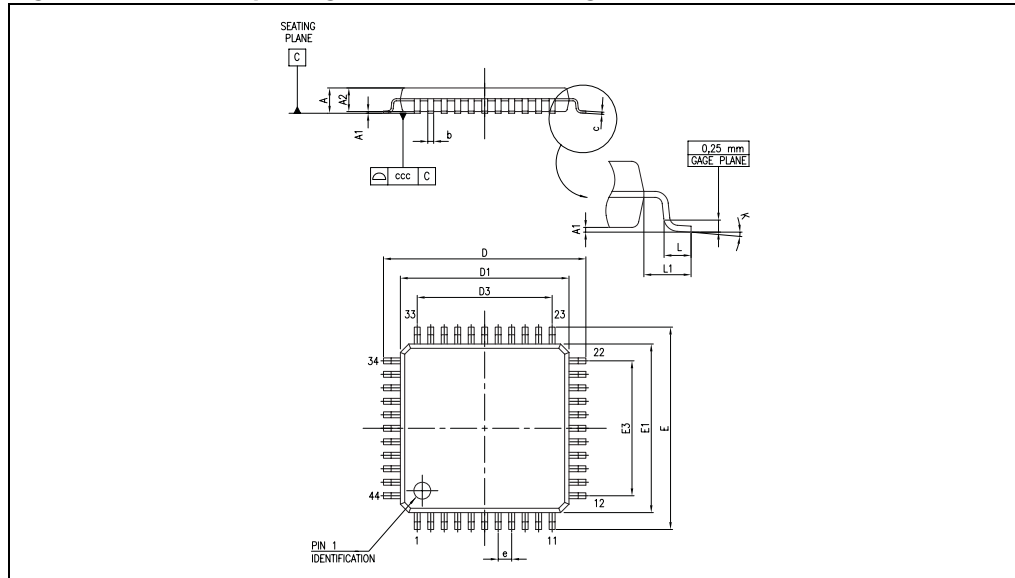

Table 6. TQFP44 package mechanical data

Ref.	Dimensions					
	Millimeters			Inches		
	Min.	Typ.	Max.	Min.	Typ.	Max.
A			1.6			0.063
A1	0.05		0.15	0.002		0.006
A2	1.35	1.40	1.45	0.053	0.055	0.057
b	0.30	0.37	0.45	0.012	0.015	0.018
c	0.09		0.20	0.004		0.008
D	11.80	12	12.20	0.465	0.472	0.480
D1	9.80	10.00	10.20	0.386	0.394	0.402
D3		8.00			0.315	
E	11.80	12.00	12.20	0.465	0.472	0.480
E1	9.80	10.00	10.20	0.386	0.394	0.402
E3		8.00			0.315	
e		0.80			0.031	
L	0.45	0.60	0.75	0.018	0.024	0.030
L1		1.00			0.039	
K	0°	3.5°	7°	0°	3.5°	7°
ccc			0.10			0.004

7 Ordering information

Table 7. Order codes

Part number	Temperature range	Package	Packing	Marking
TSH512CF	-40° C to +85° C	TQFP44	Tray	TSH512C
TSH512CFT			Tape & reel	
TSH512CYFT ⁽¹⁾		TQFP44 (automotive grade level)	Tape & reel	TSH512CYF

1. Qualification and characterization according to AEC Q100 and Q003 or equivalent, advanced screening according to AEC Q001 & Q 002 or equivalent.

8 Revision history

Table 8. Document revision history

Date	Revision	Changes
08-Aug-2001	1	First release corresponding to preliminary data version of datasheet.
09-Sep-2001	2	Datasheet updated for Maturity 30: <ul style="list-style-type: none"> – ESD sensitive device sentence added – 4 curves updated – Electrical parameters updated
01-Dec-2003	3	Specific content changes as follows: <ul style="list-style-type: none"> – Application diagrams updated – Releases on curves – Application schematic diagram update – Electrical parameters updated
01-Apr-2005	4	Pin connection updated on Figure 1 on page 4 . Rthja value added on Table 1 on page 3 . Schematic updated on Figure 2 on page 6 . Schematic updated on Figure 26 on page 19 .
14-Oct-2005	5	PPAP reference inserted in the datasheet, see order codes table.
13-Nov-2007	6	Document reformatted with minor text changes. Added footnote for automotive grade order codes to order codes table.
28-May-2009	7	Added data at $-40^{\circ}\text{C} < T_{\text{amb}} < +85^{\circ}\text{C}$ in Table 4 . Updated package mechanical drawing in Chapter 6: Package information .

Please Read Carefully:

Information in this document is provided solely in connection with ST products. STMicroelectronics NV and its subsidiaries ("ST") reserve the right to make changes, corrections, modifications or improvements, to this document, and the products and services described herein at any time, without notice.

All ST products are sold pursuant to ST's terms and conditions of sale.

Purchasers are solely responsible for the choice, selection and use of the ST products and services described herein, and ST assumes no liability whatsoever relating to the choice, selection or use of the ST products and services described herein.

No license, express or implied, by estoppel or otherwise, to any intellectual property rights is granted under this document. If any part of this document refers to any third party products or services it shall not be deemed a license grant by ST for the use of such third party products or services, or any intellectual property contained therein or considered as a warranty covering the use in any manner whatsoever of such third party products or services or any intellectual property contained therein.

UNLESS OTHERWISE SET FORTH IN ST'S TERMS AND CONDITIONS OF SALE ST DISCLAIMS ANY EXPRESS OR IMPLIED WARRANTY WITH RESPECT TO THE USE AND/OR SALE OF ST PRODUCTS INCLUDING WITHOUT LIMITATION IMPLIED WARRANTIES OF MERCHANTABILITY, FITNESS FOR A PARTICULAR PURPOSE (AND THEIR EQUIVALENTS UNDER THE LAWS OF ANY JURISDICTION), OR INFRINGEMENT OF ANY PATENT, COPYRIGHT OR OTHER INTELLECTUAL PROPERTY RIGHT.

UNLESS EXPRESSLY APPROVED IN WRITING BY AN AUTHORIZED ST REPRESENTATIVE, ST PRODUCTS ARE NOT RECOMMENDED, AUTHORIZED OR WARRANTED FOR USE IN MILITARY, AIR CRAFT, SPACE, LIFE SAVING, OR LIFE SUSTAINING APPLICATIONS, NOR IN PRODUCTS OR SYSTEMS WHERE FAILURE OR MALFUNCTION MAY RESULT IN PERSONAL INJURY, DEATH, OR SEVERE PROPERTY OR ENVIRONMENTAL DAMAGE. ST PRODUCTS WHICH ARE NOT SPECIFIED AS "AUTOMOTIVE GRADE" MAY ONLY BE USED IN AUTOMOTIVE APPLICATIONS AT USER'S OWN RISK.

Resale of ST products with provisions different from the statements and/or technical features set forth in this document shall immediately void any warranty granted by ST for the ST product or service described herein and shall not create or extend in any manner whatsoever, any liability of ST.

ST and the ST logo are trademarks or registered trademarks of ST in various countries.

Information in this document supersedes and replaces all information previously supplied.

The ST logo is a registered trademark of STMicroelectronics. All other names are the property of their respective owners.

© 2009 STMicroelectronics - All rights reserved

STMicroelectronics group of companies

Australia - Belgium - Brazil - Canada - China - Czech Republic - Finland - France - Germany - Hong Kong - India - Israel - Italy - Japan - Malaysia - Malta - Morocco - Philippines - Singapore - Spain - Sweden - Switzerland - United Kingdom - United States of America

www.st.com

