

EM351/EM357

802.15.4 and ZigBee Compliant SoC Family

Radio
2.4 GHz

Fact Sheet

PRELIMINARY

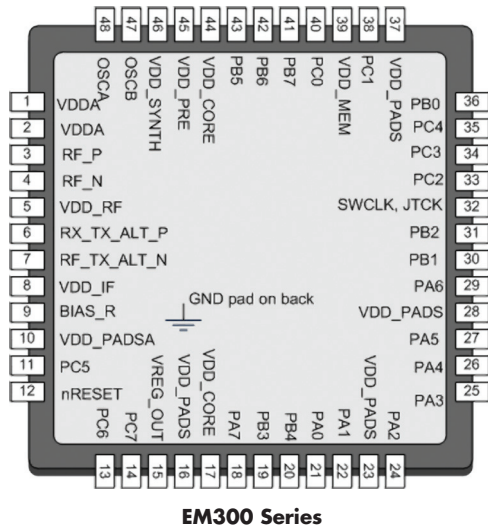

EM300 Series

Key Features

- Industry's first ARM Cortex-M3 based family of SoCs
- Exceptional, industry leading RF performance
- 128 KB (EM351) and 192 KB (EM357) flash variants available
- 12 KB RAM
- High code density to accommodate the most sophisticated applications
- Lowest deep sleep current and multiple sleep modes
- Excellent immunity to other 2.4 GHz devices for reliable co-existence
- Built in memory protection
- Flexible Antenna Interface allows easy antenna connection with or without PA
- Flash guaranteed for 20,000 write cycles, enhances token storage capability via SIM-EEPROM
- AES 128 hardware encryption engine with true random number generator
- Hardware supported network level debugging with "InSight Port"
- Capable of being ZigBee Coordinator (ZC), full function device (FFD) and reduced function device (RFD)

Overview—EM300 Series ZigBee SoCs

The EM351 and EM357 ZigBee chips from Ember are the industry's first ARM Cortex-M3 based family of SoCs delivering unmatched performance, power consumption and code density in a compact package.

The EM351 and EM357 combine a 2.4 GHz IEEE 802.15.4 radio transceiver with a 32-bit microprocessor, Flash memory and RAM with powerful hardware supported network-level debugging features. This, combined with the powerful ecosystem of ARM tools, enables OEMs to simplify development and accelerate time to market.

The EM300 family is tightly integrated with EmberZNet PRO, Ember's ZigBee compliant mesh networking software which is the most deployed ZigBee platform in the market.

- **EM351**—integrates a programmable ARM Cortex-M3 processor, IEEE 802.15.4 RF radio transceiver, 128 KB Flash and 12 KB RAM and EmberZNet PRO network protocol stack supporting the ZigBee PRO Feature Set
- **EM357**—optimized for applications that require more memory, it has 192 KB Flash but incorporates all the other characteristics and features of the EM351

Low Power, High Total Link Budget, Robust Co-existence

The EM300 family delivers outstanding, industry leading performance with a configurable Total Link Budget up to 109 dB, while maintaining the highest level of integration requiring minimal external components. The high transmit power virtually eliminates the need for an external Power Amplifier (PA) in most applications especially in Europe and Asia. Where PA is required, the product is designed to allow an external PA or Front End Module (FEM) to be easily connected.

The EM300 family offers the lowest sleep current of any ZigBee system in the market. Developers can take advantage of the integrated EmberZNet PRO networking library to incorporate short wake cycles. Also, integrated clocks provide optimized wake-sleep cycles to conserve power. The integrated voltage regulator supports a wide range of operating voltages allowing hardware designs to be optimized for lithium-ion or alkaline batteries without additional circuitry.

The EM351 and EM357 ZigBee SoCs are extremely robust providing exceptional immunity and reliable co-existence with other 2.4 GHz devices in the environment.

ARM Cortex-M3 Processor

The integrated 32-bit ARM Cortex-M3 processor provides a very high code density allowing larger applications, while delivering exceptional performance in a small, power efficient RISC core. Well recognized for its outstanding computational performance and exceptional system response to interrupts the ARM processor enables a small core footprint and best in class code density. The performance of the Cortex-M3 processor coupled with the performance of the Ember stack helps deliver network throughput and lower latencies that are unmatched in the industry.

Continued on back

ZigBee Compliant Stack & Development Environment

The EM300 series comes tightly integrated with EmberZNet PRO, the industry's most deployed and field proven ZigBee compliant stack supporting the ZigBee PRO Feature Set and enhanced with unique Ember innovations. Enabling larger, denser, sleepier, more mobile, secure and resilient ZigBee Networks, EmberZNet PRO is a complete ZigBee protocol software package containing all the elements required for sophisticated mesh networking applications on Ember's silicon platforms.

Ember's InSight™ Development Environment is supported by a variety of industry leading IDE's to provide best in class tools to build and debug embedded ZigBee applications. The InSight Desktop tool is designed for developing, compiling, loading and debugging software onto multiple nodes in a networked environment. The availability of standard ARM tools and the ARM serial wire and JTAG debug capabilities provides complete instruction level and register level debugging capabilities. The EM351 and EM357 support special hardware based network debugging capabilities to help identify complex network level interactions that cannot be caught by examining a single node.

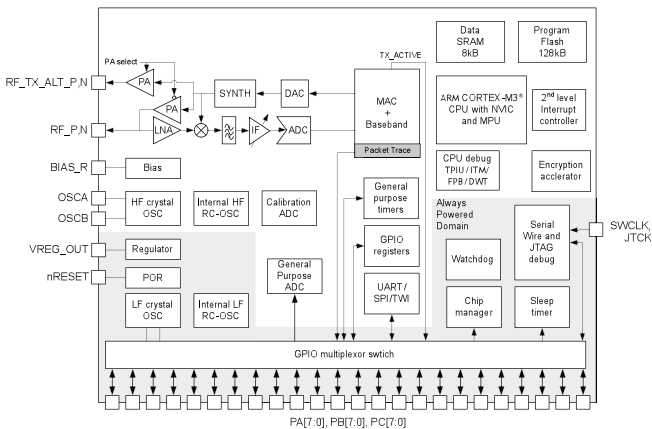

About Ember

Ember Corporation www.ember.com develops ZigBee wireless networking technology that enables companies involved in energy technologies—enertech—to help make buildings and homes smarter, consume less energy, operate more efficiently, and keep people comfortable and safe. Ember's low-power wireless technology can be embedded into a wide variety of devices to be part of a self-organizing mesh network. Ember is headquartered in Boston and has its radio development center in Cambridge, England, and distributors worldwide. The company is a promoter and Board member of the ZigBee Alliance and its platform is the "Golden Suite" for 802.15.4/ZigBee interoperability testing.

US Headquarters

47 Farnsworth Street
Boston, MA 02210
USA
+1 617 951 0200
www.ember.com

European office

Cambridge Science Park
Unit 300, Milton Rd.
Cambridge, CB4 0XL, UK
+44 (0) 1223 423322
www.ember.com

Asian office

22/F, 3 Lockheart Rd.
Wanchai, Hong Kong
China
+852-2862 8075
www.ember.com

General Characteristics

Deep Sleep Current	1 uA max
Rx Current	25 mA
Tx Current	31 mA at +3 dBm
Crystal Frequency	24 MHz
Operating Temperature Range	-40 to +85 C
Voltage	2.1 to 3.6 V
Package	7 mm x 7 mm 48 pin QFN

RF Characteristics

Data Rate	250 kbps
Frequency	2400 to 2500 16 total 5 MHz Channels
Rx Sensitivity	-99 dBm Normal Mode -101 dBm Boost Mode
Adj Channel Rejection	35 dB
Alt Channel Rejection	43 dB
802.11g Rejection	35 dB
Tx Power	-55 dBm to +5 dBm Normal Mode -55 dBm to +8 dBm Boost Mode
Total Link Budget	Up to 109 dB

Micro Characteristics

Operating Frequency	12 MHz
Flash	EM351 128 KB EM357 192 KB
RAM	12 KB



EM300-FAMILY-0910
Information contained in this document is subject to change without notice and is presented without express or implied warranty. Ember, EmberZNet and InSight are trademarks of Ember Corporation. All other trademarks are the property of their respective owners. Copyright 2009, Ember Corporation. All rights reserved.