

# DATA SHEET



## GaAs INTEGRATED CIRCUIT $\mu$ PG2183T6C

### 4 W HIGH POWER SP4T SWITCH

#### DESCRIPTION

The  $\mu$ PG2183T6C is a GaAs MMIC SP4T (Single Pole Four Throw) switch which was designed for digital cellular phone applications.

This device can operate from 0.5 to 2.5 GHz, with low insertion loss and high isolation.

This device is housed in a 16-pin plastic QFN (Quad Flat Non-leaded) (T6C) package, and is suitable for high-density surface mounting.

#### FEATURES

- Supply voltage :  $V_{bat} = 2.9$  to  $3.2$  V (3.0 V TYP.)
- Standby mode voltage :  $V_{DD} (H) = 1.7$  to  $V_{bat}$  V (2.65 V TYP.)  
:  $V_{DD} (L) = 0$  to  $+0.05$  V (0 V TYP.)
- Switch control voltage :  $V_{cont} (H) = 1.7$  to  $V_{bat}$  V (2.65 V TYP.)  
:  $V_{cont} (L) = 0$  to  $+0.05$  V (0 V TYP.)
- Operating Frequency :  $f = 0.5$  to  $2.5$  GHz
- Low insertion loss :  $L_{ins1} = 0.4$  dB TYP. @  $f = 0.5$  to  $1.0$  GHz,  $V_{bat} = 3.0$  V,  $V_{DD} = V_{cont} (H) = 2.65$  V,  $V_{cont} (L) = 0$  V  
:  $L_{ins2} = 0.55$  dB TYP. @  $f = 1.0$  to  $2.0$  GHz,  $V_{bat} = 3.0$  V,  $V_{DD} = V_{cont} (H) = 2.65$  V,  $V_{cont} (L) = 0$  V  
:  $L_{ins3} = 0.7$  dB TYP. @  $f = 2.0$  to  $2.5$  GHz,  $V_{bat} = 3.0$  V,  $V_{DD} = V_{cont} (H) = 2.65$  V,  $V_{cont} (L) = 0$  V
- High isolation :  $ISL1 = 24$  dB TYP. @  $f = 0.5$  to  $1.0$  GHz,  $V_{bat} = 3.0$  V,  $V_{DD} = V_{cont} (H) = 2.65$  V,  $V_{cont} (L) = 0$  V  
:  $ISL2 = 19$  dB TYP. @  $f = 1.0$  to  $2.0$  GHz,  $V_{bat} = 3.0$  V,  $V_{DD} = V_{cont} (H) = 2.65$  V,  $V_{cont} (L) = 0$  V  
:  $ISL3 = 17$  dB TYP. @  $f = 2.0$  to  $2.5$  GHz,  $V_{bat} = 3.0$  V,  $V_{DD} = V_{cont} (H) = 2.65$  V,  $V_{cont} (L) = 0$  V
- Power Handling :  $P_{in} (0.1 \text{ dB}) = +37.5$  dBm TYP. @  $f = 0.9$  GHz,  $V_{bat} = 3.0$  V,  $V_{DD} = V_{cont} (H) = 2.65$  V,  $V_{cont} (L) = 0$  V  
:  $P_{in} (0.1 \text{ dB}) = +35.0$  dBm TYP. @  $f = 1.8$  GHz,  $V_{bat} = 3.0$  V,  $V_{DD} = V_{cont} (H) = 2.65$  V,  $V_{cont} (L) = 0$  V
- High-density surface mounting : 16-pin plastic QFN (T6C) package ( $3.0 \times 3.0 \times 0.75$  mm)

#### APPLICATIONS

- Digital cellular phone etc.

#### ORDERING INFORMATION

Part Number	Order Number	Package	Marking	Supplying Form
$\mu$ PG2183T6C-E2	$\mu$ PG2183T6C-E2-A	16-pin plastic QFN (T6C) (Pb-Free)	2183	<ul style="list-style-type: none"><li>• Embossed tape 12 mm wide</li><li>• Pin 13, 14, 15 and 16 face the perforation side of the tape</li><li>• Qty 3 kpcs/reel</li></ul>

**Remark** To order evaluation samples, please contact your nearby sales office.

Part number for sample order:  $\mu$ PG2183T6C-A

**Caution** Although this device is designed to be as robust as possible, ESD (Electrostatic Discharge) can damage this device. This device must be protected at all times from ESD. Static charges may easily produce potentials of several kilovolts on the human body or equipment, which can discharge without detection. Industry-standard ESD precautions must be employed at all times.

The information in this document is subject to change without notice. Before using this document, please confirm that this is the latest version.

**PIN CONNECTIONS AND INTERNAL BLOCK DIAGRAM**

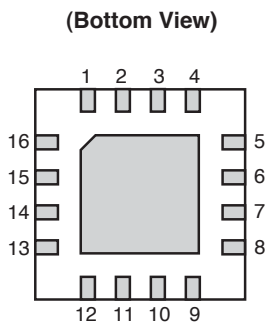
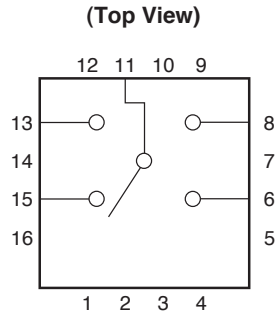
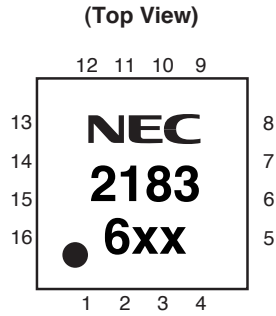

Pin No.	Pin Name
1	GND (N.C.)
2	V <sub>DD</sub>
3	V <sub>cont2</sub>
4	V <sub>cont1</sub>
5	GND
6	RF4
7	GND (N.C.)
8	RF3
9	GND (N.C.)
10	GND (N.C.)
11	ANT
12	GND (N.C.)
13	RF1
14	GND (N.C.)
15	RF2
16	V <sub>bat</sub>

**Remark** Exposed pad : GND

**SW TRUTH TABLE**

V <sub>bat</sub>	V <sub>DD</sub>	V <sub>cont1</sub>	V <sub>cont2</sub>	RF Path	Mode
High	High	Low	Low	ANT-RF1	Active mode
High	High	Low	High	ANT-RF2	Active mode
High	High	High	Low	ANT-RF3	Active mode
High	High	High	High	ANT-RF4	Active mode
High	Low	Low	Low	ANT-RF1	Standby mode
High	Low	Low	High	ANT-RF2	Standby mode
High	Low	High	Low	ANT-RF3	Standby mode
High	Low	High	High	ANT-RF4	Standby mode

**ABSOLUTE MAXIMUM RATINGS ( $T_A = +25^\circ\text{C}$ , unless otherwise specified)**

Parameter	Symbol	Ratings	Unit
Battery Voltage	$V_{\text{bat}}$	+4.2	V
Standby Mode Voltage	$V_{\text{DD}}$	+4.2	V
Switch Control Voltage	$V_{\text{cont}}$	+4.2	V
Input Power	$P_{\text{in}}$	+38	dBm
Operating Ambient Temperature	$T_A$	-45 to +85	$^\circ\text{C}$
Storage Temperature	$T_{\text{stg}}$	-55 to +150	$^\circ\text{C}$

**RECOMMENDED OPERATING RANGE ( $T_A = +25^\circ\text{C}$ , unless otherwise specified)**

Parameter	Symbol	MIN.	TYP.	MAX.	Unit
Battery Voltage	$V_{\text{bat}}$	2.9	3.0	3.2	V
Standby Mode Voltage (H)	$V_{\text{DD (H)}}$	1.7	2.65	$V_{\text{bat}}$	V
Standby Mode Voltage (L)	$V_{\text{DD (L)}}$	0	0	0.05	V
Switch Control Voltage (H)	$V_{\text{cont (H)}}$	1.7	2.65	$V_{\text{bat}}$	V
Switch Control Voltage (L)	$V_{\text{cont (L)}}$	0	0	0.05	V

**ELECTRICAL CHARACTERISTICS**

(TA = +25°C, Vbat = 3.0 V, VDD = 2.65 V, Vcont (H) = 2.65 V, Vcont (L) = 0 V, Zo = 50 Ω, DC blocking capacitors = 56 pF, unless otherwise specified)

Parameter	Symbol	Test Conditions	MIN.	TYP.	MAX.	Unit
Insertion Loss 1	L <sub>ins1</sub>	f = 0.5 to 1.0 GHz	-	0.4	0.55	dB
Insertion Loss 2	L <sub>ins2</sub>	f = 1.0 to 2.0 GHz	-	0.55	0.8	dB
Insertion Loss 3	L <sub>ins3</sub>	f = 2.0 to 2.5 GHz	-	0.7	0.95	dB
Isolation 1	ISL1	f = 0.5 to 1.0 GHz	22	24	-	dB
Isolation 2	ISL2	f = 1.0 to 2.0 GHz	17	19	-	dB
Isolation 3	ISL3	f = 2.0 to 2.5 GHz	15	17	-	dB
Input Return Loss	RL <sub>in</sub>	f = 0.5 to 2.5 GHz	15	19	-	dB
Output Return Loss	RL <sub>out</sub>	f = 0.5 to 2.5 GHz	15	19	-	dB
0.1 dB Loss Compression Input Power 1 <sup>Note</sup>	P <sub>in (0.1 dB) 1</sub>	f = 0.9 GHz	+37.0	+37.5	-	dBm
0.1 dB Loss Compression Input Power 2 <sup>Note</sup>	P <sub>in (0.1 dB) 2</sub>	f = 1.8 GHz	+34.0	+35.0	-	dBm
Harmonics 1	2f0	f = 0.9 GHz, P <sub>in</sub> = 34.5 dBm	-	-75	-65	dBc
	3f0		-	-75	-65	dBc
Harmonics 2	2f0	f = 1.8 GHz, P <sub>in</sub> = 31.5 dBm	-	-72	-62	dBc
	3f0		-	-75	-62	dBc
Battery Current 1	I <sub>bat1</sub>	Active Mode, No RF	-	0.55	1.5	mA
Battery Current 2	I <sub>bat2</sub>	Standby Mode, No RF	-	-	10	μA
Switched Supply Current 1	I <sub>DD1</sub>	V <sub>DD</sub> : High, No RF	-	0	0.1	mA
Switched Supply Current 2	I <sub>DD2</sub>	V <sub>DD</sub> : Low, No RF	-	0	0.1	mA
Control Current 1-1	I <sub>cont 1-1</sub>	V <sub>cont1</sub> : High, No RF	-100	0	100	μA
Control Current 1-2	I <sub>cont 1-2</sub>	V <sub>cont1</sub> : Low, No RF	-100	0	100	μA
Control Current 2-1	I <sub>cont 2-1</sub>	V <sub>cont2</sub> : High, No RF	-100	0	100	μA
Control Current 2-2	I <sub>cont 2-2</sub>	V <sub>cont2</sub> : Low, No RF	-100	0	100	μA
Switch Control Speed	t <sub>sw</sub>	50% CTL to 90/10%	-	0.5	5.0	μs
Startup Time	-	Time for the switch to be operational from that the switched supply voltage (V <sub>DD</sub> ) goes high.	-	-	100	μs

**Note** P<sub>in (0.1 dB)</sub> is the measured input power level when the insertion loss increases 0.1 dB more than that of linear range.

**Caution** It is necessary to use DC blocking capacitors, with this device.

The value of DC blocking capacitors should be chosen to accommodate the frequency of operation, bandwidth, switching speed and the condition with actual board of your system. The range of recommended DC blocking capacitor value is less than 56 pF.

**EVALUATION CIRCUIT**

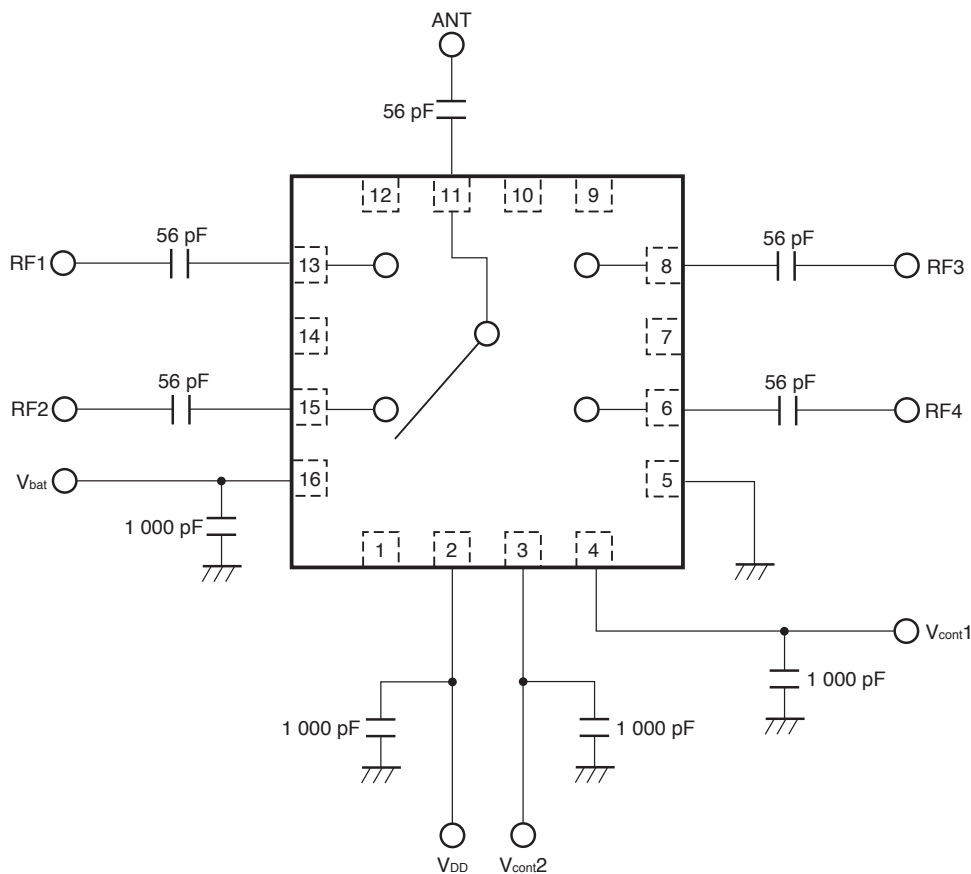

The application circuits and their parameters are for reference only and are not intended for use in actual design-ins.

**APPLICATION INFORMATION**

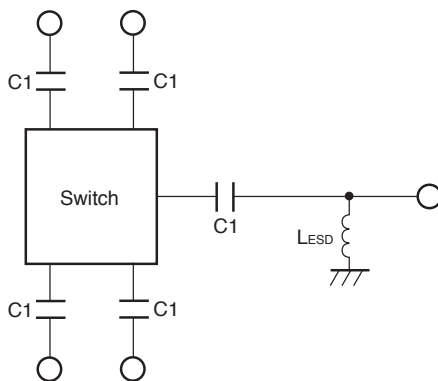

- LESD provides a means to increase the ESD protection on a specific RF port, typically the port attached to the antenna.
- The value may be tailored to provide specific electrical responses.
- The RF ground connections should be kept as short as possible and connected to directly to a good RF ground for best performance.

**PERFORMANCE DATA**

( $T_A = +25^\circ\text{C}$ ,  $V_{\text{bat}} = 3.0\text{ V}$ ,  $V_{\text{DD}} = 2.65\text{ V}$ ,  $V_{\text{cont (H)}} = 2.65\text{ V}$ ,  $V_{\text{cont (L)}} = 0\text{ V}$ , DC blocking capacitors = 56 pF, unless otherwise specified)

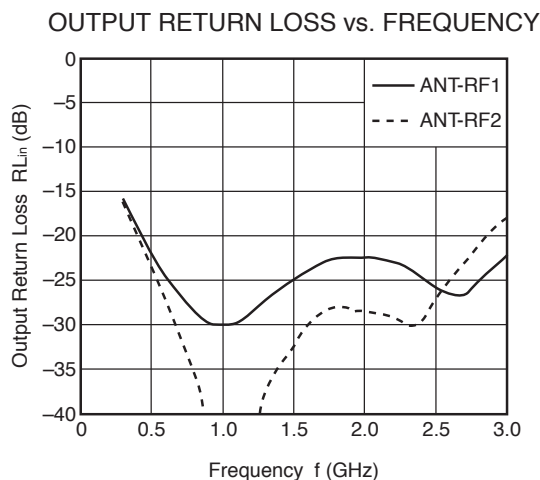
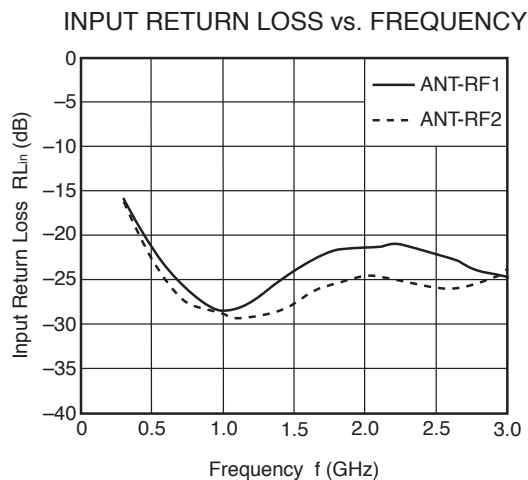
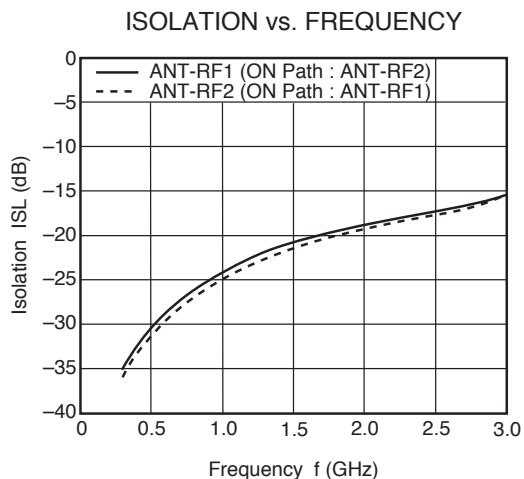
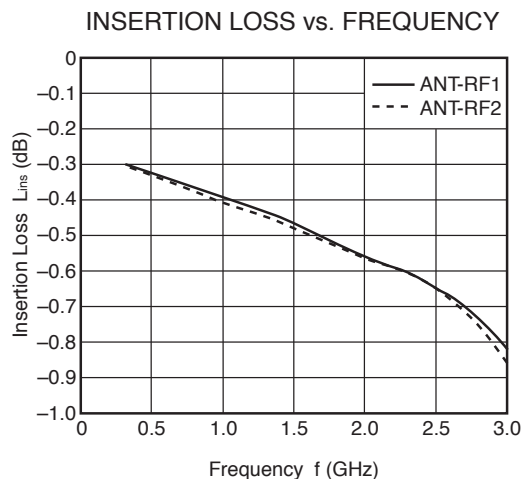

**Remark** The graphs indicate nominal characteristics.

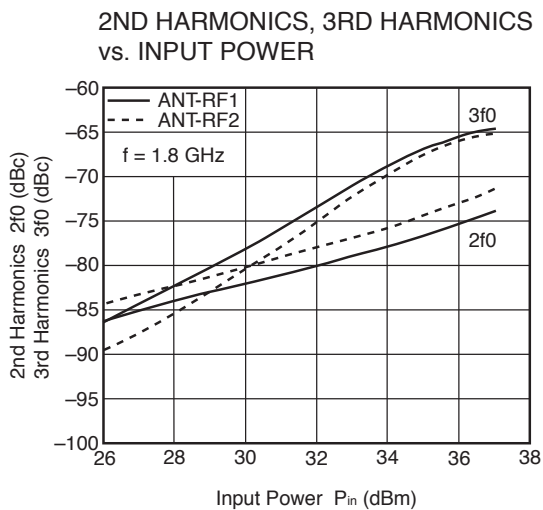
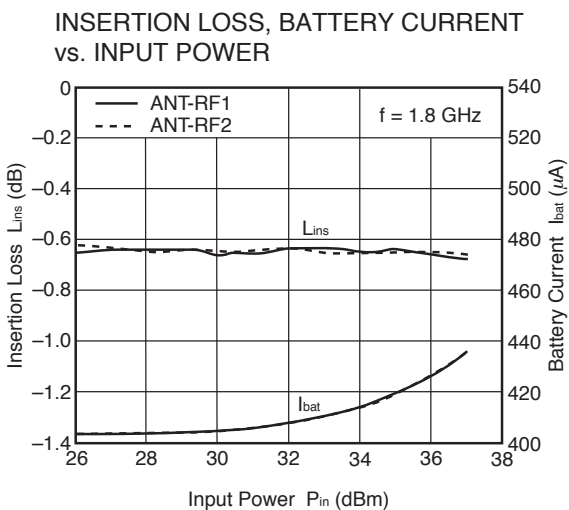
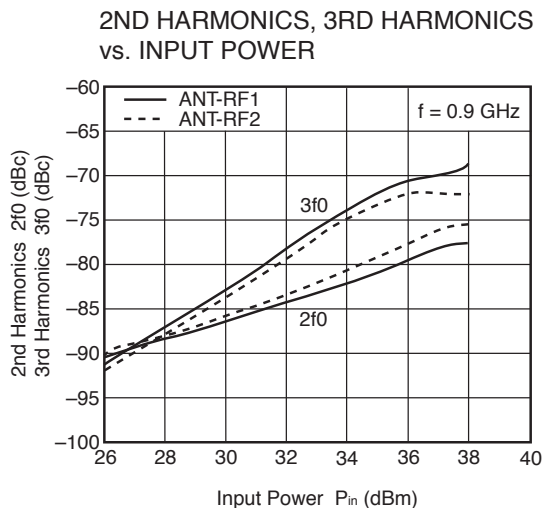
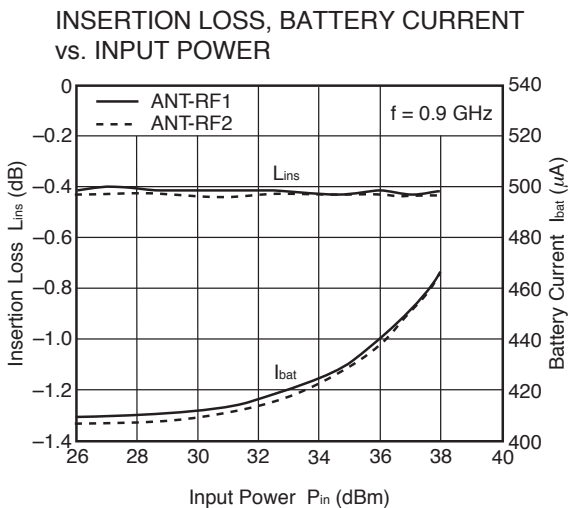

**Remark** The graphs indicate nominal characteristics.

**REFERENCE DATA** ( $T_A = +25^\circ\text{C}$ ,  $V_{DD} = 1.8\text{ V}$ ,  $V_{\text{cont}}(\text{H}) = 1.8\text{ V}$ ,  $V_{\text{cont}}(\text{L}) = 0\text{ V}$ , DC blocking capacitors = 56 pF, unless otherwise specified)

INSERTION LOSS vs. BATTERY VOLTAGE

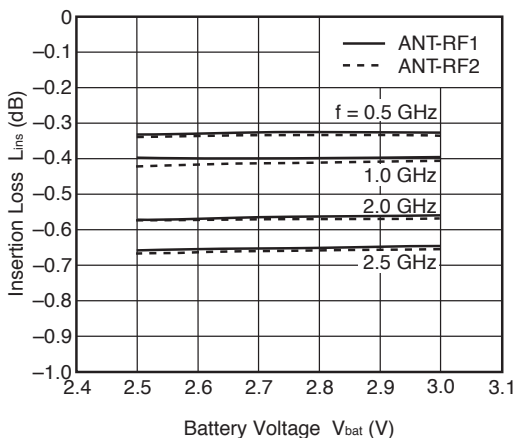

ISOLATION vs. BATTERY VOLTAGE

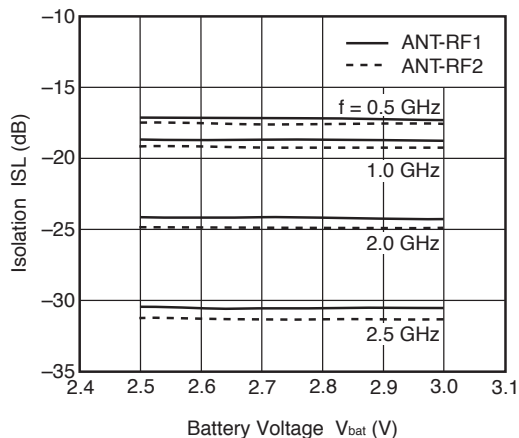

INSERTION LOSS vs. INPUT POWER

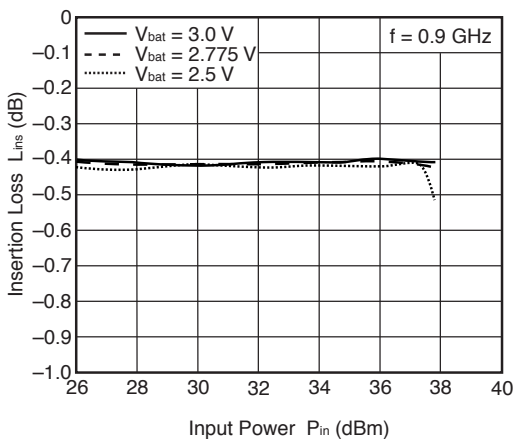

2ND HARMONICS vs. INPUT POWER

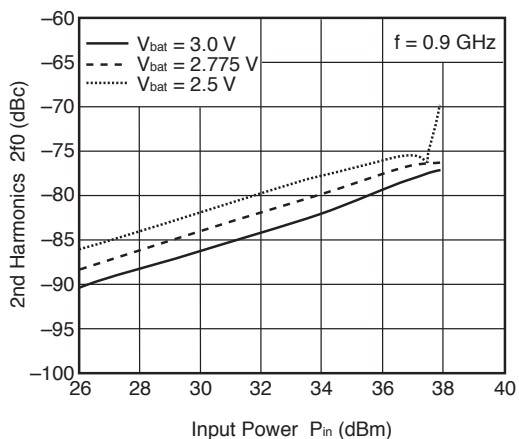

3RD HARMONICS vs. INPUT POWER

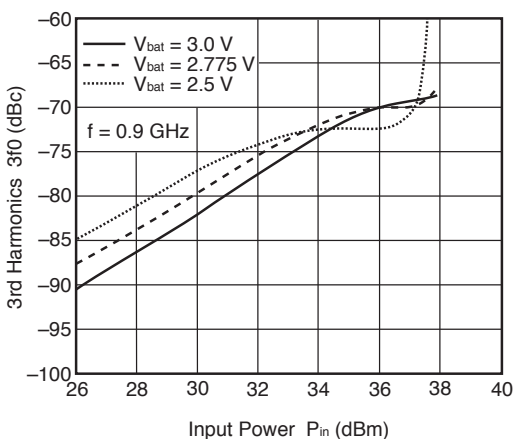

**Remark** The graphs indicate nominal characteristics.



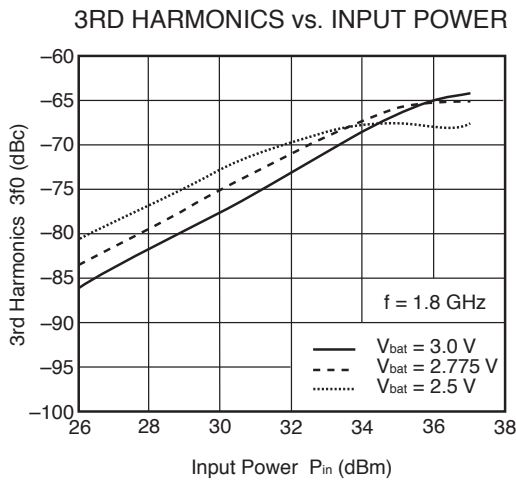
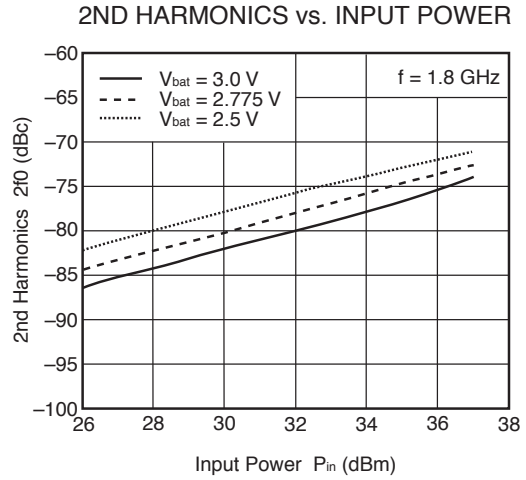
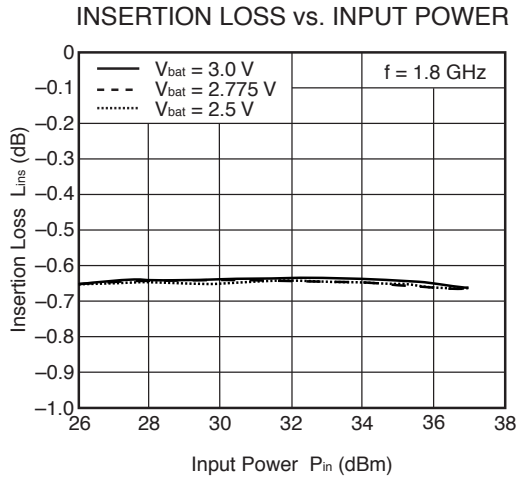

**Remark** The graphs indicate nominal characteristics.

**MOUNTING PAD LAYOUT DIMENSIONS**

**16-PIN PLASTIC QFN (T6C) (UNIT: mm)**

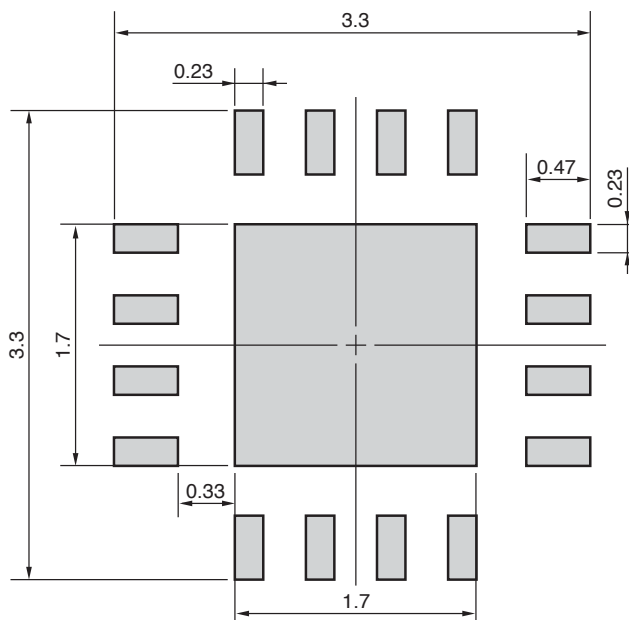

**Remark** The mounting pad layout in this document is for reference only.  
 When designing PCB, please consider workability of mounting, solder joint reliability, prevention of solder bridge and so on, in order to optimize the design.

**PACKAGE DIMENSIONS**

**16-PIN PLASTIC QFN (T6C) (UNIT: mm)**

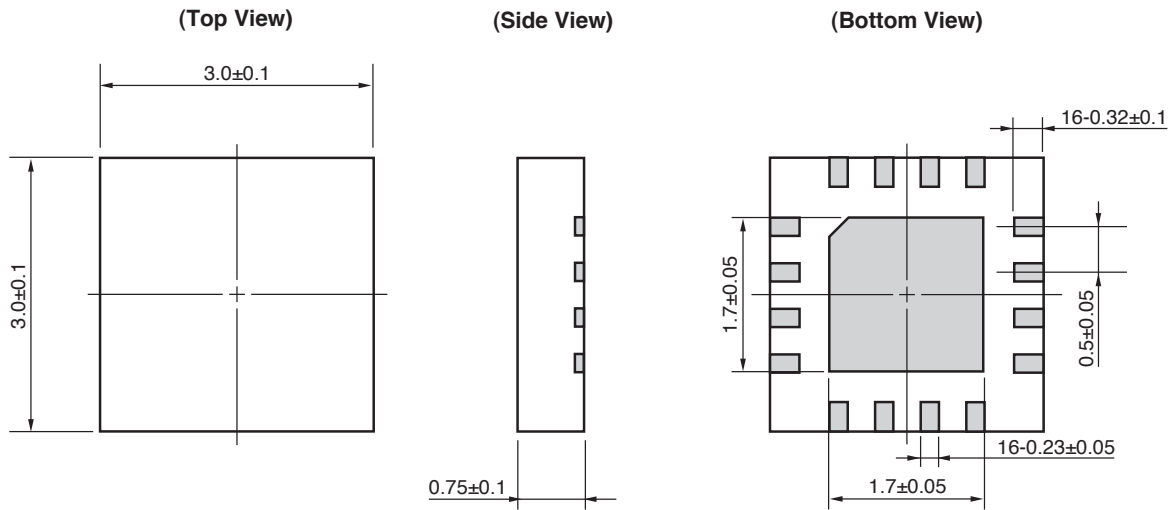

**RECOMMENDED SOLDERING CONDITIONS**

This product should be soldered and mounted under the following recommended conditions. For soldering methods and conditions other than those recommended below, contact your nearby sales office.

Soldering Method	Soldering Conditions	Condition Symbol
Infrared Reflow	Peak temperature (package surface temperature)	: 260°C or below
	Time at peak temperature	: 10 seconds or less
	Time at temperature of 220°C or higher	: 60 seconds or less
	Preheating time at 120 to 180°C	: 120±30 seconds
	Maximum number of reflow processes	: 3 times
	Maximum chlorine content of rosin flux (% mass)	: 0.2%(Wt.) or below
Partial Heating	Peak temperature (pin temperature)	: 350°C or below
	Soldering time (per side of device)	: 3 seconds or less
	Maximum chlorine content of rosin flux (% mass)	: 0.2%(Wt.) or below

**Caution Do not use different soldering methods together (except for partial heating).**

• **The information in this document is current as of May, 2009. The information is subject to change without notice. For actual design-in, refer to the latest publications of NEC Electronics data sheets, etc., for the most up-to-date specifications of NEC Electronics products. Not all products and/or types are available in every country. Please check with an NEC Electronics sales representative for availability and additional information.**

- No part of this document may be copied or reproduced in any form or by any means without the prior written consent of NEC Electronics. NEC Electronics assumes no responsibility for any errors that may appear in this document.
- NEC Electronics does not assume any liability for infringement of patents, copyrights or other intellectual property rights of third parties by or arising from the use of NEC Electronics products listed in this document or any other liability arising from the use of such products. No license, express, implied or otherwise, is granted under any patents, copyrights or other intellectual property rights of NEC Electronics or others.
- Descriptions of circuits, software and other related information in this document are provided for illustrative purposes in semiconductor product operation and application examples. The incorporation of these circuits, software and information in the design of a customer's equipment shall be done under the full responsibility of the customer. NEC Electronics assumes no responsibility for any losses incurred by customers or third parties arising from the use of these circuits, software and information.
- While NEC Electronics endeavors to enhance the quality and safety of NEC Electronics products, customers agree and acknowledge that the possibility of defects thereof cannot be eliminated entirely. In addition, NEC Electronics products are not taken measures to prevent radioactive rays in the product design. When customers use NEC Electronics products with their products, customers shall, on their own responsibility, incorporate sufficient safety measures such as redundancy, fire-containment and anti-failure features to their products in order to avoid risks of the damages to property (including public or social property) or injury (including death) to persons, as the result of defects of NEC Electronics products.
- NEC Electronics products are classified into the following three quality grades: "Standard", "Special" and "Specific".

The "Specific" quality grade applies only to NEC Electronics products developed based on a customer-designated "quality assurance program" for a specific application. The recommended applications of an NEC Electronics product depend on its quality grade, as indicated below. Customers must check the quality grade of each NEC Electronics product before using it in a particular application.

"Standard": Computers, office equipment, communications equipment, test and measurement equipment, audio and visual equipment, home electronic appliances, machine tools, personal electronic equipment and industrial robots.

"Special": Transportation equipment (automobiles, trains, ships, etc.), traffic control systems, anti-disaster systems, anti-crime systems, safety equipment and medical equipment (not specifically designed for life support).

"Specific": Aircraft, aerospace equipment, submersible repeaters, nuclear reactor control systems, life support systems and medical equipment for life support, etc.

The quality grade of NEC Electronics products is "Standard" unless otherwise expressly specified in NEC Electronics data sheets or data books, etc. If customers wish to use NEC Electronics products in applications not intended by NEC Electronics, they must contact an NEC Electronics sales representative in advance to determine NEC Electronics' willingness to support a given application.

(Note)

- (1) "NEC Electronics" as used in this statement means NEC Electronics Corporation and also includes its majority-owned subsidiaries.
- (2) "NEC Electronics products" means any product developed or manufactured by or for NEC Electronics (as defined above).

M8E0904E

<b>Caution</b>	GaAs Products	<p>This product uses gallium arsenide (GaAs). GaAs vapor and powder are hazardous to human health if inhaled or ingested, so please observe the following points.</p> <ul style="list-style-type: none"><li>• Follow related laws and ordinances when disposing of the product. If there are no applicable laws and/or ordinances, dispose of the product as recommended below.<ol style="list-style-type: none"><li>1. Commission a disposal company able to (with a license to) collect, transport and dispose of materials that contain arsenic and other such industrial waste materials.</li><li>2. Exclude the product from general industrial waste and household garbage, and ensure that the product is controlled (as industrial waste subject to special control) up until final disposal.</li></ol></li><li>• Do not burn, destroy, cut, crush, or chemically dissolve the product.</li><li>• Do not lick the product or in any way allow it to enter the mouth.</li></ul>
----------------	---------------	--