

## AM/FM car radio tuner IC with stereo decoder and intelligent selectivity system

### Features

- FM part
  - AGC generation by RF and IF detection
  - I/Q mixer for 1<sup>st</sup> IF 10.7 MHz with image rejection
  - Mixer for 2<sup>nd</sup> IF 450 kHz
  - Internal 450 kHz band pass filter with bandwidth control by ISS
  - Fully integrated FM demodulator with noise cancellation
- AM part
  - Wide and narrow AGC generation
  - Mixer for 1<sup>st</sup> IF 10.7 MHz, AM up conversion
  - Mixer for 2<sup>nd</sup> IF 450 kHz
  - Integrated AM-demodulator
  - AM IF noise blanking
- Stereo decoder
  - PLL with adjustment free, fully integrated VCO
  - Automatic pilot dependent MONO/STEREO switching
  - Programmable ROLL-OFF compensation
  - High cut and stereo blend-characteristics programmable
  - Dedicated RDS mute
  - Audio noise blanker
- Additional features
  - VCO for world tuning range

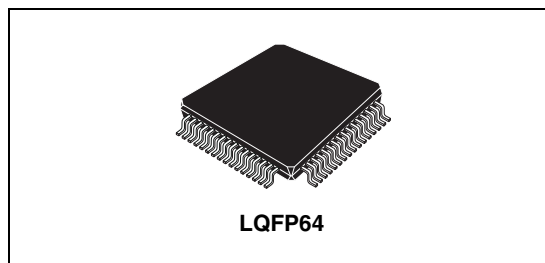

- High performance fast PLL for RDS-System
- IF counter for FM and AM with search stop signal
- Quality detector for level, deviation, adjacent channel and multipath
- ISS (Intelligent selectivity system) for cancellation of adjacent channel and noise influences
- Adjacent channel mute
- Fully electronic alignment
- Independent weather band input
- All functions I<sup>2</sup>C bus controlled

### Description

The TDA7541B is a high performance tuner circuit with stereo decoder for AM/FM car radio. It contains a mixer, IF amplifier, demodulator for AM and FM, stereo decoder, quality detection, ISS filter and PLL synthesizer with IF counter on a single chip. Use of BICMOS technology allows the implementation of several tuning functions and a minimum of external components.

**Table 1. Device summary**

Order code	Package	Packing
TDA7541B	LQFP64 (10 x 10 x 1.4 mm)	Tray
TDA7541BTR	LQFP64 (10 x 10 x 1.4 mm)	Tape and reel
TDA7541BW	LQFP64 (14 x 14 x 1.4 mm)	Tray
TDA7541BWTR	LQFP64 (14 x 14 x 1.4 mm)	Tape and reel

# Contents

<b>1</b>	<b>Block circuit diagram</b>	<b>6</b>
<b>2</b>	<b>Pin connection and pin description</b>	<b>7</b>
2.1	Pin connection	7
2.2	Pin description	8
<b>3</b>	<b>Electrical specifications and characteristics</b>	<b>10</b>
3.1	Thermal data	10
3.2	Absolute maximum ratings	10
3.3	Electrical characteristics	10
3.3.1	Globals	10
3.3.2	FM section	11
3.3.3	AM section	17
3.3.4	Stereo decoder section	19
3.3.5	PLL section	24
<b>4</b>	<b>Functional description</b>	<b>26</b>
4.1	FM part	26
4.1.1	Mixer 1 AGC and IF amplifier	26
4.1.2	Mixer2, limiter, FM demodulator and spike cancellation	26
4.1.3	Quality detection and ISS	26
4.1.4	Block diagram quality detection principle	29
4.1.5	Strong adjacent channel correction	30
4.1.6	Weak signal mute	30
4.1.7	Weather band input	31
4.2	AM section	31
4.2.1	Usage of control bit ADSEL (Addr23D7)	32
4.3	Stereo decoder	32
4.3.1	Decoder	32
4.3.2	Noise blanker	34
4.3.3	Functional description of the multipath detector	37
4.3.4	Quality detector	37
4.3.5	AFS control and stereo decoder mute	37
4.4	PLL and IF counter section	38

---

4.4.1	PLL frequency synthesizer block .....	38
4.4.2	IF counter block .....	39
4.5	I <sup>2</sup> C bus interface .....	39
<b>5</b>	<b>Software specification .....</b>	<b>42</b>
5.1	Chip address and overview .....	42
5.2	Address organization .....	43
5.3	Control register function .....	44
5.4	Data byte specification .....	47
<b>6</b>	<b>Appendix .....</b>	<b>68</b>
<b>7</b>	<b>Application circuit .....</b>	<b>74</b>
<b>8</b>	<b>Package information .....</b>	<b>75</b>
<b>9</b>	<b>Revision history .....</b>	<b>76</b>

## List of tables

Table 1.	Device summary . . . . .	1
Table 2.	Pin description . . . . .	8
Table 3.	Thermal data. . . . .	10
Table 4.	Absolute maximum ratings . . . . .	10
Table 5.	Globals . . . . .	10
Table 6.	FM section . . . . .	11
Table 7.	AM section . . . . .	17
Table 8.	Stereo decoder section. . . . .	19
Table 9.	PLL section. . . . .	24
Table 10.	ISS filter control by I <sup>2</sup> C bus. . . . .	28
Table 11.	Internal ISS control signals. . . . .	29
Table 12.	ISS control modes . . . . .	30
Table 13.	Usage of ADSEL. . . . .	32
Table 14.	Address organization . . . . .	43
Table 15.	I <sup>2</sup> C control bit description . . . . .	44
Table 16.	Subaddress description . . . . .	47
Table 17.	Addr 0 TPLL charge pump control (0Bh) . . . . .	47
Table 18.	Addr 1 TPLL Counter 1 (LSB). . . . .	48
Table 19.	Addr 2 TPLL Counter 2 (MSB) . . . . .	48
Table 20.	Addr 3 TV(00h) . . . . .	48
Table 21.	Addr 4 TV/IF Counter (FM ACh, AM 1Ch) . . . . .	49
Table 22.	Addr 5 TPLL Divider (FM 3Dh, AM 2Dh) . . . . .	50
Table 23.	Addr 6 AGC (FM 06h, AM 2Ah) . . . . .	51
Table 24.	Addr 7 Quality AC (FM 50h) . . . . .	52
Table 25.	Addr 8 Quality ACM/MP (FM 6Ah) . . . . .	53
Table 26.	Addr 9 Quality Dev (FM 49h) . . . . .	54
Table 27.	Addr 10 Quality MUX/FSU (FM 0Eh, AM 0Fh) . . . . .	55
Table 28.	Addr 11 Weak Signal Mute (FM A8h) . . . . .	55
Table 29.	Addr 12 AM IF NB (AM B1h) . . . . .	56
Table 30.	Addr 13 XTAL adjust(80h) . . . . .	56
Table 31.	Addr 14 IF2 adjust (FM E8h, AM 08h) . . . . .	57
Table 32.	Addr 15 IQ adjust / Switch (FM E7h) . . . . .	58
Table 33.	Addr 16 FM keying AGC (FM 1Dh) . . . . .	59
Table 34.	Addr 17 Roll off / Level gain (77h) . . . . .	60
Table 35.	Addr 18 SD Stereoblend / AM corner frequency (0Dh) . . . . .	61
Table 36.	Addr 19 SD High cut (2Fh) . . . . .	62
Table 37.	Addr 20 SD MP (FM 97h, AM 3Fh) . . . . .	63
Table 38.	Addr 21 SD Quality (FFM 7Ah, AM FAh) . . . . .	64
Table 39.	Addr 22 SD NB I (FM 05h, AM 04h) . . . . .	65
Table 40.	Addr 23 SD NB II (FM E2h, AM C2h) . . . . .	66
Table 41.	Addr 24, 26, 27, 28, 29 testing (FEh) . . . . .	67
Table 42.	Addr 25 Testing (FEh) . . . . .	67
Table 43.	Document revision history . . . . .	76

## List of figures

Figure 1.	Block circuit diagram . . . . .	6
Figure 2.	Pin connection (top view) . . . . .	7
Figure 3.	Programming of HC filter . . . . .	33
Figure 4.	Programming of stereo blend . . . . .	34
Figure 5.	Adaptive threshold control of noise blanker . . . . .	35
Figure 6.	Stereo blend controlled threshold adjust . . . . .	36
Figure 7.	Deviation controlled threshold adjust . . . . .	36
Figure 8.	Block diagram FM part . . . . .	68
Figure 9.	Block diagram VCO . . . . .	69
Figure 10.	Block diagram ISS function. . . . .	70
Figure 11.	Block diagram AM path. . . . .	71
Figure 12.	Block diagram stereo decoder . . . . .	72
Figure 13.	Block diagram audio noise blanker . . . . .	72
Figure 14.	Block diagram multi path detection for stereo decoder. . . . .	73
Figure 15.	Application circuit . . . . .	74
Figure 16.	LQFP64 mechanical data and package dimensions . . . . .	75

# 1 Block circuit diagram

Figure 1. Block circuit diagram

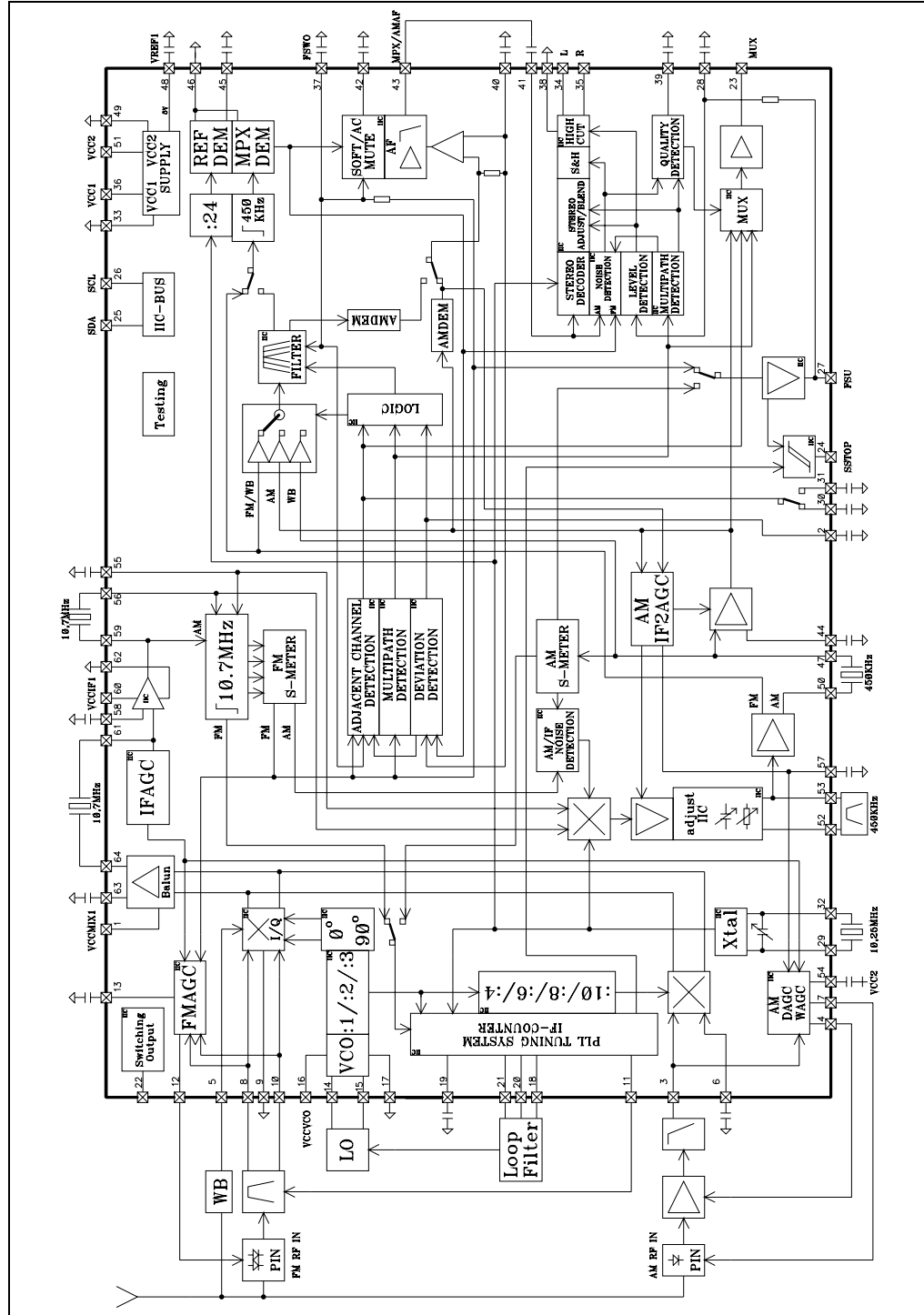

## 2 Pin connection and pin description

### 2.1 Pin connection

Figure 2. Pin connection (top view)

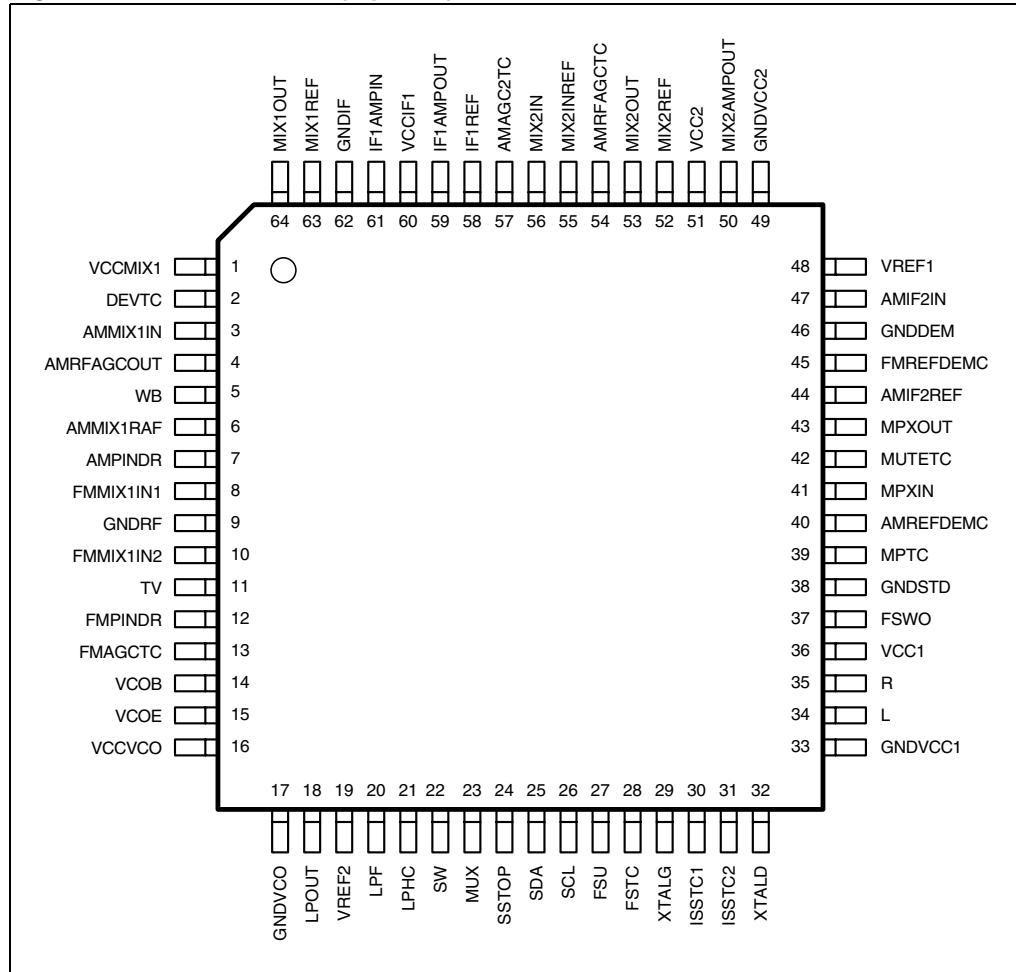

## 2.2 Pin description

**Table 2. Pin description**

Pin No.	Pin name	Function
1	VCCMIX1	Mixer1 Supply
2	DEVTC	Deviation Detector Time Constant
3	AMMIX1IN	AM Mixer1 Input
4	AMRFAGCOUT	AM RF AGC Voltage Output
5	WB	Weather Band Input
6	AMMIX1REF	AM Mixer1 Reference
7	AMPINDR	AM Pin Diode Driver Output
8	FMMIX1IN1	FM Mixer1 Input1
9	GNDRF	RF Ground
10	FMMIX1IN2	FM Mixer1 Input2
11	TV	Tuning Voltage Preselection
12	FMPINDR	FM Pin Diode Driver Output
13	FMAGCTC	FM AGC Time Constant
14	VCOB	VCO Input Base
15	VCOE	VCO Output Emitter
16	VCCVCO	VCO Supply
17	GNDVCO	VCO Ground
18	LPOUT	OpAmp Output to PLL Loop Filter
19	VREF2	Voltage Reference for PLL OpAmp
20	LPF	OpAmp Input to PLL Loop Filter
21	LPHC	High Current PLL Loop Filter Input
22	SW	Free Programmable Switch Output
23	MUX	Multiplexer Output
24	SSTOP	Search Stop Output
25	SDA	I <sup>2</sup> C Bus Data
26	SCL	I <sup>2</sup> C Bus Clock
27	FSU	Unweighted Field Strength Output
28	FSTC	S-meter Filtering Capacitor
29	XTALG	Xtal Oscillator to MOS Gate
30	ISSTC1	ISS Filter Time Constant1 (slow)
31	ISSTC2	ISS Filter Time Constant2 (fast)
32	XTALD	Xtal Oscillator to MOS Drain
33	GNDVCC1	Digital Ground



**Table 2. Pin description (continued)**

Pin No.	Pin name	Function
34	L	Stereo Decoder Output Left
35	R	Stereo Decoder Output Right
36	VCC1	Digital Supply
37	FSWO	Weighted Field Strength Output
38	GNDSTD	Stereo Decoder Ground
39	MPTC	Multipath Detector Time Constant
40	AMREFDEMC	AM Demodulator Reference
41	MPXIN	Stereo Decoder Input
42	MUTETC	Weak Signal Mute Time Constant
43	MPXOUT	AM Audio / MPX Output
44	AMIF2REF	AM IF2 Amplifier Reference Voltage
45	FMREFDEMC	FM Demodulator Reference
46	GNDDEM	FM Demodulator Ground
47	AMIF2IN	AM IF2 Amplifier Input
48	VREF1	5V Reference
49	GNDVCC2	Analog Ground
50	MIX2AMPOUT	MIXER2 Amplifier Output
51	VCC2	Analog Supply
52	MIX2REF	Mixer2 Reference
53	MIX2OUT	Mixer2 Output
54	AMRFAGCTC	AM RF AGC Time Constant
55	MIX2INREF	Mixer2 Input Reference
56	MIX2IN	Mixer2 Input
57	AMAGC2TC	AM AGC2 Time Constant
58	IF1REF	IF1 Amplifier Reference
59	IF1AMPOUT	IF1 Amplifier Output
60	VCCIF1	IF1 Supply
61	IF1AMPIN	IF1 Amplifier Input
62	GNDIF1	IF1 Ground
63	MIX1REF	Mixer1 Reference
64	MIX1OUT	Mixer1 Output

## 3 Electrical specifications and characteristics

### 3.1 Thermal data

Table 3. Thermal data

Symbol	Parameter	Value	Unit
$R_{TH(j-amb)}$	Thermal resistance junction-to-ambient	Max. 70	°C/W

### 3.2 Absolute maximum ratings

Table 4. Absolute maximum ratings

Symbol	Parameter	Conditions	Value	Unit
$V_S$	Supply voltage	-	9.5	V
$T_{amb}$	Ambient temperature	-	-40 to 85	°C
$T_{stg}$	Storage temperature	-	-55 to +150	°C
$V_{ESD}$	ESD withstand voltage	Human Body Model	2	kV
		Machine Model	100	V
		Charged Device Model	300	V

### 3.3 Electrical characteristics

#### 3.3.1 Globals

$T_{amb} = 25\text{ °C}$ ,  $V_{CC1} = V_{CC2} = V_{CCMIX1} = V_{CCVCO} = V_{CCIF} = 8.5\text{ V}$ ,  $f_{xtal} = 10.25\text{ MHz}$ , in application circuit, unless otherwise specified.

Table 5. Globals

Item	Symbol	Parameter	Test conditions	Min.	Typ.	Max.	Unit
<b>1. Supply</b>							
1.1	$V_{CC1}$	Digital supply voltage	-	7.7	8.5	9	V
1.2	$V_{CC2}$	Analog supply voltage	-	7.7	8.5	9	V
1.3	$V_{CCVCO}$	VCO supply voltage	-	7.7	8.5	9	V
1.4	$V_{CCMIX1}$	Mixer1 supply voltage	-	7.7	8.5	9	V
1.5	$V_{CCIF}$	IF1 Supply Voltage	-	7.7	8.5	9	V
1.6	$I_{CC1}$	Supply current	FM ON	-	19	23	mA
1.7	$I_{CC1}$	Supply current	AM ON	-	21	25	mA
1.8	$I_{CC2}$	Supply current	FM ON	-	48	58	mA
1.9	$I_{CC2}$	Supply current	AM ON	-	37	44	mA

Table 5. Globals (continued)

Item	Symbol	Parameter	Test conditions	Min.	Typ.	Max.	Unit
1.10	I <sub>CCVCO</sub>	Supply current	-	-	12	15	mA
1.11	I <sub>CCMIX1</sub>	Supply current	FM ON	-	32	40	mA
1.12	I <sub>CCMIX1</sub>	Supply current	AM ON	-	20	24	mA
1.13	I <sub>CCIF</sub>	Supply current	-	-	4	5	mA
<b>2. Reference voltages</b>							
2.1	V <sub>REF1</sub>	Internal reference voltage	I <sub>REF1</sub> = 0mA	4.8	5	5.2	V
2.2	V <sub>REF2</sub>	Internal reference voltage	I <sub>REF2</sub> = 0mA	2.4	2.5	2.6	V
<b>3. I<sup>2</sup>C bus interface</b>							
3.1	f <sub>SCL</sub>	Clock frequency	-	-	-	400	kHz
3.2	V <sub>IL</sub>	Input low voltage	-	-	-	1	V
3.3	V <sub>IH</sub>	Input high voltage	-	2	-	-	V
3.4	I <sub>IN</sub>	Input current	-	-5	-	5	μA
3.5	V <sub>O</sub>	Output acknowledge voltage	I <sub>O</sub> = 1.6mA	-	-	0.4	V

### 3.3.2 FM section

T<sub>amb</sub> = 25 °C, V<sub>CC1</sub> = V<sub>CC2</sub> = V<sub>CCMIX1</sub> = V<sub>CCVCO</sub> = V<sub>CCIF</sub> = 8.5 V, f<sub>Xtal</sub> = 10.25 MHz, f<sub>RF</sub> = 98 MHz, dev = 40 kHz, f<sub>Mod</sub> = 1 kHz, in application circuit, unless otherwise specified.

Table 6. FM section

Item	Symbol	Parameter	Test conditions	Min.	Typ.	Max.	Unit
<b>4. Wide band RF AGC</b>							
4.1	V <sub>8-10</sub>	Lower threshold start	V <sub>13</sub> = 2.5 V, RFK "0"	-	79	-	dBμV
4.2	V <sub>8-10</sub>	Upper threshold start	V <sub>13</sub> = 2.5 V, RFK "0"	-	93	-	dBμV
4.3	Δ V <sub>8-10</sub>	Control range RF KAGC	KAGC"000", RFAGC"00", V <sub>37</sub> = 3.0...3.7 V, RFK"1"	5	8	11	-
<b>5. Narrow band IF and keying AGC</b>							
5.1	V <sub>61</sub>	Lower threshold start	KAGC = off, V <sub>8-10</sub> = 0 mV <sub>RMS</sub>	-	82	-	dBμV
5.2	V <sub>61</sub>	Upper threshold start	KAGC = off, V <sub>8-10</sub> = 0 mV <sub>RMS</sub>	-	94	-	dBμV
5.3	V <sub>61</sub>	Max. IFAGC threshold with KAGC	KAGC"000", IFAGC"00", V <sub>37</sub> = 3.0 V	-	97	-	dBμV
5.4	V <sub>37</sub>	Start point KAGC	KAGC"000", IFAGC"00",	3.2	3.4	3.6	V
5.5	Δ V <sub>61</sub>	Control range IF KAGC	KAGC"000", IFAGC"00", V <sub>37</sub> = 3.2...3.9 V	12	15	18	dB
<b>6. AGC time constant output</b>							
6.1	V <sub>13</sub>	Max. AGC output voltage	V <sub>8-10</sub> = 0 mV <sub>RMS</sub>	-	-	V <sub>REF1</sub> +V <sub>BE</sub>	V

Table 6. FM section (continued)

Item	Symbol	Parameter	Test conditions	Min.	Typ.	Max.	Unit
6.2	$V_{13}$	Min. AGC output voltage	$V_{8-10} = 100 \text{ mV}_{\text{RMS}}$	-	-	0.5	V
6.3	$I_{13}$	Min. AGC charge current	$V_{8-10} = 0 \text{ mV}_{\text{RMS}}, V_{13} = 2.5 \text{ V}$	-33	-25	-17.5	$\mu\text{A}$
6.4	$I_{13}$	Max. AGC discharge current	$V_{8-10} = 100 \text{ mV}_{\text{RMS}}, V_{13} = 2.5 \text{ V}$	1.7	2.5	3.3	mA
<b>7. AGC PIN diode driver output</b>							
7.1	$I_{12}$	AGC OUT, current min.	$V_{8-10} = 0 \text{ mV}_{\text{RMS}}, V_{12} = 2.5 \text{ V}$	15	25	35	$\mu\text{A}$
7.2	$I_{12}$	AGC OUT, current max.	$V_{8-10} = 50 \text{ mV}_{\text{RMS}}, V_{12} = 2.5 \text{ V}$	-	-	-16	mA
<b>8. FM I/Q Mixer1 (10.7 MHz)</b>							
8.1	$R_{\text{IN}}$	Input resistance	Differential	8	10	12	k $\Omega$
8.2	$C_{\text{IN}}$	Input capacitance	Differential	-	4	-	pF
8.3	$R_{\text{OUT}}$	Output resistance	-	530	660	790	$\Omega$
8.4	$V_{8,11}$	Input DC bias	-	2.2	2.5	2.8	V
8.5	G	Gain	Unloaded	20	22	24	dB
8.6	$G_1$	Gain	With 330 $\Omega$ load	14	16	18	dB
8.7	INOISE	Equivalent input noise	-	-	3	-	nV/ $\sqrt{\text{Hz}}$
8.8	$\text{CP}_{1\text{dB}}$	1dB compression point	Referred to diff. mixer input	-	100	-	dB $\mu\text{V}$
8.9	IIP3	3 <sup>rd</sup> order intermodulation	-	-	119	-	dB $\mu\text{V}$
8.10	IQP	I/Q phase adjust	PH	-7	-	+8	DEG
8.11	IRR	Image rejection ratio	Ratio wanted/image	30	40	-	dB
8.12	IRR	Image rejection ratio	With phase adjust	40	46	-	dB
<b>9. WB I/Q Mixer1 (10.7 MHz)</b>							
9.1	$R_{\text{IN}}$	Input resistance	Single ended	1.7	2.5	3.3	k $\Omega$
9.2	$C_{\text{IN}}$	Input capacitance	Single ended	-	3	-	k $\Omega$
9.3	$R_{\text{OUT}}$	Output resistance	-	530	660	790	$\Omega$
9.4	$V_5$	Input dc bias	-	2	2.3	2.6	V
9.5	G	Gain	unloaded	24	26	28	dB
9.6	INOISE	Equivalent Input noise	Source impedance 400 $\Omega$	-	2.3	-	nV/ $\sqrt{\text{Hz}}$
9.7	IIP3	3 <sup>rd</sup> order intermodulation	-	-	113	-	dB $\mu\text{V}$
<b>10. IF1 amplifier (10.7 MHz)</b>							
10.1	$R_{\text{IN}}$	Input resistance	-	265	330	396	$\Omega$
10.2	$C_{\text{IN}}$	Input capacitance	-	-	2.5	-	pF
10.3	$V_{61}$	DC input voltage	-	-	$V_{\text{CCIF1}}/3$	-	V
10.4	$R_{\text{OUT}}$	Output resistance	-	265	330	396	$\Omega$
10.5	$C_{\text{OUT}}$	Output capacitance	-	-	2.5	-	pF

Table 6. FM section (continued)

Item	Symbol	Parameter	Test conditions	Min.	Typ.	Max.	Unit
10.6	$V_{59}$	DC output voltage	-	-	$V_{CCIF1}/2$	-	V
10.7	$G_{min}$	Min. gain	IFG	-	9	-	dB
10.8	$G_{max}$	Max. gain	IFG	-	21	-	dB
10.9	INOISE	Equivalent input noise voltage	$G_{max}$ , $R_{gen}=330\ \Omega$ , $R_L=330\ \Omega$ , noise of $R_{gen}$ not included	-	3.2	-	$nV/\sqrt{Hz}$
10.10	$CP_{1dB}$	1 dB compression point	referred to $330\ \Omega$ input, $G_{max}$	-	99	-	$dB\mu V$
10.11	IIP3	3 <sup>rd</sup> order Intermodulation	referred to $330\ \Omega$ input, $G_{max}$	-	130	-	$dB\mu V$
<b>11. Mixer2 (450kHz)</b>							
11.1	$R_{IN}$	Input resistance	Differential	240	300	360	$\Omega$
11.2	$C_{IN}$	Input capacitance	-	-	2.5	-	pF
11.3	$V_{55,56}$	DC input voltage	-	3.7	4	4.3	V
11.4	$R_{OUT}$	Output resistance	-	100	-	-	$k\Omega$
11.5	$C_{OUT}$	Output capacitance	-	-	2.5	-	pF
11.6	$V_{52,53}$	DC output voltage	-	3.7	4	4.3	V
11.7	$g_m$	Conversion transconductance	WB Mode; referred to MIX2OUT	-	126	-	$\mu A/V$
11.8	G	Gain	FM Mode, referred to MIX2OUT	-	16	-	dB
11.9	$C_{step}$	Min. cap. Step	IF2A	-	2.2	-	pF
11.10	$C_{max}$	Max. cap.	IF2A	-	33	-	pF
11.11	INOISE	Equivalent input noise voltage, including buffer mixer2	$R_{gen} = 330\ \Omega$ , IF2Q"10" noise of $R_{gen}$ not included	-	15	-	$nV/\sqrt{Hz}$
11.12	$CP_{1dB}$	1dB compression point	referred to $330\ \Omega$ input, IF2Q"10"	-	116	-	$dB\mu V$
11.13	IIP3	3 <sup>rd</sup> order Intermodulation	referred to $330\ \Omega$ input, IF2Q"10"	-	132	-	$dB\mu V$
<b>12. Demodulator, audio output</b>							
12.1	THD	Total harmonic distortion	Dev.= 75 kHz, $V_{56}= 100\ dB\mu V$ , IF2Q"11"	-	0.1	0.3	%
12.2	$a_{AM}$	AM suppression	$V_{56}=100\ dB\mu$ , $\Delta f = 40\ KHz$ , $f_{mod}=1\ kHz$ , $f_{mod}=1\ kHz@AM$ , $m =0.3\ %$	40	60	-	dB
12.3	$V_{MPX}$	MPX output signal	Dev.= 75 kHz	440	500	560	$mV_{RMS}$
12.4	$R_{OUT}$	Output impedance	-	20	40	60	$\Omega$
12.5	$R_{LOAD}$	Load resistance	-	10	-	-	$k\Omega$

Table 6. FM section (continued)

Item	Symbol	Parameter	Test conditions	Min.	Typ.	Max.	Unit
12.6	(S+N)/N	Signal plus noise-to-noise ratio at MPXOUT	$\Delta f = 40 \text{ kHz}$ , $f_{\text{mod}} = 1 \text{ kHz}$ , $V_{56} = 100 \text{ dB}\mu\text{V}$ , De-emphasis = $50 \mu\text{s}$ , $B = 200 \text{ Hz to } 15 \text{ kHz}$ ISSENA = 0	70	-	-	dB
12.7	(S+N)/N	Signal plus noise-to-noise ratio In weatherband mode	$\Delta f = 3.5 \text{ kHz}$ , $f_{\text{mod}} = 1 \text{ kHz}$ , $V_{56} = 100 \text{ dB}\mu\text{V}$ , De-emphasis = $75 \mu\text{s}$ , setting see <a href="#">Table 10</a>	40	-	-	dB
<b>13. Quality detection</b>							
<b>Unweighted field strength (FSU) and weighted field strength</b>							
13.1	$V_{37}$	DC output voltage	$V_{56} = 20 \text{ dB}\mu\text{V}$ , FMON=1, FSWO = OFF	-	2.5	-	V
13.2	$V_{37}$	DC output voltage	$V_{56} = 50 \text{ dB}\mu\text{V}$ , FMON=1, FSWO = OFF	-	3	-	V
13.3	$V_{37}$	DC output voltage	$V_{56} = 70 \text{ dB}\mu\text{V}$ , FMON=1, FSWO = OFF	-	3.5	-	V
13.4	$V_{37}$	DC output voltage	$V_{56} > 120 \text{ dB}\mu\text{V}$ , FMON=1, FSWO = OFF	-	4.6	-	V
13.5	$\Delta V_{37}$	Slope	-	-	25	-	mV/dB
13.6	$\Delta V_{37}$	DC offset	-	-200	-	0	mV
13.7	$R_{\text{OUT}}$	Output impedance	FSWO	17	23.5	30	k $\Omega$
13.8	$V_{27}$	DC output voltage	$V_{56} = 20 \text{ dB}\mu\text{V}$ , FMON=1, SL="101"	-	0.1	0.4	V
13.9	$V_{27}$	DC output voltage	$V_{56} = 50 \text{ dB}\mu\text{V}$ , FMON=1, SL="101"	-	1	-	V
13.10	$V_{27}$	DC output voltage	$V_{56} = 70 \text{ dB}\mu\text{V}$ , FMON=1, SL="101"	-	2	-	V
13.11	$V_{27}$	DC output voltage	$V_{56} > 120 \text{ dB}\mu\text{V}$ , FMON=1, SL="101"	4	-	-	V
13.12	$\Delta V_{27}$	Slope	-	-	50	-	mV/dB
13.13	$R_{\text{OUT}}$	Output impedance	FSU	320	400	480	$\Omega$
13.14	$R_{\text{load}}$	Load resistor	FSU	-	20	-	k $\Omega$
13.15	$V_{27}$	DC output voltage AM	$V_{47} = 20 \text{ dB}\mu\text{V}$ , FMON = 0, SL= "010"	-	0.1	0.3	V
13.16	$V_{27}$	DC output voltage AM	$V_{47} = 40 \text{ dB}\mu\text{V}$ , FMON = 0, SL= "010"	-	1.25	-	V
13.17	$V_{27}$	DC output voltage AM	$V_{47} = 60 \text{ dB}\mu\text{V}$ , FMON = 0, SL= "010"	-	3.0	-	V
13.18	$V_{27}$	DC output voltage AM	$V_{47} > 100 \text{ dB}\mu\text{V}$ , FMON = 0, SL= "010"	4.5	-	-	V

Table 6. FM section (continued)

Item	Symbol	Parameter	Test conditions	Min.	Typ.	Max.	Unit
13.19	$\Delta V_{27}$	Slope AM	FMON=0	-	90	-	mV/dB
13.20	$f_{LP}$	-3 dB frequency low pass AM	FMON=0	-	40	-	kHz
<b>Adjacent channel gain</b>							
13.21	$G_{AC}$	Gain	-	-	32	-	dB
<b>Adjacent channel filter</b>							
13.22	$f_{HP}$	-3 dB frequency highpass	ACF=0	-	100	-	kHz
13.23	$f_{-20dB}$	Attenuation 20dB	-	-	70	-	kHz
13.24	$f_{BP}$	Centre frequency	ACF=1	-	100	-	kHz
<b>Multipath channel gain</b>							
13.25	$G_{MP}$	Gain	-	-	12	-	dB
<b>Multipath bandpass filter</b>							
13.26	$f_C$	Centre frequency	-	-	19	-	kHz
13.27	Q	Quality factor	-	5	8	10	-
<b>14. ISS (intelligent selectivity system) filter 450kHz</b>							
14.1	$f_{centre}$	Centre frequency	$f_{REF\_intern} = 450kHz$		450		kHz
14.2	BW 3dB	Bandwidth, -3 dB	ISSBW = 1	70	80	90	kHz
14.3	BW 20dB	Bandwidth, -20 dB	ISSBW = 1	132	150	168	kHz
14.4	BW 3dB	Bandwidth, -3 dB	ISSBW = 0	106	120	135	kHz
14.5	BW 20dB	Bandwidth, -20 dB	ISSBW = 0	220	250	280	kHz
14.6	BW 3dB	Bandwidth weather band	WBON = 1	18	22	26	kHz
14.7	BW 20dB	-20dB weather band	WBON = 1	-	70	-	kHz
<b>Adjacent channel ISS filter threshold</b>							
14.8	$V_{THAC}$	Internal low threshold	ACTH	-	2.75	-	V
14.9	$V_{THAC}$	Internal high threshold	ACTH	-	3.05	-	V
<b>Multipath threshold</b>							
14.10	$V_{THMP}$	Internal low threshold	MPTH	-	0.50	-	V
14.11	$V_{THMP}$	Internal high threshold	MPTH	-	1.25	-	V
<b>ISS filter time constant</b>							
14.12	$I_{30,31}$	Charge current low mid	TISS, BWDEF = 1	-89	-74	-59	$\mu A$
14.13	$I_{30,31}$	Charge current high mid	TISS, BWDEF = 1	-72	-60	-48	$\mu A$
14.14	$I_{30,31}$	Charge current low narrow	TISS, BWDEF = 1	-148	-124	-99	$\mu A$
14.15	$I_{30,31}$	Charge current high narrow	TISS, BWDEF = 1	-132	-110	-88	$\mu A$
14.16	$I_{30,31}$	Discharge current low	TISS, BWDEF = 0	0.5	1	1.5	$\mu A$

Table 6. FM section (continued)

Item	Symbol	Parameter	Test conditions	Min.	Typ.	Max.	Unit
14.17	$I_{30,31}$	Discharge current high	TISS, BWDEF = 0	11	15	19	$\mu\text{A}$
14.18	$V_{30,31}$	Low voltage	BWDEF = 0	-	0.1	0.2	V
14.19	$V_{30,31}$	High voltage	BWDEF = 1	4.6	4.9	-	V
<b>ISS filter switch threshold</b>							
14.20	$V_{30,31}$	Threshold ISS on	BWDEF = 0	-	3	-	V
14.21	$V_{30,31}$	Threshold ISS off	BWDEF = 0	-	1	-	V
14.22	$V_{30,31}$	Threshold ISS narrow on	BWDEF = 0	-	4	-	V
14.23	$V_{30,31}$	Threshold ISS narrow off	BWDEF = 0	-	2	-	V
<b>Deviation detection</b>							
14.24	$I_3$	Charge current low	TDEV	-40	-32	-20	$\mu\text{A}$
14.25	$I_3$	Charge current high	TDEV	-48	-39	-30	$\mu\text{A}$
14.26	$I_3$	Discharge current low	TDEV	0.5	1	1.5	$\mu\text{A}$
14.27	$I_3$	Discharge current high	TDEV	5.5	8	10.5	$\mu\text{A}$
14.28	$DEV_{WTH}$	Internal low threshold	DWTH, $I_3 = 1 \mu\text{A}$	-	20	-	kHz
14.29	$DEV_{WTH}$	Internal high threshold	DWTH, $I_3 = 1 \mu\text{A}$	-	50	-	kHz
14.30	$RATIO_{min}$	Referred to threshold	DTH	-	1	-	
14.31	$RATIO_{max}$	Referred to threshold	DTH	-	1.5	-	
<b>15. Weak signal mute</b>							
15.1	$V_{37}$	Upper start point	WMTH = 0, WMD = 7, $V_{IN}=V_{56}$ , AF = -3 dB	-	2.9	-	V
15.2	$V_{37}$	Lower start point	WMTH = 7, WMD = 7, $V_{IN}=V_{56}$ , AF = -3 dB	-	2.7	-	V
15.3	$a_{WMD}$	Min. mute depth	WMD = 0, WMTH = 7, $V_{56}=\text{OFF}$	10	14	-	dB
15.4	$a_{WMD}$	Max. mute depth	WMD = 7, WMTH = 7, $V_{56}=\text{OFF}$	22	26	-	dB
15.5	$a_{MTHISS}$	Mute threshold below WMTH for ISS filter "ON"	WMD, WMTH, $V_{IN}=V_{56}$	-	1	-	dB
15.6	$V_{ACMTH}$	Internal AC mute threshold	ACMTH	40	-	260	mV
15.7	$a_{ACMD}$	AC mute depth	ACMD	3	-	8	dB
15.8	$I_{42}$	Charge current	-	-65	-47.5	-30	$\mu\text{A}$
15.9	$I_{42}$	Discharge current	-	1.5	2.5	4	$\mu\text{A}$
<b>16. Multiplexer output</b>							
16.1	$V_{23}$	Output voltage low	-	-	0.1	0.2	V
16.2	$V_{23}$	Output voltage high	-	4.6	4.9	-	V
16.3	$R_{OUT}$	Output resistance	-	200	250	300	$\Omega$
16.4	$R_{23load}$	Load resistor	-	20	-	-	k $\Omega$



### 3.3.3 AM section

$T_{amb} = 25\text{ °C}$ ,  $V_{CC1} = V_{CC2} = V_{CCMIX1} = V_{CCVCO} = V_{CCIF} = 8.5\text{ V}$ ,  $f_{Xtal} = 10.25\text{ MHz}$ ,  
 $f_{RF} = 1\text{ MHz}$ ,  $m = 30\%$ ,  $f_{mod} = 1\text{ kHz}$ , in application circuit, unless otherwise specified.

**Table 7. AM section**

Item	Symbol	Parameter	Test conditions	Min.	Typ.	Max.	Unit
<b>17. Global</b>							
17.1	$V_{ANT\_US}$	Usable sensitivity <sup>(1)</sup>	(S+N)/N = 26 dB	-	19	25	dB $\mu$ V
17.2	(S+N)/N	Signal to Noise Ratio	Ref.: $V_3 = 80\text{ dB}\mu\text{V}$	50	55	-	dB
17.3	$a_{IF}$	IF1 rejection	S/N = 26 dB, $m = 30\%$ , $f_{mod} = 1\text{ kHz}$	70	80	-	dB
17.4	$V_3$	Min. RF AGC threshold	RFAGC	-	92	-	dB $\mu$ V
17.5	$V_3$	Max. RF AGC threshold		-	104	-	dB $\mu$ V
17.6	$V_{61}$	Min. IF AGC threshold	IFAGC	-	78	-	dB $\mu$ V
17.7	$V_{61}$	Max. IF AGC threshold		-	102	-	dB $\mu$ V
17.8	$V_{56}$	Min. DAGC threshold	DAGC	-	86	-	dB $\mu$ V
17.9	$V_{56}$	Max. DAGC threshold		-	98	-	dB $\mu$ V
<b>18. AGC voltage driver output</b>							
18.1	$V_4$	Max. AGC output voltage	-	3.3	3.5	-	V
18.2	$V_4$	Min. AGC output voltage	-	-	-	0.5	V
18.3	$ I_{41} $	AGC current	$V_4 = 0\text{ V}$ , $V_{54} = 3.5\text{ V}$ , LNA*00"	-	340	-	$\mu$ A
<b>19. AGC PIN diode driver output</b>							
19.1	$I_7$	AGC driver current	-	-	-	-15	mA
<b>20. AM Mixer1 (10.7 MHz)</b>							
20.1	$R_{IN}$	Input resistance	differential	45	-	-	k $\Omega$
20.2	$C_{IN}$	Input capacitance	differential	-	2.5	-	pF
20.3	$R_{OUT}$	Output impedance	-	530	660	790	$\Omega$
20.4	$CP_{1dB}$	1dB compression point	referred to diff. mixer input	-	112	-	dB $\mu$ V
20.5	$V_{3,6}$	Input DC bias	-	0.3	0.4	0.55	V
20.6	IIP3	3 <sup>rd</sup> order intermodulation	-	-	132	-	dB $\mu$ V
20.7	INOISE	Equivalent input noise	-	-	5.5	-	nV/ $\sqrt{\text{Hz}}$
20.8	G	Gain	With 330 $\Omega$ filter	3	5.5	7	dB
<b>21. AM mixer2</b>							
21.1	$R_{IN}$	Input resistance	-	240	300	360	$\Omega$
21.2	$C_{IN}$	Input capacitance	-	-	2.5	-	pF
21.3	$V_{55.56}$	DC input voltage	-	3.8	4	4.2	V
21.4	$R_{OUT}$	Output resistance	-	100	-	-	k $\Omega$

Table 7. AM section (continued)

Item	Symbol	Parameter	Test conditions	Min.	Typ.	Max.	Unit
21.5	$C_{OUT}$	Output capacitance	-	-	2.5	-	pF
21.6	$V_{52,53}$	DC output voltage	-	3.7	4.0	4.3	V
21.7	$g_m$	Conversion transconductance	MIX2OUT	-	440	-	$\mu A/V$
21.8	$G_{max}$	Max. gain	$L = 560 \mu H, Q = 28; C = 180 pF,$ referred to MIX2OUT	-	26	-	dB
21.9	$\Delta G$	Gain control range	-	-	20	-	dB
21.10	$C_{step}$	Min. cap. Step	IF2A	-	2.2	-	pF
21.11	$C_{max}$	Max. cap.	IF2A	-	33	-	pF
21.12	INOISE	Equivalent input noise voltage, including buffer mixer2	$A_{max}, R_{gen} = 330 \Omega, R_L = 2 k\Omega,$ noise of $R_{gen}$ not included	-	11	-	$nV/\sqrt{Hz}$
21.13	$CP_{1dB}$	1dB compression point	$A_{max},$ referred to $330 \Omega$ input	-	114	-	$dB\mu V$
21.14	IIP3	3 <sup>rd</sup> order Intermodulation	$A_{max},$ referred to $330 \Omega$ input	-	132	-	$dB\mu V$
<b>22. Buffer AM mixer2</b>							
22.1	$R_{OUT}$	Output resistance	-	1.6	2	2.4	$k\Omega$
22.2	$C_{OUT}$	Output capacitance	-	-	2.5	-	pF
22.3	$V_{50}$	DC output voltage	-	3.7	4.0	4.3	V
22.4	G	gain	$R_L = 2 k\Omega$	-8	-6	-4	dB
<b>23. AM IF2 amplifier</b>							
23.1	$R_{IN}$	Input resistance	-	1.6	2	2.4	$k\Omega$
23.2	$C_{IN}$	Input capacitance	-	-	2.5	-	pF
23.3	$V_{44,47}$	DC input voltage	-	4.1	4.3	4.5	V
23.4	$G_{max}$	Max. gain	-	49	52	55	dB
23.5	$\Delta G$	Gain control range	-	36	38	40	dB
23.6	INOISE	Equivalent input noise voltage	$G_{max}, R_{gen} = 2 k\Omega,$ noise of $R_{gen}$ not included	-	9.5	-	$nV/\sqrt{Hz}$
23.7	$CP_{1dB}$	1 dB compression point	$G_{max},$ referred to $2 k\Omega$ input	-	74	-	$dB\mu V$
23.8	IIP3	3 <sup>rd</sup> order Intermodulation	$G_{max},$ referred to $2 k\Omega$ input	-	100	-	$dB\mu V$
23.9	$V_{23}$	IF2 output voltage	$V_{56} = 90 dBV, m = off$	140	190	240	$mV_{RMS}$
<b>24. AMAGC2</b>							
24.1	$V_{AGC(start)}$	AGC start voltage (PIN47)	Input carrier voltage	-	62	-	$dB\mu V$
24.2	$\Delta AGC$	AGC2 range	Between start of AGC2 and the intervention point of prestage AGC	50	55	-	dB
24.3	$g_{AGC}$	Control slope	Seek mode	-	50	-	$\mu A/V$

Table 7. AM section (continued)

Item	Symbol	Parameter	Test conditions	Min.	Typ.	Max.	Unit
24.4	$g_{AGC}$	Control slope	normal mode	-	5	-	$\mu A/V$
24.5	$I_{57I}$	Max. AGC charge current	Seek mode	-	125	-	$\mu A$
24.6	$I_{57I}$	Max. AGC charge current	normal mode	-	5	-	$\mu A$
24.7	$V_{57}$	Max. AGC output voltage	$V_{47} = 100 \text{ dB}\mu$	4.6	4.8	-	V
24.8	$V_{57}$	Min. AGC output voltage	$V_{47} = 20 \text{ dB}\mu$	-	0.2	0.5	V
<b>25. AM audio output</b>							
25.1	$V_{43}$	Audio output voltage	$V_{56} = 90 \text{ dB}\mu$ , $m = 30 \%$ , $f_{mod} = 1 \text{ KHz}$	170	200	230	$mV_{RMS}$
25.2	THD	Total harmonic distortion	$V_{56} = 90 \text{ dB}\mu$ , $m = 30 \%$ , $f_{mod} = 1 \text{ kHz}$	-	0.3	0.5	%
25.3			$V_{56} = 90 \text{ dB}\mu$ , $m = 80\%$ , $f_{mod} = 1 \text{ kHz}$	-	0.5	0.9	
25.4	$R_{OUT}$	Output impedance	-	20	25	30	$\Omega$
<b>26. IF noise blanking</b>							
26.1	$t_{bl}$	Min. blanking time	-	-	8	-	$\mu s$
26.2	$t_{bl}$	Max. blanking time	-	-	17	-	$\mu s$
26.3	$V_{th}$	Min internal threshold	-	-	50	-	mV
26.4	$V_{th}$	Max. internal threshold	-	-	187.5	-	mV
26.5	$V_{thstep}$	Threshold step	-	-	12.5	-	mV

1. Can be reached in application circuit, not measured.

### 3.3.4 Stereo decoder section

$T_{amb} = 25 \text{ }^\circ\text{C}$ ,  $V_{CC1} = V_{CC2} = V_{CCMIX1} = V_{CCVCO} = V_{CCIF} = 8.5 \text{ V}$ ,  $f_{Xtal} = 10.25 \text{ MHz}$ ,  
 $V_{MPX} = 500 \text{ mV}_{rms}$  mono,  $f = 1 \text{ kHz}$ , de-emphasis  $\tau = 50 \mu s$ , in application circuit, unless otherwise specified.

Table 8. Stereo decoder section

Item	Symbol	Parameter	Test conditions	Min.	Typ.	Max.	Unit
<b>27. Stereo decoder</b>							
27.1	$V_{in}$	MPX input level	-	-	0.5	0.93	$V_{rms}$
27.2			WBON = 1	-	0.05	0.06	
27.3	$R_{in}$	Input resistance	-	80	100	120	$k\Omega$
27.4	$G_{STD}$	Stereo decoder gain	-	2	2.5	3	dB
27.5	$G_{STDWB}$	Stereo decoder gain	Weather band mode	23	26	27	dB
27.6	SVRR	Supply voltage ripple rejection	$V_{ripple} = 100 \text{ mV}$ , $f = 1 \text{ kHz}$	-	60	-	dB

Table 8. Stereo decoder section (continued)

Item	Symbol	Parameter	Test conditions	Min.	Typ.	Max.	Unit
27.7	A	channel separation	$V_{MPX} = 500 \text{ mV}_{\text{rms}}$ stereo, only L/R, ROC adjusted	35	40	-	dB
27.8	THD	Total harmonic distortion	-	-	0.02	0.3	%
27.9	(S+N)/N	Signal plus noise to noise ratio	A-weighted, 19 kHz notch	-	85	-	dB
<b>28. Mono/stereo switch</b>							
28.1	$V_{PTHST1}$	Pilot threshold voltage	for Stereo, PTH = 1	5	8	12	$\text{mV}_{\text{rms}}$
28.2	$V_{PTHST0}$	Pilot threshold voltage	for Stereo, PTH = 0	7	11	16	$\text{mV}_{\text{rms}}$
28.3	$V_{PTHMO1}$	Pilot threshold voltage	for Mono, PTH = 1	3.5	6	10	$\text{mV}_{\text{rms}}$
28.4	$V_{PTHMO0}$	Pilot threshold voltage	for Mono, PTH = 0	6	9	14	$\text{mV}_{\text{rms}}$
<b>29. 19kHz PLL</b>							
29.1	$f_{\text{lock}}$	Capture range	Pilot magnitude $20 \text{ mV}_{\text{rms}} = 4 \%$	18.9	-	19.1	kHz
29.2	DP	Pilot deviation range	$f_{\text{pilot}} = 19 \text{ kHz}$	4	-	30	%
<b>30. De-emphasis and high cut</b>							
30.1	$t_{\text{HC50}}$	De-emphasis time constant	DEEMP=0, High Cut OFF	45	50	55	$\mu\text{s}$
30.2	$t_{\text{HC75}}$	De-emphasis time constant	DEEMP = 1, High Cut OFF	67	75	83	$\mu\text{s}$
30.3	$t_{\text{HC50}}$	High cut time constant	DEEMP = 0, High Cut ON, $V_{28}=0.1\text{V}$	135	150	165	$\mu\text{s}$
30.4	$t_{\text{HC75}}$	High cut time constant	DEEMP = 1, High Cut ON, $V_{28} = 0.1 \text{ V}$	200	225	250	$\mu\text{s}$
30.5	$A_{\text{Amin}}$	Min. Attenuation in AM	$V_{\text{outmax}}/V_{\text{out}}@ f = 3.5 \text{ kHz}$ , DEEMP = 0, AMCF "111"	-	3.6	-	dB
30.6	$A_{\text{Amax}}$	Max. Attenuation in AM	$V_{\text{outmax}}/V_{\text{out}}@ f = 3.5 \text{ kHz}$ , DEEMP= 0, AMCF "000"	-	8	-	dB
<b>31. Stereo blend and high cut control</b>							
31.1	$LG_{\text{min}}$	Min. level gain	LG	-0.3	0	0.3	dB
31.2	$LG_{\text{max}}$	Max. level gain	LG	7.75	8.25	8.75	dB
31.3	$LG_{\text{step}}$	Level gain step Resolution	-	0.25	0.55	0.85	dB
31.4	$VSBL_{\text{min}}$	Min. voltage for mono	SBC	24	29	34	$\%V_{\text{REF1}}$
31.5	$VSBL_{\text{max}}$	Max. voltage for mono	SBC	53	58	63	$\%V_{\text{REF1}}$
31.6	$VSBL_{\text{step}}$	Step resolution	SBC	3.5	4.2	5	$\%V_{\text{REF1}}$
31.7	$VHCH_{\text{min}}$	Min. voltage for no high cut	HCHT	37	42	47	$\%V_{\text{REF1}}$
31.8	$VHCH_{\text{max}}$	Max.voltage for no high cut	HCHT	61	66	71	$\%V_{\text{REF1}}$

Table 8. Stereo decoder section (continued)

Item	Symbol	Parameter	Test conditions	Min.	Typ.	Max.	Unit
31.9	VHCH <sub>step</sub>	Step resolution	HCHT	7	8	9	%V <sub>REF1</sub>
31.10	VHCL <sub>min</sub>	Min. voltage for full high cut	HCLT	6	11	16	%VHCH
31.11	VHCL <sub>max</sub>	Max. voltage for full high cut	HCLT	28	33	38	%VHCH
31.12	VHCL <sub>step</sub>	Step resolution	HCLT	6.5	7.3	8.1	%VHCH
<b>32. Carrier and harmonic suppression at the output</b>							
32.1	a19	Pilot signal f = 19 kHz	-	45	50	-	dB
32.2	a38	Subcarrier f = 38 kHz	-	-	75	-	dB
32.3	a57	Subcarrier f = 57 kHz	-	-	62	-	dB
32.4	a76	Subcarrier f = 76 kHz	-	-	90	-	dB
<b>33. Intermodulation <sup>(1)</sup></b>							
33.1	a2	f <sub>mod</sub> = 10 kHz, f <sub>spur</sub> = 1 kHz	-	-	65	-	dB
33.2	a3	f <sub>mod</sub> = 13 kHz, f <sub>spur</sub> = 1 kHz	-	-	75	-	dB
<b>34. Traffic radio <sup>(2)</sup></b>							
34.1	a57	Signal f = 57 kHz	-	65	70	-	dB
<b>35. SCA <sup>(3)</sup></b>							
35.1	a67	Signal f = 67 kHz	-	-	75	-	dB
<b>36. ACI – adjacent channel interference <sup>(4)</sup></b>							
36.1	a114	Signal f = 114 kHz	-	-	95	-	dB
36.2	a190	Signal f = 190 kHz	-	-	84	-	dB
<b>37. FM noise blanker</b>							
37.1	V <sub>TRMIN</sub>	Min. trigger threshold <sup>(5)</sup>	V <sub>PEAK</sub> =0.8 V, NBLT "111"	-	147	-	mV <sub>OP</sub>
37.2	V <sub>TRMAX</sub>	Max. trigger threshold <sup>(5)</sup>	V <sub>PEAK</sub> =0.8 V, NBLT "000"	-	280	-	mV <sub>OP</sub>
37.3	V <sub>TRNOISE</sub>	Min. noise controlled trigger threshold	V <sub>PEAK</sub> = 1.5 V, NBCT "11"	-	450	-	mV <sub>OP</sub>
37.4	V <sub>TRNOISE</sub>	Max. noise controlled trigger threshold	V <sub>PEAK</sub> = 1.5 V, NBCT "00"	-	1200	-	mV <sub>OP</sub>
37.5	V <sub>PEAK</sub>	Peak voltage	NBRR "00", V <sub>MPX</sub> = 0 mV	-	0.8	-	V
37.6	V <sub>PEAK</sub>	Peak voltage	NBRR "00", V <sub>MPX</sub> = 50 mV, f = 150 kHz	-	1.9	-	V
37.7	V <sub>PEAK</sub>	Peak voltage	NBRR "00", V <sub>MPX</sub> = 200 mV, f = 150 kHz	-	3.5	-	V
37.8	V <sub>PEAKDEV</sub>	Min. deviation dependent peak voltage	V <sub>MPX</sub> = 500 mV, NBDC = 11 ("OFF")	-	0.8	-	V
37.9	V <sub>PEAKDEV</sub>	Max. deviation dependent peak voltage	V <sub>MPX</sub> = 500 mV, NBDC = 00	-	2.0	-	V

Table 8. Stereo decoder section (continued)

Item	Symbol	Parameter	Test conditions	Min.	Typ.	Max.	Unit
37.10	$V_{PEAKFS}$	Min. fieldstrength controlled peak voltage	$V_{MPX}=0mV$ , $V_{LEVEL} \ll V_{SBL}$ (fully mono), NBFC = 11 ("OFF")	-	0.8	-	V
37.11	$V_{PEAKFS}$	Max. fieldstrength controlled peak voltage	$V_{MPX}=0mV$ , $V_{LEVEL} \ll V_{SBL}$ (fully mono), NBFC = 00	-	2.0	-	V
37.12	$T_S$	Min. blanking time	Signal HOLDN in testmode, NBT = 00	-	38	-	$\mu s$
37.13	$T_S$	Max. blanking time	Signal HOLDN in testmode, NBT = 11	-	22	-	$\mu s$
37.14	$SR_{PEAK}$	Noise rectifier charge	Signal PEAK in testmode, NBPC = 0	-	5	-	mV/ $\mu s$
37.15	$SR_{PEAK}$	Noise rectifier charge	Signal PEAK in testmode, NBPC = 1	-	12	-	mV/ $\mu s$
37.16	$V_{RECTADJ}$	Noise rectifier discharge adjustment	Signal PEAK in testmode, NBRR = 00	-	0.3	-	V/ms
37.17	$V_{RECTADJ}$	Noise rectifier discharge adjustment	Signal PEAK in testmode, NBRR = 01	-	1.8	-	V/ms
37.18	$V_{RECTADJ}$	Noise rectifier discharge adjustment	Signal PEAK in testmode, NBRR = 10	-	2.8	-	V/ms
37.19	$V_{RECTADJ}$	Noise rectifier discharge adjustment	Signal PEAK in testmode, NBRR = 11	-	4	-	V/ms
37.20	$V_{ADJMP}$	Noise rectifier adjustment by multipath	Signal PEAK in testmode, $V_{MPTC}=1V$ , NBSMP = 0, NBMP = 1, NBRR = 01	-	3	-	V/ms
37.21	$V_{ADJMP}$	Noise rectifier adjustment by strong multipath influence	Signal PEAK in testmode, $V_{MPTC} = 1V$ , NBSMP = 1, NBMP = 0, NBRR = 01	-	4	-	V/ms
37.22	$V_{ADJMP}$	Noise rectifier adjustment by multipath and strong multipath influence	Signal PEAK in testmode, $V_{MPTC}=1V$ , NBSMP = 1, NBMP = 1, NBRR = 01	-	5.2	-	V/ms
<b>38. Multipath detector</b>							
38.1	$G_{MP}$	Min. multipath gain	MPG = 00	5	6	7	dB
38.2	$G_{MP}$	Max. multipath gain	MPG = 11	11	12	13	dB
38.3	$G_{RECTMP}$	Min. rectifier gain	MPRG = 01	-1	0	1	dB
38.4	$G_{RECTMP}$	Max. rectifier gain	MPRG = 11	5	7.6	9	dB
38.5	$I_{CHMP}$	Rectifier charge current	MPCC = 0	0.5	0.8	1.1	$\mu A$
38.6	$I_{CHMP}$	Rectifier charge current	MPCC = 1	0.2	0.4	0.7	$\mu A$
38.7	$I_{DISMP}$	Rectifier discharge current		0.5	1	-	mA
<b>39. Quality detector</b>							
39.1	a	Min. quality detector coefficient	QDC	0.5	0.6	0.7	-

Table 8. Stereo decoder section (continued)

Item	Symbol	Parameter	Test conditions	Min.	Typ.	Max.	Unit
39.2	a	Max. quality detector coefficient	QDC	0.9	1.05	1.2	-
39.3	b	Min. quality noise gain	QNG	5	6	7	dB
39.4	b	Max. quality noise gain	QNG	13	15	17	dB

## 1. Intermodulation suppression

$$a2 = \frac{V_o(\text{signal}, @ 1 \text{ kHz})}{V_o(\text{spurious}, @ 1 \text{ kHz})}; f_s = ((2 \times 10 \text{ kHz}) - 19 \text{ kHz})$$

$$a3 = \frac{V_o(\text{signal}, @ 1 \text{ kHz})}{V_o(\text{spurious}, @ 1 \text{ kHz})}; f_s = ((3 \times 13 \text{ kHz}) - 38 \text{ kHz})$$

measured with: 91 % stereo signal; 9 % pilot signal;  $f_m = 10 \text{ kHz}$  or  $13 \text{ kHz}$ .

## 2. Traffic radio (V.F.) suppression

$$a57(V,W,F) = \frac{V_o(\text{signal}, @ 1 \text{ kHz})}{V_o(\text{spurious}, @ 1 \text{ kHz}) \pm 23 \text{ kHz}}$$

measured with: 91% stereo signal; 9% pilot signal;  $f_m = 1 \text{ kHz}$ ; 5% sub carrier ( $f = 57 \text{ kHz}$ ,  $f_m = 23 \text{ Hz AM}$ ,  $m = 60 \%$ )

## 3. SCA (subsidiary communications authorization)

$$a67 = \frac{V_o(\text{signal}, @ 1 \text{ kHz})}{V_o(\text{spurious}, @ 9 \text{ kHz})}; f_s = ((2 \times 38 \text{ kHz}) - 67 \text{ kHz})$$

measured with: 81 % mono signal; 9 % pilot signal;  $f_m = 1 \text{ kHz}$ ; 10 % SCA - sub carrier ( $f_s = 67 \text{ kHz}$ , unmodulated)

## 4. ACI (adjacent channel interference)

$$a114 = \frac{V_o(\text{signal}, @ 1 \text{ kHz})}{V_o(\text{spurious}, @ 4 \text{ kHz})}; f_s = (110 \text{ kHz} - (2 \times 38 \text{ kHz}))$$

$$a190 = \frac{V_o(\text{signal}, @ 1 \text{ kHz})}{V_o(\text{spurious}, @ 4 \text{ kHz})}; f_s = (186 \text{ kHz} - (5 \times 38 \text{ kHz}))$$

measured with: 90 % mono signal; 9 % pilot signal;  $f_m = 1 \text{ kHz}$ ; 1% spurious signal ( $f_s = 110 \text{ kHz}$  or  $186 \text{ kHz}$ , unmodulated)

5. All thresholds are measured in test mode at the quality output. The thresholds are calculated by  $V_{NBTH} - V_{PEAK}$ .  $V_{PEAK}$  can be adjusted by applying a 150 kHz sinewave at MPXIN.

## 3.3.5 PLL section

$T_{amb} = 25\text{ }^{\circ}\text{C}$ ,  $V_{CC1} = V_{CC2} = V_{CCMIX1} = V_{CCVCO} = V_{CCIF} = 8.5\text{ V}$ ,  $f_{Xtal} = 10.25\text{ MHz}$ ,  
 $V_{MPX} = 500\text{ mV}_{rms}$  mono,  $f = 1\text{ kHz}$ , de-emphasis  $\tau = 50\text{ }\mu\text{s}$ , in application circuit, unless otherwise specified.

Table 9. PLL section

Item	Symbol	Parameter	Test conditions	Min.	Typ.	Max.	Unit
<b>40. Voltage controlled oscillator (VCO)</b>							
40.1	$f_{VCOmin}$	Min. VCO frequency	-	160	-	-	MHz
40.2	$f_{VCOmax}$	Max. VCO frequency	-	-	-	260	MHz
40.3	C/N	Carrier-to-noise-ratio	$f_{VCO} = 200\text{ MHz}$ , $\Delta f = 1\text{ kHz}$ , $B = 1\text{ Hz}$ , $Q_{loaded} = 60$	-	80	-	$\text{dBc}/\sqrt{\text{Hz}}$
<b>41. Crystal oscillator</b>							
41.1	$f_{xtal}$	Crystal frequency	-	-	10.25	-	MHz
41.2	C/N	Carrier-to-noise-ratio	$f_{xtal} = 10.25\text{ MHz}$ , $\Delta f = 10\text{ kHz}$	110	-	-	$\text{dBc}/\sqrt{\text{Hz}}$
41.3	$V_{29}$	Oscillator output voltage	-	-	400	-	$\text{mV}_{rms}$
41.4	$C_{29-32}$	Input capacitance	-	-	2.5	-	pF
41.5	$C_{step}$	Min. cap. Step	XTAL	-	0.75	-	pF
41.6	$C_{max}$	Max. cap.	XTAL	-	23.25	-	pF
41.7	$\Delta f/f$	Deviation versus $V_{CC}$	$\Delta V_{CC} = 1\text{ V}$	-	1.5	-	ppm/V
41.8	$\Delta f/f$	Deviation versus T	$-40\text{ }^{\circ}\text{C} < T < +85\text{ }^{\circ}\text{C}$	-	0.2	-	ppm/K
<b>42. Charge pump current</b>							
42.1	$-I_{20}$	Source current	$V_{20} = 2.5\text{ V}$	-	50	-	$\mu\text{A}$
42.2	$I_{20}$	Sink current		-	50	-	$\mu\text{A}$
42.3	$-I_{20}$	Source current	ICP, $V_{20} = 2.5\text{ V}$	-	550	-	$\mu\text{A}$
42.4	$I_{20}$	Sink current		-	500	-	$\mu\text{A}$
42.5	$-I_{20}$	Source current	ICP, $V_{20} = 2.5\text{ V}$	-	1	-	mA
42.6	$I_{20}$	Sink current		-	1	-	mA
42.7	$-I_{20}$	Source current		-	1.9	-	mA
42.8	$I_{20}$	Sink current		-	1.9	-	mA
<b>43. Loop filter input/output</b>							
43.1	$-I_{IN}$	Input leakage current	$V_{IN} = \text{GND}$ : $\text{PD}_{OUT} = \text{Tristate}$	-0.1	-	0.1	$\mu\text{A}$
43.2	$I_{IN}$	Input leakage current	$V_{IN} = \text{VREF1}$ $\text{PD}_{OUT} = \text{Tristate}$	-0.1	-	0.1	$\mu\text{A}$
43.3	$V_{OL}$	Output voltage Low	$I_{OUT} = -0.2\text{ mA}$	-	0.05	0.5	V
43.4	$V_{OH}$	Output voltage High	$I_{OUT} = 0.2\text{ mA}$	$V_{CCVCO}^-$ 0.5	$V_{CCVCO}^-$ 0.05	-	V
43.5	$I_{OUT}$	Output current, sink	$V_{OUT} = 1\text{ V}$ to $V_{CCVCO}^- - 1\text{ V}$	-	-	10	mA
43.6	$I_{OUT}$	Output current, source	$V_{OUT} = 1\text{ V}$ to $V_{CCVCO}^- - 1\text{ V}$	-10	-	-	mA



Table 9. PLL section (continued)

Item	Symbol	Parameter	Test conditions	Min.	Typ.	Max.	Unit
<b>44. Output of tuning voltage (TV)</b>							
44.1	$V_{OUT}$	Output voltage	-	0.5	-	$V_{VCO}-0.5$	V
44.2	$ V_{step} $	Min. voltage step	TVO	-	25	-	mV
44.3	$ V_{max} $	Max. voltage offset	TVO	-	3175	-	mV
44.4	$\Delta V$	Additional offset voltage	TVM=1, TVO+	-	3.175	-	V
44.5	$R_{OUT}$	Output impedance	TVM=0	-	40	-	k $\Omega$
44.6	$R_{OUT}$	Output impedance	TVM=1	-	20	-	k $\Omega$
<b>45. SSTOP output (open collector)</b>							
45.1	$V_{24}$	Output voltage low	$I_{24} = -200 \mu A$	-	0.2	0.5	V
45.2	$V_{24}$	Output voltage high	-	-	-	5	V
45.3	$-I_{24}$	Output leakage current	$V_{24} = 5 V$	-0.1	-	0.1	$\mu A$
45.4	$I_{24}$	Output current, sink	$V_{24} = 0.5 V$ to $5 V$	-	-	1	mA
45.5	$V_{37SSTH}$	Internal unfiltered field strength threshold for SSTOP=HIGH	SSTH, FMON=1	2.6	-	4.1	V
45.6	$V_{27SSTH}$	Internal unfiltered field strength threshold for SSTOP=HIGH	SSTH, FMON=0 SL = "011"	1.2	-	4.8	V
<b>46. Switch output</b>							
46.1	$V_{OL}$	Output Voltage low	SWM"1", SW"0", $I_{24} = -5 \mu A$	-	0.35	0.5	V
46.2	$V_{OH}$	Output Voltage high	SWM"1", SW"1"	-	$V_{CC}-1$	-	V
46.3	$-I_{22}$	Output leakage current	$V_{22}=5 V$	-0.5	-	0.5	$\mu A$
46.4	$I_{22}$	Output Current, sink	-	-	-	7	mA
46.5	$V_{OL}$	Output Voltage low	SWM"0", SW"0", $I_{22}=0 \mu A$	-	0.1	0.3	V
46.6	$V_{OH}$	Output Voltage high	SWM"0", SW"1", $I_{22}=1 mA$	-	$V_{CC}-1$	-	V
46.7	$I_{22}$	Output Current, sink	$V_{22}=5 V$	-7	-	-	mA

## 4 Functional description

### 4.1 FM part

#### 4.1.1 Mixer 1 AGC and IF amplifier

FM quadrature I/Q-mixer converts FM RF to IF1 of 10.7 MHz. The mixer provides inherent image rejection and wide dynamic range with low noise and large input signal performance. For accurate image rejection the phase-error of I/Q can be compensated by software (PH).

It is capable of tuning the US FM, US weather (dedicated WB input), Europe FM, Japan FM and East Europe FM bands:

- US FM = 87.9 to 107.9 MHz
- US weather = 162.4 to 162.55 MHz
- Europe FM = 87.5 to 108 MHz
- Japan FM = 76 to 91 MHz
- East Europe FM = 65.8 to 74 MHz

The AGC operates on different sensitivities and bandwidths in order to improve the input sensitivity and dynamic range. AGC thresholds are programmable by software (RFAGC, IFAGC, and KAGC). The output signal is a controlled current for pin diode attenuator.

A 10.7 MHz programmable amplifier (IFG) correct the IF ceramic insertion loss and the costumer level plan application.

#### 4.1.2 Mixer2, limiter, FM demodulator and spike cancellation

In the 2nd mixer stage the first 10.7 MHz IF is converted into the second 450 kHz IF.

The fully integrated sample and hold FM demodulator including spike cancellation (DSB) converts the IF signal from the 450 kHz limiter (limiter gain 80 dB typ.) to the FM multiplex output signal with very low distortion.

The sensitivity of spike blanking can be set via I<sup>2</sup>C bus.

#### 4.1.3 Quality detection and ISS

##### Field strength

Parallel to mixer2 input a 10.7 MHz limiter generates a signal for digital IF counter and field strength voltage  $V_{FSU_{int}}$ . This internal voltage  $V_{FSU_{int}}$  is used for AM IF noise blanker, adjacent channel and multi path detection and is available at PIN27 (FSU) in a range of 0 V to 5 V. The offset and slope of FSU signal can be adjusted via I<sup>2</sup>C bus (FSWO and SL) for application adaptation.

The voltage VFSWO including offset adjust is externally filtered at PIN37 (FSWO) and used for weak signal mute function and generation of ISS filter control signals in weak signal condition. It is possible to combine the IF counter result with this voltage VFSWO by programmable comparator threshold (SSTH).

### Adjacent channel detector

The input of the adjacent channel detector is AC coupled from VFSW. A programmable high-pass or band-pass (ACF) as well as rectifier generate a signal which is compared with adjustable threshold (ACTH). The output signals of this comparator is controlling the charge and discharge of the external capacitor at PIN30 or PIN31 (dependent on SEEK) with programmable discharge current (TISS). The level at PIN30/31 is used to generate the two digital signal ac and ac+ for ISS control. The adjacent channel information behind the rectifier is available as analog output signal at the multiplexer output (PIN23).

### Multipath detector

The input of the multi path detector is AC coupled from internal VFSW too. After filtering with 19 kHz band-pass and rectifying, this voltage is compared with an adjustable threshold (MPTH). The output signal of this comparator can be used to switch off the adjacent channel detection. This influence is selectable by I<sup>2</sup>C bus (MPENA).

The multi path information behind the rectifier is available as analog output signal at multiplexer output (PIN23).

### 450 kHz IF narrow band pass filter (ISS filter)

The device has an additional 450 kHz IF narrow band-pass filter for suppression of noise and adjacent channel signal influences. This narrow filter has three switchable bandwidths, narrow range of 80 kHz, mid range of 120 kHz and 22 kHz for weather band information. Without ISS (Intelligent Selectivity System) filter the IF bandwidth (wide range) is defined only by ceramic filter chain and mixer2 bandwidth. The filter is located between mixer2 output buffer and 450 kHz limiter stage. The centre frequency is matched to the demodulator centre frequency.

### Deviation detector

In order to avoid distortion in audio output signal the narrow ISS filter is switched OFF if over deviation is present. Hence the demodulator output signal is detected. After AC coupling, low-pass filtering and peak rectifying this signal is charging/discharging the external DEVTC capacitor by an IIC programmable charge/discharge current (TDEV). The voltage at DEVTC is compared with adjustable thresholds (DWITH, DTH) and generates two digital control signals (dev, dev+). For weak signal condition the deviation threshold depends on FSWO.

### ISS switch logic

All digital control signals coming from adjacent channel detector, deviation detector and weak signal mute are acting via switching matrix on ISS filter switch. IF2 narrow band-pass switch mode is controlled also by software (ISSENA, ISSON, WBON, ISSBW, and BWDEF). The switching of the IF band-pass is also possible to influence by external manipulation of DC voltage at PIN30.

The influence of the ISS software control on the functionality of the ISS filter is described in [Table 10](#). The value "X" for the control bit means the bit does not influence the filter control in this condition.

Table 10. ISS filter control by I<sup>2</sup>C bus

I <sup>2</sup> C control bits						Notes
ISSENA adr4/d2	ISSON adr11/d0	ISSBW adr7/d0	WBON adr11/d1	ISSM adr9/d7	BWDEF adr7/d1	
0	X	X	X	X	X	ISS filter is switched off (bypass)
1	1	0	X	X	X	ISS filter is in manual control mode, Band width is 120 kHz
1	1	1	X	X	X	ISS filter is in manual control mode, Band width is 80 kHz
1	1	X	1	X	X	ISS filter is in manual control mode, Band width is 22 kHz This setting must be used for weather band application
1	0	X	X	0	0	ISS filter is in automatic control mode Filter activation and band width defined by control table mode1
1	0	X	X	1	0	ISS filter is in automatic control mode Filter activation and band width defined by control table mode2
1	0	0	X	0	1	ISS filter is in automatic control mode Filter activation defined by control table mode1 band width fixed to 120 kHz
1	0	0	X	1	1	ISS filter is in automatic control mode Filter activation defined by control table mode2 band width fixed to 120 kHz
1	0	1	X	0	1	ISS filter is in automatic control mode Filter activation defined by control table mode1 band width fixed to 80 kHz
1	0	1	X	1	1	ISS filter is in automatic control mode Filter activation defined by control table mode2 band width fixed to 80 kHz

Description of I<sup>2</sup>C bits:

### ISSENA

ISS filter enable

“1”: ISS filter control enabled

“0”: ISS filter is switched off (bypass of the filter, wide)

### ISSON

ISS filter control mode

“1”: ISS filter is in manual control mode (switched "ON"); the bits ISSBW and WBON are defining the bandwidth

“0”: ISS filter is in automatic control mode according to mode1/2 table

### ISSBW

ISS filter band width

“1”: 80 kHz

“0”: 120 kHz

The bit has only influence if bit BWENA is “1”, or if bit ISSON is “1”

### WBON

Weather band enable

“1”: Weather band enable (FMmixer1 is disabled, Wbmixer1 enabled, stereo decoder gain 26dB, ISS filter bandwidth 22 kHz, IF2Q=“00”)

“0”: Weather band disable

For weather band enable it is need to set ISSON = “1”

### ISSM

ISS filter application mode

“0”: ISS filter application mode1

“1”: ISS filter application mode2

If BWENA is “1” the band width is always switched to ISSBW in case of ISS filter activated

### BWDEF

Enable bit ISSBW for ISS filter band with control

“1”: ISS filter is internally controlled, but band width is defined by bit ISSBW

“0”: ISS filter is internally controlled, band width is defined by mode1/2 table

For the internal control two application modes are available (ISSM). The conditions and settings are described in [Table 11](#) and [Table 12](#).

## 4.1.4 Block diagram quality detection principle

(without overdeviation correction)

**Table 11. Internal ISS control signals**

Signal	Low	High
Ac	No adjacent channel	Adjacent channel present
ac+	No strong adjacent channel	Adjacent channel higher as ac
Sm	Field strength higher as weak signal mute threshold	Field strength lower as weak signal mute threshold
Dev	Deviation lower as threshold DWTH	Deviation higher as threshold DWTH
dev+	Deviation lower as threshold DTH*DWTH	Deviation higher as threshold DTH*DWTH
Inton	ISS filter off by logic (wide)	ISS filter on by logic
int80	ISS filter 120 kHz (mid)	ISS filter 80 kHz (narrow)

Table 12. ISS control modes

Input signals					Mode1			Mode2		
ac	ac+	sm	dev	dev+	inton	int80	Function	inton	int80	Function
0	0	0	0	0	0	0	wide	0	0	wide
0	0	0	1	0	0	0	wide	0	0	wide
0	0	0	1	1	0	0	wide	0	0	wide
0	0	1	0	0	1	1	narrow	1	1	narrow
0	0	1	1	0	0	0	wide	1	0	mid
0	0	1	1	1	0	0	wide	0	0	wide
1	0	0	0	0	1	1	narrow	1	0	mid
1	1	0	0	0	1	1	narrow	1	1	narrow
1	0	0	1	0	1	0	mid	1	0	mid
1	1	0	1	1	1	0	mid	1	1	narrow

#### 4.1.5 Strong adjacent channel correction

Under strong adjacent channel it is possible to have disturbance of the audio signal created by interference between ISS filter control (deviation detection) and adjacent channel mute.

The control bits SACCE and SACCT can be used to avoid this disturbance. If the function is activated (SACCE = "1") the IF counter together with the internal field strength is used to suppress a malfunction of deviation detection. The bit SACCT is changing the sensitivity of the SACC block (SACCT = "1" means higher sensitivity).

*Figure 10* shows the ISS block diagram including the SACC function.

*Note:* The IF counter must be switched ON if this function is used (*Addr25D4* = "1")

#### 4.1.6 Weak signal mute

The filtered field strength signal (FSWO) is the reference for soft slope mute control in weak signal condition to eliminate audible effects. The start point and mute depth are programmable (WMTH, WMD) in a wide range. These settings together with FSWO bits are influencing the weak signal mute behavior. The time constant is defined by external capacitance at PIN 42. Additional adjacent channel mute function is supported. A high pass filter with -3 dB threshold frequency of 100 kHz, amplifier and peak rectifier generates an adjacent noise signal from Demodulator output. This value is compared with adjustable threshold (ACMTH). For present strong adjacent channel the MPX signal is additional attenuated (ACMD) and has the same time constant as weak signal mute.

### 4.1.7 Weather band input

If the weather band input is used the chip must be set in FM mode (FMON). In addition to that the ISS filter must be switched ON (ISSENA="1"), mixer2 quality factor must be set to IF2Q="00" and the ISS filter must be set in manual control mode (ISSON="1").

The bit WBON is:

- activating the WB input
- switching the ISS filter in WB mode (22 kHz band width)
- switching the stereo decoder InGain to 26 dB.

In order to increase the selectivity in weather band mode the AM 450kHz ceramic filter can be used in series to the ISS filter by activating ADSEL (please refer to [Figure 10](#), ISS block diagram and [Section 4.2.1](#), usage of bit ADSEL).

## 4.2 AM section

signals, narrow band information (DAGC) referred to PIN 56, up conversion signal (IFAGC) at PIN 61 and wide band information (RFAGC) at PIN 3. This gain control gives two output signals. The first one is a current for pin diode attenuator and the second one is a voltage for preamplifier. Time constant of RF and IF-AGC is defined by internal 100 k $\Omega$  resistor and external capacitor at PIN 54. The intervention points for AGC (DAGC, IFAGC and RFAGC) are programmable by software. The oscillator frequency for upconversion-mixer1 is generated by dividing the VCO frequency after VCO divider (VCOD) and AM pre-divider (AMD).

Two 10.7 MHz ceramic filters before mixer2 input increase 900 kHz attenuation.

The AMIF2 block contains mixer2, IF2 amplifier, demodulator and AGC2. The AM/FM mixer2 converts 10.7 MHz IF1 into 450 kHz IF2. Mixer2 output passes a 450 kHz narrow band filter (LC plus ceramic filter). LC centre frequency is adjustable by I<sup>2</sup>C bus (IF2A). The following IF2 amplifier provides signal for fully integrated demodulator. If the bit ADSEL is activated, the ISS filter is inserted between IF2 amplifier and demodulator in order to increase the selectivity (please refer to [Figure 11](#), AM path block diagram and [Section 4.2.1](#), usage of bit ADSEL).

Mixer2 and IF2 amplifier have a 2-stage AGC with careful take-over behavior to keep distortion low. The IF2 AGC range is about 55 dB.

The input signal of IF2 amplifier is used in limiter circuit for in-band level detection. The electrical characteristics are described in FM section.

The demodulator is a peak detector to generate the audio output signal.

At the MUX output the AMIF stereo is available.

### AM IF noise blanker

In order to remove in AM short spikes a noise cancellation conception is used in 450 kHz IF AM level. The advantage is to avoid long narrow AGC- and demodulator- time constants, which enlarge spike influences on audio signal and makes difficult to remove it in audio path.

The 10.7 MHz AM IF signal behind IF1 amplifier generates via limitation an unweighted field strength signal including slope of noise spike. The comparison of this detected slope between fast and slow rectifier ignores audio modulation whereby the threshold of slow

rectifier is programmable (AINBT). A comparator activates a pulse generator. The duration of this pulse is software programmable (AINT) and is smooth blanking out the spikes in mixer2.

### 4.2.1 Usage of control bit ADSEL (Addr23D7)

The control bit ADSEL can be used to increase the selectivity of the application in AM mode and WB mode. In FM it has no function. Table 12 shows the functionality of the control bit.

**Table 13. Usage of ADSEL**

FMON	WBON	ADSEL	Note
Addr4D7	Addr11D1	Addr23D7	
1	0	X	Standard FM mode
1	1	0	Weather band mode using 450 kHz ceramic filter; ISS filter must be manually switched on in order to limit the band width at 450 kHz IF (ISSENA/ISSON = "1"); 450 kHz ceramic filter is switched in series to ISS filter to increase selectivity
1	1	1	Standard weather band mode; ISS filter must be manually switched on in order to limit the band width at 450 kHz IF (ISSENA/ISSON = "1")
0	0	0	Standard AM mode
0	0	1	AM mode using ISS filter; ISS filter (22 kHz band width) is switched in series to the 450 kHz ceramic filter
0	1	X	Not allowed

## 4.3 Stereo decoder

### 4.3.1 Decoder

The stereo decoder-part of the TDA7541B contains all functions necessary to demodulate the MPX-signal, like pilot tone-dependent MONO/STEREO switching as well as the stereo blend and high cut.

Adaptations like programmable input gain, roll-off compensation, selectable de-emphasis time constant and a programmable field strength input allow easy adoption to different applications.

The 4<sup>th</sup> order input filter has a corner frequency of 80 kHz and is used to attenuate spikes and noise and acts as an anti-aliasing filter for the following switch capacitor filters.

#### Demodulator

In the demodulator block the left and the right channel are separated from the MPX-signal. In this stage also the 19 kHz pilot tone is canceled. For reaching a high channel separation the TDA7541B offers an I<sup>2</sup>C bus programmable roll-off adjustment, which is able to compensate the low pass behavior of the tuner section. Within the compensation range an adjustment to obtain about 40 dB channel separation is possible. The bits for this adjustment are located together with the level gain adjustment in one byte. This gives the



possibility to perform an optimization step during the production of the car radio where the channel separation and the field strength control are trimmed.

In addition to that the FM signal can be inverted.

### De-emphasis and high cut

The de-emphasis low pass allows to choose between a time constant of 50  $\mu$ s/75  $\mu$ s (DEEMP). The high cut control range will be in both cases  $T_{HC} = 2 \times T_{Deemp}$ . Inside the high cut control range (between VHCHT and VHCLT) the LEVEL signal is converted into a 5-bit word, which controls the low pass time constant between  $T_{Deemp} \dots 3 \times T_{Deemp}$ . Thereby the resolution will remain 5 bits referred to the voltage range between the VHCHT- and minimum VHCLT-values.

The high cut function can be switched off by I<sup>2</sup>C-bus.

**Figure 3. Programming of HC filter**

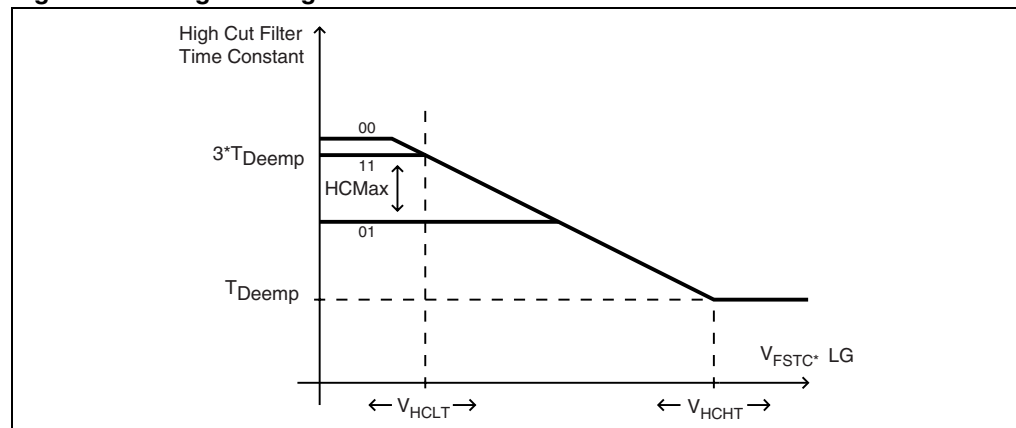

In AM mode (FMON = 0) the DEEMP bit together with the AM corner frequency bits (AMCF) can be used as programmable AM frequency response. The maximum corner frequency is defined by  $T_{Deemp}$ , the minimum is defined by  $3 \times T_{Deemp}$ . For the overall frequency response it is needed to take into account the frequency response of the AF output at MPXOUT and the Stereo decoder demodulator too.

### 19 kHz PLL and pilot tone detector

The PLL has the task to lock on the 19 kHz pilot tone during a stereo-transmission to allow a correct demodulation. The included pilot tone-detector enables the demodulation if the pilot tone reaches the selected pilot tone threshold VPTHST. Two different thresholds are available. The status of the detector output can be checked by reading the status byte of the TDA7541B via I<sup>2</sup>C bus or by reading the STEREO status at MUX pin23.

### Field strength control

The field strength input is used to control the high cut- and the stereo blend-function. In addition the signal can be also used to control the noise blanker thresholds and as input for the multipath detector.

### Level input and gain

As level input for the stereo decoder is used the FSU voltage (pin 27). Applying a capacitor at FSTC (pin28) a desired time constant can be reached together with the internal resistor of

10k between FSU pin and FSTC pin. The second stage is a programmable gain stage to adapt the VFSTC signal internally. The gain (LG) is widely programmable in 16 steps from 0 dB to 8.25 dB (step=0.55dB). These 4 bits are located together with the Roll-Off compensation bits in byte 14 to simplify a possible adaptation during the production of the car radio.

### Stereo blend control

The stereo blend control block converts the internal LEVEL-voltage into a demodulator compatible analog signal, which is used to control the channel separation between 0dB and the maximum separation. Internally this control range has a fixed upper limit, which is the internal reference voltage VREF1. The lower limit can be programmed between 29 and 58 % of VREF1 in 4 % steps. In order to adjust the external voltage VFSTC to the internal control range two values must be defined: the Level gain LG and VSBL. Full channel separation is reached when the internal level voltage (VST) becomes bigger than VREF1. Therefore the following equation can be used to estimate the gain:

$$LG = \frac{V_{REF1}}{V_{FSTC} @ \text{fullstereo}}$$

The MONO-voltage VMO (0dB channel separation) can be chosen selecting SBC.

**Figure 4. Programming of stereo blend**

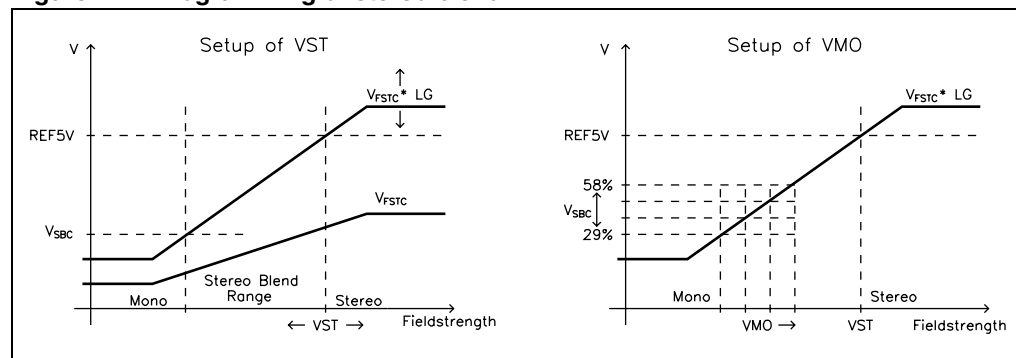

### High cut control

The high cut control set-up is similar to the stereo blend control set-up: the starting point VHCH can be set with 2 bits to be 42, 50, 58 or 66 % of VREF1 whereas the range can be set to be 11, 18.3, 25.7 or 33 % of VHCH.

### 4.3.2 Noise blanker

In the automotive environment spikes produced for example by the ignition or the wiper-motor disturb the MPX-signal. The aim of the noise blanker part is to cancel the audible influence of the spikes. Therefore the output of the stereo decoder is held at the actual voltage for a time between 22 ms and 38 ms (programmable).

In a first stage the spikes must be detected but to avoid a wrong triggering on high frequency (white) noise a complex trigger control is implemented. Behind the trigger stage a pulse former generates the "blanking"-pulse. An own biasing circuit supplies the noise blanker in order to avoid any cross talk to the signal path.

### Trigger path

The incoming FM demodulator output signal is taken in front of the weak signal mute, high pass filtered, amplified and rectified. This second order high pass filter has a corner-frequency of 140 kHz. The rectified signal,  $V_{RECT}$ , is low pass filtered to generate a signal called  $V_{PEAK}$ . Noise with a frequency above 140 kHz increases the  $V_{PEAK}$  voltage. The resulting voltage can be adjusted by use of the noise rectifier discharge current. The  $V_{PEAK}$  voltage is fed to a threshold generator, which adds to the  $V_{PEAK}$  voltage a DC threshold  $V_{TH}$ . Both signals,  $V_{RECT}$  and  $V_{PEAK}+V_{TH}$  are fed to a comparator, which triggers a re-triggerable monoflop. The output of the monoflop activates the sample-and-hold circuit in the signal path for the selected duration.

### Automatic noise controlled threshold adjustment

There are mainly two independent possibilities for programming the trigger threshold:

1. Low threshold in 8 steps (NBLT)
2. Noise adjusted threshold in 4 steps (NBCT).

The low threshold is active in combination with a good MPX signal without any noise; the  $V_{PEAK}$  voltage is less than 1V. The sensitivity in this operation is high.

If the MPX signal is noisy (low field strength) the  $V_{PEAK}$  voltage increases due to the higher noise, which is also rectified. With increasing of the  $V_{PEAK}$  voltage the trigger threshold increases, too. This particular gain is programmable in 4 steps (NBCT).

**Figure 5. Adaptive threshold control of noise blanker**

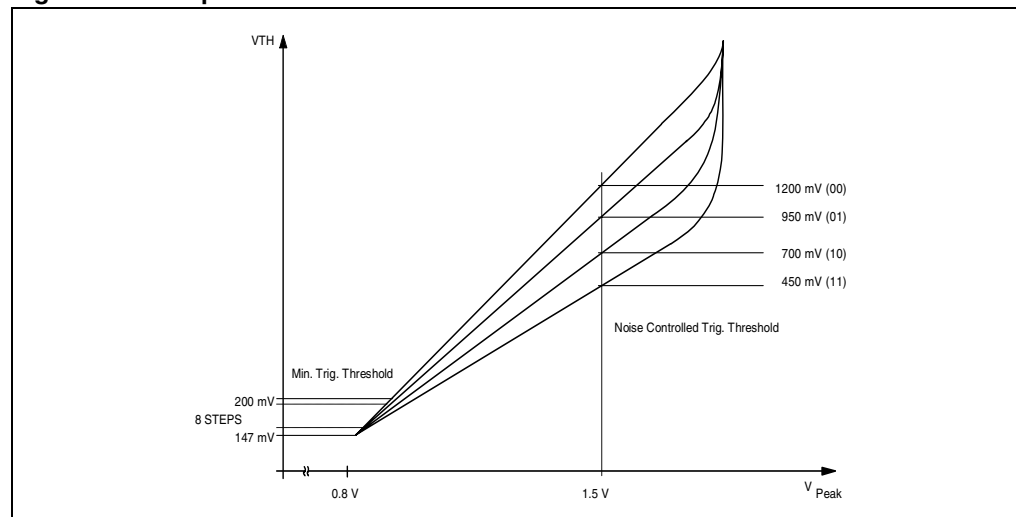

### Automatic stereo blend controlled threshold adjustment

Besides the noise controlled threshold adjustment there is an additional possibility for influencing the noise blanker trigger threshold using the bits NBFC. This influence depends on the stereo blend control. The point where the MPX signal starts to become noisy is fixed by the RF part. This point is also the starting point of the normal noise-controlled trigger adjustment. But in some cases the noise blanker can create a wrong triggering, which create distortion, already in the region of mono/stereo transition. Therefore an opportunity to control the  $V_{PEAK}$  voltage by the stereo blend function it is implemented.

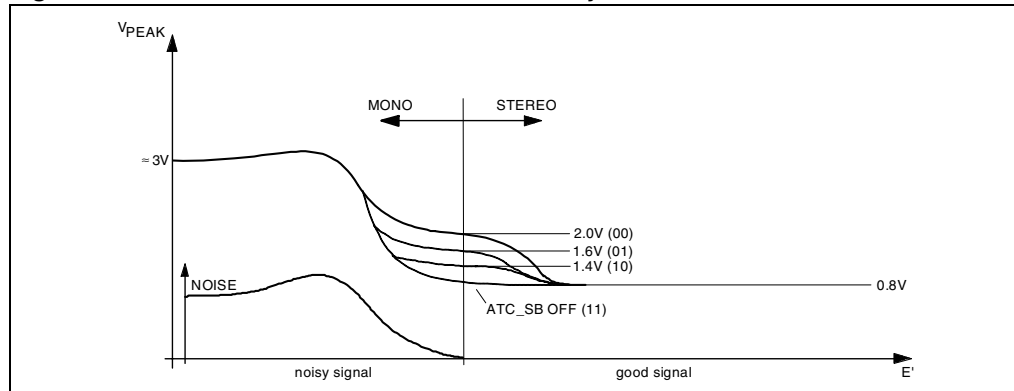
**Figure 6. Stereo blend controlled threshold adjust****Automatic deviation controlled threshold adjustment**

If the system is tuned to stations with a high deviation the noise blanker can trigger on the higher frequencies of the modulation. To avoid this wrong behavior, which causes noise in the output signal, the noise blanker offers a deviation-dependent threshold adjustment. By rectifying the MPX signal a further signal representing the actual deviation is obtained. It is used to increase the PEAK voltage. The gain of this circuit is programmable in 3 steps (NBDC) of the stereo decoder-byte (the first step turns off the detector).

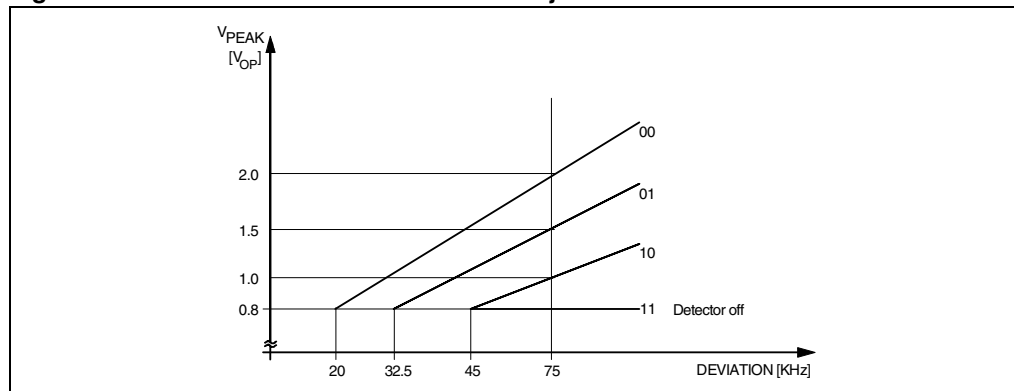
**Figure 7. Deviation controlled threshold adjust****Multipath influence on noise blanker**

To react on high repetitive spikes caused by a Multipath-situation, the discharge-time of the  $V_{PEAK}$  voltage can be decreased depending on the voltage-level at Pin MPTC. There are two ways to do this.

- Switch on the linear influence of the Multipath-Level on the PEAK-signal. In this case the discharge slew rate is 1 V/ms. The slew rate is measured with  $R_{Discharge} = \infty$  and  $V_{MPTC} = 2.5$  V
- Activate a function, which switches to the 18k discharge resistor if the Multipath-Level is below 2.5 V. If multipath influence on noise blanker is switched ON then MPF bit has to be set to 0.

### Noise blanker in AM mode

In AM mode the noise blanker is activated if a spike on the audio signal is bigger than a fixed threshold. In order to blank the whole spike in AM mode the hold time of the S&H circuit is much longer than in FM mode (64 0µs -1,2 ms). It is not recommended to use the AM noise blanker without to use the AMIF noise blanker inside the tuner.

### 4.3.3 Functional description of the multipath detector

Using the internal multi path detector the audible effects of a multi path condition can be minimized. A multi path condition is detected by rectifying the 19 kHz spectrum in the field strength signal. An external capacitor is used to define the attack- and decay-times. The MPTC pin is used as detector output connected to a capacitor. Using this configuration an external adaptation to the user's requirement is possible without affecting the "normal" field strength input (FSTC) for the stereo decoder.

To keep the old value of the multi path detector during an alternative frequency jump, the MPFAST bit can disconnect the external capacitor.

Selecting MPINT the channel separation is automatically reduced during a multipath condition according to the voltage appearing at the MPTC pin.

To obtain a good multipath performance an adaptation is necessary. Therefore the gain of the 19 kHz band pass is programmable in four steps (MPG) and the rectifier gain is programmable in four steps (MPRG). The attack- and decay-times can be set by the external capacitor value and the multipath detector charge current MPCC.

### 4.3.4 Quality detector

The TDA7541B offers a quality detector output, which gives a voltage representing the FM-reception conditions. To calculate this voltage the MPX-noise and the multipath-detector output are summed according to the following formula:

$$V_{Qual} = 0.8 \cdot b \cdot (V_{PEAK} - 0.8) + a \cdot (V_{REF1} - V_{MPTC})$$

The  $V_{PEAK}$  signal is described in noise blanker session. The factor 'a' can be programmed from 0.6 to 1.05 (QDC) and the factor b can be programmed from 6 dB to 15 dB (QNG). The quality output voltage can be read at the MUX pin. The MUX pin is a low impedance output and is able to drive external circuitry as well as simply fed to an AD-converter for RDS applications.

### 4.3.5 AFS control and stereo decoder mute

In case of AFS (alternative frequency search) jump it is recommended to set the stereo decoder in mute condition (SDM) and in addition to set the SEEK mode. Since these two bits are placed in the first written byte, this can be done in the same write cycle as the PLL jump. The stereo decoder mute is high impedance mute, which means the charge on the coupling capacitor will be kept. Simultaneously the pilot detector circuit of the stereo decoder is switched into hold mode. The SEEK mode is switching the multi path detector into fast mode. The external capacitor at MPTC is disconnected from multipath detector which keeps the stereo blend condition, but makes the quality information in fast mode available at the MUX pin.

## 4.4 PLL and IF counter section

### 4.4.1 PLL frequency synthesizer block

This part contains a frequency synthesizer and a loop filter for radio tuning system. Only one VCO is required to build a complete PLL system for FM world tuning and AM up conversion.

#### VCO and dividers

The varactor tuned LC oscillator together with the dividers provides the local oscillator signal for both AM and FM front-end mixers. The VCO has an operating frequency of approximately 160 MHz to 260 MHz. In FM mode the VCO frequency is divided (VCOD) by 1, 2 or 3. These dividers generate in-phase and quadrature-phase output signals using in FM mixer for image rejection.

In AM mode the divided VCO frequency is additional pre-divided (AMD) by 4, 6, 8 or 10 dependent on selected AM band.

#### PLL frequency generation for phase comparison

The VCO divided signals applies a two modulus counter (32/33), which is controlled by a 5-bit A-divider. The 5-bit register (PC0 to PC4) controls this divider. In parallel the output of the swallow counter is connected to an 11-bit B-divider. The 11-bit PC register (PC5 to PC15) controls this divider. Dividing range behind VCO divider:

$$f_{\text{VCOdiv}} = [32 \cdot B + A + 32] \cdot f_{\text{REF}}$$

---

**Warning:** For correct operation:  $A \leq 32$ ;  $B \geq A$

---

#### Crystal oscillator

The crystal oscillator provides 10.25 MHz signal for conversion from IF1 to IF2 as well as switching signals for ISS- and quality detection filter. Furthermore reference dividers generate from adjustable crystal frequency (XTAL) reference frequencies for the tuning PLL, IF counter and FM demodulator.

The various reference frequencies  $f_{\text{REF}}$  of PLL (RC) can be chosen by IIC-bus.

#### Three state phase comparator

The phase comparator generates a phase error signal according to phase difference between  $f_{\text{SYN}}$  and  $f_{\text{REF}}$ . This phase error signal drives the charge pump current generator.

#### Charge pump current generator

This system generator signed pulses of current. The phase error signal decides the duration and polarity of those pulses. The current absolute values are programmable by register ICP.

#### In lock detector

After reaching a phase difference about lower than 40 ns the inlock detector is automatically switching the charge-pump in low current mode (LDENA).

### Low noise CMOS op-amp

An internal voltage divider at pin 19 connects the positive input of the low noise op-amp. The charge pump output connects the negative input. This internal amplifier in cooperation with external components can provide an active filter. The negative input is switchable to two input pins, to increase the flexibility in application. While the high current mode is activated LPHC output is switched on.

### Antenna DAC

For tuning of FM antenna tank circuit two different modes are available (TVM). One is the auto-alignment measurement of VCO tuning voltage with offset of 8-bit DAC (TVO). The other one is an adjustment of 8-bit DAC independent on PLL tracking. For big differences between VCO tuning voltage and antenna tank control voltage an additional constant offset voltage can be switched to antenna circuit (TVO+).

## 4.4.2 IF counter block

The aim of IF counter is it to measure the intermediate frequency of the tuner. The input signals are the output level of 10.7 MHz IF-limiter in FM and output level of 450 kHz IF-limiter in AM.

The grade of integration is adjustable by different measuring cycle times (IFS). The tolerance of the accepted count value is adjustable too (EW), to reach an optimum compromise for search speed and precision of the evaluation.

### Sampling timer

A sampling timer generates the gate signal for the main counter. The basically sampling time are in FM 6.25 kHz ( $t_{TIM} = 160$  s) and in AM 1 kHz ( $t_{TIM} = 1$  ms). This is followed by an asynchronous divider to generate several sampling times.

### Intermediate frequency main counter

This counter is an 11 - 21-bit synchronous auto reload down counter. The counter length is automatic adjusted to the chosen sampling time and the counter mode (FM or AM).

At the start the counter will be loaded with a defined value which is an equivalent to the divider value ( $t_{Sample} \times f_{IF}$ ).

If a correct frequency is applied to the IF counter frequency input at the end of the sampling time the main counter is changing its state. This is detected by control logic and an external search stop output is changing from LOW to HIGH.

The IF counter is started only by the in lock information from the PLL part.

## 4.5 I<sup>2</sup>C bus interface

The TDA7541B supports the I<sup>2</sup>C bus protocol. This protocol defines any device that sends data onto the bus as a transmitter, and the receiving device as the receiver. The device that controls the transfer is a master and device being controlled is the slave. The master will always initiate data transfer and provide the clock to transmit or receive operations.

### Data transition

Data transition on the SDA line must only occur when the clock SCL is LOW. SDA transitions while SCL is HIGH will be interpreted as START or STOP condition.

### Start condition

A start condition is defined by a HIGH to LOW transition of the SDA line while SCL is at a stable HIGH level. This "START" condition must precede any command and initiate a data transfer onto the bus. The device continuously monitors the SDA and SCL lines for a valid START and will not response to any command if this condition has not been met.

### Stop condition

A STOP condition is defined by a LOW to HIGH transition of the SDA while the SCL line is at a stable HIGH level. This condition terminates the communication between the devices and forces the bus-interface of the device into the initial condition.

### Acknowledge

Indicates a successful data transfer. The transmitter will release the bus after sending 8 bits of data. During the 9<sup>th</sup> clock cycle the receiver will pull the SDA line to LOW level to indicate it receives the eight bits of data.

### Data transfer

During data transfer the device samples the SDA line on the leading edge of the SCL clock. Therefore, for proper device operation the SDA line must be stable during the SCL LOW to HIGH transition.

### Device addressing

To start the communication between two devices, the bus master must initiate a start instruction sequence, followed by an eight bit word corresponding to the address of the device it is addressing.

The most significant 6 bits of the slave address are the device type identifier.

The TDA7541B device type is fixed as "110001".

The next significant bit is used to address a particular device of the previous defined type connected to the bus.

The state of the hardwired PIN 57 defines the state of this address bit. Using this feature up to two devices could be connected on the same bus. When PIN 57 is connected to VCC via an external resistor of about 82 k $\Omega$  the address bit "1" is selected. Please note: in this case the AM part doesn't work. Otherwise the address bit "0" is selected (FM and AM is working). Therefore a double FM tuner concept is possible.

The last bit of the start instruction defines the type of operation to be performed:

- When set to "1", a read operation is selected
- When set to "0", a write operation is selected

The TDA7541B connected to the bus will compare their own hardwired address with the slave address being transmitted, after detecting a START condition. After this comparison, the TDA7541B will generate an "acknowledge" on the SDA line and will do either a read or a write operation according to the state of R/W bit.



### Write operation

Following a START condition the master sends a slave address word with the R/W bit set to "0". The device will generate an "acknowledge" after this first transmission and will wait for a second word (the word address field). This 8-bit address field provides an access to any of the 32 internal addresses. Upon receipt of the word address the TDA7541B slave device will respond with an "acknowledge". At this time, all the following words transmitted to the TDA7541B will be considered as Data. The internal address will be automatically incremented. After each word receipt the TDA7541B will answer with an "acknowledge".

### Read operation

If the master sends a slave address word with the R/W bit set to "1", the TDA7541B will transmit one 8-bit data word. This data word includes the following informations.

- bit0 (ISS filter, 1 = ON, 0 = OFF)
- bit1 (ISS filter bandwidth, 1 = 80 kHz, 0 = 120 kHz)
- bit2 (STEREO, 1 = STEREO, 0 = MONO)
- bit3 (1 = PLL is locked in, 0 = PLL is locked out).
- bit4 (fieldstrength indicator, 1 = lower as softmute threshold,  
0 = higher as softmute threshold)
- bit5 (adjacent channel indicator, 1 = adjacent channel present,  
0 = no adjacent channel)
- bit6 (deviation indicator, 1 = strong overdeviation present,  
0 = no strong overdeviation)
- bit7 (deviation indicator, 1 = overdeviation present,  
0 = no overdeviation)

## 5 Software specification

### 5.1 Chip address and overview

The interface protocol comprises:

- start condition (S)
- chip address byte
- sub address byte
- sequence of data (N bytes + Acknowledge)
- stop condition (P)

Receive mode																						
S	1	1	0	0	0	1	D	0	ACK	0	0	I	A4	A3	A2	A1	A0	ACK	DATA	BYTE	ACK	P
Transmission mode																						
S	1	1	0	0	0	1	D	1	ACK	R7	R6	R5	R4	R3	R2	R1	S0	ACK		P		

S = Start

P = Stop

ACK = Acknowledge

D = Device address

I = Auto increment mode

A = Sub address

R = Read bit

## 5.2 Address organization

Table 14. Address organization

Function	Addr	D7	D6	D5	D4	D3	D2	D1	D0
T PLL charge pump	0	SEEK	ASFC	LM	SDM	LDENA	ICP2	ICP1	ICP0
T PLL counter	1	PC7	PC6	PC5	PC4	PC3	PC2	PC1	PC0
T PLL counter	2	PC15	PC14	PC13	PC12	PC11	PC10	PC9	PC8
T TV	3	TVO7	TVO6	TVO5	TVO4	TVO3	TVO2	TVO1	TVO0
T TV/IF counter	4	FMON	EW6	EW5	IFS4	IFS3	ISSENA	TVM	TVO+
T PLL divider	5	AMD7	AMD6	RC5	RC4	RC3	VCOD2	VCOD1	VCOD0
T AGC	6	LNA7	LNA6	DAGC5	DAGC4	IFAGC3	IFAGC2	RFAGC1	RFAGC0
T Quality AC	7	TISS7	TISS6	TISS5	ACTH4	ACTH3	ACF	BWDEF	ISSBW
T Quality ACM/MP	8	MPTH7	MPTH6	MPAC	MPENA	ACMD	ACMTH2	ACMTH1	ACMTH0
T Quality DEV	9	ISSM	DTH6	DTH5	DWTH4	DWTH3	TDEV2	TDEV1	TDEV0
T Quality MUX/FSU	10	SSTH7	SSTH6	SSTH5	SSTH4	SACCT	SACCE	MUX1	MUX0
T Weak signal mute	11	WMD7	WMD6	WMD5	WMTH4	WMTH3	WMTH2	WBON	ISSON
T AM IF NB	12	IFAGCS	AIN7	AIN6	AIN5	AIN4	AIN3	AIN2	AIN1
T XTAL adjust	13	SL7	SL6	SL5	XTAL4	XTAL3	XTAL2	XTAL1	XTAL0
T IF adjust	14	IF1G7	IF1G6	IF2Q5	IF2Q4	IF2A3	IF2A2	IF2A1	IF2A0
T IQ adjust/Switch	15	DSB7	DSB6	SWM	SW	PH3	PH2	PH1	PH0
T FM keying AGC	16	FSWO7	FSWO6	RFK	KAGC4	KAGC3	KAGC2	ODCUR	ODENA
SD Roll off	17	LG7	LG6	LG5	LG4	ROC3	ROC2	ROC1	ROC0
SD Stereo blend	18	AMCF7	AMCF6	AMCF5	ASI	PTH	SBC2	SBC1	SBC0
SD High cut	19	DEEMP	HCLT6	HCLT5	HCHT4	HCHT3	HCMAX2	HCMAX1	HCENA
SD MP	20	MS	MPFAST	MPINT	MPCC	MPRG3	MPRG2	MPG1	MPG0
SD quality	21	NBFC7	NBFC6	NBDC5	NBDC4	QNG3	QNG2	QDC1	QDC0
SD Audio NB I	22	NBCT7	NBCT6	NBLT5	NBLT4	NBLT3	NBT2	NBT1	NBENA
SD Audio NB II	23	ADSEL	PCM	VCON	NBSMP	NBMP	NBRR2	NBRR1	NBPC
SD Testing	24	-	-	-	-	-	-	-	-
T PLL/IFC Testing	25	EWEXP	IFSEXP	1	1	1	1	1	1
T Testing	26	-	-	-	-	-	-	-	-
T Testing	27	-	-	-	-	-	-	-	-
T Testing	28	-	-	-	-	-	-	-	-
T Testing	29	-	-	-	-	-	-	-	-
Not used	30	-	-	-	-	-	-	-	-
Not used	31	-	-	-	-	-	-	-	-

T Tuner

SD Stereo decoder

Data bytes which are unused or dedicated for testing only don't need to be written, because they are set internally to FEH (power on reset condition). But if somebody is writing these bytes they must be written to FEH, otherwise some malfunction of the chip can happen.

### 5.3 Control register function

**Table 15. I<sup>2</sup>C control bit description**

Register Name	Function
ACF	Adjacent channel detector filter select
ACMD	Adjacent channel mute depth
ACMTH	Adjacent channel mute threshold
ACTH	Adjacent channel detector threshold
ADSEL	Additional selectivity
AINENA	AM IF noise blanker enable
AINT	AM IF noise blanking time
AINTH	AM IF noise blanker threshold
AMCF	Stereo decoder attenuation @ 3.5 kHz
AMD	AM VCO pre-divider
ASFC	Alternative station frequency check in FM (AGC and weak signal mute on hold)
ASI	Audio signal inversion
BWDEF	Enables bit ISSBW for ISS bandwidth control
DAGC	AM narrow band AGC threshold
DEEMP	Stereo decoder de-emphasis
DSB	FM demodulator spike blanker
DTH	Deviation detector threshold for ISS filter "OFF"
DWTH	Deviation detector threshold for ISS filter 120 kHz
EW	IF counter frequency error window
EWEXP	Expanded IF counter error window
FMON	Internal switch FM-AM mode
FSWO	Weighted fieldstrength with offset adjust
HCENA	High cut enable
HCHT	Start level high cut
HCLT	Stop level high cut
HCMAX	Maximum high cut depth
ICP	Charge pump current tuner PLL
IF1G	IF1 Amplifier Gain
IF2A	IF2 LC band pass fine adjust
IF2Q	IF2 LC band pass quality adjust
IFAGC	FM/AM IF AGC threshold
IFAGCS	AM IFAGC threshold shift

**Table 15. I<sup>2</sup>C control bit description (continued)**

Register Name	Function
IFS	IF counter sampling time
IFSEXP	Expanded IF counter sampling time
ISSBW	ISS filter band width select
ISSENA	ISS filter enable
ISSON	ISS filter control mode
ISSM	ISS filter application mode
KAGC	FM keying AGC
LDENA	Lock detector enable tuner PLL
LG	Stereo decoder level gain adjust
LM	FM local mode enable
LNA	AM LNA Pin/FET mode
MPAC	Influence tuner multi path detection on adjacent channel behavior
MPCC	Stereo decoder multi path detector charge current
MPENA	Tuner multi path detector influence on adjacent channel enable
MPFAST	Fast mode of multi path information at quality pin
MPG	Multi path detector gain
MPINT	Stereo decoder multi path internal influence enable
MPRG	Stereo decoder multi path detector rectifier gain
MPTH	Tuner multi path detector threshold
MS	Mono/Stereo switch fixed ("Forced Mono")
MUX	Output multiplexer for MUX pin
NBENA	Audio noise blanker enable
NBCT	Audio noise blanker noise controlled threshold
NBDC	Audio noise blanker deviation control
NBFC	Audio noise blanker field strength control
NBLT	Audio noise blanker low threshold
NBMP	Stereo decoder multi path influence on peak discharge current
NBPC	Audio noise blanker peak charge current
NBRR	Audio noise blanker rectifier discharge resistor
NBSMP	Strong multi path influence on audio noise blanker
NBT	Audio noise blanker time constant
ODCUR	Current for over deviation correction
ODENA	Over deviation correction enable
PC	Tuner PLL counter

**Table 15. I<sup>2</sup>C control bit description (continued)**

Register Name	Function
PCM	Pilot cancellation mode
PH	IQ mixer phase adjust
PTH	Pilot detector threshold
QDC	Stereo decoder quality detector coefficient
QNG	Stereo decoder quality noise gain
RC	Tuner PLL reference counter
RFAGC	FM/AM RF AGC threshold
RFK	FM RF keying AGC
ROC	Stereo decoder roll off compensation
SACCT	Strong adjacent channel correction threshold
SACCE	Strong adjacent channel correction enable
SBC	Stereo blend control
SDM	Stereo decoder mute enable
SEEK	FM: FMON = 1, ISS time constant change / AM: FMON = 0, AGC2 time constant change
SL	S meter slope
SSTH	Field strength threshold for seek stop
SW	Free programmable switch
SWM	Free programmable switch mode
TDEV	Time constant for deviation detector
TISS	Time constant for ISS filter "ON"/"OFF"
TVM	Tuning voltage offset mode
TVO	Tuning voltage offset
TVO+	Additional fixed tuning voltage offset
VCOD	Tuner VCO divider
VCON	STD VCO "ON/OFF"
WBON	Weather band mode (ISS filter band width 24 kHz)
WMD	Weak signal mute depth
WMTH	Weak signal mute start point threshold
XTAL	Xtal frequency fine adjust

## 5.4 Data byte specification

Table 16. Subaddress description

MSB							LSB	Function
-	-	I	A4	A3	A2	A1	A0	
-	-	-	0	0	0	0	0	Charge pump control
-	-	-	1	0	1	1	1	Audio noise blanker II
-	-	0 1	-	-	-	-	-	Page mode "OFF" Page mode enable

Table 17. Addr 0 TPLL charge pump control (0Bh)

MSB							LSB	Function
d7	d6	d5	d4	d3	d2	d1	d0	
-	-	-	-	-	0 0 0 0	0 0 1 1	0 1 0 1	<b>ICP&lt;2:0&gt;</b> Charge pump current = 50 $\mu$ A Charge pump current = 0.5 mA Charge pump current = 1 mA Charge pump current = 1.5 mA
-	-	-	-	0 1	-	1 1	0 1	<b>LDENA</b> Lock detector disable Lock detector enable
-	-	-	0 1	-	-	-	-	<b>SDM</b> Stereo decoder mute disable Stereo decoder mute enable
-	-	0 1	-	-	-	-	-	<b>LM</b> Local mode disable Local mode enable
-	0 1	-	-	-	-	-	-	<b>ASFC</b> Weak signal mute and AGC normal mode in FM Weak signal mute and AGC on hold in FM mode
0 1	-	-	-	-	-	-	-	<b>SEEK</b> ISS time constant at pin 30 available, AM SEEK "OFF" ISS time constant at pin 31 available, AM SEEK "ON"

Table 18. Addr 1 TPLL Counter 1 (LSB)

MSB							LSB	Function
d7	d6	d5	d4	d3	d2	d1	d0	
0	0	0	0	0	0	0	0	PC<7:0> LSB = 0
0	0	0	0	0	0	0	1	LSB = 1
0	0	0	0	0	0	1	0	LSB = 2
1	1	1	1	1	1	0	0	LSB = 252
1	1	1	1	1	1	0	1	LSB = 253
1	1	1	1	1	1	1	0	LSB = 254
1	1	1	1	1	1	1	1	LSB = 255

Table 19. Addr 2 TPLL Counter 2 (MSB)

MSB							LSB	Function
d7	d6	d5	d4	d3	d2	d1	d0	
0	0	0	0	0	0	0	0	PC<15:8> MSB = 0
0	0	0	0	0	0	0	1	MSB = 256
0	0	0	0	0	0	1	0	MSB = 512
1	1	1	1	1	1	0	0	MSB = 64768
1	1	1	1	1	1	0	1	MSB = 65024
1	1	1	1	1	1	1	0	MSB = 65280
1	1	1	1	1	1	1	1	MSB = 65536

Note: Swallow mode:  $fVCO/fSYN = LSB + MSB + 32$

Table 20. Addr 3 TV(00h)

MSB							LSB	Function
d7	d6	d5	d4	d3	d2	d1	d0	
	0	0	0	0	0	0	0	TVO<7:0> <u>Tuning Voltage Offset = 0mV</u>
	0	0	0	0	0	0	1	TVO = 25 mV
	0	0	0	0	0	1	0	TVO = 50 mV
	1	1	1	1	1	1	0	TVO = 3150 mV
	1	1	1	1	1	1	1	TVO = 3175 mV
0	-	-	-	-	-	-	-	-TVO
1	-	-	-	-	-	-	-	+TVO



Table 21. Addr 4 TV/IF Counter (FM ACh, AM 1Ch)

Addr25		MSB								LSB		Function
d7	d6	d7	d6	d5	d4	d3	d2	d1	d0			
-	-	-	-	-	-	-	-	-	-	0	<b>TVO+</b> Disable additional TV offset	
-	-	-	-	-	-	-	-	-	-	1	Enable additional TV offset + 3.175 V	
-	-	-	-	-	-	-	-	-	0	-	<b>TVM</b> TV is tracking with PLL	
-	-	-	-	-	-	-	-	-	1	-	TV is independing on PLL	
-	-	-	-	-	-	-	-	0	-	-	<b>ISSENA</b> ISS Filter switched off (bypass of filter, wide)	
-	-	-	-	-	-	-	-	1	-	-	ISS filter control enable	
-	1	-	-	-	0	0	-	-	-	-	<b>IFS&lt;4:3&gt;</b> $t_{\text{Sample}} = 20.48 \text{ ms (FM) } 128 \text{ ms (AM)}$	
-	1	-	-	-	0	1	-	-	-	-	<del><math>t_{\text{Sample}} = 10.24 \text{ ms (FM) } 64 \text{ ms (AM)}</math></del>	
-	1	-	-	-	1	0	-	-	-	-	$t_{\text{Sample}} = 5.12 \text{ ms (FM) } 32 \text{ ms (AM)}$	
-	1	-	-	-	1	1	-	-	-	-	<del><math>t_{\text{Sample}} = 2.56 \text{ ms (FM) } 16 \text{ ms (AM)}</math></del>	
-	0	-	-	-	0	0	-	-	-	-	$t_{\text{Sample}} = 1.28 \text{ ms (FM) } 8 \text{ ms (AM)}$	
-	0	-	-	-	0	1	-	-	-	-	$t_{\text{Sample}} = 0.64 \text{ ms (FM) } 4 \text{ ms (AM)}$	
-	0	-	-	-	1	0	-	-	-	-	$t_{\text{Sample}} = 0.32 \text{ ms (FM) } 2 \text{ ms (AM)}$	
-	0	-	-	-	1	1	-	-	-	-	$t_{\text{Sample}} = 0.16 \text{ ms (FM) } 1 \text{ ms (AM)}$	
1	-	-	0	0	-	-	-	-	-	-	<b>EW&lt;6:5&gt;</b> $\Delta f = 12.5 \text{ kHz (FM) } 2 \text{ kHz (AM)}$	
1	-	-	0	1	-	-	-	-	-	-	<del><math>\Delta f = 25 \text{ kHz (FM) } 4 \text{ kHz (AM)}</math></del>	
1	-	-	1	0	-	-	-	-	-	-	$\Delta f = 50 \text{ kHz (FM) } 8 \text{ kHz (AM)}$	
1	-	-	1	1	-	-	-	-	-	-	$\Delta f = 100\text{kHz (FM) } 16\text{kHz (AM)}$	
0	-	-	0	0	-	-	-	-	-	-	Not valid	
0	-	-	0	1	-	-	-	-	-	-	Not valid	
0	-	-	1	0	-	-	-	-	-	-	Not valid	
0	-	-	1	1	-	-	-	-	-	-	$\Delta f = 6.25 \text{ kHz (FM) } 1 \text{ kHz (AM)}$	
-	-	0	-	-	-	-	-	-	-	-	<b>FMON</b> Select AM mode	
-	-	1	-	-	-	-	-	-	-	-	Select FM mode	

Table 22. Addr 5 TPLL Divider (FM 3Dh, AM 2Dh)

MSB							LSB		Function
d7	d6	d5	d4	d3	d2	d1	d0		
-	-	-	-	-		0	0	<b>VCOD&lt;2:0&gt;</b> not valid (only for testing)	
						0	1	<u>VCO frequency divided by 2</u>	
						1	0	VCO frequency divided by 3	
						1	1	original VCO frequency	
					0			VCO "I" signal 0 degree	
					1			<u>VCO "I" signal 180 degree</u>	
-	-	0	1	1				<b>RC&lt;5:3&gt;</b> PLL reference frequency 2 kHz	
		1	0	0	-	-	-	PLL reference frequency 9 kHz	
		1	0	1				<u>PLL reference frequency 10 kHz (AM)</u>	
		1	1	0				PLL reference frequency 25 kHz	
		1	1	1				<u>PLL reference frequency 50 kHz (FM)</u>	
0	0							<b>AMD&lt;7:6&gt;</b> <u>AM VCO predivider ratio 10</u>	
0	1	-	-	-	-	-	-	AM VCO predivider ratio 8	
1	0							AM VCO predivider ratio 6	
1	1							AM VCO predivider ratio 4	

Table 23. Addr 6 AGC (FM 06h, AM 2Ah)

Addr12	MSB								LSB		Function
	d7	d7	d6	d5	d4	d3	d2	d1	d0		
											<b>RFAGC&lt;1:0&gt;</b>
-	-	-	-	-	-	-	-	0	0		RFAGC threshold FM $V_{8-10}= 80 \text{ dB}\mu\text{V}$ , AM $V_3= 92 \text{ dB}\mu\text{V}$
								0	1		RFAGC threshold FM $V_{8-10}= 84 \text{ dB}\mu\text{V}$ , AM $V_3= 99 \text{ dB}\mu\text{V}$
								1	0		<u>RFAGC threshold FM <math>V_{8-10}= 88 \text{ dB}\mu\text{V}</math>, AM <math>V_3= 102 \text{ dB}\mu\text{V}</math></u>
								1	1		RFAGC threshold FM $V_{8-10}= 92 \text{ dB}\mu\text{V}$ , AM $V_3= 104 \text{ dB}\mu\text{V}$
											<b>IFAGC&lt;3:2&gt;</b>
1						0	0				IFAGC threshold FM $V_{61}= 82 \text{ dB}\mu\text{V}$ , AM $V_{61}= 89 \text{ dB}\mu\text{V}$
1						0	1				<u>IFAGC threshold FM <math>V_{61}= 88 \text{ dB}\mu\text{V}</math>, AM <math>V_{61}= 95 \text{ dB}\mu\text{V}</math></u>
1						1	0				IFAGC threshold FM $V_{61}= 91 \text{ dB}\mu\text{V}$ , AM $V_{61}= 99 \text{ dB}\mu\text{V}$
1	-	-	-	-	1	1	-	-			IFAGC threshold FM $V_{61}= 94 \text{ dB}\mu\text{V}$ , AM $V_{61}= 102 \text{ dB}\mu\text{V}$
0						0	0				IFAGC threshold FM $V_{61}= 82 \text{ dB}\mu\text{V}$ , AM $V_{61}= 79 \text{ dB}\mu\text{V}$
0						0	1				IFAGC threshold FM $V_{61}= 88 \text{ dB}\mu\text{V}$ , AM $V_{61}= 85 \text{ dB}\mu\text{V}$
0						1	0				IFAGC threshold FM $V_{61}= 91 \text{ dB}\mu\text{V}$ , AM $V_{61}= 89 \text{ dB}\mu\text{V}$
0						1	1				IFAGC threshold FM $V_{61}= 94 \text{ dB}\mu\text{V}$ , AM $V_{61}= 92 \text{ dB}\mu\text{V}$
											<b>DAGC&lt;5:4&gt;</b>
-	-	-	0	0							DAGC $V_{56}= 86 \text{ dB}\mu$
			0	1	-	-	-	-			<u>DAGC <math>V_{56}= 91 \text{ dB}\mu</math></u>
			1	0							DAGC $V_{56}= 95 \text{ dB}\mu$
			1	1							DAGC $V_{56}= 98 \text{ dB}\mu$
											<b>LNA&lt;7:6&gt;</b>
-	0	0									$I_4 = 400 \mu\text{A}$ , $V_{54} = 4.5 \text{ V}$ , AM LNA Pin/FET mode "OFF"
	0	1	-	-	-	-	-	-			<u><math>I_4 = 400 \mu\text{A} + 50 \mu\text{A}</math>, <math>V_{54} = 3.5 \text{ V}</math></u>
	1	0									$I_4 = 400 \mu\text{A} + 100 \mu\text{A}$ , $V_{54} = 3.5 \text{ V}$
	1	1									$I_4 = 400 \mu\text{A} + 100 \mu\text{A}$ , $V_{54} = 3.5 \text{ V}$

Table 24. Addr 7 Quality AC (FM 50h)

MSB							LSB	Function
d7	d6	d5	d4	d3	d2	d1	d0	
-	-	-	-	-	-	-	0	<b>ISSBW</b> <u>ISS filter fixed band width 120 kHz</u>
							1	ISS filter fixed band width 80 kHz
-	-	-	-	-	-	0	-	<b>BWDEF</b> <u>Disable bit ISSBW for ISS filter band width control</u>
						1		Enable bit ISSBW for ISS filter band width control
-	-	-	-	-	0	-	-	<b>ACF</b> <u>AC highpass frequency 100 kHz</u>
					1			AC bandpass frequency 100 kHz
-	-	-	0	0				<b>ACTH&lt;4:3&gt;</b> AC detector threshold 0.35 V
			0	1	-	-	-	AC detector threshold 0.45 V
			1	0				<u>AC detector threshold 0.55 V</u>
			1	1				AC detector threshold 0.65 V
0	0	0						<b>TISS&lt;7:5&gt;</b> discharge current 1 $\mu$ A, charge current mid 74 $\mu$ A, narrow 124 $\mu$ A
0	0	1						discharge current 3 $\mu$ A, charge current mid 72 $\mu$ A, narrow 122 $\mu$ A
0	1	0	-	-	-	-	-	<u>discharge current 5 <math>\mu</math>A, charge current mid 70 <math>\mu</math>A, narrow 120 <math>\mu</math>A</u>
0	1	1						discharge current 7 $\mu$ A, charge current mid 68 $\mu$ A, narrow 118 $\mu$ A
1	1	1						discharge current 15 $\mu$ A, charge current mid 60 $\mu$ A, narrow 110 $\mu$ A

Table 25. Addr 8 Quality ACM/MP (FM 6Ah)

MSB				LSB				Function
d7	d6	d5	d4	d3	d2	d1	d0	
-	-	-	-	-	0	0	0	<b>ACMTH&lt;2:0&gt;</b> AC mute threshold 60 mV
					0	0	1	AC mute threshold 90 mV
					0	1	0	<u>AC mute threshold 150 mV</u>
					1	1	0	AC mute threshold 240 mV
					1	1	1	AC mute OFF
-	-	-	-	0	-	-	-	<b>ACMD</b> Adjacent channel mute depth -4 dB
				1	-	-	-	<u>Adjacent channel mute depth -6 dB</u>
-	-	-	0	-	-	-	-	<b>MPENA</b> <u>Multipath control "ON"</u>
			1	-	-	-	-	Multipath control "OFF"
-	-	0	-	-	-	-	-	<b>MPAC</b> Multipath eliminates ac (MPENA = 0)
		1	-	-	-	-	-	<u>Multipath eliminates ac and ac+</u> (MPENA = 0)
0	0							<b>MPTH&lt;7:6&gt;</b> MP threshold 0.50 V
0	1							<u>MP threshold 0.75 V</u>
1	0							MP threshold 1.00 V
1	1							MP threshold 1.25 V

Table 26. Addr 9 Quality Dev (FM 49h)

MSB							LSB	Function
d7	d6	d5	d4	d3	d2	d1	d0	
-	-	-	-	-	0	0	0	<b>TDEV&lt;2:0&gt;</b> charge current 39 $\mu$ A, discharge current 1 $\mu$ A
					0	0	1	<u>charge current 38 <math>\mu</math>A, discharge current 2 <math>\mu</math>A</u>
					0	1	0	charge current 37 $\mu$ A, discharge current 3 $\mu$ A
					0	1	1	charge current 36 $\mu$ A, discharge current 4 $\mu$ A
					1	1	0	charge current 33 $\mu$ A, discharge current 7 $\mu$ A
					1	1	1	charge current 32 $\mu$ A, discharge current 8 $\mu$ A
-	-	-	0	0				<b>DWTH&lt;4:3&gt;</b> DEV threshold for ISS narrow/wide 20 kHz
			0	1	-	-	-	<u>DEV threshold for ISS narrow/wide 30 kHz</u>
			1	0				DEV threshold for ISS narrow/wide 40 kHz
			1	1				DEV threshold for ISS narrow/wide 50 kHz
-	0	0						<b>DTH&lt;6:5&gt;</b> DEV threshold for ISS filter "OFF" ratio 1.5
	0	1	-	-	-	-	-	DEV threshold for ISS filter "OFF" ratio 1.4
	1	0						<u>DEV threshold for ISS filter "OFF" ratio 1.3</u>
	1	1						DEV threshold for ISS filter "OFF" ratio 1
0	-	-	-	-	-	-	-	<b>ISSM</b> <u>ISS filter application mode 1</u>
1								ISS filter application mode 2

Table 27. Addr 10 Quality MUX/FSU (FM 0Eh, AM 0Fh)

MSB							LSB		Function
d7	d6	d5	d4	d3	d2	d1	d0		
-	-	-	-	-	-	0	0	<b>MUX&lt;1:0&gt;</b> Detected multipath information at PIN 23	
-	-	-	-	-	-	0	1	Detected adjacent channel information at PIN 23	
-	-	-	-	-	-	1	0	<u>Quality information stereo decoder at PIN 23</u>	
-	-	-	-	-	-	1	1	FMON=1: Stereo indication at PIN 23 FMON=0: <u>AM IF2 signal at PIN 23</u>	
-	-	-	-	-	0	-	-	<b>SACCE</b> Strong adjacent channel correction disable <u>Strong adjacent channel correction enable</u>	
-	-	-	-	0	-	-	-	<b>SACCT</b> Strong adjacent channel correction threshold = 2.9 V <u>Strong adjacent channel correction threshold = 3.0V</u>	
0	0	0	0	-	-	-	-	<b>SSTH&lt;7:4&gt;</b> <u>SSTOP = IFC (IF counter status)</u> SSTOP = H if IFC = H & FS > (FM: 0.6 V / AM: 1.2 V)	
0	0	0	1	-	-	-	-	SSTOP = H if IFC = H & FS >	
0	0	1	0	-	-	-	-	SSTOP = H if IFC = H & FS >	
0	0	1	1	-	-	-	-	SSTOP = H if IFC = H & FS >	
0	1	0	0	-	-	-	-	SSTOP = H if IFC = H & FS >	
1	1	1	1	-	-	-	-	SSTOP = H if IFC = H & FS > (FM: 4.1 V / AM: 4.8 V)	

Table 28. Addr 11 Weak Signal Mute (FM A8h)

MSB							LSB		Function
d7	d6	d5	d4	d3	d2	d1	d0		
-	-	-	-	-	-	-	0	<b>ISSON</b> <u>ISS filter internal control</u>	
-	-	-	-	-	-	-	1	ISS filter forced "ON"	
-	-	-	-	-	-	0	-	<b>WBON</b> <u>Weather band disable</u> Weather band enable	
-	-	-	0	0	0	-	-	<b>WMTH&lt;4:2&gt;</b> Startpoint mute 0	
-	-	-	0	0	1	-	-	Startpoint mute 1	
-	-	-	0	1	0	-	-	<u>Startpoint mute 2</u>	
-	-	-	1	1	0	-	-	Startpoint mute 6	
-	-	-	1	1	1	-	-	Startpoint mute 7	
0	0	0	-	-	-	-	-	<b>WMD&lt;7:5&gt;</b> Mute depth 0	
0	0	1	-	-	-	-	-	Mute depth 1	
1	0	1	-	-	-	-	-	<u>Mute depth 5</u>	
1	1	1	-	-	-	-	-	Mute depth 7	

Table 29. Addr 12 AM IF NB (AM B1h)

MSB							LSB	Function
d7	d6	d5	d4	d3	d2	d1	d0	
-	-	-	-	-	-	-	0	<b>AINENA</b> AM IF noise blanker disable
							1	<u>AM IF noise blanker enable</u>
			0	0	0	0		<b>AINTH&lt;4:1&gt;</b> not recommended
			-	-	-	-		-
			0	0	1	0		not recommended
			0	1	0	0		AM IF NB Threshold 50 mV
-	-	-	0	1	0	1	-	AM IF NB Threshold 62.5 mV
			-	-	-	-		-
			1	0	0	0		<u>AM IF NB Threshold 100 mV</u>
			-	-	-	-		-
			1	1	1	1		AM IF NB Threshold 187.5 mV
	0	0						<b>AINT&lt;6:5&gt;</b> AM IF NB Time 8 $\mu$ s
-	0	1	-	-	-	-	-	<u>AM IF NB Time 11 <math>\mu</math>s</u>
	1	0						AM IF NB Time 14 $\mu$ s
	1	1						AM IF NB Time 17 $\mu$ s
0	-	-	-	-	-	-	-	<b>IFAGCS</b> Enable AM IFAGC threshold shift down (check address6)
1								<u>Disable AM IFAGC threshold shift down</u>

Table 30. Addr 13 XTAL adjust(80h)

MSB							LSB	Function
d7	d6	d5	d4	d3	d2	d1	d0	
			0	0	0	0	0	<b>XTAL&lt;4:0&gt;</b> <u>C<sub>Load</sub> 0pF</u>
			0	0	0	0	1	C <sub>Load</sub> 0.75 pF
-	-	-	0	0	0	1	0	C <sub>Load</sub> 1.5 pF
			0	0	0	1	1	C <sub>Load</sub> 2.25 pF
			0	0	1	0	0	C <sub>Load</sub> 3 pF
			1	1	1	1	0	C <sub>Load</sub> 22.5 pF
			1	1	1	1	1	C <sub>Load</sub> 23.25 pF
0	0	0						<b>SL&lt;7:5&gt;</b> S meter slope FM = 0.75 V/20 dB, AM = 1.61 V/20 dB
0	0	1						S meter slope FM = 0.80 V/20 dB, AM = 1.75 V/20 dB
0	1	0						S meter slope FM = 0.85 V/20 dB, AM = 1.89 V/20 dB
0	1	1	-	-	-	-	-	S meter slope FM = 0.90 V/20 dB, AM = 1.98 V/20 dB
1	0	0						<u>S meter slope FM = 0.95 V/20 dB, AM = 2.04 V/20 dB</u>
1	0	1						S meter slope FM = 1.0 V/20 dB, AM = 2.1 V/20 dB
1	1	0						S meter slope FM = 1.05 V/20 dB, AM = 2.15 V/20 dB
1	1	1						S meter slope FM = 1.1 V/20 dB, AM = 2.20 V/20 dB



Table 31. Addr 14 IF2 adjust (FM E8h, AM 08h)

MSB				LSB				Function
d7	d6	d5	d4	d3	d2	d1	d0	
				0	0	0	0	<b>IF2A&lt;3:0&gt;</b> C <sub>adj</sub> 0 pF
				0	0	0	1	C <sub>adj</sub> 2,2 pF
-	-	-	-	0	0	1	0	C <sub>adj</sub> 4,4 pF
				0	0	1	1	C <sub>adj</sub> 6,6 pF
				0	1	0	0	C <sub>adj</sub> 8,8 pF
				1	0	0	0	C <sub>adj</sub> 17.6 pF
				1	1	1	1	C <sub>adj</sub> 33 pF
		0	0					<b>IF2Q&lt;5:4&gt;</b> no R <sub>int</sub> , AM Q=28/gain=26 dB, FM Q=28/gain=16 dB
-	-	0	1	-	-	-	-	R <sub>int</sub> =5 kOhm, FM Q=3/gain=14 dB, BW=150 kHz
		1	0					R <sub>int</sub> =4,1 kOhm, FM Q=2,5/gain=14 dB, BW=180 kHz
		1	1					R <sub>int</sub> =3,3 kOhm, FM Q=2,05/gain=14 dB, BW=220 kHz
0	0							<b>IF1G&lt;7:6&gt;</b> IF1 gain 9 dB (AM)
0	1	-	-	-	-	-	-	IF1 gain 12 dB
1	0							IF1 gain 17 dB
1	1							IF1 gain 21 dB (FM)

Table 32. Addr 15 IQ adjust / Switch (FM E7h)

MSB				LSB				Function
d7	d6	d5	d4	d3	d2	d1	d0	
				0	0	0	0	<b>PH&lt;3:0&gt;</b> -7 degree
				0	0	0	1	-6 degree
				0	0	1	0	-5 degree
-	-	-	-	0	1	1	1	<u>0 degree</u>
				1	0	0	0	1 degree
				1	0	0	1	2 degree
				1	1	1	0	7 degree
				1	1	1	1	8 degree
-	-	-	0	-	-	-	-	<b>SW</b> <u>S1 LOW output voltage</u> S1 HIGH output voltage
-	-	0	-	-	-	-	-	<b>SWM</b> S1 emitter output available <u>S1 open collector output available</u>
0	0							<b>DSB&lt;7:6&gt;</b> FM demodulator spike cancellation "OFF"
0	1	-	-	-	-	-	-	Threshold for FM demodulator spike cancellation 630 mV
1	0							Threshold for FM demodulator spike cancellation 400 mV
1	1							<u>Threshold for FM demodulator spike cancellation 520 mV</u>

Table 33. Addr 16 FM keying AGC (FM 1Dh)

MSB							LSB	Function
d7	d6	d5	d4	d3	d2	d1	d0	
-	-	-	-	-	-	-	0	<b>ODENA</b> Over deviation correction disable
							1	<u>Over deviation correction enable</u>
-	-	-	-	-	-	0	-	<b>ODCUR</b> <u>over deviation correction current max=45 µA</u>
						1		over deviation correction current max=90 µA
			0	0	0			<b>KAGC&lt;4:2&gt;</b> KAGC threshold $3,60 * V_{48} / 5$
			0	0	1			KAGC threshold $3,65 * V_{48} / 5$
			0	1	0			KAGC threshold $3,70 * V_{48} / 5$
-	-	-	0	1	1	-	-	KAGC threshold $3,75 * V_{48} / 5$
			1	0	0			KAGC threshold $3,80 * V_{48} / 5$
			1	0	1			KAGC threshold $3,85 * V_{48} / 5$
			1	1	0			KAGC threshold $3,90 * V_{48} / 5$
			1	1	1			<u>Keying AGC "OFF"</u>
-	-	0	-	-	-	-	-	<b>RFK</b> <u>RF keying AGC OFF</u>
		1						RF keying AGC ON
0	0							<b>FSWO&lt;7:6&gt;</b> <u>FSW offset OFF</u>
0	1	-	-	-	-	-	-	FSW offset = -75 mV
1	0							FSW offset = -150 mV
1	1							FSW offset = -192 mV

Table 34. Addr 17 Roll off / Level gain (77h)

MSB				LSB				Function
d7	d6	d5	d4	d3	d2	d1	d0	
				0	0	0	0	<b>ROC&lt;3:0&gt;</b> Roll-Off compensation 25.8 %
				0	0	0	1	Roll-Off compensation 24.0 %
				0	0	1	0	Roll-Off compensation 22.2 %
				0	0	1	1	Roll-Off compensation 20.5 %
				0	1	0	0	Roll-Off compensation 18.8 %
				0	1	0	1	Roll-Off compensation 17.1 %
				0	1	1	0	Roll-Off compensation 15.4 %
-	-	-	-	0	1	1	1	Roll-Off compensation 13.8 %
				1	0	0	0	Roll-Off compensation 12.2 %
				1	0	0	1	Roll-Off compensation 10.6 %
				1	0	1	0	Roll-Off compensation 9.0 %
				1	0	1	1	Roll-Off compensation 7.5 %
				1	1	0	0	<u>Roll-Off compensation 6.0 %</u>
				1	1	0	1	Roll-Off compensation 4.5 %
				1	1	1	0	Roll-Off compensation 3,0 %
				1	1	1	1	Roll-Off compensation 1.6 %
								<b>LG&lt;7:4&gt;</b>
0	0	0	0					Level gain 0 dB
0	0	0	1					Level gain 0.55 dB
0	0	1	0	-	-	-	-	Level gain 1.10 dB
0	1	1	1					<u>Level gain 3.85 dB</u>
1	1	1	1					Level gain 8.25 dB

Table 35. Addr 18 SD Stereoblend / AM corner frequency (0Dh)

MSB							LSB	Function
d7	d6	d5	d4	d3	d2	d1	d0	
					0	0	0	<b>SBC&lt;2:0&gt;</b> Stereoblend control at 29 % REF5V
					0	0	1	Stereoblend control at 33 % REF5V
					0	1	0	Stereoblend control at 38 % REF5V
-	-	-	-	-	0	1	1	Stereoblend control at 42 % REF5V
					1	0	0	Stereoblend control at 46 % REF5V
					1	0	1	<u>Stereoblend control at 50 % REF5V</u>
					1	1	0	Stereoblend control at 54 % REF5V
					1	1	1	Stereoblend control at 58 % REF5V
-	-	-	-	0	-	-	-	<b>PTH</b> Pilot threshold high
				1				<u>Pilot threshold low</u>
-	-	-	0	-	-	-	-	<b>ASI</b> <u>Audio inverter "OFF"</u>
			1					Audio inverter "ON"
0	0	0						<b>AMCF&lt;7:5&gt;</b> <u>AM attenuation @ 3.5 kHz = 8.4 dB</u>
0	0	1						AM attenuation @ 3.5 kHz = 8.0 dB
0	1	0	-	-	-	-	-	AM attenuation @ 3.5 kHz = 7.3 dB
1	1	0						AM attenuation @ 3.5 kHz = 4.4 dB
1	1	1						AM attenuation @ 3.5 kHz = 3.6 dB

Table 36. Addr 19 SD High cut (2Fh)

MSB							LSB	Function
d7	d6	d5	d4	d3	d2	d1	d0	
-	-	-	-	-	-	-	0	<b>HCENA</b> High cut "OFF"
							1	High cut "ON"
-	-	-	-	-	0	0	-	<b>HCMAX&lt;2:1&gt;</b> Maximum high cut 10 dB
					0	1	-	Maximum high cut 5.5 dB
					1	0	-	Maximum high cut 7.5 dB
					1	1	-	Maximum high cut 8.5 dB
-	-	-	0	0	-	-	-	<b>HCHT&lt;4:3&gt;</b> Start level high cut @ 42 % REF5V
			0	1	-	-	-	Start level high cut @ 50 % REF5V
			1	0	-	-	-	Start level high cut @ 58 % REF5V
			1	1	-	-	-	Start level high cut @ 66 % REF5V
-	0	0	-	-	-	-	-	<b>HCLT&lt;6:5&gt;</b> Stop level high cut @ 11 % $V_{HCHT}$
	0	1	-	-	-	-	-	Stop level high cut @ 18.3 % $V_{HCHT}$
	1	0	-	-	-	-	-	Stop level high cut @ 25.7 % $V_{HCHT}$
	1	1	-	-	-	-	-	Stop level high cut @ 33 % $V_{HCHT}$
0	-	-	-	-	-	-	-	<b>DEEMP</b> De-emphasis 50 $\mu$ s
1	-	-	-	-	-	-	-	De-emphasis 75 $\mu$ s

Table 37. Addr 20 SD MP (FM 97h, AM 3Fh)

MSB							LSB		Function
d7	d6	d5	d4	d3	d2	d1	d0		
-	-	-	-	-	-	0	0	<b>MPG&lt;1:0&gt;</b> Multipath detector gain =6 dB	
-	-	-	-	-	-	0	1	Multipath detector gain =12 dB	
-	-	-	-	-	-	1	0	Multipath detector gain =9 dB	
-	-	-	-	-	-	1	1	<u>Multipath detector gain =10.5 dB</u>	
-	-	-	-	0	0	-	-	<b>MPRG&lt;3:2&gt;</b> Multipath detector rectifier gain =7,6 dB	
-	-	-	-	0	1	-	-	<u>Multipath detector rectifier gain =4.6 dB</u>	
-	-	-	-	1	0	-	-	Multipath detector rectifier gain =0d B	
-	-	-	-	1	1	-	-	Multipath detector rectifier gain disabled	
-	-	-	0	-	-	-	-	<b>MPCC</b> Multipath detector charge current =0,8 $\mu$ A	
-	-	-	1	-	-	-	-	<u>Multipath detector charge current =0.4 <math>\mu</math>A</u>	
-	-	0	-	-	-	-	-	<b>MPINT</b> <u>Multipath detector internal influence "ON"</u>	
-	-	1	-	-	-	-	-	Multipath detector internal influence "OFF"	
-	0	-	-	-	-	-	-	<b>MPFAST</b> <u>External time constant (MPTC) enable</u>	
-	1	-	-	-	-	-	-	External time constant (MPTC) disable	
0	-	-	-	-	-	-	-	<b>MS</b> Forced MONO	
1	-	-	-	-	-	-	-	<u>MONO/STEREO switch automatically</u>	

Table 38. Addr 21 SD Quality (FFM 7Ah, AM FAh)

MSB				LSB				Function
d7	d6	d5	d4	d3	d2	d1	d0	
-	-	-	-	-	-	0	0	<b>QDC&lt;1:0&gt;</b> Quality detector coefficient a=0,6
						0	1	Quality detector coefficient a=0,75
						1	0	<u>Quality detector coefficient a=0,9</u>
						1	1	Quality detector coefficient a=1,05
-	-	-	-	0	0	-	-	<b>QNG&lt;3:2&gt;</b> Quality noise gain =6 dB
				0	1			Quality noise gain =9 dB
				1	0			<u>Quality noise gain =12 dB</u>
				1	1			Quality noise gain =15 dB
-	-	0	0	-	-	-	-	<b>NBDC&lt;5:4&gt;</b> Noise blanker deviation adjust 2.0 V
		0	1					Noise blanker deviation adjust 1.5 V
		1	0					Noise blanker deviation adjust 1.0 V
		1	1					<u>Noise blanker deviation adjust "OFF"</u>
0	0	-	-	-	-	-	-	<b>NBFC&lt;7:6&gt;</b> Noise blanker field strength adjust 2.0 V
0	1							<u>Noise blanker field strength adjust 1.6 V</u>
1	0							Noise blanker field strength adjust 1.4 V
1	1							Noise blanker field strength adjust "OFF"



Table 39. Addr 22 SD NB I (FM 05h, AM 04h)

MSB							LSB	Function
d7	d6	d5	d4	d3	d2	d1	d0	
-	-	-	-	-	-	-	0	<b>NBENA</b> Audio noise blanker "OFF"
							1	Audio noise blanker "ON"
-	-	-	-	-	0	0	-	<b>NBT&lt;2:1&gt;</b> Audio noise blanking time 38 $\mu$ s
					0	1	-	Audio noise blanking time 25,5 $\mu$ s
					1	0	-	Audio noise blanking time 32 $\mu$ s
					1	1	-	Audio noise blanking time 22 $\mu$ s
-	-	0	0	0	-	-	-	<b>NBLT&lt;5:3&gt;</b> <u>Noise blanker low threshold 280 mV</u>
		0	0	1				Noise blanker low threshold 261 mV
		0	1	0				Noise blanker low threshold 242 mV
		0	1	1	-	-	-	Noise blanker low threshold 223 mV
		1	0	0				Noise blanker low threshold 204 mV
		1	0	1				Noise blanker low threshold 185 mV
		1	1	0				Noise blanker low threshold 166 mV
		1	1	1				Noise blanker low threshold 147 mV
0	0						-	<b>NBCT&lt;7:6&gt;</b> <u>Noise blanker noise controlled threshold 1200 mV</u>
0	1	-	-	-	-	-	-	Noise blanker noise controlled threshold 950 mV
1	0						-	Noise blanker noise controlled threshold 700 mV
1	1						-	Noise blanker noise controlled threshold 450 mV

Table 40. Addr 23 SD NB II (FM E2h, AM C2h)

MSB							LSB	Function
d7	d6	d5	d4	d3	d2	d1	d0	
-	-	-	-	-	-	-	0	<b>NBPC</b> <u>Noise blanker peak charge current low</u>
							1	Noise blanker peak charge current high
-	-	-	-	-	0	0	-	<b>NBRR&lt;2:1&gt;</b> Noise rectifier discharge resistor = infinite
					0	1	-	<u>Noise rectifier discharge resistor =56 k</u>
					1	0	-	Noise rectifier discharge resistor =33 k
					1	1	-	Noise rectifier discharge resistor =18k
-	-	-	-	0	-	-	-	<b>NBMP</b> <u>Multipath influence on peak discharge "OFF"</u>
				1				Multipath influence on peak discharge "ON" (-3 V/ms)
-	-	-	0	-	-	-	-	<b>NBSMP</b> <u>Strong multipath influence on peak discharge "OFF"</u>
			1					Strong multipath influence on peak discharge "ON"
-	-	0	-	-	-	-	-	<b>VCON</b> Stereo decoder VCO "OFF"
		1						<u>Stereo decoder VCO "ON"</u>
-	0	-	-	-	-	-	-	<b>PCM</b> Pilot cancellation mode: always
	1							<u>Pilot cancellation mode: if pilot &gt; pilot threshold</u>
0	-	-	-	-	-	-	-	<b>ADSEL</b> Additional selectivity OFF
1								<u>Additional selectivity ON</u>

Table 41. Addr 24, 26, 27, 28, 29 testing (FEh)

MSB							LSB	Function
d7	d6	d5	d4	d3	d2	d1	d0	
1	1	1	1	1	1	1	0	Only for testing

Table 42. Addr 25 Testing (FEh)

MSB							LSB	Function
d7	d6	d5	d4	d3	d2	d1	d0	
-	-	1	1	1	1	1	0	Only for testing
-	0 1	-	-	-	-	-	-	<b>IFSEXP</b> Enable expand mode of IF sampling time (see addr 4) Disable expand mode of IF sampling time
0 1	-	-	-	-	-	-	-	<b>EWEXP</b> Enable expand mode of error window (see addr 4) Disable expand mode of error window

# 6 Appendix

Figure 8. Block diagram FM part

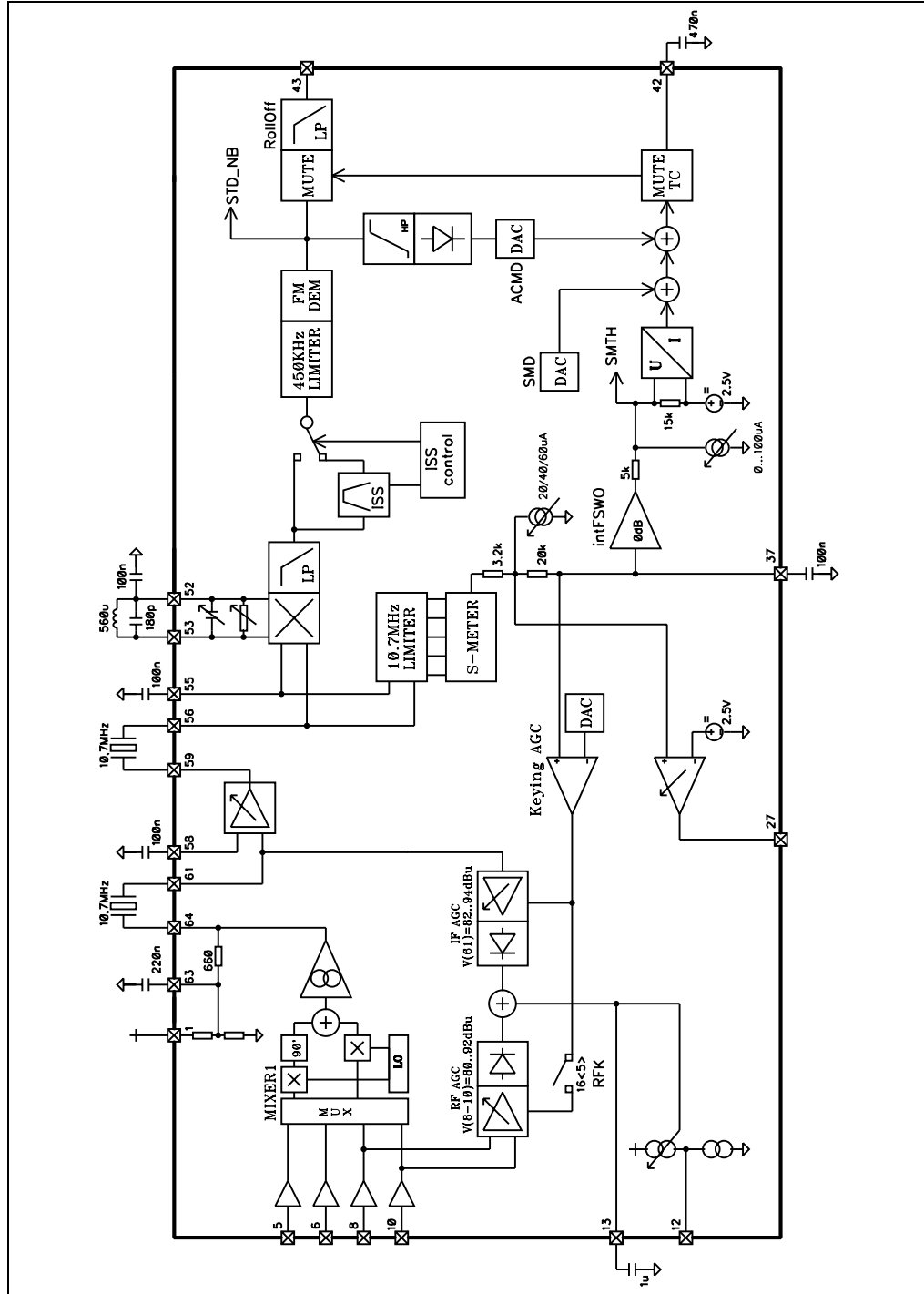

Figure 9. Block diagram VCO

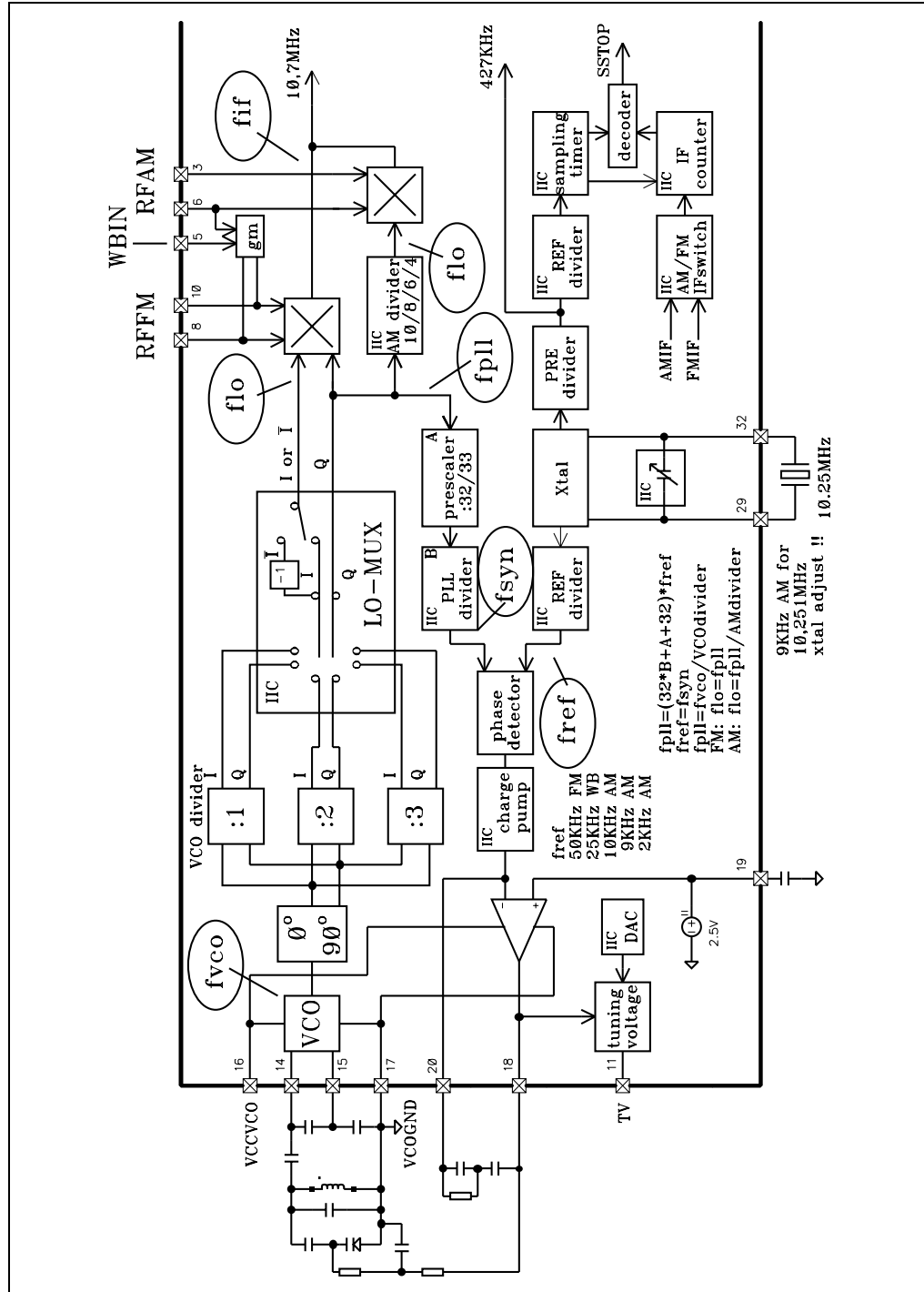

Figure 10. Block diagram ISS function

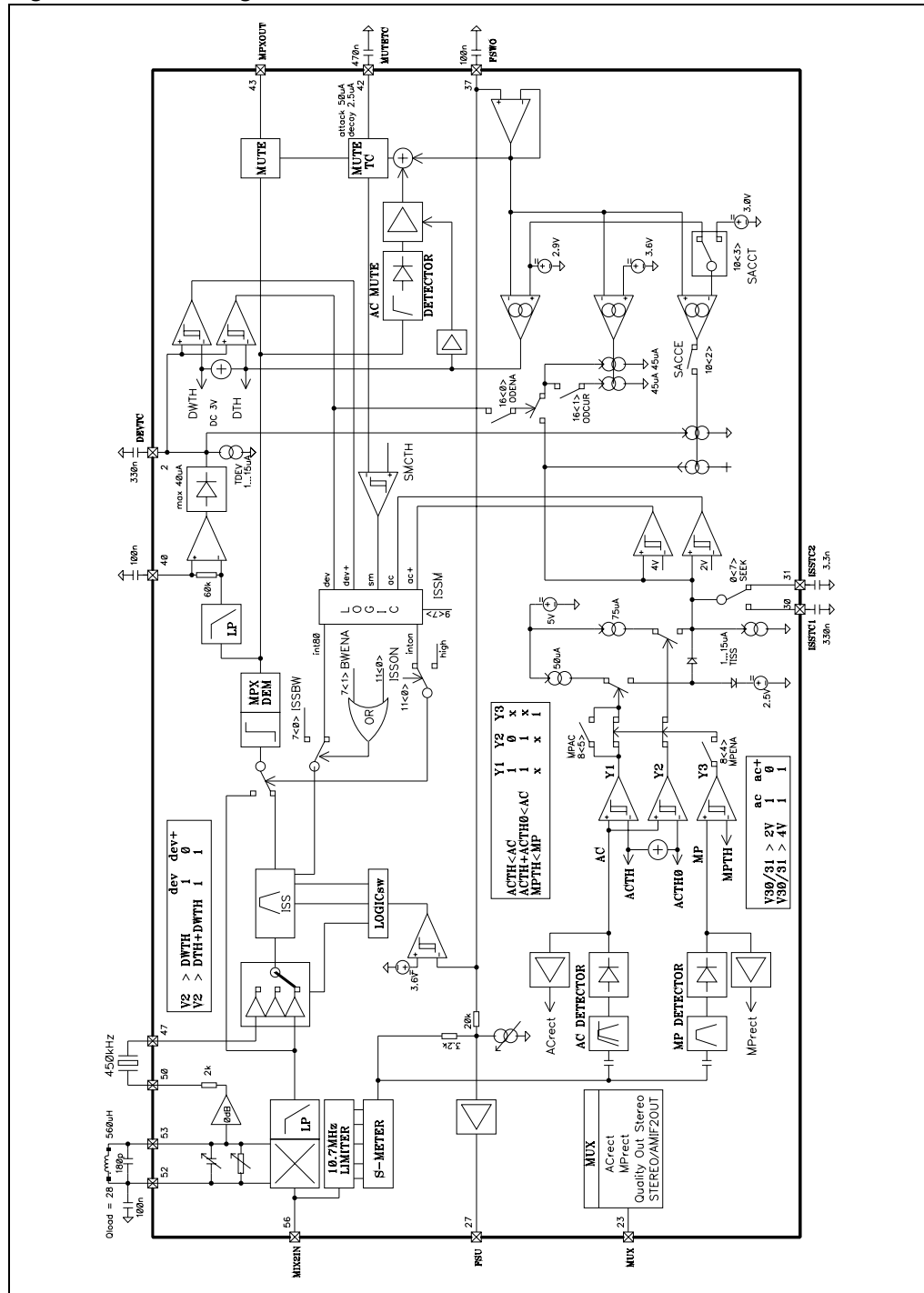

Figure 11. Block diagram AM path

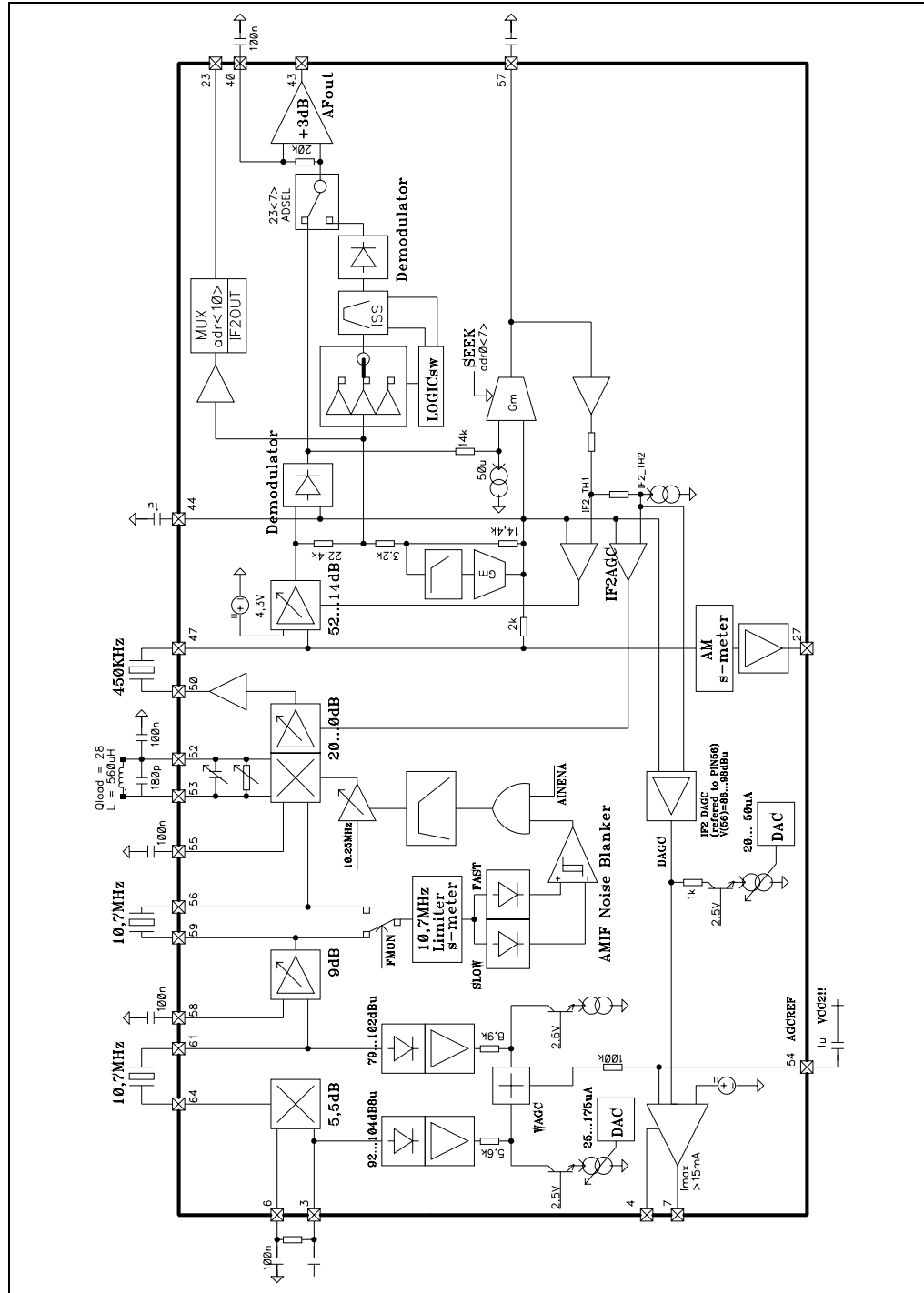

Figure 12. Block diagram stereo decoder

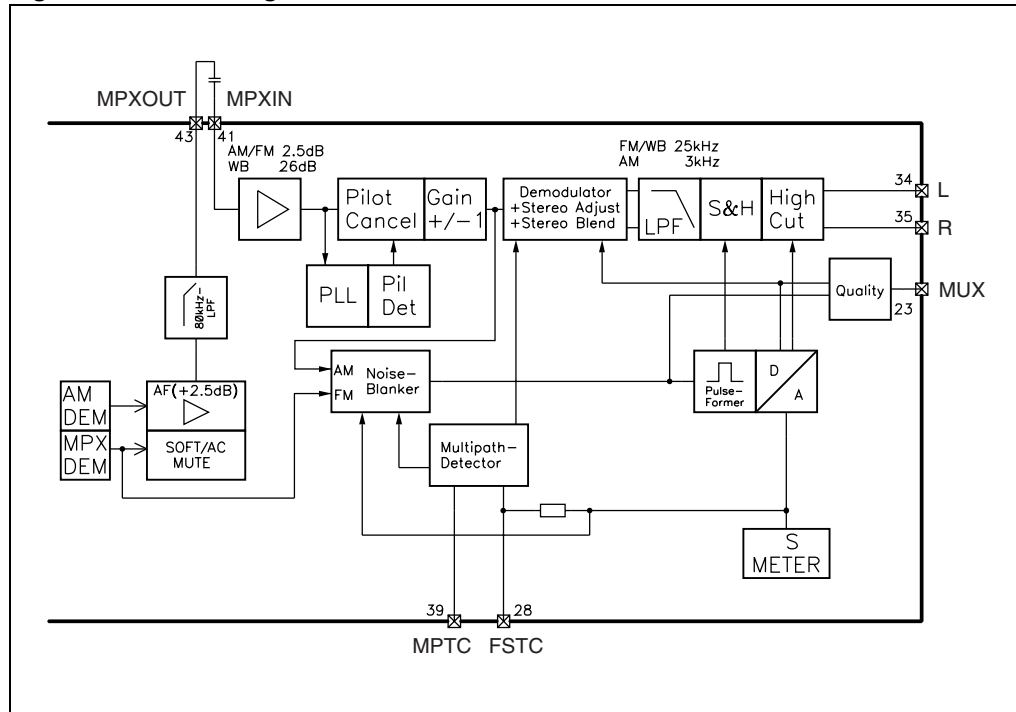

Figure 13. Block diagram audio noise blanker

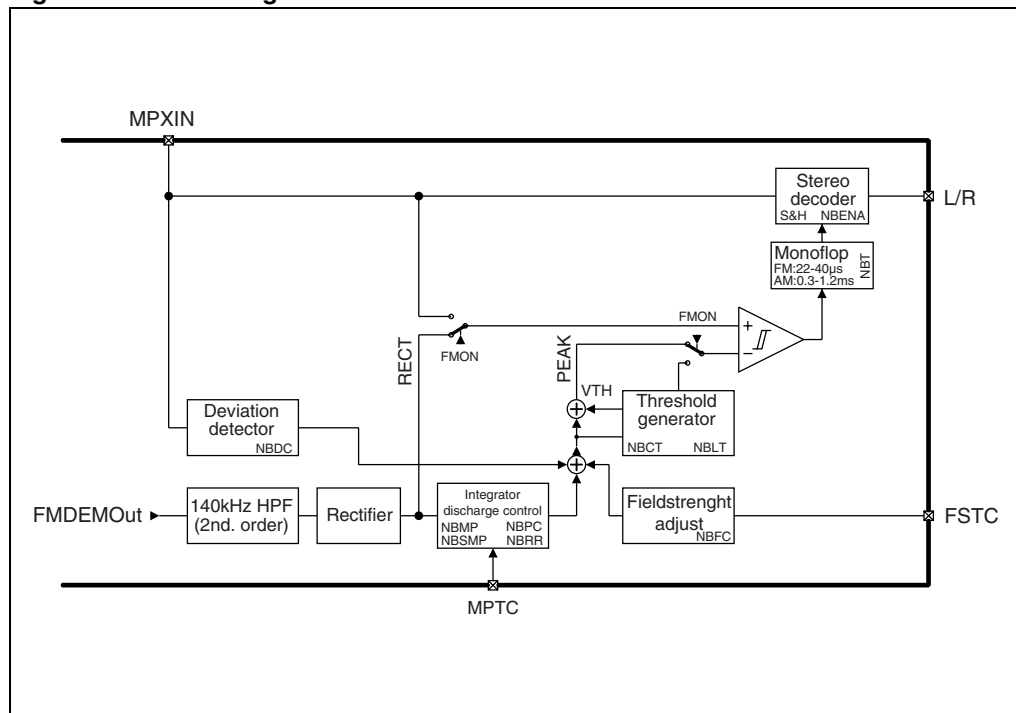
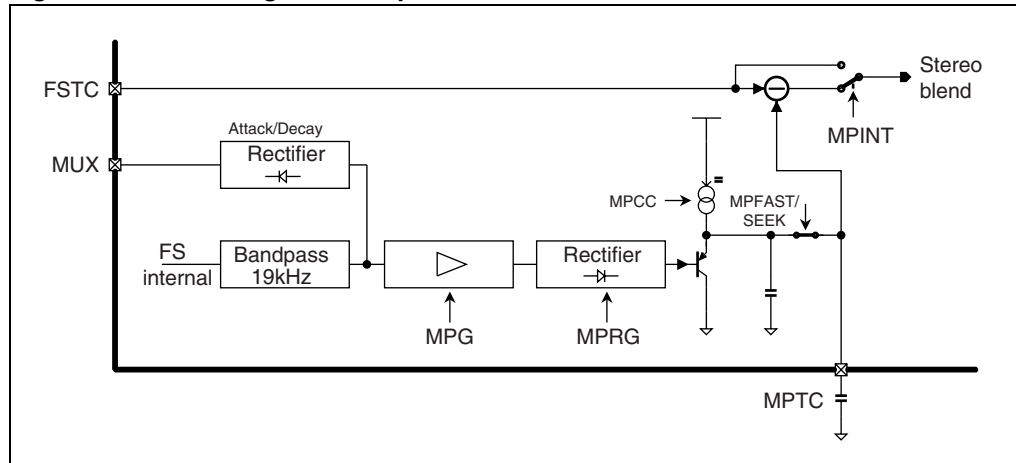

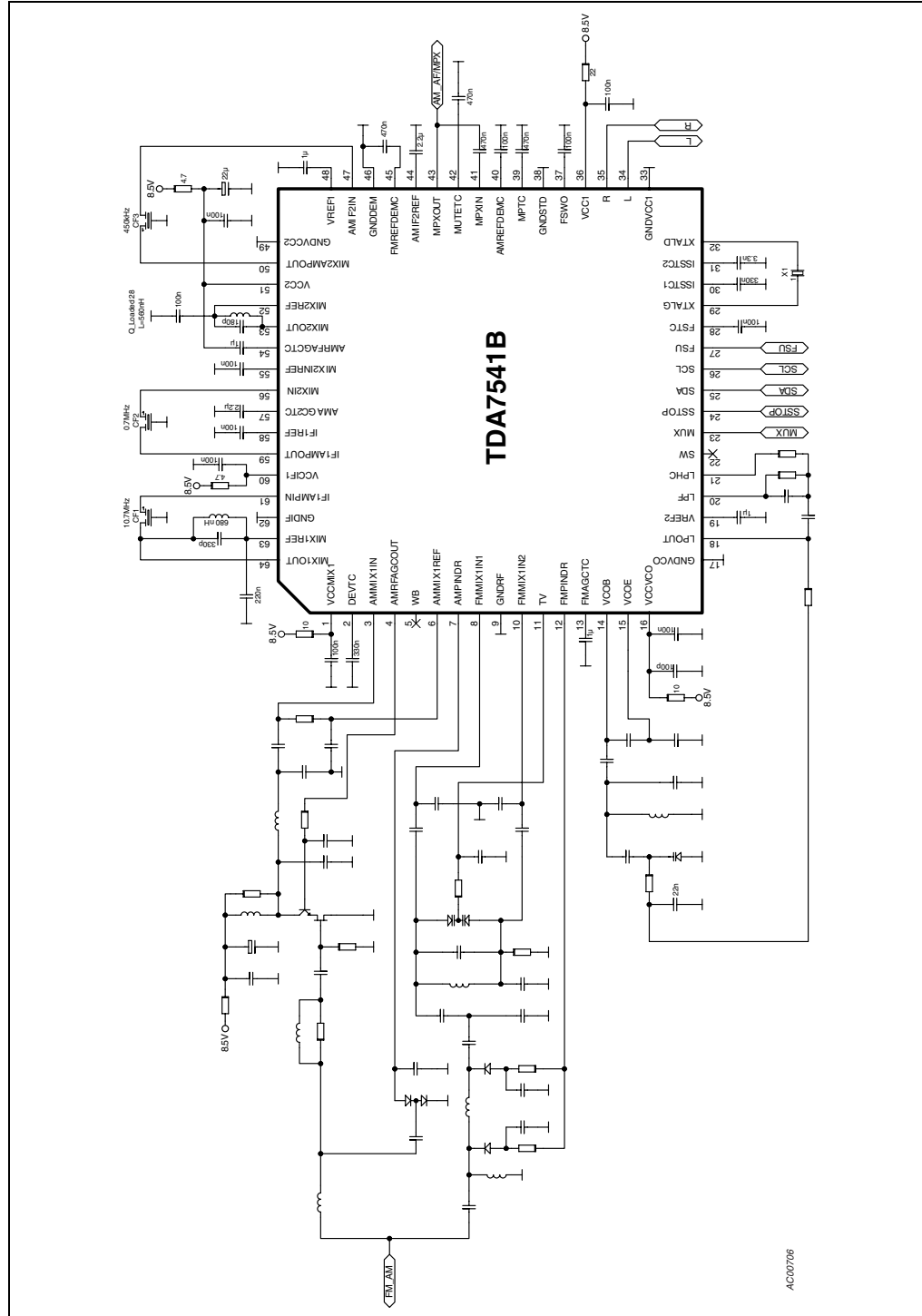

Figure 14. Block diagram multi path detection for stereo decoder



# 7 Application circuit

Figure 15. Application circuit



## 8 Package information

In order to meet environmental requirements, ST offers these devices in different grades of ECOPACK® packages, depending on their level of environmental compliance. ECOPACK® specifications, grade definitions and product status are available at: [www.st.com](http://www.st.com).

ECOPACK® is an ST trademark.

**Figure 16. LQFP64 mechanical data and package dimensions**

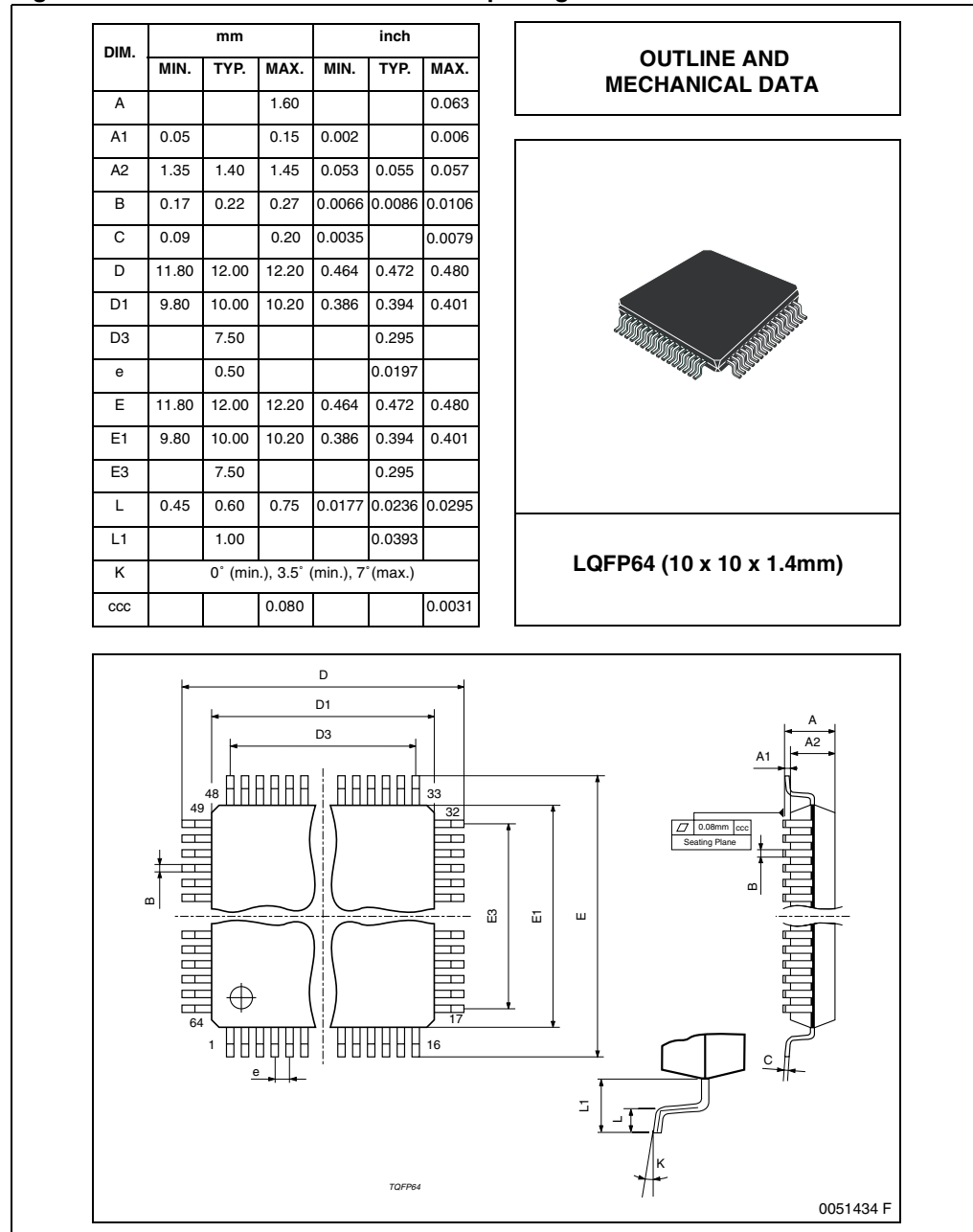

## 9 Revision history

Table 43. Document revision history

Date	Revision	Changes
22-Jul-2009	1	Initial release.

**Please Read Carefully:**

Information in this document is provided solely in connection with ST products. STMicroelectronics NV and its subsidiaries ("ST") reserve the right to make changes, corrections, modifications or improvements, to this document, and the products and services described herein at any time, without notice.

All ST products are sold pursuant to ST's terms and conditions of sale.

Purchasers are solely responsible for the choice, selection and use of the ST products and services described herein, and ST assumes no liability whatsoever relating to the choice, selection or use of the ST products and services described herein.

No license, express or implied, by estoppel or otherwise, to any intellectual property rights is granted under this document. If any part of this document refers to any third party products or services it shall not be deemed a license grant by ST for the use of such third party products or services, or any intellectual property contained therein or considered as a warranty covering the use in any manner whatsoever of such third party products or services or any intellectual property contained therein.

**UNLESS OTHERWISE SET FORTH IN ST'S TERMS AND CONDITIONS OF SALE ST DISCLAIMS ANY EXPRESS OR IMPLIED WARRANTY WITH RESPECT TO THE USE AND/OR SALE OF ST PRODUCTS INCLUDING WITHOUT LIMITATION IMPLIED WARRANTIES OF MERCHANTABILITY, FITNESS FOR A PARTICULAR PURPOSE (AND THEIR EQUIVALENTS UNDER THE LAWS OF ANY JURISDICTION), OR INFRINGEMENT OF ANY PATENT, COPYRIGHT OR OTHER INTELLECTUAL PROPERTY RIGHT.**

**UNLESS EXPRESSLY APPROVED IN WRITING BY AN AUTHORIZED ST REPRESENTATIVE, ST PRODUCTS ARE NOT RECOMMENDED, AUTHORIZED OR WARRANTED FOR USE IN MILITARY, AIR CRAFT, SPACE, LIFE SAVING, OR LIFE SUSTAINING APPLICATIONS, NOR IN PRODUCTS OR SYSTEMS WHERE FAILURE OR MALFUNCTION MAY RESULT IN PERSONAL INJURY, DEATH, OR SEVERE PROPERTY OR ENVIRONMENTAL DAMAGE. ST PRODUCTS WHICH ARE NOT SPECIFIED AS "AUTOMOTIVE GRADE" MAY ONLY BE USED IN AUTOMOTIVE APPLICATIONS AT USER'S OWN RISK.**

Resale of ST products with provisions different from the statements and/or technical features set forth in this document shall immediately void any warranty granted by ST for the ST product or service described herein and shall not create or extend in any manner whatsoever, any liability of ST.

ST and the ST logo are trademarks or registered trademarks of ST in various countries.

Information in this document supersedes and replaces all information previously supplied.

The ST logo is a registered trademark of STMicroelectronics. All other names are the property of their respective owners.

© 2009 STMicroelectronics - All rights reserved

STMicroelectronics group of companies

Australia - Belgium - Brazil - Canada - China - Czech Republic - Finland - France - Germany - Hong Kong - India - Israel - Italy - Japan - Malaysia - Malta - Morocco - Philippines - Singapore - Spain - Sweden - Switzerland - United Kingdom - United States of America

[www.st.com](http://www.st.com)

