

Features

- Super Heterodyne Radio Receiver
- CMOS / TTL Output
- Stable Operating Frequency
- 5Vdc Operating Voltage
- ASK Demodulation
- Low Power Consumption
- Available as 315 or 433 MHz

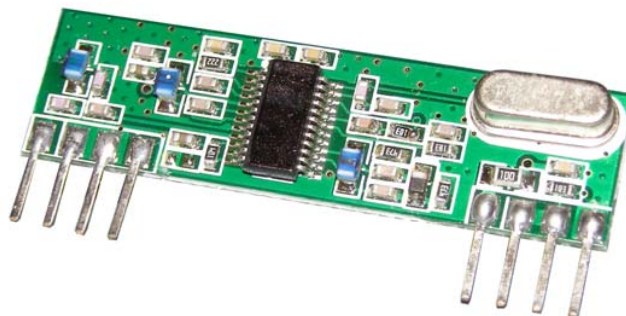

Applications

- Car Security Systems
- Automation Systems
- Remote Gate Controls
- Remote Sensing
- Data Capture
- Sensor Reporting

Description

The Quasar UK AM-RX4 Super Heterodyne receiver module provides a complete Radio receiver which can be used to receive undecoded data from the range of Quasar (UK) transmitter modules.

The module is very simple to operate and offers low power consumption allowing for extended battery life without the need to power down the module.

Data can be fed directly into a microprocessor or decoding device, thus keeping the component count down and ensuring a low hardware cost.

All receivers are compatible, producing a CMOS/TTL output, and only require connections to power and antenna.

Part Numbers

Part Number	Description
QAM-RX4-433	AM Super Heterodyne Receiver Module, 433MHz
QAM-RX4-315	AM Super Heterodyne Receiver Module, 315MHz

Technical Specifications Pin Descriptions

Pin	Description
1	External Antenna
2, 3, 8	Ground
4,5	Supply Voltage
6, 7	Data input

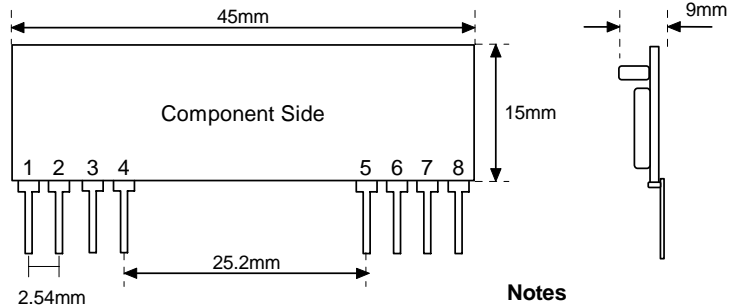

Notes
Pins on 0.1" pitch
Pin Dims :0.25 x 0.50mm

Electrical Characteristics

Ambient temp = 25°C unless otherwise stated.

Characteristic	Min.	Typ.	Max.	Dimensions
Supply Voltage		5		Vdc
Supply Current		2.3	3	mA
RF Sensitivity		-105		dBm
Working Frequency		315 / 433.92		MHz
High Level Output	0.7Vcc			VDC
Low Level Output			0.3Vcc	VDC
Turn On Time	25	30		ms
Data Rate	300	1,000	3,000	Hz
Operating Temperature	-10		+60	°C
Output Duty	40		60	%

Typical Application

For further information on this circuit please refer to the RF Solutions datasheet DS600

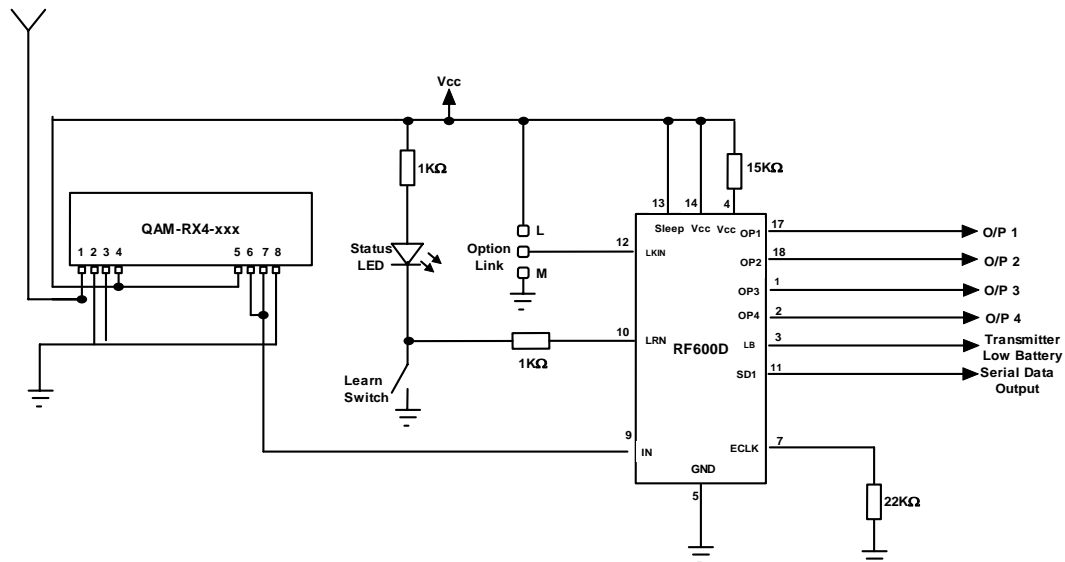

www.quasaruk.co.uk

Information contained in this document is believed to be accurate, however no representation or warranty is given and no liability is assumed by Quasar (UK) Ltd. with respect to the accuracy of such information. Use of products as critical components in life support systems is not authorised except with express written approval from Quasar (UK) Ltd.