

### Description

The Si4312 is a fully-integrated OOK CMOS RF receiver that operates in the unlicensed 315 and 433.92 MHz ultra high frequency (UHF) bands. It is designed for high-volume, cost-sensitive RF receiver applications. The chip operates at a carrier frequency of 315 or 433.92 MHz and supports OOK digital modulation with data rates of up to 10 kBaud NRZ or 5 kBaud Manchester coded. The Si4312 has selectable data filters to optimize the sensitivity of the receiver for a given data rate. The Si4312 employs a frequency scanning algorithm to improve the sensitivity of the receiver with a small IF bandwidth while still maintaining the ability to accommodate large transmit frequency offsets. The integrated on-chip squelch circuit prevents false output data when the RF input signal is absent or below sensitivity.

The device leverages Silicon Labs' patented and proven digital low-IF architecture and offers superior sensitivity and interference rejection. The Si4312 can achieve superior sensitivity in the presence of large interference due to its high dynamic range ADCs and digital filters. The digital low-IF architecture also enables superior blocking ability and low intermodulation distortion for robust reception in the presence of wide-band interference.

Digital integration reduces the number of required external components compared to traditional offerings, resulting in a solution that only requires a 16 MHz crystal and passive components allowing a small and compact printed circuit board (PCB) implementation area. The high integration of the Si4312 improves the system manufacturing reliability, improves quality, eases design-in, and minimizes costs.

### Features

- Single chip receiver with only six external components
- Selectable 315/433.92 MHz carrier frequency
- Supports OOK modulation
- High sensitivity (-110 dBm @ 1.0 kBaud)
- Frequency scanning
- Excellent interference rejection
- Data rates up to 10 kBaud NRZ (5 kBaud Manchester)
- Direct battery operation with on-chip low drop out (LDO) voltage regulator
- 16 MHz crystal oscillator support
- 3x3x0.85 mm 20L QFN package (RoHS compliant)
- -40 to +85 °C temperature range

### Applications

- Satellite set-top box receivers
- Remote controls, IR replacement/extension
- Garage and gate door openers
- Home automation and security
- Remote keyless entry
- After market alarms
- Telemetry
- Wireless point of sale
- Toys

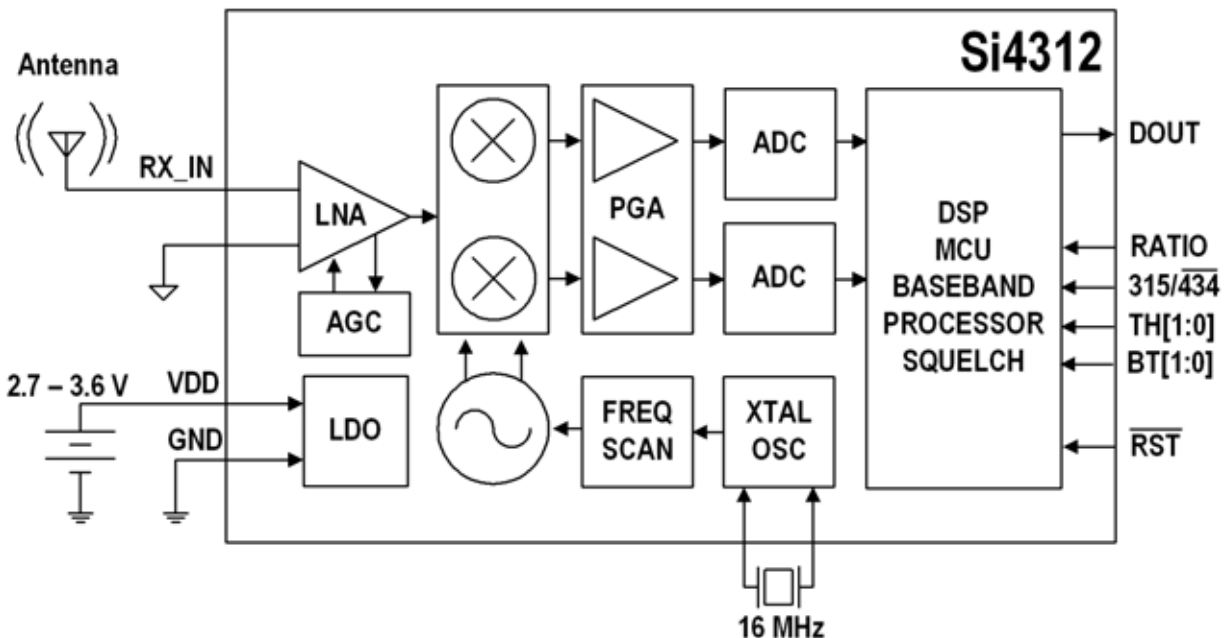

### Selected Electrical Specifications

Parameter	Symbol	Test Condition	Min	Typ	Max	Unit
Supply Voltage	$V_{DD}$		2.7	3.3	3.6	V
Ambient Temperature	$T_A$		-40	25	85	°C
Supply Current	$I_{VDD}$		—	20	—	mA
Reset Supply Current	$I_{RST}$	Reset asserted	—	2	—	μA
Sensitivity @ BER = $10^{-3}$		1.0 kBaud, 315 MHz	—	-110	—	dBm
		10 kBaud, 315 MHz	—	-103	—	dBm
		1.0 kBaud, 433.92 MHz	—	-106	—	dBm
		10 kBaud, 433.92 MHz	—	-101	—	dBm
Data Rate		NRZ	—	—	10	kBaud
Blocking		±2 MHz, 1.0 kBaud, desired signal is 3 dB above sensitivity, CW interferer level is increased until BER = $10^{-3}$	—	65	—	dB
		±10 MHz, 1.0 kBaud, desired signal is 3 dB above sensitivity, CW interferer level is increased until BER = $10^{-3}$	—	70	—	dB
Maximum RF Input Power			—	8	—	dBm
Input IP3		$ f_2 - f_1  = 5$ MHz, high gain mode, desired signal is 3 dB above sensitivity, CW interference levels are increased until BER = $10^{-3}$	—	-10	—	dBm
Crystal Oscillator Frequency			—	16	—	MHz

### Pin Package

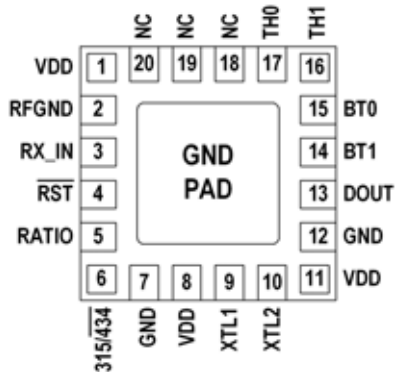

Symbol	Min	Nom	Max
A	0.80	0.85	0.90
A1	0.00	0.02	0.05
b	0.20	0.25	0.30
c	0.27	0.32	0.37
D	3.00 BSC		
D2	1.65	1.70	1.75
e	0.50 BSC		
E	3.00 BSC		
E2	1.65	1.70	1.75

Symbol	Min	Nom	Max
f	2.53 BSC		
L	0.30	0.35	0.40
L1	0.00	—	0.10
aaa	—	—	0.05
bbb	—	—	0.05
ccc	—	—	0.08
ddd	—	—	0.10
eee	—	—	0.10

#### Notes:

- All dimensions are shown in millimeters (mm) unless otherwise noted.
- Dimensioning and tolerancing per ASME Y14.5M-1994.

