

Gilbert Cell UHF Transistor Array

The HFA3101 is an all NPN transistor array configured as a Multiplier Cell. Based on Intersil's bonded wafer UHF-1 SOI process, this array achieves very high f_T (10GHz) while maintaining excellent h_{FE} and V_{BE} matching characteristics that have been maximized through careful attention to circuit design and layout, making this product ideal for communication circuits. For use in mixer applications, the cell provides high gain and good cancellation of 2nd order distortion terms.

Ordering Information

PART NUMBER (BRAND)	TEMP. RANGE (°C)	PACKAGE	PKG. DWG. #
HFA3101B (H3101B)	-40 to 85	8 Ld SOIC	M8.15
HFA3101BZ (H3101B) (Note)	-40 to 85	8 Ld SOIC (Pb-free)	M8.15
HFA3101B96 (H3101B)	-40 to 85	8 Ld SOIC Tape and Reel	M8.15
HFA3101BZ96 (H3101B) (Note)	-40 to 85	8 Ld SOIC Tape and Reel (Pb-free)	M8.15

NOTE: Intersil Pb-free products employ special Pb-free material sets; molding compounds/die attach materials and 100% matte tin plate termination finish, which is compatible with both SnPb and Pb-free soldering operations. Intersil Pb-free products are MSL classified at Pb-free peak reflow temperatures that meet or exceed the Pb-free requirements of IPC/JEDEC J STD-020C.

Pinout

HFA3101 (SOIC) TOP VIEW

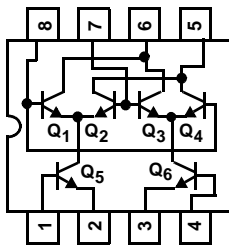

NOTE: Q₅ and Q₆ - 2 Paralleled 3μm x 50μm Transistors
 Q₁, Q₂, Q₃, Q₄ - Single 3μm x 50μm Transistors

Features

- Pb-free Available as an Option
- High Gain Bandwidth Product (f_T) 10GHz
- High Power Gain Bandwidth Product 5GHz
- Current Gain (h_{FE}) 70
- Low Noise Figure (Transistor) 3.5dB
- Excellent h_{FE} and V_{BE} Matching
- Low Collector Leakage Current <0.01nA
- Pin to Pin Compatible to UPA101

Applications

- Balanced Mixers
- Multipliers
- Demodulators/Modulators
- Automatic Gain Control Circuits
- Phase Detectors
- Fiber Optic Signal Processing
- Wireless Communication Systems
- Wide Band Amplification Stages
- Radio and Satellite Communications
- High Performance Instrumentation

Absolute Maximum Ratings

V_{CEO} , Collector to Emitter Voltage	8.0V
V_{CBO} , Collector to Base Voltage	12.0V
V_{EBO} , Emitter to Base Voltage	5.5V
I_C , Collector Current	30mA

Operating Conditions

Temperature Range -40°C to 85°C

Thermal Information

Thermal Resistance (Typical, Note 1)	θ_{JA} (°C/W)
SOIC Package	185
Maximum Junction Temperature (Die)	175°C
Maximum Junction Temperature (Plastic Package)	150°C
Maximum Storage Temperature Range	-65°C to 150°C
Maximum Lead Temperature (Soldering 10s)	300°C (SOIC - Lead Tips Only)

CAUTION: Stresses above those listed in "Absolute Maximum Ratings" may cause permanent damage to the device. This is a stress only rating and operation of the device at these or any other conditions above those indicated in the operational sections of this specification is not implied.

NOTE:

- θ_{JA} is measured with the component mounted on an evaluation PC board in free air.

Electrical Specifications $T_A = 25^\circ\text{C}$

PARAMETER	TEST CONDITIONS	(NOTE 2) TEST LEVEL	MIN	TYP	MAX	UNITS	
Collector to Base Breakdown Voltage, $V_{(BR)CBO}$, Q ₁ thru Q ₆	$I_C = 100\mu\text{A}$, $I_E = 0$	A	12	18	-	V	
Collector to Emitter Breakdown Voltage, $V_{(BR)CEO}$, Q ₅ and Q ₆	$I_C = 100\mu\text{A}$, $I_B = 0$	A	8	12	-	V	
Emitter to Base Breakdown Voltage, $V_{(BR)EBO}$, Q ₁ thru Q ₆	$I_E = 10\mu\text{A}$, $I_C = 0$	A	5.5	6	-	V	
Collector Cutoff Current, I_{CBO} , Q ₁ thru Q ₄	$V_{CB} = 8\text{V}$, $I_E = 0$	A	-	0.1	10	nA	
Emitter Cutoff Current, I_{EBO} , Q ₅ and Q ₆	$V_{EB} = 1\text{V}$, $I_C = 0$	A	-	-	200	nA	
DC Current Gain, h_{FE} , Q ₁ thru Q ₆	$I_C = 10\text{mA}$, $V_{CE} = 3\text{V}$	A	40	70	-		
Collector to Base Capacitance, C_{CB}	$V_{CB} = 5\text{V}$, $f = 1\text{MHz}$	C	Q ₁ thru Q ₄	0.300	-	pF	
			Q ₅ and Q ₆	0.600	-	pF	
Emitter to Base Capacitance, C_{EB}	$V_{EB} = 0$, $f = 1\text{MHz}$	B	Q ₁ thru Q ₄	0.200	-	pF	
			Q ₅ and Q ₆	0.400	-	pF	
Current Gain-Bandwidth Product, f_T	Q ₁ thru Q ₄	C	-	10	-	GHz	
	Q ₅ and Q ₆	C	-	10	-	GHz	
Power Gain-Bandwidth Product, f_{MAX}	Q ₁ thru Q ₄	C	-	5	-	GHz	
	Q ₅ and Q ₆	C	-	5	-	GHz	
Available Gain at Minimum Noise Figure, G_{NFMIN} , Q ₅ and Q ₆	$I_C = 5\text{mA}$, $V_{CE} = 3\text{V}$	$f = 0.5\text{GHz}$	C	-	17.5	-	dB
		$f = 1.0\text{GHz}$	C	-	11.9	-	dB
Minimum Noise Figure, NF_{MIN} , Q ₅ and Q ₆	$I_C = 5\text{mA}$, $V_{CE} = 3\text{V}$	$f = 0.5\text{GHz}$	C	-	1.7	-	dB
		$f = 1.0\text{GHz}$	C	-	2.0	-	dB
50Ω Noise Figure, $NF_{50\Omega}$, Q ₅ and Q ₆	$I_C = 5\text{mA}$, $V_{CE} = 3\text{V}$	$f = 0.5\text{GHz}$	C	-	2.25	-	dB
		$f = 1.0\text{GHz}$	C	-	2.5	-	dB
DC Current Gain Matching, h_{FE1}/h_{FE2} , Q ₁ and Q ₂ , Q ₃ and Q ₄ , and Q ₅ and Q ₆	$I_C = 10\text{mA}$, $V_{CE} = 3\text{V}$	A	0.9	1.0	1.1		
Input Offset Voltage, V_{OS} , (Q ₁ and Q ₂), (Q ₃ and Q ₄), (Q ₅ and Q ₆)	$I_C = 10\text{mA}$, $V_{CE} = 3\text{V}$	A	-	1.5	5	mV	
Input Offset Current, I_C , (Q ₁ and Q ₂), (Q ₃ and Q ₄), (Q ₅ and Q ₆)	$I_C = 10\text{mA}$, $V_{CE} = 3\text{V}$	A	-	5	25	μA	
Input Offset Voltage TC, dV_{OS}/dT , (Q ₁ and Q ₂ , Q ₃ and Q ₄ , Q ₅ and Q ₆)	$I_C = 10\text{mA}$, $V_{CE} = 3\text{V}$	C	-	0.5	-	μV/°C	
Collector to Collector Leakage, $I_{TRENCH-LEAKAGE}$	$\Delta V_{TEST} = 5\text{V}$	B	-	0.01	-	nA	

NOTE:

- Test Level: A. Production Tested, B. Typical or Guaranteed Limit Based on Characterization, C. Design Typical for Information Only.

PSPICE Model for a 3μm x 50μm Transistor

.Model NUHFARRY NPN

+ (IS = 1.840E-16	XTI = 3.000E+00	EG = 1.110E+00	VAF = 7.200E+01
+ VAR = 4.500E+00	BF = 1.036E+02	ISE = 1.686E-19	NE = 1.400E+00
+ IKF = 5.400E-02	XTB = 0.000E+00	BR = 1.000E+01	ISC = 1.605E-14
+ NC = 1.800E+00	IKR = 5.400E-02	RC = 1.140E+01	CJC = 3.980E-13
+ MJC = 2.400E-01	VJC = 9.700E-01	FC = 5.000E-01	CJE = 2.400E-13
+ MJE = 5.100E-01	VJE = 8.690E-01	TR = 4.000E-09	TF = 10.51E-12
+ ITF = 3.500E-02	XTF = 2.300E+00	VTF = 3.500E+00	PTF = 0.000E+00
+ XCJC = 9.000E-01	CJS = 1.689E-13	VJS = 9.982E-01	MJS = 0.000E+00
+ RE = 1.848E+00	RB = 5.007E+01	RBM = 1.974E+00	KF = 0.000E+00
+ AF = 1.000E+00)			

Common Emitter S-Parameters of 3μm x 50μm Transistor

FREQ. (Hz)	S ₁₁	PHASE(S ₁₁)	S ₁₂	PHASE(S ₁₂)	S ₂₁	PHASE(S ₂₁)	S ₂₂	PHASE(S ₂₂)
V_{CE} = 5V and I_C = 5mA								
1.0E+08	0.83	-11.78	1.41E-02	78.88	11.07	168.57	0.97	-11.05
2.0E+08	0.79	-22.82	2.69E-02	68.63	10.51	157.89	0.93	-21.35
3.0E+08	0.73	-32.64	3.75E-02	59.58	9.75	148.44	0.86	-30.44
4.0E+08	0.67	-41.08	4.57E-02	51.90	8.91	140.36	0.79	-38.16
5.0E+08	0.61	-48.23	5.19E-02	45.50	8.10	133.56	0.73	-44.59
6.0E+08	0.55	-54.27	5.65E-02	40.21	7.35	127.88	0.67	-49.93
7.0E+08	0.50	-59.41	6.00E-02	35.82	6.69	123.10	0.62	-54.37
8.0E+08	0.46	-63.81	6.27E-02	32.15	6.11	119.04	0.57	-58.10
9.0E+08	0.42	-67.63	6.47E-02	29.07	5.61	115.57	0.53	-61.25
1.0E+09	0.39	-70.98	6.63E-02	26.45	5.17	112.55	0.50	-63.96
1.1E+09	0.36	-73.95	6.75E-02	24.19	4.79	109.91	0.47	-66.31
1.2E+09	0.34	-76.62	6.85E-02	22.24	4.45	107.57	0.45	-68.37
1.3E+09	0.32	-79.04	6.93E-02	20.53	4.15	105.47	0.43	-70.19
1.4E+09	0.30	-81.25	7.00E-02	19.02	3.89	103.57	0.41	-71.83
1.5E+09	0.28	-83.28	7.05E-02	17.69	3.66	101.84	0.40	-73.31
1.6E+09	0.27	-85.17	7.10E-02	16.49	3.45	100.26	0.39	-74.66
1.7E+09	0.25	-86.92	7.13E-02	15.41	3.27	98.79	0.38	-75.90
1.8E+09	0.24	-88.57	7.17E-02	14.43	3.10	97.43	0.37	-77.05
1.9E+09	0.23	-90.12	7.19E-02	13.54	2.94	96.15	0.36	-78.12
2.0E+09	0.22	-91.59	7.21E-02	12.73	2.80	94.95	0.35	-79.13
2.1E+09	0.21	-92.98	7.23E-02	11.98	2.68	93.81	0.35	-80.09
2.2E+09	0.20	-94.30	7.25E-02	11.29	2.56	92.73	0.34	-80.99
2.3E+09	0.20	-95.57	7.27E-02	10.64	2.45	91.70	0.34	-81.85
2.4E+09	0.19	-96.78	7.28E-02	10.05	2.35	90.72	0.33	-82.68
2.5E+09	0.18	-97.93	7.29E-02	9.49	2.26	89.78	0.33	-83.47
2.6E+09	0.18	-99.05	7.30E-02	8.96	2.18	88.87	0.33	-84.23
2.7E+09	0.17	-100.12	7.31E-02	8.47	2.10	88.00	0.33	-84.97

HFA3101

Common Emitter S-Parameters of 3 μ m x 50 μ m Transistor (Continued)

FREQ. (Hz)	S ₁₁	PHASE(S ₁₁)	S ₁₂	PHASE(S ₁₂)	S ₂₁	PHASE(S ₂₁)	S ₂₂	PHASE(S ₂₂)
2.8E+09	0.17	-101.15	7.31E-02	8.01	2.02	87.15	0.33	-85.68
2.9E+09	0.16	-102.15	7.32E-02	7.57	1.96	86.33	0.33	-86.37
3.0E+09	0.16	-103.11	7.32E-02	7.16	1.89	85.54	0.33	-87.05
V_{CE} = 5V and I_C = 10mA								
1.0E+08	0.72	-16.43	1.27E-02	75.41	15.12	165.22	0.95	-14.26
2.0E+08	0.67	-31.26	2.34E-02	62.89	13.90	152.04	0.88	-26.95
3.0E+08	0.60	-43.76	3.13E-02	52.58	12.39	141.18	0.79	-37.31
4.0E+08	0.53	-54.00	3.68E-02	44.50	10.92	132.57	0.70	-45.45
5.0E+08	0.47	-62.38	4.05E-02	38.23	9.62	125.78	0.63	-51.77
6.0E+08	0.42	-69.35	4.31E-02	33.34	8.53	120.37	0.57	-56.72
7.0E+08	0.37	-75.26	4.49E-02	29.47	7.62	116.00	0.51	-60.65
8.0E+08	0.34	-80.36	4.63E-02	26.37	6.86	112.39	0.47	-63.85
9.0E+08	0.31	-84.84	4.72E-02	23.84	6.22	109.36	0.44	-66.49
1.0E+09	0.29	-88.83	4.80E-02	21.75	5.69	106.77	0.41	-68.71
1.1E+09	0.27	-92.44	4.86E-02	20.00	5.23	104.51	0.39	-70.62
1.2E+09	0.25	-95.73	4.90E-02	18.52	4.83	102.53	0.37	-72.28
1.3E+09	0.24	-98.75	4.94E-02	17.25	4.49	100.75	0.35	-73.76
1.4E+09	0.22	-101.55	4.97E-02	16.15	4.19	99.16	0.34	-75.08
1.5E+09	0.21	-104.15	4.99E-02	15.19	3.93	97.70	0.33	-76.28
1.6E+09	0.20	-106.57	5.01E-02	14.34	3.70	96.36	0.32	-77.38
1.7E+09	0.20	-108.85	5.03E-02	13.60	3.49	95.12	0.31	-78.41
1.8E+09	0.19	-110.98	5.05E-02	12.94	3.30	93.96	0.31	-79.37
1.9E+09	0.18	-113.00	5.06E-02	12.34	3.13	92.87	0.30	-80.27
2.0E+09	0.18	-114.90	5.07E-02	11.81	2.98	91.85	0.30	-81.13
2.1E+09	0.17	-116.69	5.08E-02	11.33	2.84	90.87	0.30	-81.95
2.2E+09	0.17	-118.39	5.09E-02	10.89	2.72	89.94	0.29	-82.74
2.3E+09	0.16	-120.01	5.10E-02	10.50	2.60	89.06	0.29	-83.50
2.4E+09	0.16	-121.54	5.11E-02	10.13	2.49	88.21	0.29	-84.24
2.5E+09	0.16	-122.99	5.12E-02	9.80	2.39	87.39	0.29	-84.95
2.6E+09	0.15	-124.37	5.12E-02	9.49	2.30	86.60	0.29	-85.64
2.7E+09	0.15	-125.69	5.13E-02	9.21	2.22	85.83	0.29	-86.32
2.8E+09	0.15	-126.94	5.13E-02	8.95	2.14	85.09	0.29	-86.98
2.9E+09	0.15	-128.14	5.14E-02	8.71	2.06	84.36	0.29	-87.62
3.0E+09	0.14	-129.27	5.15E-02	8.49	1.99	83.66	0.29	-88.25

Application Information

The HFA3101 array is a very versatile RF Building block. It has been carefully laid out to improve its matching properties, bringing the distortion due to area mismatches, thermal distribution, betas and ohmic resistances to a minimum.

The cell is equivalent to two differential stages built as two “variable transconductance multipliers” in parallel, with their outputs cross coupled. This configuration is well known in the industry as a Gilbert Cell which enables a four quadrant multiplication operation.

Due to the input dynamic range restrictions for the input levels at the upper quad transistors and lower tail transistors, the HFA3101 cell has restricted use as a linear four quadrant multiplier. However, its configuration is well suited for uses where its linear response is limited to one of the inputs only, as in modulators or mixer circuit applications. Examples of these circuits are up converters, down converters, frequency doublers and frequency/phase detectors.

Although linearization is still an issue for the lower pair input, emitter degeneration can be used to improve the dynamic range and consequent linearity. The HFA3101 has the lower pair emitters brought to external pins for this purpose.

In modulators applications, the upper quad transistors are used in a switching mode where the pairs Q_1/Q_2 and Q_3/Q_4 act as non saturating high speed switches. These switches are controlled by the signal often referred as the carrier input. The signal driving the lower pair Q_5/Q_6 is commonly used as the modulating input. This signal can be linearly transferred to the output by either the use of low signal levels (Well below the thermal voltage of 26mV) or by the use of emitter degeneration. The chopped waveform appearing at the output of the upper pair (Q_1 to Q_4) resembles a signal that is multiplied by +1 or -1 at every half cycle of the switching waveform.

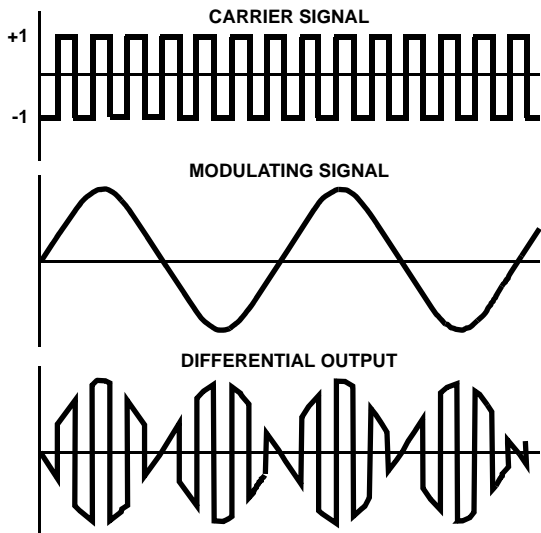

FIGURE 1. TYPICAL MODULATOR SIGNALS

Figure 1 shows the typical input waveforms where the frequency of the carrier is higher than the modulating signal. The output waveform shows a typical suppressed carrier output of an up converter or an AM signal generator.

Carrier suppression capability is a property of the well known Balanced modulator in which the output must be zero when one or the other input (carrier or modulating signal) is equal to zero. However, at very high frequencies, high frequency mismatches and AC offsets are always present and the suppression capability is often degraded causing carrier and modulating feedthrough to be present.

Being a frequency translation circuit, the balanced modulator has the properties of translating the modulating frequency (ω_M) to the carrier frequency (ω_C), generating the two side bands $\omega_U = \omega_C + \omega_M$ and $\omega_L = \omega_C - \omega_M$. Figure 2 shows some translating schemes being used by balanced mixers.

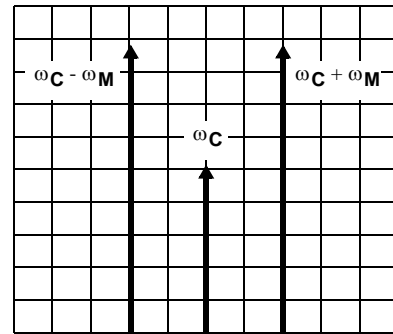

FIGURE 2A. UP CONVERSION OR SUPPRESSED CARRIER AM

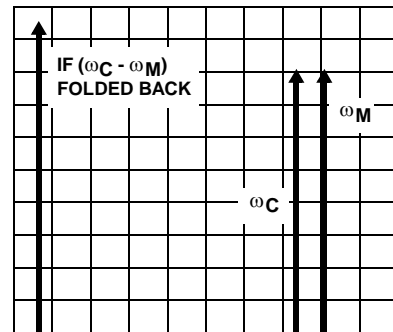

FIGURE 2B. DOWN CONVERSION

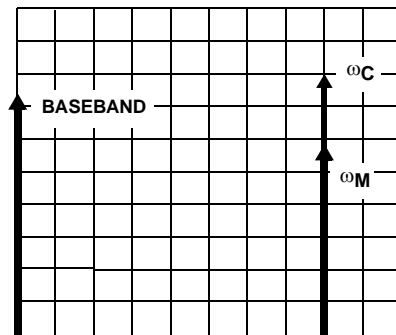

FIGURE 2C. ZERO IF OR DIRECT DOWN CONVERSION
FIGURE 2. MODULATOR FREQUENCY SPECTRUM

The use of the HFA3101 as modulators has several advantages when compared to its counterpart, the diode doublebalanced mixer, in which it is required to receive enough energy to drive the diodes into a switching mode and has also some requirements depending on the frequency range desired, of different transformers to suit specific frequency responses. The HFA3101 requires very low driving capabilities for its carrier input and its frequency response is limited by the f_T of the devices, the design and the layout techniques being utilized.

Up conversion uses, for UHF transmitters for example, can be performed by injecting a modulating input in the range of 45MHz to 130MHz that carries the information often called IF (Intermediate frequency) for up conversion (The IF signal has been previously modulated by some modulation scheme from a baseband signal of audio or digital information) and by injecting the signal of a local oscillator of a much higher frequency range from 600MHz to 1.2GHz into the carrier input. Using the example of a 850MHz carrier input and a 70MHz IF, the output spectrum will contain an upper side band of 920MHz, a lower side band of 780MHz and some of the carrier (850MHz) and IF (70MHz) feedthrough. A Band pass filter at the output can attenuate the undesirable signals and the 920MHz signal can be routed to a transmitter RF power amplifier.

Down conversion, as the name implies, is the process used to translate a higher frequency signal to a lower frequency range conserving the modulation information contained in the higher frequency signal. One very common typical down conversion use for example, is for superheterodyne radio receivers where a translated lower frequency often referred as intermediate frequency (IF) is used for detection or demodulation of the baseband signal. Other application uses include down conversion for special filtering using frequency translation methods.

An oscillator referred as the local oscillator (LO) drives the upper quad transistors of the cell with a frequency called ω_C . The lower pair is driven by the RF signal of frequency ω_M to be translated to a lower frequency IF. The spectrum of the IF output will contain the sum and difference of the frequencies ω_C and ω_M . Notice that the difference can become negative when the frequency of the local oscillator is lower than the incoming frequency and the signal is folded back as in Figure 2.

NOTE: The acronyms RF, IF and LO are often interchanged in the industry depending on the application of the cell as mixers or modulators. The output of the cell also contains multiples of the frequency of the signal being fed to the upper quad pair of transistors because of the switching action equivalent to a square wave multiplication. In practice, however, not only the odd multiples in the case of a symmetrical square wave but some of the even multiples will also appear at the output spectrum due to the nature of the actual switching waveform and high frequency performance. By-products of the form $M*\omega_C + N*\omega_M$ with M and N being positive or negative integers are also expected to be present at the output and their levels are carefully examined and minimized by the design. This distortion is considered one of the figures of merit for a mixer application.

The process of frequency doubling is also understood by having the same signal being fed to both modulating and carrier ports. The output frequency will be the sum of ω_C and ω_M which is equivalent to the product of the input frequency by 2 and a zero Hz or DC frequency equivalent to the difference of ω_C and ω_M . Figure 2 also shows one technique in use today where a process of down conversion named zero IF is made by using a local oscillator with a very pure signal frequency equal to the incoming RF frequency signal that contains a baseband (audio or digital signal) modulation. Although complex, the extraction or detection of the signal is straightforward.

Another useful application of the HFA3101 is its use as a high frequency phase detector where the two signals are fed to the carrier and modulation ports and the DC information is extracted from its output. In this case, both ports are utilized in a switching mode or overdrive, such that the process of multiplication takes place in a quasi digital form (2 square waves). One application of a phase detector is frequency or phase demodulation where the FM signal is split before the modulating and carrier ports. The lower input port is always 90 degrees apart from the carrier input signal through a high Q tuned phase shift network. The network, being tuned for a precise 90 degrees shift at a nominal frequency, will set the two signals 90 degrees apart and a quiescent output DC level will be present at the output. When the input signal is frequency modulated, the phase shift of the signal coming from the network will deviate from 90 degrees proportional to the frequency deviation of the FM signal and a DC variation at the output will take place, resembling the demodulated FM signal.

The HFA3101 could also be used for quadrature detection, (I/Q demodulation), AGC control with limited range, low level multiplication to name a few other applications.

Biassing

Various biasing schemes can be employed for use with the HFA3101. Figure 3 shows the most common schemes. The biasing method is a choice of the designer when cost, thermal dependence, voltage overheads and DC balancing properties are taken into consideration.

Figure 3A shows the simplest form of biasing the HFA3101. The current source required for the lower pair is set by the voltage across the resistor R_{BIAS} less a V_{BE} drop of the lower transistor. To increase the overhead, collector resistors are substituted by an RF choke as the upper pair functions as a current source for AC signals. The bases of the upper and lower transistors are biased by R_{B1} and R_{B2} respectively. The voltage drop across the resistor R_2 must be higher than a V_{BE} with an increase sufficient to assure that the collector to base junctions of the lower pair are always reverse biased. Notice that this same voltage also sets the V_{CE} of operation of the lower pair which is important for the optimization of gain. Resistors R_{EE} are nominally zero for applications where the input signals are well below 25mV peak. Resistors R_{EE} are used to increase the linearity

of the circuit upon higher level signals. The drop across R_{EE} must be taken into consideration when setting the current source value.

Figure 3B depicts the use of a common resistor sharing the current through the cell which is used for temperature

compensation as the lower pair V_{BE} drop at the rate of $-2mV/^{\circ}C$.

Figure 3C uses a split supply.

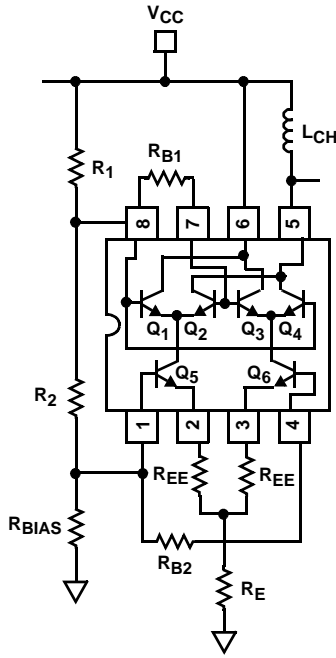

FIGURE 3A.

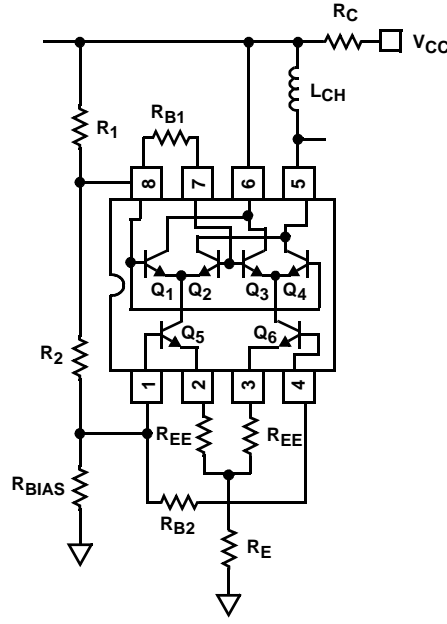

FIGURE 3B.

FIGURE 3.

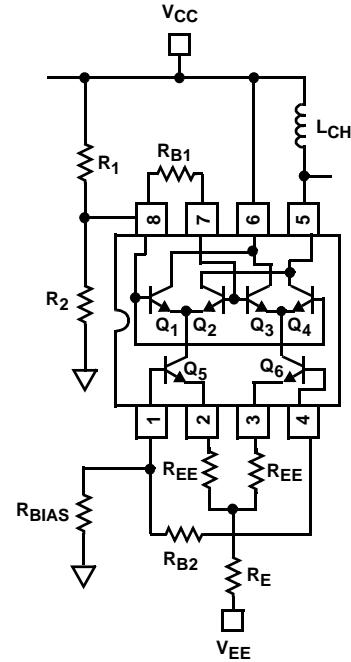

FIGURE 3C.

Design Example: Down Converter Mixer

Figure 4 shows an example of a low cost mixer for cellular applications.

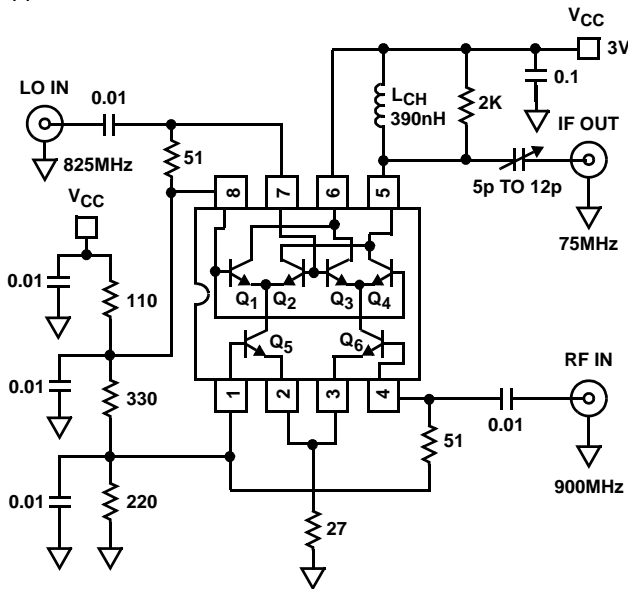

FIGURE 4. 3V DOWN CONVERTER APPLICATION

The design flexibility of the HFA3101 is demonstrated by a low cost, and low voltage mixer application at the 900MHz range. The choice of good quality chip components with their self resonance outside the boundaries of the application are important. The design has been optimized to accommodate the evaluation of the same layout for various quiescent current values and lower supply voltages. The choice of R_E became important for the available overhead and also for maintaining an AC true impedance for high frequency signals. The value of 27Ω has been found to be the optimum minimum for the application. The input impedances of the HFA3101 base input ports are high enough to permit their termination with 50Ω resistors. Notice the AC termination by decoupling the bias circuit through good quality capacitors.

The choice of the bias has been related to the available power supply voltage with the values of R_1 , R_2 and R_{BIAS} splitting the voltages for optimum V_{CE} values. For evaluation of the cell quiescent currents, the voltage at the emitter resistor R_E has been recorded.

The gain of the circuit, being a function of the load and the combined emitter resistances at high frequencies have been kept to a maximum by the use of an output match network. The high output impedance of the HFA3101 permits

broadband match if so desired at 50Ω ($R_L = 50\Omega$ to $2k\Omega$) as well as with tuned medium Q matching networks (L, T etc.).

Stability

The cell, by its nature, has very high gain and precautions must be taken to account for the combination of signal reflections, gain, layout and package parasitics. The rule of thumb of avoiding reflected waves must be observed. It is important to assure good matching between the mixer stage and its front end. Laboratory measurements have shown some susceptibility for oscillation at the upper quad transistors input. Any LO prefiltering has to be designed such the return loss is maintained within acceptable limits specially at high frequencies. Typical off the shelf filters exhibits very poor return loss for signals outside the passband. It is suggested that a “pad” or a broadband resistive network be used to interface the LO port with a filter. The inclusion of a parallel 2K resistor in the load decreases the gain slightly which improves the stability factor and also improves the distortion products (output intermodulation or 3rd order intercept). The employment of good RF techniques shall suffice the stability requirements.

Evaluation

The evaluation of the HFA3101 in a mixer configuration is presented in Figures 6 to 11, Table 1 and Table 2. The layout is depicted in Figure 5.

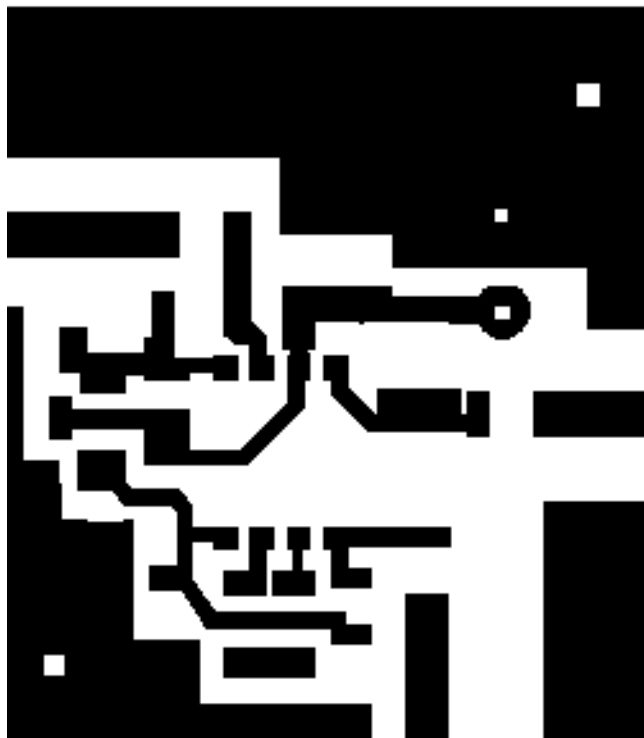

FIGURE 5. UP/DOWN CONVERTER LAYOUT, 400%; MATERIAL G10, 0.031

The output matching network has been designed from data taken at the output port at various test frequencies with the

setup as in Table 1. S_{22} characterization is enough to assure the calculation of L, T or transmission line matching networks.

TABLE 1. S_{22} PARAMETERS FOR DOWN CONVERSION, $L_{CH} = 10\mu H$

FREQUENCY	RESISTANCE	REACTANCE
10MHz	265 Ω	615 Ω
45MHz	420 Ω	- 735 Ω
75MHz	122 Ω	- 432 Ω
100MHz	67 Ω	- 320 Ω

TABLE 2. TYPICAL PARAMETERS FOR DOWN CONVERSION, $L_{CH} = 10\mu H$

PARAMETER	LO LEVEL	$V_{CC} = 3V,$ $I_{BIAS} = 8mA$
Power Gain	-6dBm	8.5dB
TOI Output	-6dBm	11.5dBm
NF SSB	-6dBm	14.5dB
Power Gain	0dBm	8.6dB
TOI Output	0dBm	11dBm
NF SSB	0dBm	15dB

PARAMETER	LO LEVEL	$V_{CC} = 4V,$ $I_{BIAS} = 19mA$
Power Gain	-6dBm	10dB
TOI Output	-6dBm	13dBm
NF SSB	-6dBm	20dB
Power Gain	0dBm	11dB
TOI Output	0dBm	12.5dBm
NF SSB	0dBm	24dB

TABLE 3. TYPICAL VALUES OF S_{22} FOR THE OUTPUT PORT. $L_{CH} = 390nH$ $I_{BIAS} = 8mA$ (SET UP OF FIGURE 11)

FREQUENCY	RESISTANCE	REACTANCE
300MHz	22 Ω	-115 Ω
600MHz	7.5 Ω	-43 Ω
900MHz	5.2 Ω	-14 Ω
1.1GHz	3.9 Ω	0 Ω

TABLE 4. TYPICAL VALUES OF S_{22} . $L_{CH} = 390nH$, $I_{BIAS} = 18mA$

FREQUENCY	RESISTANCE	REACTANCE
300MHz	23.5 Ω	-110 Ω
600MHz	10.3 Ω	-39 Ω
900MHz	8.7 Ω	-14 Ω
1.1GHz	8 Ω	0 Ω

Up Converter Example

An application for a up converter as well as a frequency multiplier can be demonstrated using the same layout, with an addition of matching components. The output port S_{22} must be characterized for proper matching procedures and depending on the frequency desired for the output, transmission line transformations can be designed. The return loss of the input ports maintain acceptable values in

excess of 1.2GHz which can permit the evaluation of a frequency doubler to 2.4GHz if so desired.

The addition of the resistors R_{EE} can increase considerably the dynamic range of the up converter as demonstrated at Figure 13. The evaluation results depicted in Table 5 have been obtained by a triple stub tuner as a matching network for the output due to the layout constraints. Based on the evaluation results it is clear that the cell requires a higher Bias current for overall performance.

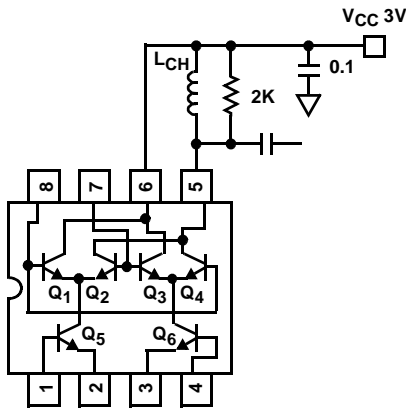

FIGURE 6. OUTPUT PORT S_{22} TEST SET UP

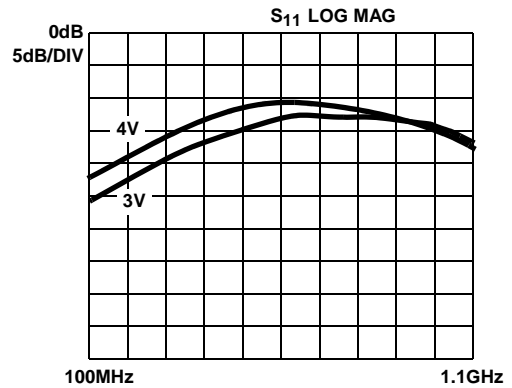

FIGURE 7. LO PORT RETURN LOSS

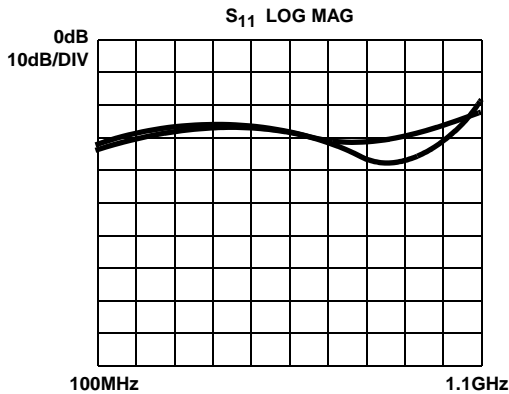

FIGURE 8. RF PORT RETURN LOSS

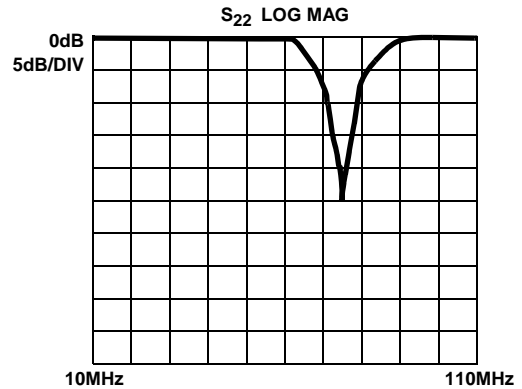

FIGURE 9. IF PORT RETURN LOSS, WITH MATCHING NETWORK

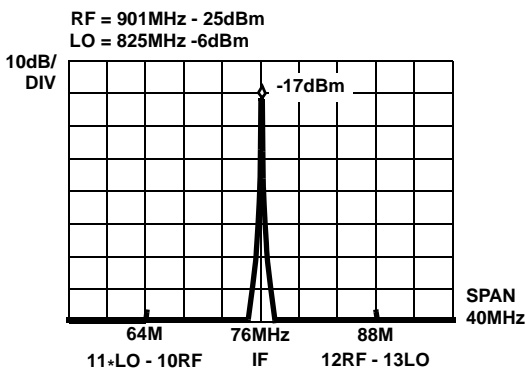

FIGURE 10. TYPICAL IN BAND OUTPUT SPECTRUM, $V_{CC} = 3V$

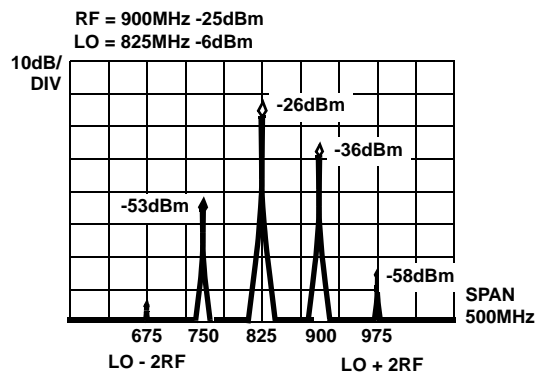

FIGURE 11. TYPICAL OUT OF BAND OUTPUT SPECTRUM

Design Example: Up Converter Mixer

Figure 12 shows an example of an up converter for cellular applications.

Conclusion

The HFA3101 offers the designer a number of choices and different applications as a powerful RF building block. Although isolation is degraded from the theoretical results for the cell due to the unbalanced, nondifferential input schemes being used, a number of advantages can be taken into consideration like cost, flexibility, low power and small outline when deciding for a design.

TABLE 5. TYPICAL PARAMETERS FOR THE UP CONVERTER EXAMPLE

PARAMETER	V _{CC} = 3V, I _{BIAS} = 8mA	V _{CC} = 4V, I _{BIAS} = 18mA
Power Gain, LO = -6dBm	3dB	5.5dBm
Power Gain, LO = 0dBm	4dB	7.2dB
RF Isolation, LO = 0dBm	15dBc	22dBc
LO Isolation, LO = 0dBm	28dBc	28dBc

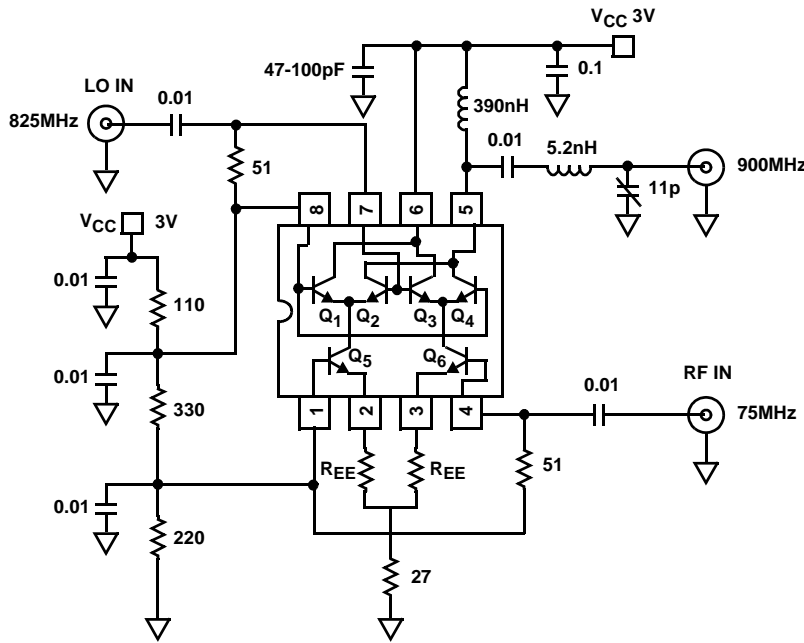
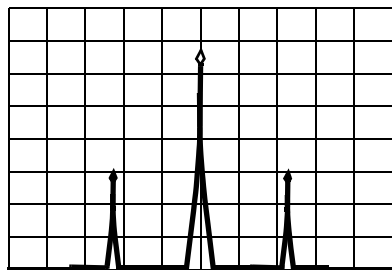

FIGURE 12. UP CONVERTER

OUTPUT WITHOUT EMITTER DEGENERATION



890 901 912
2LO - 10RF 12RF

RF = 76MHz
LO = 825MHz

OUTPUT WITH EMITTER DEGENERATION R_{EE} = 4.7Ω

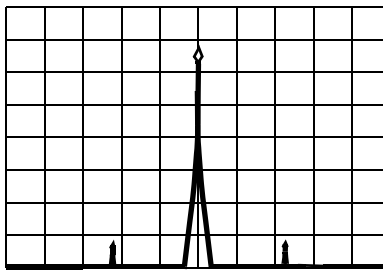

SPAN
50MHz

EXPANDED SPECTRUM R_{EE} = 4.7Ω

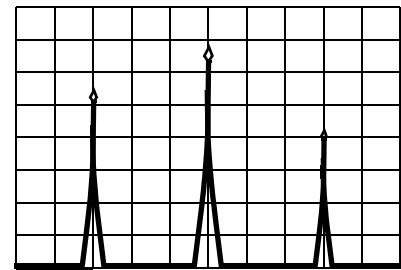

825 900 976

FIGURE 13. TYPICAL SPECTRUM PERFORMANCE OF UP CONVERTER

Typical Performance Curves for Transistors

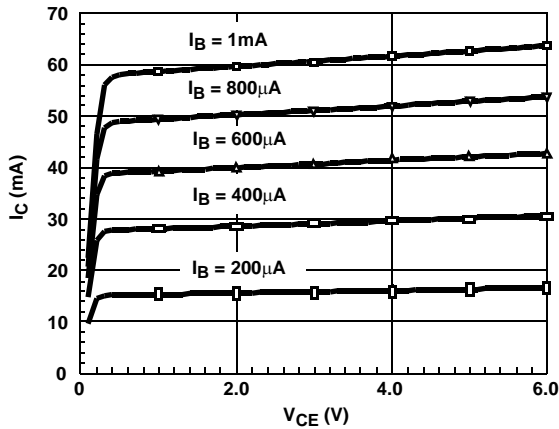

FIGURE 14. I_C vs V_{CE}

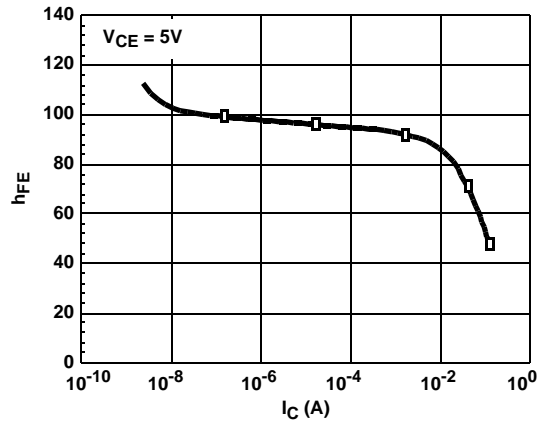

FIGURE 15. h_{FE} vs I_C

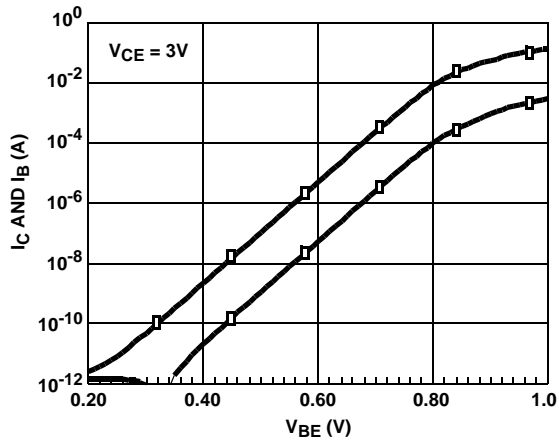

FIGURE 16. GUMMEL PLOT

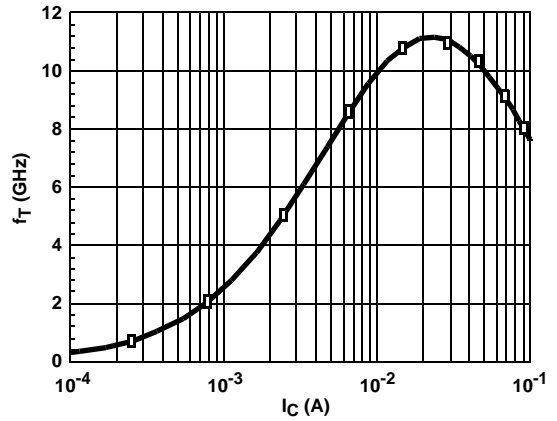

FIGURE 17. f_T vs I_C

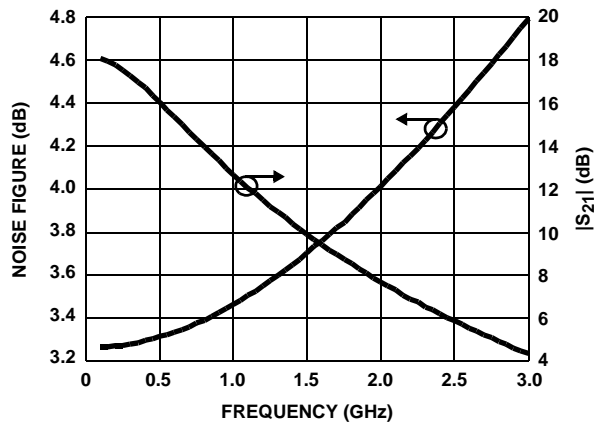

FIGURE 18. GAIN AND NOISE FIGURE vs FREQUENCY

NOTE: Figures 14 through 18 are only for Q₅ and Q₆.

HFA3101

Die Characteristics

PROCESS

UHF-1

DIE DIMENSIONS:

53 mils x 52 mils x 14 mils
1340 μ m x 1320 μ m x 355.6 μ m

METALLIZATION:

Type: Metal 1: AlCu(2%)/TiW
Thickness: Metal 1: 8k \AA \pm 0.5k \AA

Type: Metal 2: AlCu(2%)
Thickness: Metal 2: 16k \AA \pm 0.8k \AA

PASSIVATION:

Type: Nitride
Thickness: 4k \AA \pm 0.5k \AA

SUBSTRATE POTENTIAL (Powered Up):

Floating

Metallization Mask Layout

HFA3101

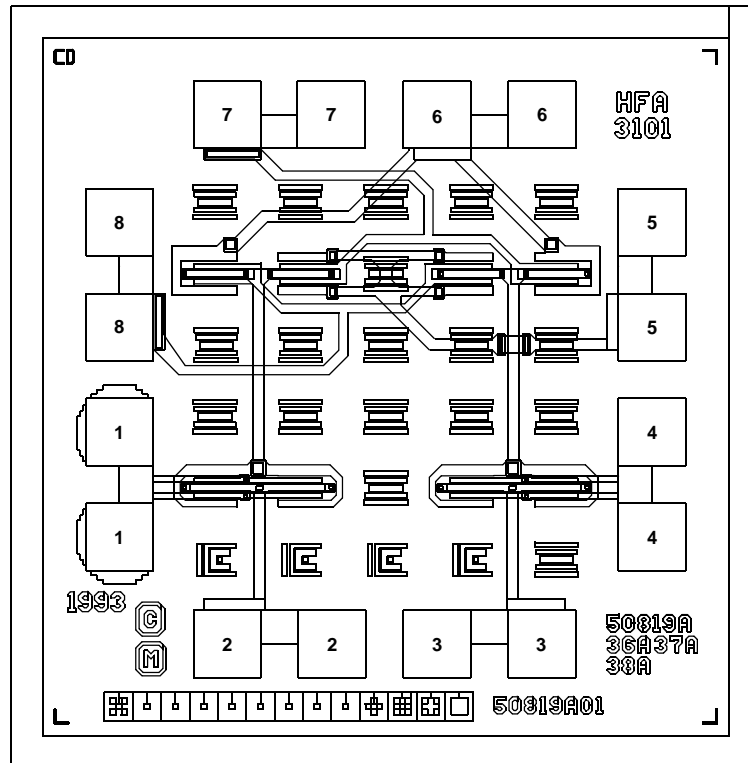

All Intersil semiconductor products are manufactured, assembled and tested under **ISO9000** quality systems certification.

Intersil semiconductor products are sold by description only. Intersil Corporation reserves the right to make changes in circuit design and/or specifications at any time without notice. Accordingly, the reader is cautioned to verify that data sheets are current before placing orders. Information furnished by Intersil is believed to be accurate and reliable. However, no responsibility is assumed by Intersil or its subsidiaries for its use; nor for any infringements of patents or other rights of third parties which may result from its use. No license is granted by implication or otherwise under any patent or patent rights of Intersil or its subsidiaries.

For information regarding Intersil Corporation and its products, see web site www.intersil.com