

DUAL TONE and POLARITY SWITCH LNB MULTIPLEX CONTROLLER

ISSUE 1- NOVEMBER 1998

ZLNB2001	ZLNB2002
ZLNB2003	ZLNB2004

DEVICE DESCRIPTION

The ZLNB200X dual polarisation and tone switch controller is one of a wide range of satellite receiver LNB support circuits available from Zetex. It features two completely independent channels, each providing logic outputs to control LNB polarisation selection, local oscillator selection and downfeed disable. It is intended for use in Twin Universal LNBs, replacing many discrete components to save both manufacturing cost and PCB size whilst improving reliability.

The two polarisation control inputs of the ZLNB200X have a nominal threshold of 14.75V. The threshold is temperature compensated to minimise drift. Each features a low and stable input current that enables transient protection to be achieved with the addition of only a single resistor per channel.

Twin Universal LNBs can be called to operate with one of their controlling receivers powered down/disconnected, with attendant cable mismatch problems. To ease design for this situation, each polarisation input of the ZLNB200X has a second threshold set at 9.5V. An input voltage below this threshold indicates

"receiver not present", switching the channels Enable pin low. This logic output can be used to disable the associated downfeed driver, eliminating any problems due to cable mismatch.

Universal LNB local oscillator selection is achieved by detection of a low level AC voltage superimposed on the polarisation control voltage. To facilitate this function, the ZLNB200X includes a separate tone detector for each channel. Full control of detector bandwidth and sensitivity is provided using two external resistors and capacitors. In the ZLNB2003/4, additional control of tone switch delays is provided to assist with the rejection of low frequency control signals intended for other systems.

Polarisation switch and tone detector outputs can source and sink 10mA making them suitable to drive TTL and CMOS logic, pin diodes and for IF-amp supply switching.

The ZLNB200X operates from a single supply which can be anything from 5-10V. Its quiescent current is typically only 6mA and this does not change significantly with load or logic state. It is available in the space saving QSOP16 surface mount package.

FEATURES

- Dual polarisation switch
- Temperature compensated polarisation switch threshold
- Transient resistant inputs
- Includes Receiver-Off detector
- Dual tone switch
- User adjustable filter centre frequency and bandwidth
- User adjustable tone switching delays (ZLNB2003/4 only)
- Tone and pol. outputs TTL, CMOS, Pin diode and IF amp capable

- Receiver-Off detector TTL and CMOS compatible
- Wide supply operating range
- Low quiescent current
- Few external components
- Eliminates many discrete components

APPLICATIONS

- Twin Universal LNB
- Twin Universal IF switch boxes
- LNB switch boxes

ZLNB2001 ZLNB2002
ZLNB2003 ZLNB2004

ABSOLUTE MAXIMUM RATINGS

Supply Voltage	-0.6V to 12V
Supply Current	100mA
V _{POL1} and V _{POL2}	
Input Voltage	25V Continuous
Operating Temperature	-40 to 70°C
Storage Temperature	-40 to 85°

Power Dissipation (T_{amb}= 25°C)

QSOP16	500mW
--------	-------

ELECTRICAL CHARACTERISTICS TEST CONDITIONS (Unless otherwise stated):
T_{amb}= 25°C, V_{CC}=5V, I_D=10mA (R_{CAL1}=33kΩ)

SYMBOL	PARAMETER	CONDITIONS	LIMITS			UNITS
			Min	Typ	Max	
V _{CC}	Supply Voltage		5		10	V
I _{CC}	Supply Current	I _{HV_{out1,2}} =I _{T_{out1,2}} =0 I _{T_{out1,2}} =0, I _{HV_{out1,2}} =10mA, V _{POL} =15.5V		5.5	12	mA
I _{POL}	V _{POL1} and V _{POL2} Inputs Current	V _{POL1} = V _{POL2} = 25V (Note 2)	10	25	40	μA
V _{TPOL}	Threshold Voltage	T _{amb} =-40°C to 70°C (Note 2)	14.0	14.75	15.5	V
T _{SPOL}	Switching Speed				100	μs
	I _{HV_{out1}} and I _{HV_{out2}} Outputs					
V _{HV_{HIGH}}	Voltage High	I _{HV_{out1,2}} =-20μA, V _{POL1,2} = 15.5V	V _{CC} -0.2	V _{CC} -0.1	V _{CC}	V
V _{HV_{HIGH}}	Voltage High	I _{HV_{out1,2}} =-10μA, V _{POL1,2} = 15.5V	V _{CC} -1.0	V _{CC} -0.9	V _{CC}	V
V _{HV_{LOW}}	Voltage Low	I _{HV_{out1,2}} =-10μA, V _{POL1,2} = 14V	0	0.29	0.5	V
	Enable 1,2 Outputs					
V _{EN_{HIGH}}	Voltage High	I _{Enable1,2} =-100μA, V _{POL1,2} = 10V	V _{CC} -1.0	V _{CC} -0.75	V _{CC}	V
V _{EN_{HIGH}}	Voltage High	I _{Enable1,2} =20μA, V _{POL1,2} = 8.0V	0	0.14	V _{CC}	V
V _{EN_{LOW}}	Voltage Low	I _{Enable1,2} =500μA, V _{POL1,2} =8.0V	0	0.25	0.5	V
	Filter Amplifier					
I _B	Input Bias Current	R _{F1} =150k	0.02	0.07	0.25	μA
V _{out}	V _{out} (Note 1)	R _{F1} =150k	1.75	1.95	2.15	V
I _{out}	I _{out} (Note 1)	V _{out} =1.96V, V _{fin} =2.1V	400	520	650	μA
G _V	Voltage Gain	F=22kHz, V _{in} =1mV	0	46		dB
	Rectifier (ZLNB2003 and ZLNB2004 ONLY)					
V _{REC}	V _{out} (Note 1)	R _{F1} =150k, I _L =10μA	1.8	2.0	2.2	V
	I _{Leakage}	R _{F1} =150k, V _{out} =3V (Note 1)		20	200	nA

ZLNB2001 ZLNB2002 ZLNB2003 ZLNB2004
--

ELECTRICAL CHARACTERISTICS TEST CONDITIONS (Unless otherwise stated):
 $T_{amb}=25^{\circ}C, V_{CC}=5V, I_D=10mA (R_{CAL1}=33k\Omega)$

SYMBOL	PARAMETER		LIMITS			UNITS
			Min	Typ	Max	
V _{TH}	Comparator (ZLNB2003 and ZLNB2004 ONLY)					
	Threshold (Note 1)	F=0	2.95	3.2	3.45	V
V _{VHIGH}	Tout 1/2 Outputs Voltage High	ITout1,2=-20μA, Test Circuit 1, Tone enabled	V _{CC} -0.2	V _{CC} -0.1	V _{CC}	V
V _{VHIGH}	Voltage High	ITout1,2=-10mA, Test Circuit 1, Tone enabled	V _{CC} -1.0	V _{CC} -0.9	V _{CC}	V
V _{VLOW}	Voltage Low	ITout1,2=10mA, Test Circuit 1, Tone disabled	0	0.29	0.5	V

Note:-

1) The parameters Filter Amplifier Vout, Iout, Rectifier Vout and Comparator Threshold Voltage are all directly (linearly) related to Vcc.

2) Applied via 10k resistors

TEST CIRCUIT 1

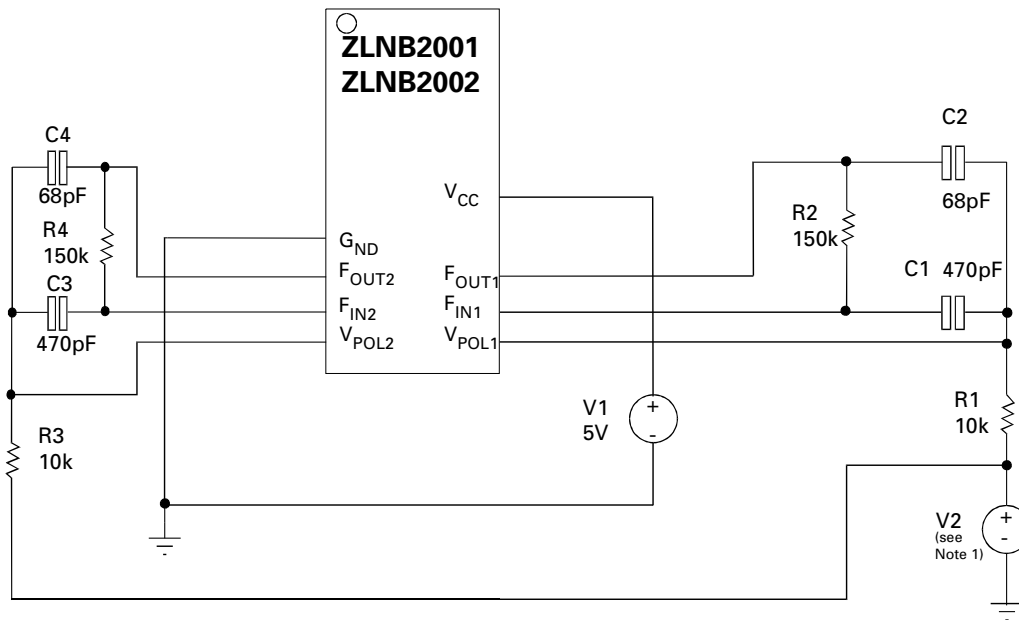

TEST CIRCUIT 2

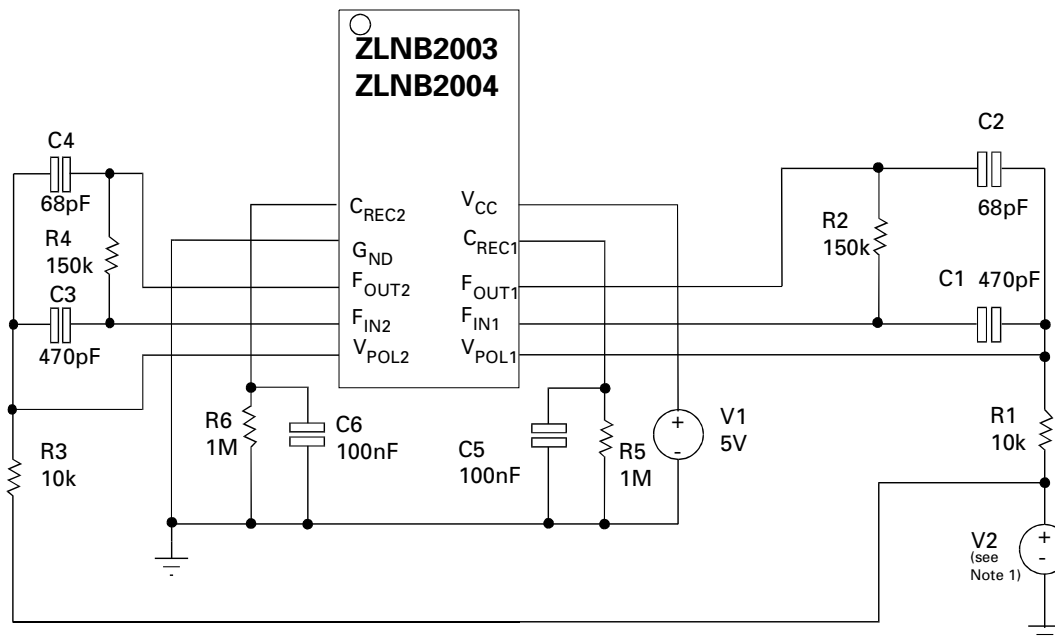

TYPICAL CHARACTERISTICS

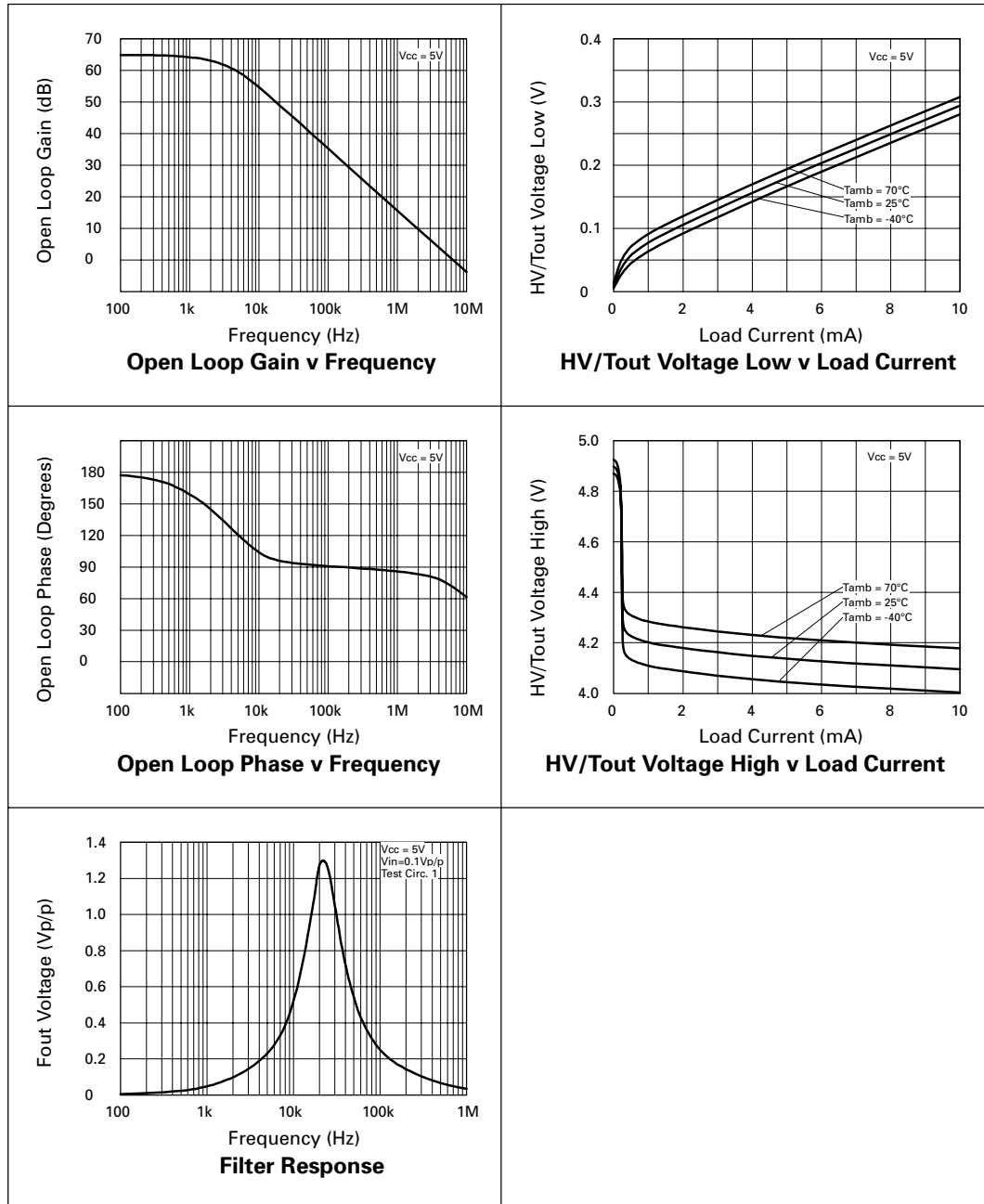

**ZLNB2001 ZLNB2002
ZLNB2003 ZLNB2004**

The following block diagram shows a typical block diagram twin universal LNB design. The ZLNB200X devices provides the two polarity and two tone switches required to decode the two independent receiver feeds. The devices are also able detect the absence of a receiver connected to either port of the LNB providing an Enable signal allowing the

disabling of the port. This allows the avoidance of unwanted signal reflections from an unterminated down feed cable.

Additionally the front end bias requirements of the LNB are provided by the ZNBG4000 or ZNBG6000 offering a very efficient and cost effective solution.

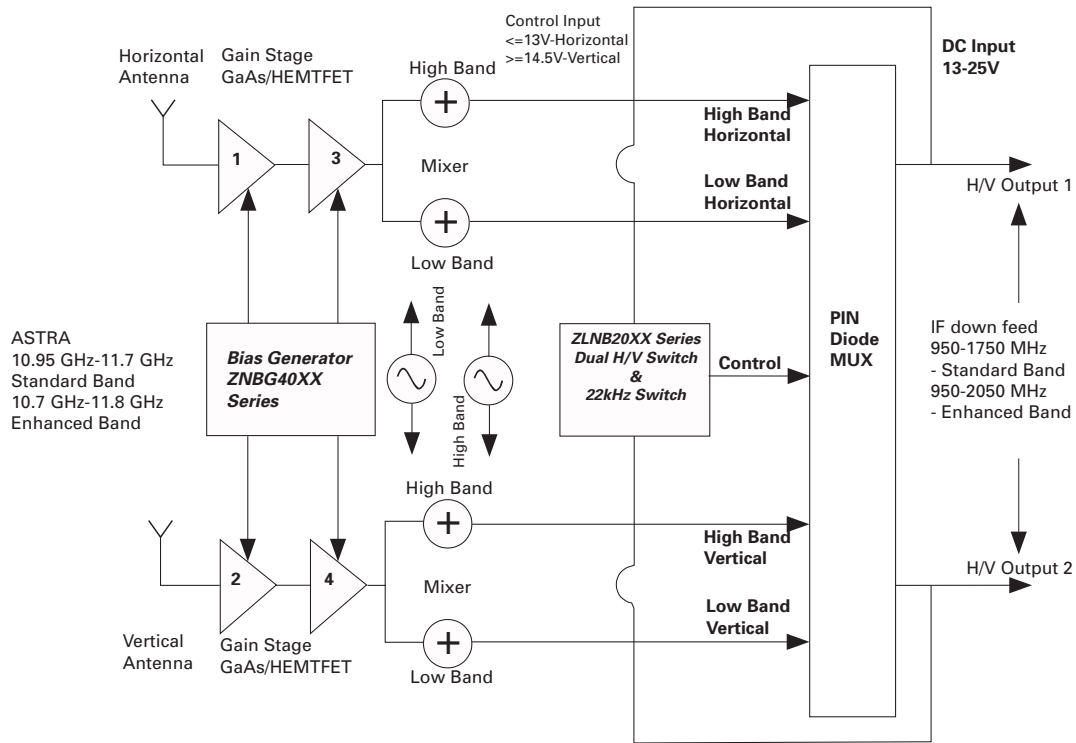

ASTRA
10.95 GHz-11.7 GHz
Standard Band
10.7 GHz-11.8 GHz
Enhanced Band

**ZLNB2001 ZLNB2002
ZLNB2003 ZLNB2004**

APPLICATION CIRCUIT EXAMPLES

The following circuit shows the additional components that will be used for polarisation mode and 22kHz tone detection in a typical ZLNB2001/2 application.

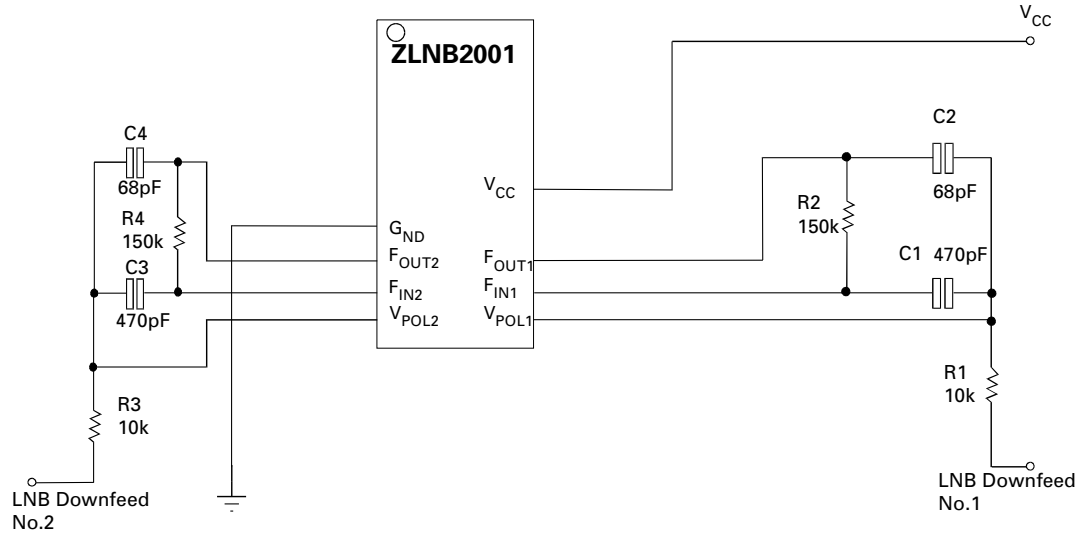

The following circuit shows the additional components that will be used for polarisation mode and 22kHz tone detection in a typical ZLNB2003/4 application.

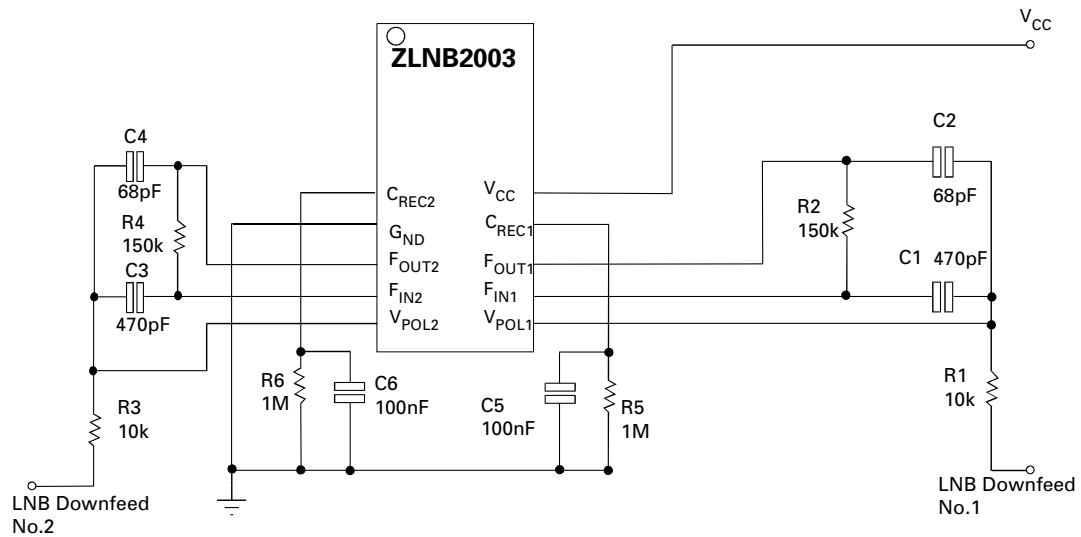

FURTHER INFORMATION

- 1) Inputs V_{POL1} and V_{POL2} are designed to be wired to the power inputs of an LNB via high value (10k) resistors. Input V_{POL1} controls outputs HVout1 and Enable1. Input V_{POL2} controls outputs HVout2 and Enable2. With either input voltage set at or below 14V, the corresponding HVout pin will be in active. With either input voltage at or above 15.5V, the corresponding HVout pin will be active. Should the voltage applied to either V_{POL} input fall below 8V, the corresponding Enable pin will be low, otherwise these outputs will be high. Any input or output not required may be left open-circuit.
- 2) The ZLNB2001/2 includes the circuitry necessary to detect the presence of 22kHz tones modulated on either of two supply inputs to the LNB. The main elements of the detectors in each channel are an op-amp enabling the construction of a Sallen Key filter, a rectifier/smoothen and a comparator. Full user control is given over the centre frequency and bandwidth of the filter using two external resistors and capacitors (one of these resistors shares the function of overvoltage protection of the corresponding V_{POL} pin, i.e. the 10k referenced in note 1). The comparator circuit utilises no external components. The presence of a 22kHz tone applied to pin Fin1 or Fin2 switches the corresponding output Tout1 or Tout2 high.
- 3) The ZLNB2003 / 4 includes the circuitry necessary to detect the presence of 22kHz tones modulated on either of two supply inputs to the LNB. The main elements of the detectors in each channel are an op-amp enabling the construction of a Sallen Key filter, a rectifier/smoothen and a comparator. Full user control is given over the centre frequency and bandwidth of the filter using two external resistors and capacitors (one of these resistors shares the function of overvoltage protection of the corresponding V_{POL} pin, i.e. the 10k referenced in note 1). The comparator circuit utilises no external components. The presence of a 22kHz tone applied to pin Fin1 or Fin2 switches the corresponding output Tout1 or Tout2

high. Pins Crec1 and Crec2 make accessible the outputs of the tone switch rectifiers and provides a means of controlling tone switch delays. Significant switching delays may be necessary to avoid incorrect operation in the presence of unwanted interference (e.g. switching tones intended for other signalling systems). For correct operation of the IC, a capacitor and a parallel connected resistor should be connected between each Crec pin and ground. The Tout low to high delays are set solely by the added capacitors at approximately 22ms/uF. The high to low delays are set by the time constant of each resistor capacitor combination at approximately 0.2CR seconds. A capacitor of 100nF and resistor of 1MW will give a low to high delay of around 2.2ms and a high to low delay of 20ms, providing immunity to the 60Hz square wave signal occasionally used for switching between multiple LNB units.

tone DETECTION FUNCTION

	Fin1	Fin2	Tout 1	Tout 2	
ZLNB2001/3	22kHz	22kHz	High	High	
	-	-	Low	Low	
ZLNB2002/4	22kHz	22kHz	High	High	
	-	-	Low	Low	
	V _{POL1}	V _{POL2}	HV _{OUT1}	HV _{OUT2}	Enable 1 /2
ZLNB2001/3	<=14V	<=14V	Low	Low	High
	>=15.5V	>=15.5V	High	High	High
ZLNB2002/4	<=14V	<=14V	High	High	High
	>=15.5V	>=15.5V	Low	Low	High
ZLNB2001,2,3,4	<=8V	<=8V	-	-	Low

**ZLNB2001 ZLNB2002
ZLNB2003 ZLNB2004**

CONNECTION DIAGRAMS

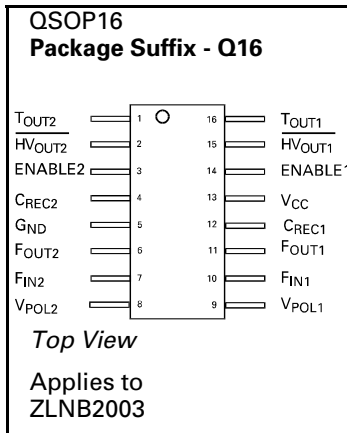
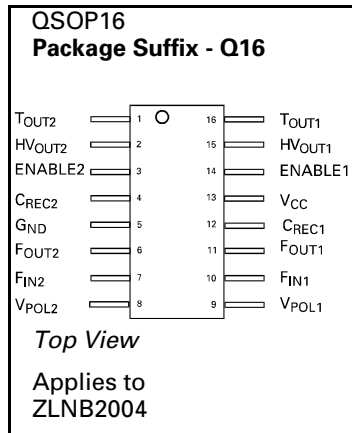
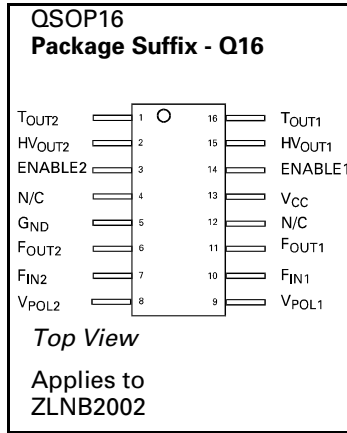
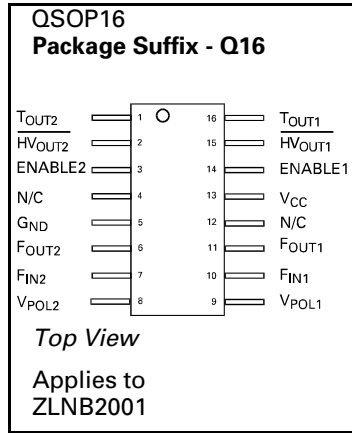

ORDERING INFORMATION

Part Number	Package	Part Mark
ZLNB2001Q16	QSOP16	ZLNB2001
ZLNB2002Q16	QSOP16	ZLNB2002
ZLNB2003Q16	QSOP16	ZLNB2003
ZLNB2004Q16	QSOP16	ZLNB2004

ZLNB2001 ZLNB2002
ZLNB2003 ZLNB2004

PACKAGE DIMENSIONS

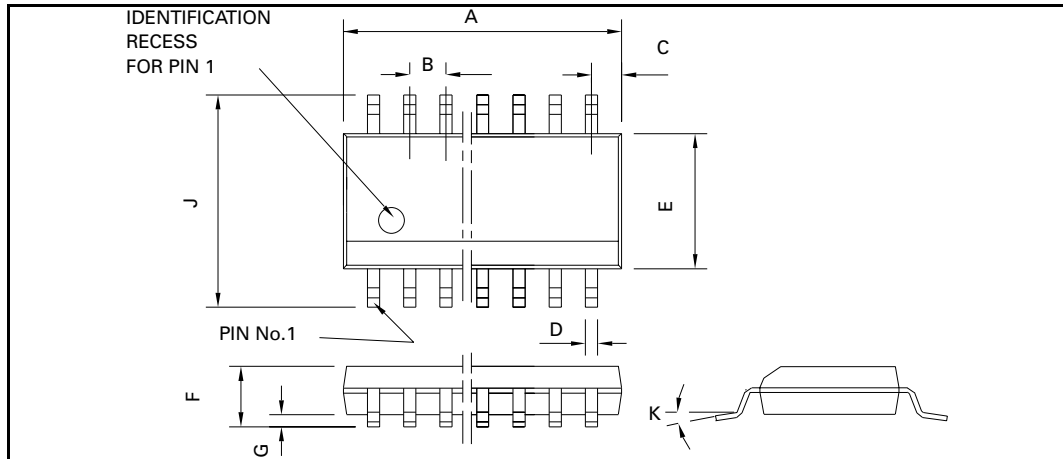

OSOP16

DIM	Millimetres		Inches	
	MIN	MAX	MIN	MAX
A	4.80	4.98	0.189	0.196
B	0.635		0.025 NOM	
C	0.177	0.267	0.007	0.011
D	0.20	0.30	0.008	0.012
E	3.81	3.99	0.15	0.157
F	1.35	1.75	0.053	0.069
G	0.10	0.25	0.004	0.01
J	5.79	6.20	0.228	0.244
K	0°	8°	0°	8°

ZLNB2001 ZLNB2002
ZLNB2003 ZLNB2004

MSOP8

DIM	Millimetres		Inches	
	MIN	MAX	MIN	MAX
A	0.91	1.11	0.036	0.044
A1	0.10	0.20	0.004	0.008
B	0.25	0.36	0.010	0.014
C	0.13	0.18	0.005	0.007
D	2.95	3.05	0.116	0.120
e	0.65	NOM	0.0256	NOM
e1	0.33	NOM	0.0128	NOM
E	2.95	3.05	0.116	0.120
H	4.78	5.03	0.188	0.198
L	0.41	0.66	0.016	0.026
θ°	0°	6°	0°	6°

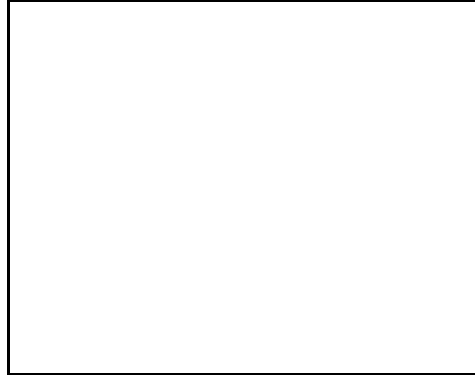

S08

DIM	Millimetres		Inches	
	Min	Max	Min	Max
A	4.80	4.98	0.189	0.196
B	1.27 BSC		0.05 BSC	
C	0.53 REF		0.02 REF	
D	0.36	0.46	0.014	0.018
E	3.81	3.99	0.15	0.157
F	1.35	1.75	0.05	0.07
G	0.10	0.25	0.004	0.010
J	5.80	6.20	0.23	0.24
K	0°	8°	0°	8°
L	0.41	1.27	0.016	0.050

