

LOC	DIST	REVISIONS				
P	LTR	DESCRIPTION	DATE	DWN	APVD	
E	B	BA	NEW RELEASE	08SEP2010	PT	St.P

FOR FURTHER INFORMATION SEE DATA SHEET FOR  
RN73 SERIES-HIGH PRECISION RESISTORS (SMD)

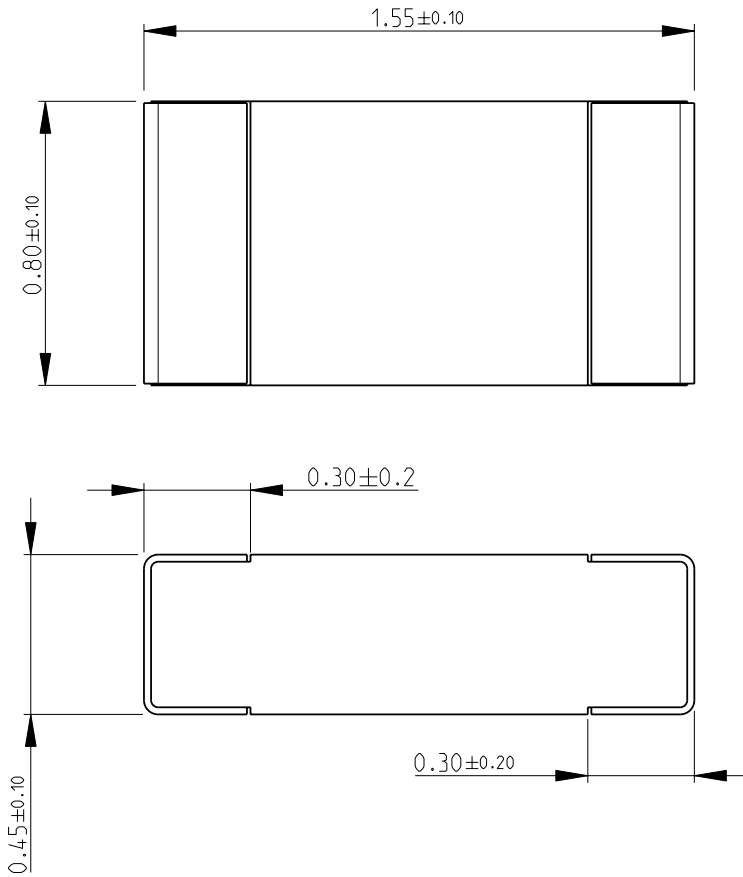

RECOMMENDED LAND PATTERN

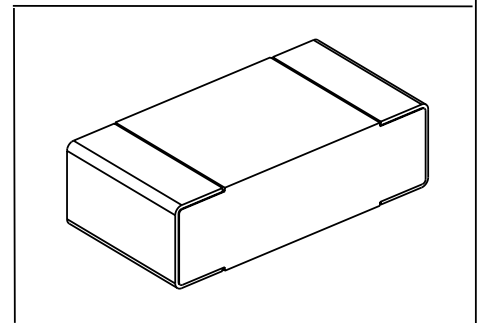
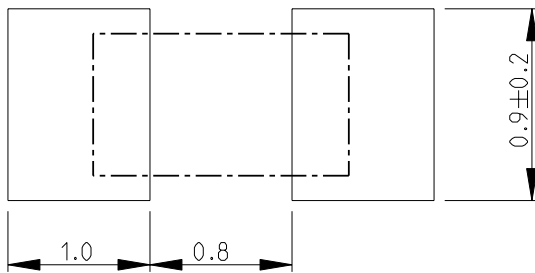

2010

RELEASED FOR PUBLICATION

BY TYCO ELECTRONICS CORPORATION. ALL RIGHTS RESERVED.

© COPYRIGHT 2010

THIS DRAWING IS UNPUBLISHED.

DIMENSIONS: mm  TOLERANCES UNLESS OTHERWISE SPECIFIED:  0 PLC ±0.2 1 PLC ±0.1 2 PLC ±- 3 PLC ±- 4 PLC ±- ANGLES ±5°	DWN PARUSURAM.T 08SEP2010	MATERIAL -	FINISH -		
	CHK ALLAN.P 08SEP2010	Tyco Electronics Corporation Dorcan, Swindon, SN3 5HH			
APVD STEPHEN.P 08SEP2010	NAME HIGH PRECISION RESISTORS (SMD) SERIES RN73 1J				
PRODUCT SPEC -	APPLICATION SPEC -	SIZE A 4	CAGE CODE 00779	DRAWING NO C= 1879134	RESTRICTED TO -
WEIGHT -	CUSTOMER DRAWING		SCALE 20:1	SHEET 1 OF 1	REV BA