

CLASSIFICATION Einstufung	PRODUCT SPECIFICATION Produktspezifikation	No. DS-1315-2400-102	REV. 0.98
SUBJECT Thema	CLASS 2 BLUETOOTH MODULE Bluetooth Modul der Klasse 2	PAGE Seite	1 of 32
CUSTOMER'S CODE PAN1315	PANASONIC'S CODE ENW89818C2JF	DATE Datum	21.04.2009

## Specification for Production

Applicant / Manufacturer      Panasonic Electronic Devices Europe GmbH  
Hardware                              Zeppelinstrasse 19  
    21337 Lüneburg  
    Germany

Applicant / Manufacturer      tbd  
Software

Software Version                      tbd

Contents                                  Approval for Mass Production

Customer

By signing this document, you acknowledge that you are the legal representative for your company and that you understand and accept the validity of the contents herein. Customer acknowledges that samples may deviate from the Data Sheet and may bear defects due to their status of development and the lack of qualification mentioned above.

Panasonic rejects any liability or product warranty for Engineering Samples. In particular, Panasonic disclaims liability for damages caused by

- the use of the Engineering Sample other than for Evaluation Purposes, particularly the installation or integration in an other product to be sold by Customer,
- deviation or lapse in function of Engineering Sample,
- improper use of Engineering Samples.

Panasonic disclaims any liability for consequential and incidental damages.

CHECKED / APPROVED:

DATE:	NAME:	SIGNATURE:

HIGH FREQUENCY PRODUCTS DIVISION Module Business PANASONIC ELECTRONIC DEVICES EUROPE GmbH	APPROVED genehmigt	CHECKED geprüft	DESIGNED erstellt
--	-----------------------	--------------------	----------------------

CLASSIFICATION Einstufung	PRODUCT SPECIFICATION Produktspezifikation	No. DS-1315-2400-102	REV. 0.98
SUBJECT Thema	CLASS 2 BLUETOOTH MODULE Bluetooth Modul der Klasse 2	PAGE Seite	2 of 32
CUSTOMER'S CODE PAN1315	PANASONIC'S CODE ENW89818C2JF	DATE Datum	21.04.2009

## TABLE OF CONTENTS

1.	Scope of this Document .....	4
2.	Key Features .....	4
3.	Applications for the Module .....	5
4.	Description for the Module .....	5
5.	Detailed Description .....	6
5.1.	PAN1315 Terminal Layout .....	6
5.2.	Pin Description .....	7
5.3.	Device Power Supply .....	8
5.4.	Clock Inputs .....	9
6.	Bluetooth Features .....	10
7.	Block Diagram .....	11
8.	Test Conditions .....	11
9.	General Device Requirements and Operation .....	11
9.1.	Absolute Maximum Ratings .....	12
9.2.	Recommended Operating Conditions .....	12
9.3.	Current Consumption .....	13
9.4.	General Electrical Characteristics .....	13
9.5.	nSHUTD Requirements .....	14
9.6.	External Digital Slow Clock Requirements (-20°C to +70°C) .....	14
10.	Bluetooth RF Performance (BT) .....	15
10.1.	Bluetooth Receiver Characteristics – In-Band Signals .....	15
10.2.	Bluetooth Receiver Characteristics – General Blocking .....	16
10.3.	Bluetooth Receiver Characteristics – GFSK/EDR2/EDR3 .....	16
10.4.	Bluetooth Transmitter, GFSK, Full output .....	16
10.5.	Bluetooth Transmitter, EDR, Full output .....	17
10.6.	Bluetooth Modulation, GFSK, Full output .....	17
10.7.	Bluetooth Modulation, EDR, Full output .....	18
10.8.	Bluetooth Transmitter, Out-of-Band Emissions .....	18
11.	Soldering Temperature-Time Profile (for reflow soldering) .....	19
11.1.	For lead solder .....	19
11.2.	For leadfree solder .....	19
12.	Module Dimension .....	20
13.	FootPrint of the Module .....	20
14.	Labelling Drawing .....	21
14.1.	Engineering Samples .....	21
14.2.	Mass Production .....	21
15.	Mechanical Requirements .....	21
16.	Recommended Foot Pattern .....	22
17.	Development of Applications .....	23

CLASSIFICATION Einstufung	PRODUCT SPECIFICATION Produktspezifikation	No. DS-1315-2400-102	REV. 0.98
SUBJECT Thema	CLASS 2 BLUETOOTH MODULE Bluetooth Modul der Klasse 2	PAGE Seite	3 of 32
CUSTOMER'S CODE PAN1315	PANASONIC'S CODE ENW89818C2JF	DATE Datum	21.04.2009

17.1. Tools to be needed .....	23
18. Reliability Tests .....	24
19. Cautions .....	24
19.1. Design Notes .....	24
19.2. Installation Notes .....	24
19.3. Usage Conditions Notes .....	25
19.4. Storage Notes .....	25
19.5. Safety Cautions .....	26
19.6. Other cautions .....	26
20. Packaging .....	27
20.1. Tape Dimension.....	27
20.2. Packing in Tape .....	27
20.3. Component direction.....	28
20.4. Reel Dimension .....	28
20.5. Label for Package.....	29
20.6. Total Package.....	29
21. Ordering Information .....	30
22. RoHS Declaration .....	30
23. Data Sheet Status .....	30
24. History for this Document.....	31
25. Related Documents.....	31
26. General Information .....	32
27. Regulatory Information.....	32
27.1. FCC Warning .....	32
28. Life Support Policy .....	32

CLASSIFICATION Einstufung	PRODUCT SPECIFICATION Produktspezifikation	No. DS-1315-2400-102	REV. 0.98
SUBJECT Thema	CLASS 2 BLUETOOTH MODULE Bluetooth Modul der Klasse 2	PAGE Seite	4 of 32
CUSTOMER'S CODE PAN1315	PANASONIC'S CODE ENW89818C2JF	DATE Datum	21.04.2009

## 1. SCOPE OF THIS DOCUMENT

This product specification applies to Panasonic's HCI, class 2, Bluetooth®<sup>1</sup> module, series number: PAN1315. Different versions of the PAN1315 are available (refer to chapter 21 Ordering Information).

The Bluetooth chip used is the CC2560 from Texas Instruments ([www.ti.com](http://www.ti.com)).

## 2. KEY FEATURES

- Bluetooth specification v2.1 + EDR (**Enhanced Data Rate**)
- Surface mount type 6.5 x 9.0 x 1.8 mm<sup>3</sup>
- 10dBm Tx power (typical) with transmit power control
- High sensitivity (-91 dBm typ.)
- Optional EEPROM for increased operating temperature range and decreased start up time
- Texas Instrument's CC2560 BlueLink 7.0 inside
- Complete Co-location and Co-existence with IEEE 802.11 (AWMA, AFH and SFH)
- Fast Connection Setup
- Extended SCO Link
- Supports convenient direct connection to battery (2.2-4.8 V), or connect to DC/DC (1.7-1.98 V) for improved power efficiency
- Internal crystal oscillator (26MHz)
- Built-in shielding to be compliant to FCC
- Full Bluetooth data rate up to 2178kbps asymmetric
- Support for all Bluetooth power saving modes (Sniff, Hold)
- Support for very low-power modes (deep sleep and power down)
- Optional support for ultra-low-power mode. Standby with Battery-Backup
- PCM Interface Master / Slave supporting 13 or 16 bit linear, 8 bit  $\mu$ -law or A-law Codecs and CVSD transcoders on up to 3 SCO channels
- ROM based firmware with patch trap mechanism and reserved RAM, enables easy bug fixes and new firmware features to be added through external script.
- Full 8- to 128-bit encryption
- UART, I<sup>2</sup>C, PCM and SPI Interface
- 2 GPIO's for defined usage
- IO operating voltage = 1.8 V nominal
- 3 Channel ADC and 1 Channel DAC
- Bluetooth profiles such as SPP, HDP are available. Refer to Panasonic's RF module website for a listing of the most current releases.
- Manufactured in conformance with RoHS

<sup>1</sup> Bluetooth is a registered trademark of the Bluetooth Special Interest Group.

CLASSIFICATION Einstufung	PRODUCT SPECIFICATION Produktspezifikation	No. DS-1315-2400-102	REV. 0.98
SUBJECT Thema	CLASS 2 BLUETOOTH MODULE Bluetooth Modul der Klasse 2	PAGE Seite	5 of 32
CUSTOMER'S CODE PAN1315	PANASONIC'S CODE ENW89818C2JF	DATE Datum	21.04.2009

### 3. APPLICATIONS FOR THE MODULE

#### All Embedded Wireless Applications

- Access Points
- Industrial Control
- Medical
- Scanners
- Wireless Sensors
- Low Power
- Cable Replacement
- Personal Digital Assistants (PDAs)
- Access Points
- Computers and Peripherals
- Printer Adapters
- Printers

### 4. DESCRIPTION FOR THE MODULE

The PAN1315 is a short-range class 2 HCI module for implementing Bluetooth functionality into various electronic devices. A block diagram can be found in chapter 7.

Communication between the module and the host controller is carried out normally via UART, but also SPI is supported with this hardware.

The main software solutions are available from Mindtree Ltd. Please refer to chapter 3. These software packages are based on TI's MSP430 platform .

Please contact your local sales office for further details on additional options and services, by visiting [www.panasonic.com/rfmodules](http://www.panasonic.com/rfmodules) or write an e-mail to [wireless@eu.panasonic.com](mailto:wireless@eu.panasonic.com).

CLASSIFICATION Einstufung	PRODUCT SPECIFICATION Produktspezifikation	No. DS-1315-2400-102	REV. 0.98
SUBJECT Thema	CLASS 2 BLUETOOTH MODULE Bluetooth Modul der Klasse 2	PAGE Seite	6 of 32
CUSTOMER'S CODE PAN1315	PANASONIC'S CODE ENW89818C2JF	DATE Datum	21.04.2009

## 5. DETAILED DESCRIPTION

### 5.1. PAN1315 TERMINAL LAYOUT

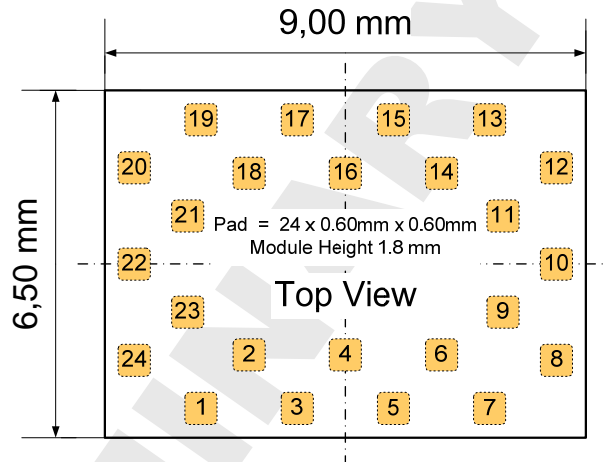

No	Pin Name	ESD <sup>1</sup> (V)	Pull at Reset	Def. Dir. <sup>2</sup>	I/O Type <sup>3</sup>	Description of Options (Common)
1	GND					Connect to Ground
2	TX_DBG	1000	PU	O	2 mA	Logger output
3	HCI_CTS	750	PU	I	8 mA	HCI UART clear-to-send.
4	HCI_RTS	750	PU	O	8 mA	HCI UART request-to-send.
5	HCI_RX	750	PU	I	8 mA	HCI UART data receive
6	HCI_TX	750	PU	O	8 mA	HCI UART data transmit
7	AUD_FSYNC	500	PD	IO	4 mA	PCM frame synch. (NC if not used) Fail safe <sup>4</sup>
8	SLOW_CLK_IN	1000		I		32.768-kHz clock in Fail safe
9	IO2	1000	PD	IO	2 mA	BT_FUNC2
10	MLDO_OUT	1000		O		Main LDO output (1.8 V nom.)
11	CL1.5_LDO_IN	1000		I		PA LDO input
12	GND					Connect to Ground
13	RF	1000		IO		Bluetooth RF IO
14	GND					Connect to Ground
15	MLDO_IN	1000		I		Main LDO input
16	nSHUTD	1000	PD	I		Shutdown input (active low).
17	AUD_OUT	500	PD	O	4 mA	PCM data output. (NC if not used) Fail safe
18	AUD_IN	500	PD	I	4 mA	PCM data input. (NC if not used) Fail safe
19	AUD_CLK	500	PD	IO	HY, 4 mA	PCM clock. (NC if not used) Fail safe
20	GND					Connect to Ground
21	I2C_SDA	1000	PU/PD	IO	HY, 4 mA	EEPROM I <sup>2</sup> C SDA (NC if not used)
22	VDD_IO	1000		PI		I/O power supply 1.8 V Nom
23	I2C_SCL	1000	PU/PD	I	HY, 4 mA	EEPROM I <sup>2</sup> C SCL (NC if not used)
24	IO1	750	PD	IO	8 mA	BT_FUNC1

<sup>1</sup> ESD: Human Body Model (HBM). JEDEC 22-A114

<sup>2</sup> I = input; O = output; IO = bidirectional; P = power; PU = pulled up; PD = pulled down

<sup>3</sup> I/O Type: Digital I/O cells. HY = input hysteresis, current = typ. output current

<sup>4</sup> No signals are allowed on the IO pins if no VDD\_IO (Pin 22) power supplied, except pin 7, 8, 17-20.

CLASSIFICATION Einstufung	PRODUCT SPECIFICATION Produktspezifikation	No. DS-1315-2400-102	REV. 0.98
SUBJECT Thema	CLASS 2 BLUETOOTH MODULE Bluetooth Modul der Klasse 2	PAGE Seite	7 of 32
CUSTOMER'S CODE PAN1315	PANASONIC'S CODE ENW89818C2JF	DATE Datum	21.04.2009

## 5.2. PIN DESCRIPTION

Pin Name	No	ESD <sup>1</sup> (V)	Pull at Reset	Def. Dir. <sup>2</sup>	I/O Type <sup>3</sup>	Description of Options
Bluetooth IO SIGNALS						
HCI_RX	5	750	PU	I	8 mA	HCI UART data receive OPTION: BPSPI_DI – SPI data in
HCI_TX	6	750	PU	O	8 mA	HCI UART data transmit OPTION: BPSPI_DO – SPI data out
HCI_RTS	4	750	PU	O	8 mA	HCI UART request-to-send. Option: BPSPI_IRQ
HCI_CTS	3	750	PU	I	8 mA	HCI UART clear-to-send. OPTION: BPSPI_CS – SPI chip select
AUD_FYSNC	7	500	PD	IO	4 mA	PCM frame synch (NC if not used) Fail safe
AUD_CLK	19	500	PD	IO	HY, 4 mS	PCM clock (NC if not used) Fail safe
AUD_IN	18	500	PD	I	4 mA	PCM data input (NC if not used) Fail safe
AUD_OUT	17	500	PD	O	4 mA	PCM data output (NC if not used) Fail safe
IO1	24	750	PD	IO	8 mA	BT_FUNCT1
						OPTION: HOST_WAKEUP – TI internal
						OPTION: BT_PRIORITY – WLAN coex signal
						OPTION: DEBUG1 – TI internal
IO2	9	1000	PD	IO	8 mA	OPTION: BTSPI_CLK – SPI clock
						OPTION: EXT_PA_CMD2 – Class 1 ext. amp control
						BT_FUNCT2
						OPTION: DEBUG2 – TI internal
TX_DBG	2	1000	PU	O	2 mA	OPTION: BT_WAKEUP – TI internal
						OPTION: EXT_PA_EN – Class 1 ext. amp. control
						OPTION: BT_RF_ACTIVE – WLAN coex signal
						Logger output
TX_DBG	2	1000	PU	O	2 mA	OPTION: BT_FUNCT3
						OPTION: DEBUG3 – TI internal
						OPTION: BT_PRIORITY – WLAN coex signal
						OPTION: nEXT_PA_EN – Class 1 ext. amp. control
TX_DBG	2	1000	PU	O	2 mA	OPTION: nTX_DBG – logger out (low = 1)
CLOCK SIGNALS						
SLOW_CLK_IN	8	1000		I		32.768-kHz clock in Fail safe
Bluetooth ANALOG SIGNALS						
RF	13	1000		IO		Bluetooth RF IO
nSHUTD	16	1000	PD	I		Shutdown input (active low).
Bluetooth POWER AND GND SIGNALS						
VDD_IO	22	1000		PI		I/O power supply 1.8 V Nom
MLDO_IN	15	1000		I		Main LDO input Connect directly to battery or to a pre-regulated 1.8-V supply
MLDO_OUT	10	1000		O		Main LDO output (1.8 V nom.)
CL1.5_LDO_IN	11	1000		I		PA LDO input Connect directly to battery or to a pre-regulated 1.8-V supply
GND	1			P		Connect to Ground
GND	12			P		Connect to Ground
GND	14			P		Connect to Ground
GND	20			P		Connect to Ground

<sup>1</sup> ESD: Human Body Model (HBM). JEDEC 22-A114

<sup>2</sup> I = input; O = output; IO = bidirectional; P = power; PU = pulled up; PD = pulled down

<sup>3</sup> I/O Type: Digital I/O cells. HY = input hysteresis, current = typ output current

CLASSIFICATION Einstufung	PRODUCT SPECIFICATION Produktspezifikation	No. DS-1315-2400-102	REV. 0.98
SUBJECT Thema	CLASS 2 BLUETOOTH MODULE Bluetooth Modul der Klasse 2	PAGE Seite	8 of 32
CUSTOMER'S CODE PAN1315	PANASONIC'S CODE ENW89818C2JF	DATE Datum	21.04.2009

Pin Name	No	ESD <sup>1</sup> (V)	Pull at Reset	Def. Dir. <sup>2</sup>	I/O Type <sup>3</sup>	Description of Options
EEPROM IO SIGNALS (EEPROM is an option in our PAN1315)						
I2C_SCL	23	1000	PU/PD	I	HY, 4mA	EEPROM I <sup>2</sup> C SCL (NC if not used)
						OPTION: BT_RF_ACTIVE – WLAN coex signal
						OPTION: BT_PRIORITY – WLAN coex signal
						OPTION: BT_FREQ – WLAN coex signal
						OPTION: EXT_PA_EN – Class 1.5 ext. amp. control
						OPTION: BT_SCL – Bluetooth I <sup>2</sup> C SCL
I2C_SDA	21	1000	PU/PD	IO	HY, 4mA	EEPROM I <sup>2</sup> C IRQ (NC if not used)
						OPTION: BT_RF_ACTIVE – WLAN coex signal
						OPTION: BT_PRIORITY – WLAN coex signal
						OPTION: nEXT_PA_EN – Class 1.5 ext. amp. control
						OPTION: BT_TX_CONFX – WLAN coex signal
						OPTION: BT_SDA – Bluetooth I <sup>2</sup> C SDA
OPTION: DEBUG12 – TI internal						

### 5.3. DEVICE POWER SUPPLY

The CC2560 single chip Bluetooth radio solution is intended to work in devices with a limited power budget such as cellular phones, headsets, hand-held PC's and other battery-operated devices. One of the main differentiators of the CC2560 is its power management – its ability to draw as little current as possible.

The PAN1315 device requires two kinds of power sources:

- Main power supply for the Bluetooth - VDD\_IN = V<sub>BAT</sub>
- Power source for the 1.8 V I/O ring - VDD\_IO

The PAN1315 includes several on-chip voltage regulators for increased noise immunity. The PAN1315 can be connected either directly to the battery or to an external 1.8-V DC to DC converter.

There are three ways to supply power:

- Full-V<sub>BAT</sub> system:

Maximum RF output power, but not optimum system power:

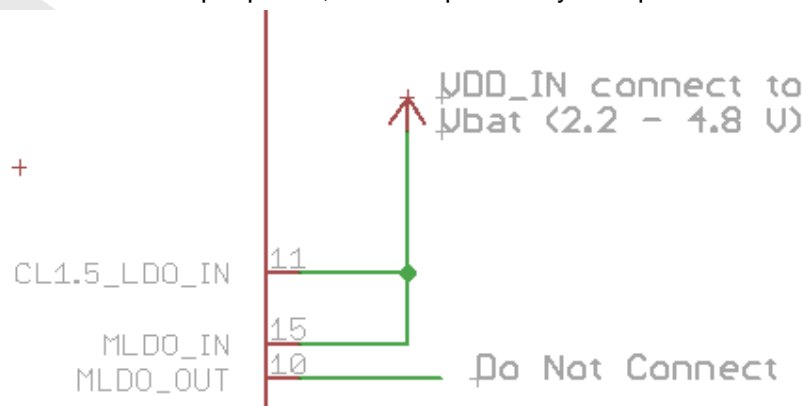



CLASSIFICATION Einstufung	PRODUCT SPECIFICATION Produktspezifikation	No. DS-1315-2400-102	REV. 0.98
SUBJECT Thema	CLASS 2 BLUETOOTH MODULE Bluetooth Modul der Klasse 2	PAGE Seite	9 of 32
CUSTOMER'S CODE PAN1315	PANASONIC'S CODE ENW89818C2JF	DATE Datum	21.04.2009

- Full-DC2DC system:  
Lower RF output power, but optimum system power:

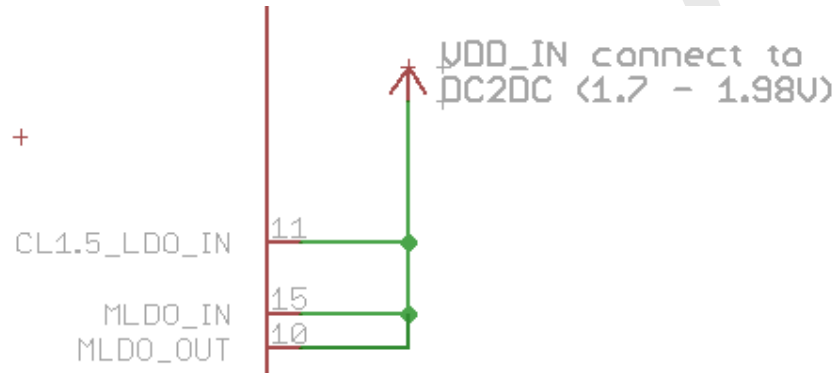

- Mixed DC2DC- $V_{BAT}$  system:  
Maximum RF output power and optimum system power, but requires routing of  $V_{BAT}$ :

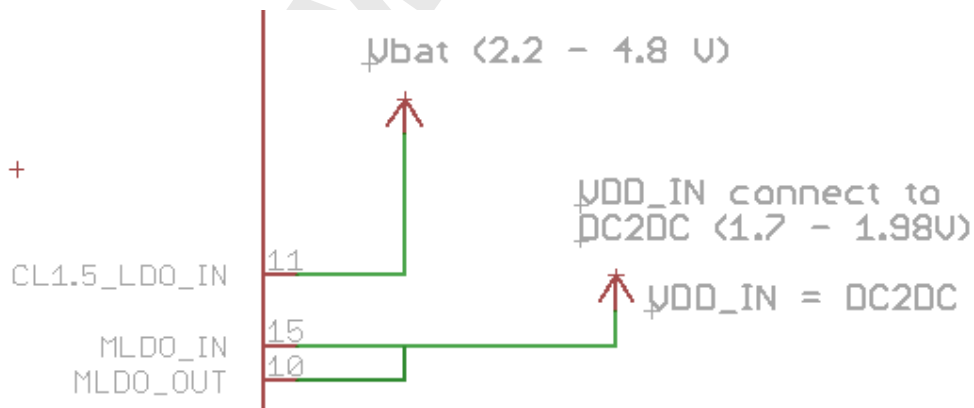

#### 5.4. CLOCK INPUTS

The slow clock is always supplied from an external source. It is connected to the SLOW\_CLK\_IN pin number 8 and can be a digital signal with peak to peak of 0-1.8 V. The slow clock's frequency accuracy must be 32.768 kHz  $\pm$ 250 ppm for Bluetooth usage (according to the Bluetooth specification).

CLASSIFICATION Einstufung	PRODUCT SPECIFICATION Produktspezifikation	No. DS-1315-2400-102	REV. 0.98
SUBJECT Thema	CLASS 2 BLUETOOTH MODULE Bluetooth Modul der Klasse 2	PAGE Seite	10 of 32
CUSTOMER'S CODE PAN1315	PANASONIC'S CODE ENW89818C2JF	DATE Datum	21.04.2009

## 6. BLUETOOTH FEATURES

- Support of Bluetooth2.1+EDR (Lisbon Release) up to HCI level.
- Very fast AFH algorithm for both ACL and eSCO.
- Supports typically 4 dBm Class 2 TX power w/o external PA, improving Bluetooth link robustness. The TX power can be raised up to 10 dBm depending on the host settings.
- Supports multiple Bluetooth profiles with enhanced QoS, both mono and stereo, assisted A2DP (no host processing required).
- Digital Radio Processor (DRP) single-ended 50 Ohm.
- Spurious emissions compatible with GPS applications.
- Internal temperature detection and compensation ensures minimal variation in the RF performance over temperature.
- Flexible PCM and I2S digital audio/voice interfaces: Full flexibility of data-format (Linear, a-Law,  $\mu$ -Law), data-width, data order, sampling and slot positioning, master/slave modes, high clock rates up to 15 MHz for slave mode (or 4.096 MHz for Master Mode). Lost packet concealment for improved audio.
- Proprietary low-power scan method for page and inquiry scans, achieves page and inquiry scans at 1/3rd normal power.
- On board SBC decoder/encoder – offloads host for A2DP and WideBand speech processing. A2DP host burst mode, enhanced dynamic bit pool algorithm.

CLASSIFICATION Einstufung	PRODUCT SPECIFICATION Produktspezifikation	No. DS-1315-2400-102	REV. 0.98
SUBJECT Thema	CLASS 2 BLUETOOTH MODULE Bluetooth Modul der Klasse 2	PAGE Seite	11 of 32
CUSTOMER'S CODE PAN1315	PANASONIC'S CODE ENW89818C2JF	DATE Datum	21.04.2009

## 7. BLOCK DIAGRAM

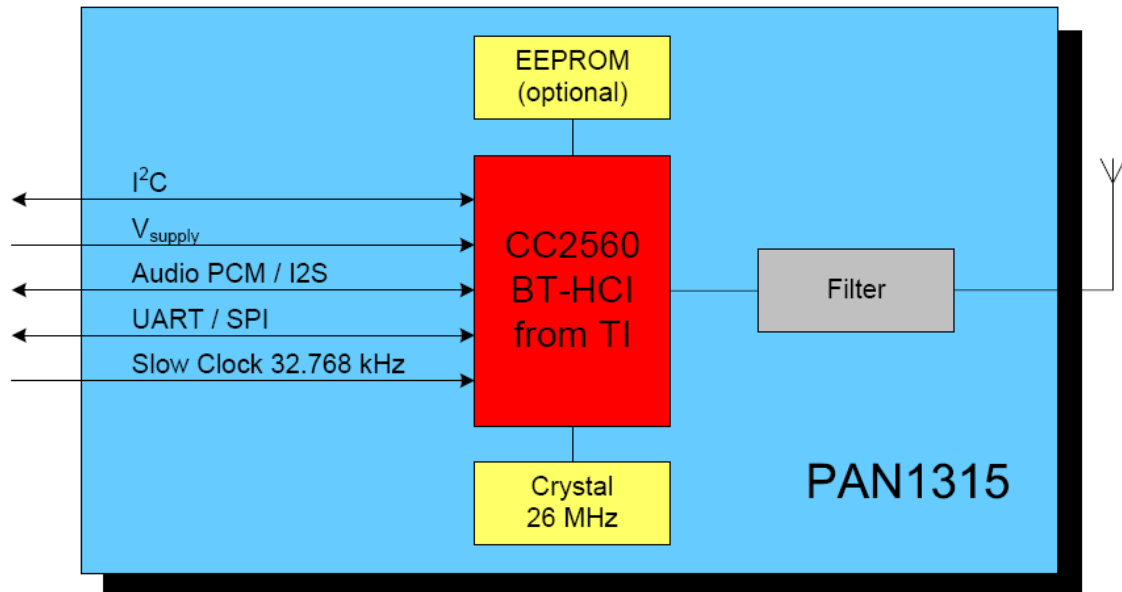

The EEPROM could be used to store some calibration value for the 26 MHz crystal at room temperature, so the max. operating temperature could be increase to +85°C.

In addition, the start up time could be decrease, as the patch can be loaded from the EEPROM, more details will be available in the next revision.

Note: The Slow Clock 32.768 kHz is mandatory, otherwise the module does not start up, please refer to chapter 5.4.

## 8. TEST CONDITIONS

Measurements shall be made under room temperature and humidity unless otherwise specified.

Temperature	25 ± 10°C
Humidity	40 to 85%RH
SW-Patch	V2.30
Supply Voltage	3.3V

## 9. GENERAL DEVICE REQUIREMENTS AND OPERATION

CLASSIFICATION Einstufung	PRODUCT SPECIFICATION Produktspezifikation	No. DS-1315-2400-102	REV. 0.98
SUBJECT Thema	CLASS 2 BLUETOOTH MODULE Bluetooth Modul der Klasse 2	PAGE Seite	12 of 32
CUSTOMER'S CODE PAN1315	PANASONIC'S CODE ENW89818C2JF	DATE Datum	21.04.2009

Actual values are given based on TI datasheet, in the final version it could be adjusted after the final measurements on the Panasonic PAN1315ETU (**E**asy **T**o **U**se) test board, unless otherwise indicated.

All specifications are over temperature and process, unless indicated otherwise.

## 9.1. ABSOLUTE MAXIMUM RATINGS

Over operating free-air temperature range (unless otherwise noted).

### Note

All parameters are measured as follows unless stated otherwise:

$$VDD\_IN^9 = 3.3 \text{ V}, VDD\_IO = 1.8 \text{ V}.$$

No	See <sup>10</sup>	Value	Unit
Ratings Over Operating Free-Air Temperature Range			
1	VDD_IN	Supply voltage range	-0.5 to 5.5 V <sup>11</sup>
2	VDDIO_1.8V		-0.5 to 2.145 V
3	Input voltage to RF (Pin 13)		-0.5 to 2.1 V
4	Operating ambient temperature range		-20 to 70 °C
5	Storage temperature range		-40 to 125 °C
6	Bluetooth RF inputs (Pin 13)		10 dBm

## 9.2. RECOMMENDED OPERATING CONDITIONS

No	Rating	Condition	Symbol	Min	Max	Unit
1	Power supply voltage <sup>12</sup>		VDD_IN	1.7	4.8	V
2	IO power supply voltage		VDD_IO	1.62	1.92	V
3	High-level input voltage	Default	V <sub>IH</sub>	0.65 x VDD_IO	VDD_IO	V

<sup>9</sup> VDD\_IN is supplied to MLDO\_IN (Pin 15) and CL1.5\_LDO\_IN (Pin 11), other options are described in chapter 5.3 Device Power Supply.

<sup>10</sup> Stresses beyond those listed under "absolute maximum ratings" may cause permanent damage to the device. These are stress ratings only and functional operation of the device at these or any other conditions beyond those indicated under "recommended operating conditions" is not implied. Exposure to absolute-maximum-rated conditions for extended periods may affect device reliability.

<sup>11</sup> Maximum allowed depends on accumulated time at that voltage: VDD\_IN is defined in Reference schematics. When DC2DC supply is used, maximum voltage into MLDO\_OUT and FM\_LDO\_IN = 2.145 V.

<sup>12</sup> Excluding 1.98 < VDD\_IN < 2.2 V range – not allowed.

CLASSIFICATION Einstufung	PRODUCT SPECIFICATION Produktspezifikation	No. DS-1315-2400-102	REV. 0.98
SUBJECT Thema	CLASS 2 BLUETOOTH MODULE Bluetooth Modul der Klasse 2	PAGE Seite	13 of 32
CUSTOMER'S CODE PAN1315	PANASONIC'S CODE ENW89818C2JF	DATE Datum	21.04.2009

No	Rating	Condition	Symbol	Min	Max	Unit
4	Low-level input voltage	Default	$V_{IL}$	0	$0.35 \times VDD_{IO}$	V
5	IO1/IO2 Input rise/fall times, 10% to 90% <sup>13</sup>		Tr/Tf	0	25	ns
6	Maximum ripple on VDD_IN (Sine wave) for 1.8 V (DC2DC) mode	0 to 0.1 MHz			60	mVp-p
		0.1 to 0.5 MHz			50	
		0.5 to 2.5 MHz			30	
		2.5 to 3.0 MHz			15	
		> 3.0 MHz			5	
7	Voltage dips on VDD_IN ( $V_{BAT}$ ) (due to GSM polling: duration = 577 $\mu$ s to 2.31 ms, period = 4.6 ms)				400	mV
8	Maximum ambient operating temperature <sup>14</sup>				70	$^{\circ}$ C

### 9.3. CURRENT CONSUMPTION

No	Characteristics	Min 25 $^{\circ}$ C	Typ 25 $^{\circ}$ C	Max 25 $^{\circ}$ C	Min -20 $^{\circ}$ C	Typ -20 $^{\circ}$ C	Max -20 $^{\circ}$ C	Min +70 $^{\circ}$ C	Typ +70 $^{\circ}$ C	Max +70 $^{\circ}$ C	Unit
1	Current consumption in shutdown mode <sup>15</sup>		1	3						7	$\mu$ A
2	Current consumption in deep sleep mode <sup>16</sup>		40	105						700	$\mu$ A
3	Total IO current consumption for active mode			1			1			1	mA

### 9.4. GENERAL ELECTRICAL CHARACTERISTICS

No	Rating	Condition	Min	Max	Value		
1	High-level output voltage, $V_{OH}$	at 2/4/8 mA	$0.8 \times VDD_{IO}$	$VDD_{IO}$	V		
		at 0.1 mA	$VDD_{IO} - 0.2$	$VDD_{IO}$	V		
2	Low-level output voltage, $V_{OL}$	at 2/4/8 mA	0	$0.2 \times VDD_{IO}$	V		
		at 0.1 mA	0	0.2	V		
3	IO input impedance	Resistance	1		M $\Omega$		
		Capacitance		5	pF		
4	Output rise/fall times, 10% to 90% (Digital pins)	$C_L = 20$ pF		10	ns		
5	IO pull currents	TX_DBG, IO2, PCM bus	PU	typ = 6.5	3.5	9.7	$\mu$ A
			PD	typ = 27	9.5	55	
		All others	PU	typ = 100	100	300	$\mu$ A
			PD	typ = 100	100	360	

<sup>13</sup> Excluding SPI\_CLK on IO1: max = 5 ns.

<sup>14</sup> The device can be reliably operated for 7 years at  $T_{ambient}$  of 70 $^{\circ}$ C, assuming 25% active mode and 75% sleep mode (15,400 cumulative active power-on hours).

<sup>15</sup>  $V_{bat} + V_{io}$

<sup>16</sup>  $V_{bat} + V_{io} + V_{sd}$  (shutdown)

CLASSIFICATION Einstufung	PRODUCT SPECIFICATION Produktspezifikation	No. DS-1315-2400-102	REV. 0.98
SUBJECT Thema	CLASS 2 BLUETOOTH MODULE Bluetooth Modul der Klasse 2	PAGE Seite	14 of 32
CUSTOMER'S CODE PAN1315	PANASONIC'S CODE ENW89818C2JF	DATE Datum	21.04.2009

## 9.5. NSHUTD REQUIREMENTS

No	Parameter	Symbol	Min	Max	Unit
1	Operation mode level <sup>17</sup>	V <sub>IH</sub>	1.42	1.98	V
2	Shutdown mode level <sup>1</sup>	V <sub>IL</sub>	0	0.4	V
3	Minimum time for nSHUT_DOWN low to reset the device		5		ms
4	Rise/fall times	Tr/Tf		20	µs

## 9.6. EXTERNAL DIGITAL SLOW CLOCK REQUIREMENTS (–20°C TO +70°C)

No	Characteristics	Condition	Symbol	Min	Typ	Max	Unit
1	Input slow clock frequency				32768		Hz
2	Input slow clock accuracy (Initial + temp + aging)	Bluetooth				±250	ppm
3	Input transition time Tr/Tf – 10% to 90%		Tr/Tf			100	ns
4	Frequency input duty cycle			15%	50%	85%	
5	Phase noise	at 1 kHz				-125	dBc/Hz
6	Jitter	Integrated over 300 to 15000 Hz				1	Hz
7	Slow clock input voltage limits	Square wave, DC coupled	V <sub>IH</sub>	0.65 x VDD_IO		VDD_IO	V peak
			V <sub>IL</sub>	0		0.35 x VDD_IO	
8	Input impedance			1			MΩ
9	Input capacitance					5	pF

<sup>17</sup> Internal pull down retains shut down mode when no external signal is applied to this pin.

CLASSIFICATION Einstufung	PRODUCT SPECIFICATION Produktspezifikation	No. DS-1315-2400-102	REV. 0.98
SUBJECT Thema	CLASS 2 BLUETOOTH MODULE Bluetooth Modul der Klasse 2	PAGE Seite	15 of 32
CUSTOMER'S CODE PAN1315	PANASONIC'S CODE ENW89818C2JF	DATE Datum	21.04.2009

## 10. BLUETOOTH RF PERFORMANCE (BT)

Actual values are given based on TI datasheet, in the final version it could be adjusted after the final measurements on the Panasonic PAN1315ETU (**E**asy **T**o **U**se) test board, unless otherwise indicated.

### 10.1. BLUETOOTH RECEIVER CHARACTERISTICS – IN-BAND SIGNALS

No	Characteristics	Condition	Min	Typ	Max	BT Spec	Unit
1	Operation frequency range		2402		2480		MHz
2	Channel spacing			1			MHz
3	Input impedance			50			$\Omega$
4	Sensitivity, Dirty Tx on <sup>18</sup>	GFSK, BER = 0.1%	-89.5	-93.0		-70	dBm
		Pi/4-DQPSK, BER = 0.01%	-88.5	-92.5		-70	
		8DPSK, BER = 0.01%	-81.0	-85.5		-70	
		Pi/4-DQPSK and 8DPSK, BER error floor at sensitivity + 10 dB, dirty Tx off.					
		Pi/4-DQPSK	1E-6	<1E-7		1E-5	
		8DPSK	1E-6			1E-5	
5	Maximum useable input power	GFSK, BER = 0.1%	-5				dBm
		Pi/4-DQPSK, BER = 0.1%	-10			-20	
		8DPSK, BER = 0.1%	-10				
6	Intermodulation characteristics	Level of interferers For n = 3, 4, and 5	-36	-30		-39	dBm
7	C/I performance  Note: Numbers show desired-signal to interfering-signal ratio. Smaller numbers indicate better C/I performance.  Image = -1 MHz	GFSK, Co-channel		8.0	10	11	dB
		EDR, Co-channel	Pi/4-DQPSK	9.5	11	13	
			8DPSK	16.5	20	21	
		GFSK, adjacent $\pm 1$ MHz		-10	-5	0	
		EDR, adjacent $\pm 1$ MHz, (image)	Pi/4-DQPSK	-10	-5	0	
			8DPSK	-5	-1	5	
		GFSK, adjacent +2 MHz		-38	-35	-30	
		EDR, adjacent -2 MHz	Pi/4-DQPSK	-38	-35	-30	
			8DPSK	-38	-30	-25	
		GFSK, adjacent -2 MHz		-28	-20	-20	
		EDR, adjacent -2 MHz	Pi/4-DQPSK	-28	-20	-20	
			8DPSK	-22	-13	-13	
GFSK, adjacent $\geq  \pm 3 $ MHz		-45	-43	-40			
EDR, adjacent $\geq  \pm 3 $ MHz	Pi/4-DQPSK	-45	-43	-40			
	8DPSK	-44	-36	-33			
8	RF return loss			-10			dB
9	RX mode LO leakage	F <sub>rf</sub> (= received RF freq. - 0.6 MHz)		-65	-60		dBm

<sup>18</sup> Sensitivity degradation up to 3dB may occur for minimum and typical values where the Bluetooth frequency is a harmonic of the fast clock.

CLASSIFICATION Einstufung	PRODUCT SPECIFICATION Produktspezifikation	No. DS-1315-2400-102	REV. 0.98
SUBJECT Thema	CLASS 2 BLUETOOTH MODULE Bluetooth Modul der Klasse 2	PAGE Seite	16 of 32
CUSTOMER'S CODE PAN1315	PANASONIC'S CODE ENW89818C2JF	DATE Datum	21.04.2009

## 10.2. BLUETOOTH RECEIVER CHARACTERISTICS – GENERAL BLOCKING

No	Characteristics	Condition	Min	Typ	Unit
1	Blocking performance over full range, according to Bluetooth specification <sup>19</sup>	30 to 2000 MHz	-6		dBm
		2000 to 2399 MHz	-6		
		2484 to 3000 MHz	-6		
		3 to 12.75 GHz	-6		

## 10.3. BLUETOOTH RECEIVER CHARACTERISTICS – GFSK/EDR2/EDR3 Blocking Per Band

No	Characteristics	Condition	Min	Typ	Unit
1	FM band blocking	76 to 108 MHz	0		dBm
2	Blocking performance for various cellular standards  Hopping on desired signal: 3dB from sensitivity with modulated continuous blocking signal GFSK BER = 0.1% EDR BER = 0.01% PER = 1%	776 to 794 MHz (CDMA)	-19	-14	dBm
		824 to 849 MHz (GMSK) <sup>20</sup>	-16	-5	
		824 to 849 MHz (EDGE) <sup>2</sup>	-19	-13	
		824 to 849 MHz (CDMA) <sup>2</sup>	-20	-14	
		880 to 915 MHz (GMSK)	-25	-16	
		880 to 915 MHz (EDGE)	-26	-17	
		1710 to 1785 MHz (GMSK)	-10	-6	
		1710 to 1785 MHz (EDGE)	-25	-20	
		1850 to 1910 MHz (GMSK)	-25	-20	
		1850 to 1910 MHz (EDGE)	-31	-22	
		1850 to 1910 MHz (CDMA)	-30	-22	
1850 to 1910 MHz (WCDMA)	-28	-18			
1920 to 1980 MHz (WCDMA)	-25	-19			

## 10.4. BLUETOOTH TRANSMITTER, GFSK, FULL OUTPUT

No	Characteristics	Min	Typ	Max	BT Spec	Unit
1	RF output power	VDD_IN = V <sub>BAT</sub>	9	10.5		dBm
		VDD_IN = ext. reg.	6	8		
2	Power variation over Bluetooth band	-1		1		dB
3	Gain Control Range		30			dB
4	Power Control Step	2	4	8	2 to 8	dB
5	Adjacent Channel Power  M-N  = 2		-45	-42	≤ -20	dBm
6	Adjacent Channel Power  M-N  > 2		-50	-42	≤ -40	dBm

<sup>19</sup> 10 exceptions out of the total 24 allowed in the Bluetooth specification.

<sup>20</sup> Except for frequencies where [3 \* F\_BLOCKER] falls within the Bluetooth band (2400 to 2483.5 MHz).



CLASSIFICATION Einstufung	PRODUCT SPECIFICATION Produktspezifikation	No. DS-1315-2400-102	REV. 0.98
SUBJECT Thema	CLASS 2 BLUETOOTH MODULE Bluetooth Modul der Klasse 2	PAGE Seite	17 of 32
CUSTOMER'S CODE PAN1315	PANASONIC'S CODE ENW89818C2JF	DATE Datum	21.04.2009

### 10.5. BLUETOOTH TRANSMITTER, EDR, FULL OUTPUT

No	Characteristics			Min 25°C, -20°C	Typ 25°C, -20°C	Max 25°C, -20°C	Min +70°C	Typ +70°C	Max +70°C	Bluetooth Spec	Unit
1	EDR output power	Pi/4- DQPSK	CL1.5_LDO_IN = V <sub>BAT</sub>	8.0	10		8.0	10			dBm
			CL1.5_LDO_IN = DC2DC	8.0	10		7.5	10			
	8DPSK	CL1.5_LDO_IN = V <sub>BAT</sub>	8.0	10		8.0	10				
		CL1.5_LDO_IN = DC2DC	8.0	10		7.5	10				
2	EDR rel power <sup>21</sup>			-2		1	-2		1	-4 to +1	dB
3	Power variation over Bluetooth band			-1		1	-1		1		
4	Gain Control Range <sup>1</sup>			30			30				
5	Power Control Step <sup>1</sup>			2	4	8	2	4	8	2 to 8	
6	Adjacent Channel Power  M-N  = 1 <sup>1</sup>				-36	-30		-36	-30	≤ -26	dBc
7	Adjacent Channel Power  M-N  = 2 <sup>1,22</sup>				-30	-23		-30	-23	≤ -20	dBm
8	Adjacent Channel Power  M-N  > 2 <sup>1,2</sup>				-42	-40		-42	-40	≤ -40	dBm

### 10.6. BLUETOOTH MODULATION, GFSK, FULL OUTPUT

No	Characteristics	Condition	Symbol	Min	Typ	Max	BT Spec.	Unit
1	-20 dB BW	GFSK			925	995	≤ 1000	kHz
2	Average deviation Detector bandwidth – 10MHz	Mod Data = 4-1, 4-0 1111000011110000...	F1 avg	150	165	170	140 to 175	kHz
3	Instantaneous deviation	Mod data = 1010101...	F2 max	120	130		> 115	kHz
4	dF2/dF1			85%	88%		> 80%	
5	Absolute carrier frequency drift	DH1		-25		25	< ±25	kHz
		DH3 and DH5		-35		35	< ±40	kHz
6	Drift Rate					15	< 20	kHz/50µs
7	Initial Carrier Frequency Tolerance					±25	< ±75	kHz

<sup>21</sup> For both Pi/4-DQPSK and 8DPSK

<sup>22</sup> As the used internal filter has 2dB insertion loss

CLASSIFICATION Einstufung	PRODUCT SPECIFICATION Produktspezifikation	No. DS-1315-2400-102	REV. 0.98
SUBJECT Thema	CLASS 2 BLUETOOTH MODULE Bluetooth Modul der Klasse 2	PAGE Seite	18 of 32
CUSTOMER'S CODE PAN1315	PANASONIC'S CODE ENW89818C2JF	DATE Datum	21.04.2009

### 10.7. BLUETOOTH MODULATION, EDR, FULL OUTPUT

No	Characteristics	Condition	Min	Typ	Max	BT Spec.	Unit
1	Carrier frequency stability			±3	±10	≤10	kHz
2	Initial Carrier Frequency Tolerance				±10	±75	kHz
3	Rms DEVM <sup>23</sup>	Pi/4-DQPSK		6%	15%	20%	
		8DPSK		6%	13%	13%	
4	99% DEVM <sup>1</sup>	Pi/4-DQPSK			30%	30%	
		8DPSK			20%	20%	
5	Peak DEVM <sup>1</sup>	Pi/4-DQPSK		14%	30%	35%	
		8DPSK		16%	25%	25%	

### 10.8. BLUETOOTH TRANSMITTER, OUT-OF-BAND EMISSIONS

No	Characteristics	Condition	Typ	Max	Unit
1	Tx and Rx out-of-band emissions Output signal = 10 dBm	76 to 108 MHz (FM)		-100	dBm/Hz
		746 to 764 MHz (CDMA)	-151	-147	
		869 to 894 MHz (CDMA1, GSM)	-150	-145	
		925 to 960 MHz (E-GSM)	-148	-145	
		1570 to 1580 MHz (GPS)	-145	-138	
		1820 to 1880 MHz (GSM)	-145	-142	
		1930 to 1990 MHz (GSM, CDMA1, WCDMA)	-147	-145	
		2110 to 2170 MHz (WCDMA)	-145	-143	
		30 kHz to 1 GHz <sup>24, 25</sup>		-67	dBm
1 to 12.75 GHz <sup>2, 3</sup>	-51.5	-41			
2	2nd harmonic	at 8dBm power <sup>3</sup>	-32	-30	dBm
3	3rd harmonic	at 8dBm power <sup>3</sup>	-32	-30	dBm

<sup>23</sup> Max performance refers to Max TX power.

<sup>24</sup> Includes effects of frequency hopping

<sup>25</sup> Measured with the internal filter on the module, so it will also meets FCC and ETSI requirements.

CLASSIFICATION Einstufung	PRODUCT SPECIFICATION Produktspezifikation	No. DS-1315-2400-102	REV. 0.98
SUBJECT Thema	CLASS 2 BLUETOOTH MODULE Bluetooth Modul der Klasse 2	PAGE Seite	19 of 32
CUSTOMER'S CODE PAN1315	PANASONIC'S CODE ENW89818C2JF	DATE Datum	21.04.2009

## 11. SOLDERING TEMPERATURE-TIME PROFILE (FOR REFLOW SOLDERING)

### 11.1. FOR LEAD SOLDER

#### Recommended temp. profile for reflow soldering

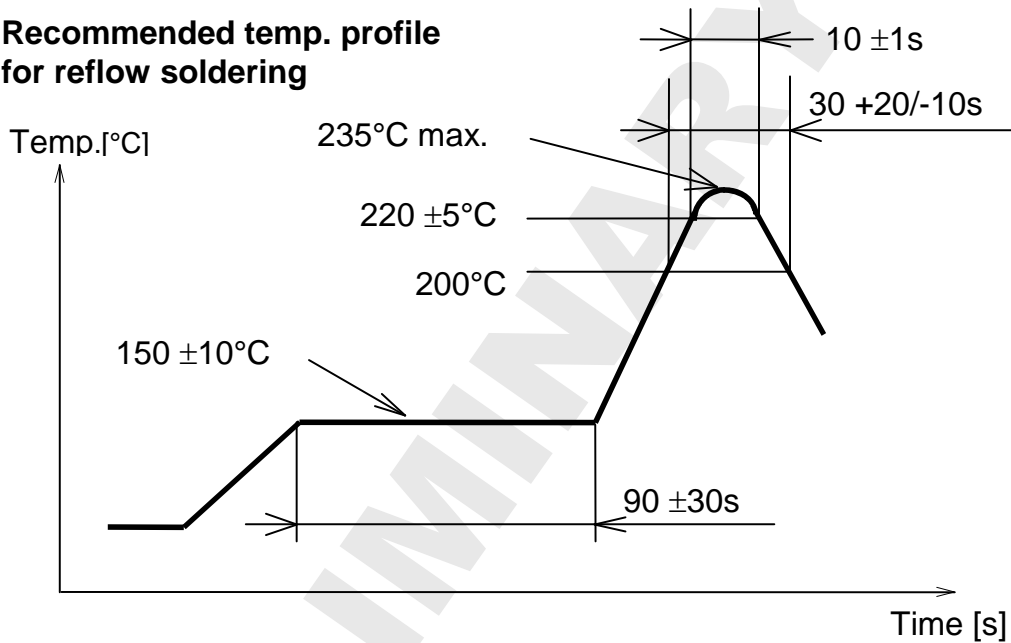

### 11.2. FOR LEADFREE SOLDER

#### Our used temp. profile for reflow soldering

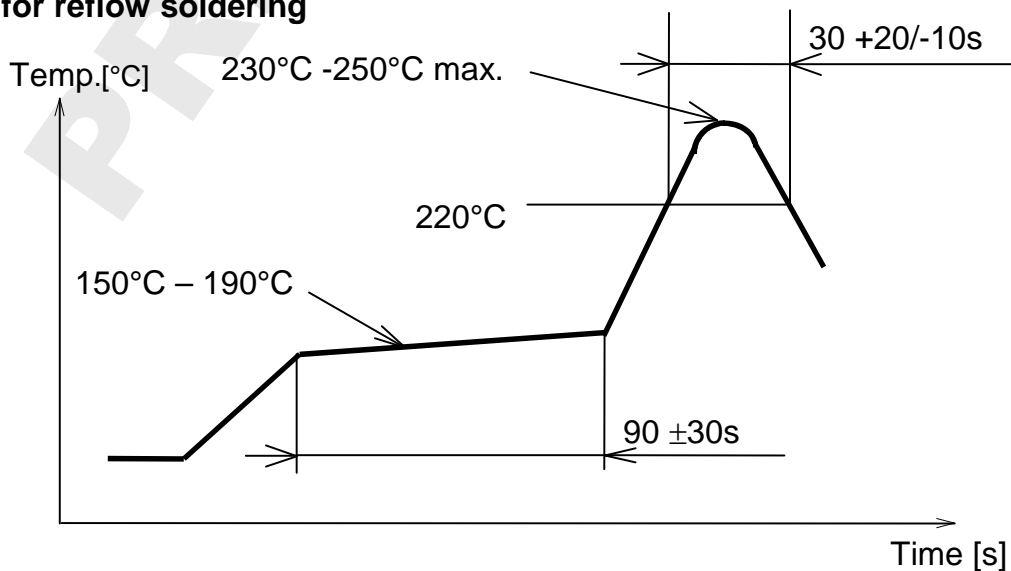

Reflow permissible cycle: 2  
 Opposite side reflow is prohibited due to module weight.

CLASSIFICATION Einstufung	PRODUCT SPECIFICATION Produktspezifikation	No. DS-1315-2400-102	REV. 0.98
SUBJECT Thema	CLASS 2 BLUETOOTH MODULE Bluetooth Modul der Klasse 2	PAGE Seite	20 of 32
CUSTOMER'S CODE PAN1315	PANASONIC'S CODE ENW89818C2JF	DATE Datum	21.04.2009

## 12. MODULE DIMENSION

No.	Item	Dimension	Tolerance	Remark
1	Width	6.50	± 0.20	
2	Lenght	9.00	± 0.20	
3	Height	1.80	± 0.10	With case

## 13. FOOTPRINT OF THE MODULE

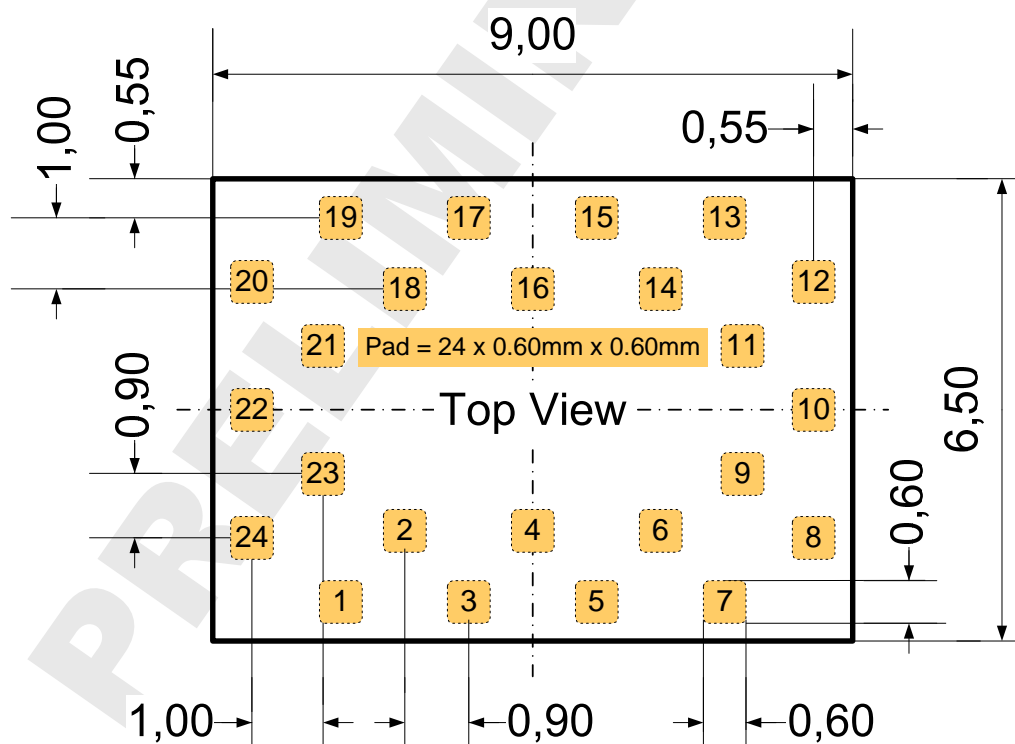

All dimensions are in millimeters.  
The outer dimensions have a tolerance of  $\pm 0.2\text{mm}$ .

CLASSIFICATION Einstufung	PRODUCT SPECIFICATION Produktspezifikation	No. DS-1315-2400-102	REV. 0.98
SUBJECT Thema	CLASS 2 BLUETOOTH MODULE Bluetooth Modul der Klasse 2	PAGE Seite	21 of 32
CUSTOMER'S CODE PAN1315	PANASONIC'S CODE ENW89818C2JF	DATE Datum	21.04.2009

## 14. LABELLING DRAWING

### 14.1. ENGINEERING SAMPLES

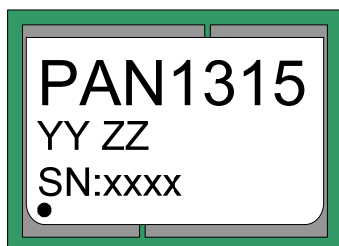

Above white carbon label is suitable for reflow soldering and designed for the engineering sample status.

The point on the label (below left) is the identifier for pin 1 of the module.

As a summary:

Print	Description
xxxx	Serial Number
YY	Hardware Identifier:
	EE With EEPROM
	00 Without EEPROM
ZZ	Software Identifier:
	01 first identifier for the software version

### 14.2. MASS PRODUCTION

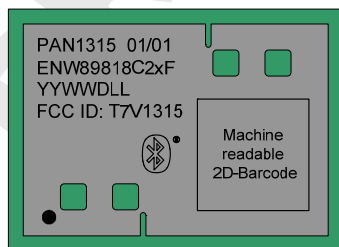

This will be a laser marking on the top case, drawing is only an example.

## 15. MECHANICAL REQUIREMENTS

No.	Item	Limit	Condition
1	Solderability	More than 75% of the soldering area shall be coated by solder	Reflow soldering with recommendable temperature profile
2	Resistance to soldering heat	It shall be satisfied electrical requirements and not be mechanical damage	See chapter 11.2

CLASSIFICATION Einstufung	PRODUCT SPECIFICATION Produktspezifikation	No. DS-1315-2400-102	REV. 0.98
SUBJECT Thema	CLASS 2 BLUETOOTH MODULE Bluetooth Modul der Klasse 2	PAGE Seite	22 of 32
CUSTOMER'S CODE PAN1315	PANASONIC'S CODE ENW89818C2JF	DATE Datum	21.04.2009

## 16. RECOMMENDED FOOT PATTERN

Dimensions in mm.

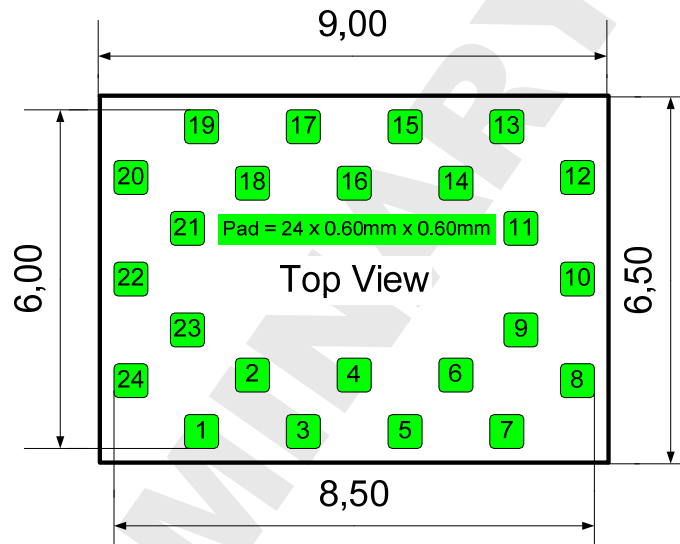

In comparison to the module we recommend to use 50  $\mu$ m bigger pad size to each direction

The land pattern dimensions above are meant to serve only as a guide. This information is provided without any legal liability.

For the footprint, it is recommended to incorporate a 50 $\mu$ m bigger size for the pads in each direction compared to the module footprint. Please refer to chapter 17, Foot Print of the Module.

For the solder paste screen, use the same screen for the module. Solder paste screen cutouts (with slightly different dimensions) might be optimum depending on your soldering process. For example, the solder paste screen thickness chosen might have an effect. The solder screen thickness depends on your production standard -- 120 $\mu$ m to 150 $\mu$ m is recommended.

### IMPORTANT:

Although the bottom side of PAN1315 is fully coated, no copper such as through hole vias, planes or tracks on the board component layer should be located below the PAN1315 to avoid creating a short. In cases where a track or through hole via has to be located under the module, please make a note that it has to be kept away from PAN1315 bottom pads. The PAN1315 multilayer pcb contains an inner RF shielding plane, therefore no pcb shielding plane below the module is needed.

When using an onboard ceramic antenna, please place the antenna on the edge of your carrier board (if allowable).

If you have any questions on these points, please contact your local Panasonic representative.

Before releasing the layout, we recommend to sent the schematic and layout for final check to [wireless@eu.panasonic.com](mailto:wireless@eu.panasonic.com).

CLASSIFICATION Einstufung	PRODUCT SPECIFICATION Produktspezifikation	No. DS-1315-2400-102	REV. 0.98
SUBJECT Thema	CLASS 2 BLUETOOTH MODULE Bluetooth Modul der Klasse 2	PAGE Seite	23 of 32
CUSTOMER'S CODE PAN1315	PANASONIC'S CODE ENW89818C2JF	DATE Datum	21.04.2009

## 17. DEVELOPMENT OF APPLICATIONS

Mindtree Ltd. has developed Bluetooth software, including some profiles, for TIs MSP430 and Panasonics PAN1315. A detailed documentation will be available in the next revision of this document, in Related Documents, Chapter 25. Also refer to [www.panasonic.com/rfmodules](http://www.panasonic.com/rfmodules)

### 17.1. TOOLS TO BE NEEDED

MSP-EXP430F5438 - Experimenter Board, which can be ordered [here](http://focus.ti.com/docs/toolsw/folders/print/msp-exp430f5438.html):

<http://focus.ti.com/docs/toolsw/folders/print/msp-exp430f5438.html>

MSP-FET430UIF430 - Debugging Interface, which can be ordered [here](http://focus.ti.com/docs/toolsw/folders/print/msp-fet430uif.html):

<http://focus.ti.com/docs/toolsw/folders/print/msp-fet430uif.html>

PAN1315EMK - Bluetooth Evaluation Module Kit for MSP430, which can be ordered here:

TI link:

[http://focus.ti.com/docs/toolsw/folders/print/pan1315emk.html?DCMP=wtbu\\_ecs&HQS=EVM+O+pan1315emk](http://focus.ti.com/docs/toolsw/folders/print/pan1315emk.html?DCMP=wtbu_ecs&HQS=EVM+O+pan1315emk)

Panasonic link:

<http://www.panasonic.com/industrial/electronic-components/rf-modules/bluetooth/pan1315etu.aspx>

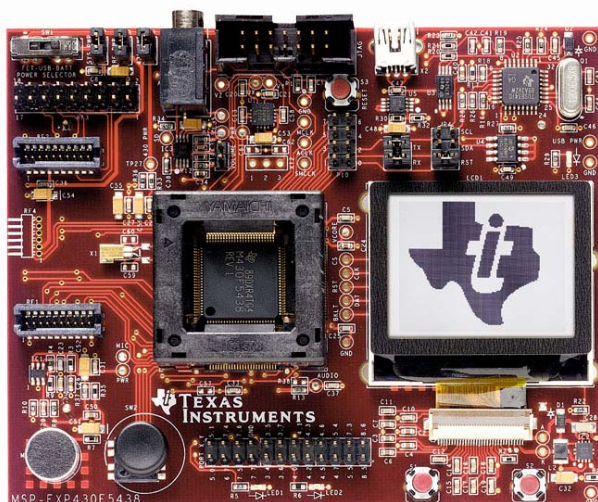

MSP-EXP430F5438  
MSP430F5438 Experimenter Board

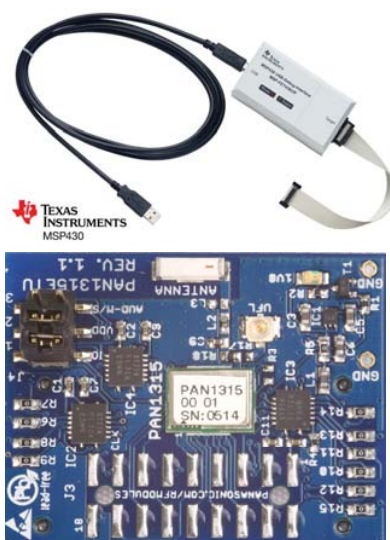

PAN1315ETU

In addition you need the software development environment, e.g. IAR Embedded Workbench, please refer to [2].

For a detailed description of the usage for the tools refer to:

[http://wiki.msp430.com/index.php/MSP430\\_Bluetooth\\_Platform](http://wiki.msp430.com/index.php/MSP430_Bluetooth_Platform)

Evaluation kits and modules are available through Panasonic's network of authorized distributors. For additional information visit [www.panasonic.com/rfmodules](http://www.panasonic.com/rfmodules).

CLASSIFICATION Einstufung	PRODUCT SPECIFICATION Produktspezifikation	No. DS-1315-2400-102	REV. 0.98
SUBJECT Thema	CLASS 2 BLUETOOTH MODULE Bluetooth Modul der Klasse 2	PAGE Seite	24 of 32
CUSTOMER'S CODE PAN1315	PANASONIC'S CODE ENW89818C2JF	DATE Datum	21.04.2009

## 18. RELIABILITY TESTS

The measurement should be done after being exposed to room temperature and humidity for 1 hour.

No.	Item	Limit	Condition
1	Vibration test	Electrical parameter should be in specification	a) Freq.:10~50Hz,Amplitude:1.5mm a) 20min. / cycle,1hrs. each of XYZ axis b) Freq.:30~100Hz, 6G b) 20min. / cycle,1hrs. each of XYZ axis
2	Shock test	the same as above	Dropped onto hard wood from height of 50cm for 3 times
3	Heat cycle test	the same as above	-40°C for 30min. and +85°C for 30min.; each temperature 300 cycles
4	Moisture test	the same as above	+60°C, 90% RH, 300h
5	Low temp. test	the same as above	-40°C, 300h
6	High temp. test	the same as above	+85°C, 300h

## 19. CAUTIONS

Failure to follow the guidelines set forth in this document may result in degrading of the product's functions and damage to the product.

### 19.1. DESIGN NOTES

- (1) Please follow the conditions written in this specification, especially the control signals of this module.
- (2) The supply voltage has to be free of AC ripple voltage (for example from a battery or a low noise regulator output). For noisy supply voltages, provide a decoupling circuit (for example a ferrite in series connection and a bypass capacitor to ground of at least 47uF directly at the module).
- (3) This product should not be mechanically stressed when installed.
- (4) Keep this product away from heat. Heat is the major cause of decreasing the life of these products.
- (5) Avoid assembly and use of the target equipment in conditions where the products' temperature may exceed the maximum tolerance.
- (6) The supply voltage should not be exceedingly high or reversed. It should not carry noise and/or spikes.
- (7) Keep this product away from other high frequency circuits.

### 19.2. INSTALLATION NOTES

- (1) Reflow soldering is possible twice based on the conditions in chapter 15. Set up the temperature at the soldering portion of this product according to this reflow profile.
- (2) Carefully position the products so that their heat will not burn into printed circuit boards or affect the other components that are susceptible to heat.
- (3) Carefully locate these products so that their temperatures will not increase



CLASSIFICATION Einstufung	PRODUCT SPECIFICATION Produktspezifikation	No. DS-1315-2400-102	REV. 0.98
SUBJECT Thema	CLASS 2 BLUETOOTH MODULE Bluetooth Modul der Klasse 2	PAGE Seite	25 of 32
CUSTOMER'S CODE PAN1315	PANASONIC'S CODE ENW89818C2JF	DATE Datum	21.04.2009

- due to the effects of heat generated by neighboring components.
- (4) If a vinyl-covered wire comes into contact with the products, then the cover will melt and generate toxic gas, damaging the insulation. Never allow contact between the cover and these products to occur.
  - (5) This product should not be mechanically stressed or vibrated when reflowed.
  - (6) If you want to repair your board by hand soldering, please keep the conditions of this chapter.
  - (7) Do not wash this product.
  - (8) Refer to the recommended pattern when designing a board.
  - (9) Pressing on parts of the metal cover or fastening objects to the metal will cause damage to the unit.

### 19.3. USAGE CONDITIONS NOTES

- (1) Take measures to protect the unit against static electricity.  
If pulses or other transient loads (a large load applied in a short time) are applied to the products, check and evaluate their operation before assembly on the final products.
- (2) Do not use dropped products.
- (3) Do not touch, damage or soil the pins.
- (4) Follow the recommended condition ratings about the power supply applied to this product.
- (5) Electrode peeling strength: Do not add pressure of more than 4.9N when soldered on PCB.
- (6) Pressing on parts of the metal cover or fastening objects to the metal cover will cause damage.
- (7) These products are intended for general purpose and standard use in general electronic equipment, such as home appliances, office equipment, information and communication equipment.

### 19.4. STORAGE NOTES

- (1) The module should not be stressed mechanically during storage.
- (2) Do not store these products in the following conditions or the performance characteristics of the product, such as RF performance will be adversely affected:
  - Storage in salty air or in an environment with a high concentration of corrosive gas, such as Cl<sub>2</sub>, H<sub>2</sub>S, NH<sub>3</sub>, SO<sub>2</sub>, or NO<sub>x</sub>
  - Storage in direct sunlight
  - Storage in an environment where the temperature may be outside the range of 5°C to 35°C range, or where the humidity may be outside the 45 to 85% range.
  - Storage of the products for more than one year after the date of delivery  
Storage period: Please check the adhesive strength of the embossed tape and soldering after 6 months of storage.
- (3) Keep this product away from water, poisonous gas and corrosive gas.
- (4) This product should not be stressed or shocked when transported.
- (5) Follow the specification when stacking packed crates (max. 10).

CLASSIFICATION Einstufung	PRODUCT SPECIFICATION Produktspezifikation	No. DS-1315-2400-102	REV. 0.98
SUBJECT Thema	CLASS 2 BLUETOOTH MODULE Bluetooth Modul der Klasse 2	PAGE Seite	26 of 32
CUSTOMER'S CODE PAN1315	PANASONIC'S CODE ENW89818C2JF	DATE Datum	21.04.2009

## 19.5. SAFETY CAUTIONS

These specifications are intended to preserve the quality assurance of products and individual components.

Before use, check and evaluate the operation when mounted on your products. Abide by these specifications, without deviation when using the products. These products may short-circuit. If electrical shocks, smoke, fire, and/or accidents involving human life are anticipated when a short circuit occurs, then provide the following failsafe functions, as a minimum.

- (1) Ensure the safety of the whole system by installing a protection circuit and a protection device.
- (2) Ensure the safety of the whole system by installing a redundant circuit or another system to prevent a single fault causing an unsafe status.

## 19.6. OTHER CAUTIONS

- (1) This specification sheet is copyrighted. Please do not disclose it to a third party.
- (2) Please do not use the products for other purposes than those listed.
- (3) Be sure to provide an appropriate fail-safe function on your product to prevent an additional damage that may be caused by the abnormal function or the failure of the product.
- (4) This product has been manufactured without any ozone chemical controlled under the Montreal Protocol.
- (5) These products are not intended for other uses, other than under the special conditions shown below. Before using these products under such special conditions, check their performance and reliability under the said special conditions carefully to determine whether or not they can be used in such a manner.
  - In liquid, such as water, salt water, oil, alkali, or organic solvent, or in places where liquid may splash.
  - In direct sunlight, outdoors, or in a dusty environment
  - In an environment where condensation occurs.
  - In an environment with a high concentration of harmful gas (e.g. salty air, HCl, Cl<sub>2</sub>, SO<sub>2</sub>, H<sub>2</sub>S, NH<sub>3</sub>, and NO<sub>X</sub>)
- (6) If an abnormal voltage is applied due to a problem occurring in other components or circuits, replace these products with new products because they may not be able to provide normal performance even if their electronic characteristics and appearances appear satisfactory.
- (7) When you have any question or uncertainty, contact Panasonic.

CLASSIFICATION Einstufung	PRODUCT SPECIFICATION Produktspezifikation	No. DS-1315-2400-102	REV. 0.98
SUBJECT Thema	CLASS 2 BLUETOOTH MODULE Bluetooth Modul der Klasse 2	PAGE Seite	27 of 32
CUSTOMER'S CODE PAN1315	PANASONIC'S CODE ENW89818C2JF	DATE Datum	21.04.2009

## 20. PACKAGING

If the product has mass production status, indicated in chapter 23, we will deliver the module in the package which are described below.

### 20.1. TAPE DIMENSION

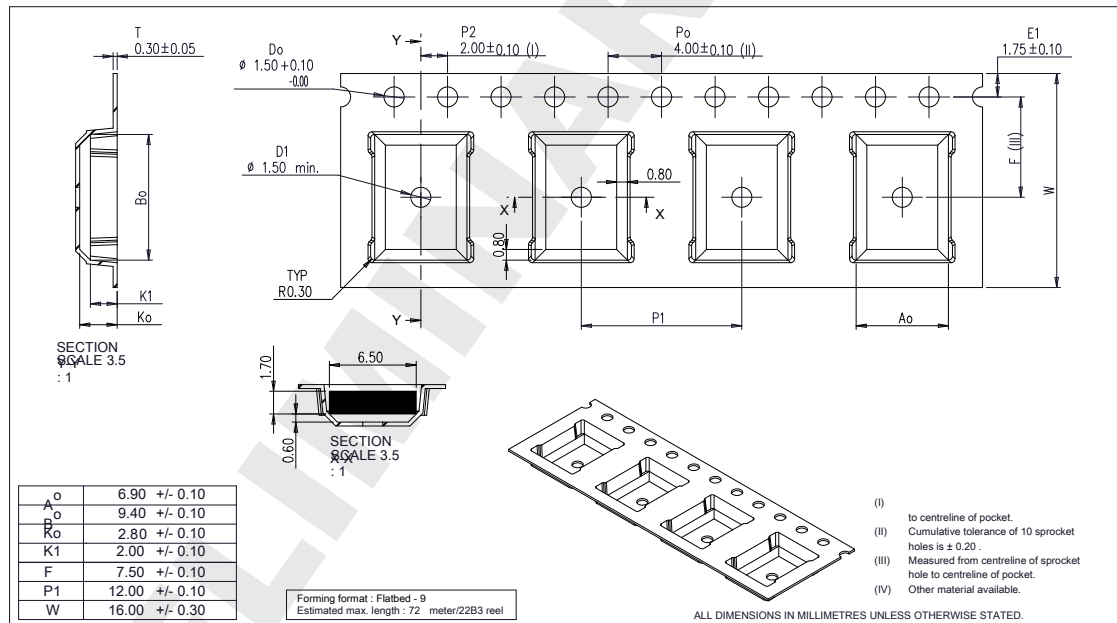

### 20.2. PACKING IN TAPE

Direction of unreeling (for customer) →

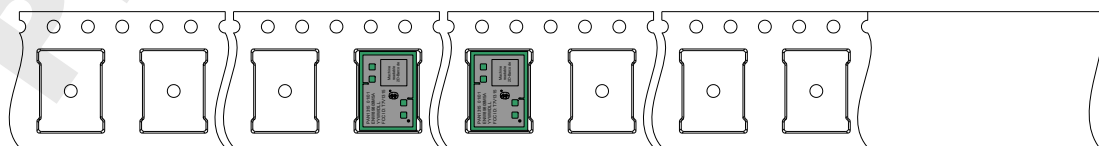

trailer (empty)  
1 x circumference /  
hub  
(min 160mm)

component  
packed area  
standard  
1500pcs

leader (empty)  
minimum 10 pitch

Top cover tape more  
than 1 x  
circumference plus  
100mm to avoid  
fixing of tape end on  
sealed modules.

Empty spaces in component packed area shall be less than two per reel and those spaces shall not be consecutive.

Top cover tape shall not be found on reel holes and shall not stick out from reel.

CLASSIFICATION Einstufung	PRODUCT SPECIFICATION Produktspezifikation	No. DS-1315-2400-102	REV. 0.98
SUBJECT Thema	CLASS 2 BLUETOOTH MODULE Bluetooth Modul der Klasse 2	PAGE Seite	28 of 32
CUSTOMER'S CODE PAN1315	PANASONIC'S CODE ENW89818C2JF	DATE Datum	21.04.2009

### 20.3. COMPONENT DIRECTION

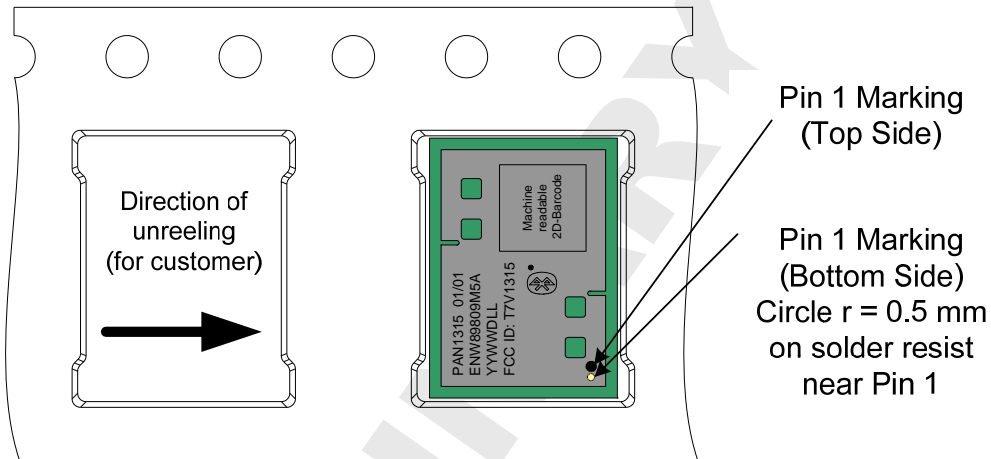

Please refer also to chapter 14. Labelling Drawing.

### 20.4. REEL DIMENSION

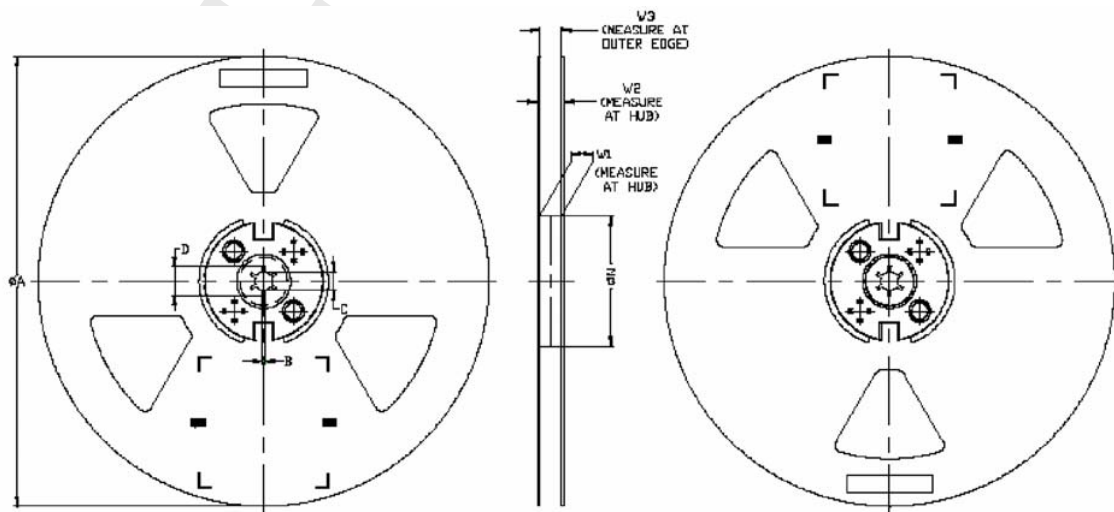

TAPE SIZE	A MAX	B MIN	C	D MIN	N ±1.0	W1	W2 MAX	W3	Assembly Method
24mm	330.0	1.5	13 <sup>+0.5</sup> <sub>-0.2</sub>	20.2	100.0	25.0 <sup>+2.0</sup> <sub>-0.0</sub>	30.4	24.4 <sup>+3.0</sup> <sub>-0.5</sub>	*Latch

All dimensions in millimeters unless otherwise stated

\*Latch (2PC)

CLASSIFICATION Einstufung	PRODUCT SPECIFICATION Produktspezifikation	No. DS-1315-2400-102	REV. 0.98
SUBJECT Thema	CLASS 2 BLUETOOTH MODULE Bluetooth Modul der Klasse 2	PAGE Seite	29 of 32
CUSTOMER'S CODE PAN1315	PANASONIC'S CODE ENW89818C2JF	DATE Datum	21.04.2009

## 20.5. LABEL FOR PACKAGE

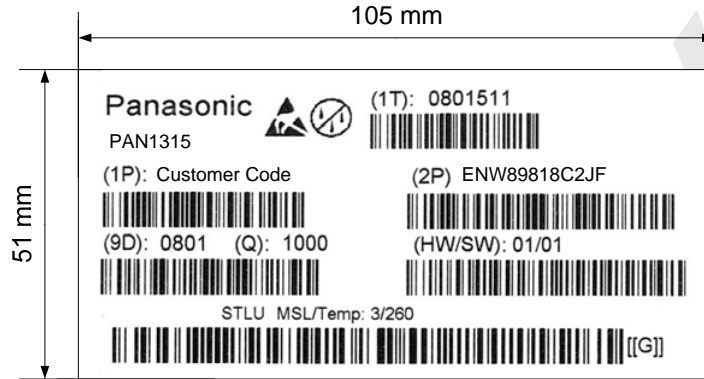

(1T)	Lotcode [YYWWDLL] YY year WW normal calendar week D day L line identifier, if more as one L lot identifier per day	Example from above: printed 08 printed 01 printed 5 (Friday) printed 1 printed 1
(1P)	Customer Order Code, if any, otherwise company name will be printed	
(2P)	Panasonic Order Code fix as ENW89818C2JF	
(9D)	Datecode as [YYWW]	
(Q)	Quantity [XXXX], variable max. 1500	
(HW/SW)	Hardware /Software Release	actual 01/01
	Hardware 01	first digit 1 is 70°C, second digit is Revision.
	Software 01	In case of EEPROM

## 20.6. TOTAL PACKAGE

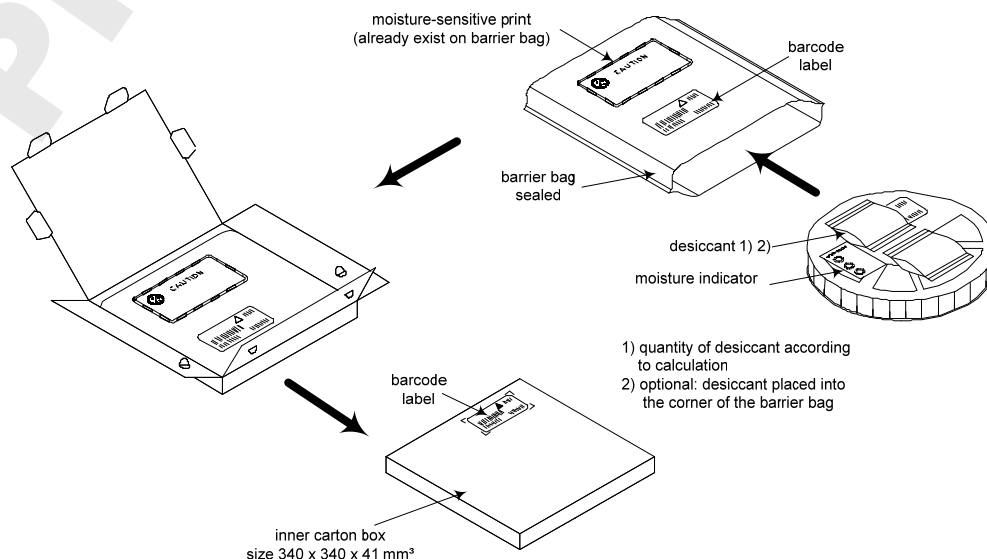

CLASSIFICATION Einstufung	PRODUCT SPECIFICATION Produktspezifikation	No. DS-1315-2400-102	REV. 0.98
SUBJECT Thema	CLASS 2 BLUETOOTH MODULE Bluetooth Modul der Klasse 2	PAGE Seite	30 of 32
CUSTOMER'S CODE PAN1315	PANASONIC'S CODE ENW89818C2JF	DATE Datum	21.04.2009

## 21. ORDERING INFORMATION

Ordering part number	Description	MOQ <sup>(1)</sup>
ENW89818C2JF <sup>(2)</sup>	PAN1315 CLASS 2 Bluetooth HCI Module (Standard 2.1), without EEPROM <sup>(4)</sup> , without ceramic antenna, 50 Ω bottom pad, operating temperature 70°C.	1500
ENW89818A2JF <sup>(3)</sup>	PAN1315 CLASS 2 Bluetooth HCI Module (Standard 2.1), without EEPROM <sup>(4)</sup> , with ceramic antenna, operating temperature 70°C.	1500

### Notes:

- (1) Abbreviation for Minimum Order Quantity (MOQ). The standard MOQ for mass production are 1500 pieces, fewer only on customer demand. Samples for evaluation can be delivered at any quantity.
- (2) Samples available
- (3) Samples will be available on customer demand
- (4) The version with EEPROM could be address up to +85°C, as the frequency offset could be stored in the EEPROM. As this is an HCI module, the host must be able to control these function.

## 22. ROHS DECLARATION

Declaration of environmental compatibility for supplied products:

Hereby we declare to our best present knowledge based on declaration of our suppliers that this product do not contain by now the following substances which are banned by Directive 2002/95/EC (RoHS) or if contain a maximum concentration of 0,1% by weight in homogeneous materials for

- Lead and lead compounds
- Mercury and mercury compounds
- Chromium (VI)
- PBB (polybrominated biphenyl) category
- PBDE (polybrominated biphenyl ether) category

And a maximum concentration of 0,01% by weight in homogeneous materials for

- Cadmium and cadmium compounds

## 23. DATA SHEET STATUS

This data sheet contains preliminary product specification. Panasonic reserves the right to change the specification without notice.

Preliminary product specification means also that the hardware has the engineering sample (ES) status.

Please consult the most recently issued data sheet before initiating or completing a design.

CLASSIFICATION Einstufung	PRODUCT SPECIFICATION Produktspezifikation	No. DS-1315-2400-102	REV. 0.98
SUBJECT Thema	CLASS 2 BLUETOOTH MODULE Bluetooth Modul der Klasse 2	PAGE Seite	31 of 32
CUSTOMER'S CODE PAN1315	PANASONIC'S CODE ENW89818C2JF	DATE Datum	21.04.2009

## 24. HISTORY FOR THIS DOCUMENT

Revision	Date	Modification / Remarks
0.90	18.12.2009	1 <sup>st</sup> preliminary version
0.95	01.03.2010	Updated chapter 10.8, 13 and 21.
0.96	Not released	Change ESD Information on foot note 1 (page 6) and 1 (page 7)
0.97	25.03.2010	Various updates. Deleted links to TI Datasheet.
0.98	21.04.2010	Updated Links Some minor changes in chapter 8 and 9.1 and change the base for the values in chapter 9.

## 25. RELATED DOCUMENTS

For an update, please search in the suitable homepage.

- [1] PAN1315ETU Schematic Rev 1.0, December 2009
- [2] IAR Embedded Workbench Version 3+ for MSP430 User's Guide Rev. Q, 25 Nov 2009, [Link](#) for the download:  
<http://www.ti.com/lit/pdf/slau138>

CLASSIFICATION Einstufung	PRODUCT SPECIFICATION Produktspezifikation	No. DS-1315-2400-102	REV. 0.98
SUBJECT Thema	CLASS 2 BLUETOOTH MODULE Bluetooth Modul der Klasse 2	PAGE Seite	32 of 32
CUSTOMER'S CODE PAN1315	PANASONIC'S CODE ENW89818C2JF	DATE Datum	21.04.2009

## 26. GENERAL INFORMATION

© Panasonic Electronic Devices Europe GmbH 2010.

All rights reserved.

This product description does not lodge the claim to be complete and free of mistakes.

Please contact the related product manager in every case.

If we deliver ES samples to the customer, these samples have the status Engineering Samples. This means, the design of this product is not yet concluded. Engineering Samples may be partially or fully functional, and there may be differences to be published Data Sheet.

Engineering Samples are not qualified and are not to be used for reliability testing or series production.

### **Disclaimer:**

Customer acknowledges that samples may deviate from the Data Sheet and may bear defects due to their status of development and the lack of qualification mentioned above.

Panasonic rejects any liability or product warranty for Engineering Samples. In particular, Panasonic disclaims liability for damages caused by

- the use of the Engineering Sample other than for Evaluation Purposes, particularly the installation or integration in an other product to be sold by Customer,
- deviation or lapse in function of Engineering Sample,
- improper use of Engineering Samples.

Panasonic disclaims any liability for consequential and incidental damages.

In case of any questions, please contact your local sales partner or the related product manager.

## 27. REGULATORY INFORMATION

### 27.1. FCC WARNING

This equipment is intended for use in a laboratory test environment only. It generates, uses, and can radiate radio frequency energy and has not been tested for compliance with the limits of computing devices pursuant to subpart J of part 15 of FCC rules, which are designed to provide reasonable protection against radio frequency interference. Operation of this equipment in other environments may cause interference with radio communications, in which case the user at his own expense will be required to take whatever measures may be required to correct this interference.

## 28. LIFE SUPPORT POLICY

This Panasonic product is not designed for use in life support appliances, devices, or systems where malfunction can reasonably be expected to result in a significant personal injury to the user, or as a critical component in any life support device or system whose failure to perform can be reasonably expected to cause the failure of the life support device or system, or to affect its safety or effectiveness. Panasonic customers using or selling these products for use in such applications do so at their own risk and agree to fully indemnify Panasonic for any damages resulting.