

Panasonic's new PAN1315 Host Controlled Interface (HCI) Bluetooth RF module brings Texas Instrument's seventh generation Bluetooth core integrated circuit, the CC2560, to an easy to use module format. Panasonic's tiny footprint technology has produced a module of only 58.5mm². The module is designed to accommodate PCBs pad pitch of 1.3mm and as little as two layers for easy implementation and manufacturing.

This module has been designed to be 100% pin compatible with the next generation of Bluetooth Low Energy devices. This unique design feature enables designers to seamlessly transition between Bluetooth Classic and Low Energy modules.

The PAN1315 makes connectivity between mobile devices such as cellular phones and small button cell battery powered devices like fitness sensors, watches, healthcare, entertainment and mobile accessories easily implemented, creating a seamless data chain from sensors to the web.

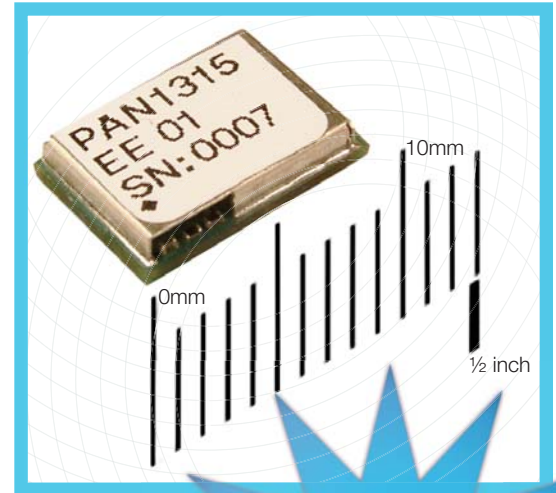

Product Performance:

- Best-in-class Bluetooth RF performance (Tx power, Rx sensitivity, blocking)
- Fully Qualified Bluetooth v2.1 EDR
- Dimensions: 6.5mm x 9mm x 1.7mm (width x length x height)
- Certifications: Bluetooth, FCC, CE, IC tested
- Operating Temperature Range: -20°C to +70°C
- Supply Voltage Range: 1.7 - 4.8V
- Profiles: SPP from TI, HDP from MindTree
- Based upon TI's CC2560
- Integrates with TI's ultra low-power MSP430 microprocessor
- Very fast algorithm for both ACL and eSCO
- Supports Extended Range Tx power with 10dBm typical output
- Low power scan method for page and inquiry scans at 1/3rd normal power

Interfaces:

The PAN1315 Host Controlled Interface supports several transport layers with the following features:

- UART Rates of up to 4Mbps
- Three and Four Wire UART Transport

Part Numbers:

Part Number	Description
ENW-89818C2JF	PAN1315, CC2560 HCI module, no antenna
ENW-89818C2KF	PAN1315, CC2560 HCI module, 256K EEPROM memory, no antenna
ENW-*****	PAN1315, CC2560 HCI module, antenna
ENW-*****	PAN1315, CC2560 HCI module, 256K EEPROM memory, antenna
PAN1315ETU	PAN1315, Development module, for use with EVAL_PAN1315 evaluation kit
EVAL_PAN1315	PAN1315 Evaluation kit, includes TI MSP430 controller

Applications:

- Consumer Health Devices
 - Heart Rate Monitor
 - Blood Pressure Sensor
 - Blood Glucose Meter
 - Thermometer
- Assisted Living
 - Flood Alarm
 - Heating Control
 - Automatic Key Control
- Industrial Sensors

Block Diagram:

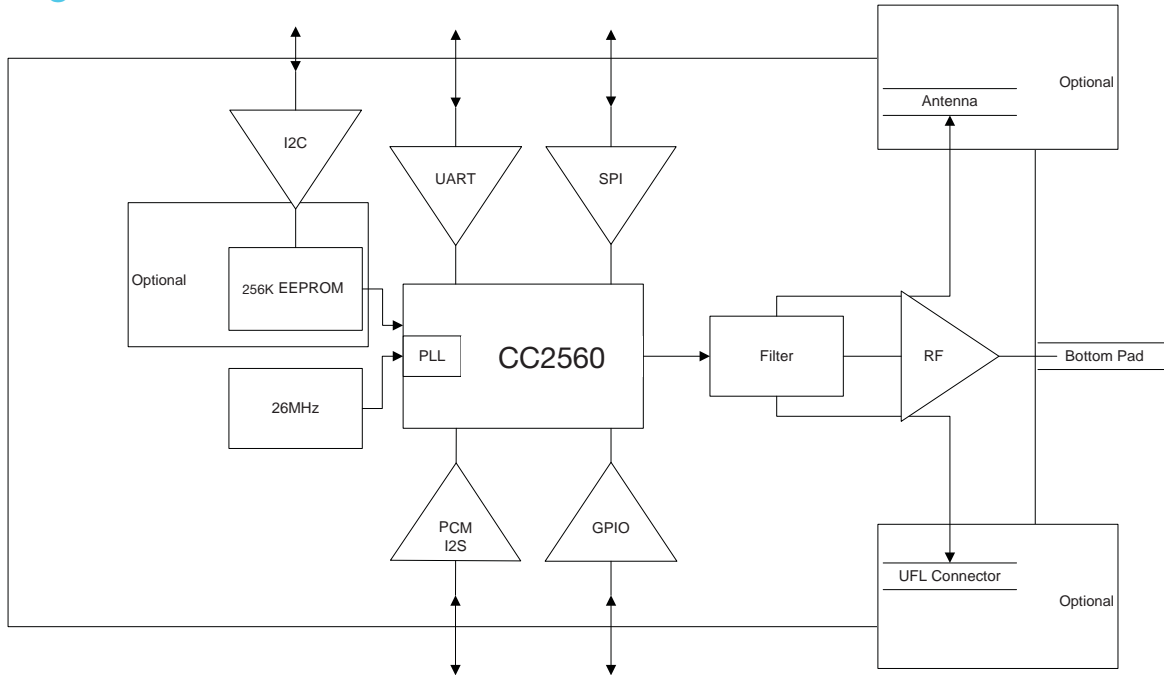

Technical Specifications:

Parameter	Value	Condition / Notes
Receiver Sensitivity (BER=10 ⁻³)	-93 dBm	GFSK, Typical, Dirty TX On
Output Power	10 dBm	VDD_In = V _{BAT}
Power Supply	1.7 - 4.8 V	Battery or DC/DC
Ultra Low Power Scan	135 μA	1.28s Interval
GFSK DH1\DH5	33 mA	Full Throughput
Operating Temperature Range	-20°C to + 70°C	-40°C to + 85°C with EEPROM