PKE System Design Using the PIC16F639

*Author: Youbok Lee, Ph.D.
Microchip Technology Inc.*

INTRODUCTION

Hands-free Passive Keyless Entry (PKE) is quickly becoming mainstream in automotive remote keyless entry applications and is a common option on new automobile models. Instead of pressing a transmitter button to unlock or lock a car door, it is possible to gain vehicle access simply having a valid transponder in your possession.

Hands-free PKE applications require bidirectional communication between the base station and transponder units. The base unit inside the vehicle transmits a Low-Frequency (LF) command that searches for a transponder in the field. Once located, the transponder in the vehicle owner's possession then automatically responds to the base unit. The base unit then unlocks the car doors, if a valid authentication response is received.

In typical PKE applications, the base station unit is designed to output the maximum power that is allowed by electromagnetic field radiation rules that are mandated by government agencies. When it operates with a 9 to 12 VDC of power source, the maximum attainable antenna voltage is about 300 V_{PP}. Because of the non-propagating property of the low-frequency (125 kHz) signal, the signal level becomes only about a few mV_{PP} when it is received by a typical key fob transponder approximately two meters away from the

base station unit. Furthermore, due to antenna orientation properties, the input signal level at the transponder becomes considerably weaker if the antenna is not oriented face-to-face with the base station antenna.

The most probable source of PKE operation failure is due to a weak input signal level at the transponder. Therefore, for a reliable hands-free PKE application, it is necessary to make the input signal strong enough (above input sensitivity level) in any condition within the desired communication range.

In order to make the PKE system reliable, the system designer must consider four important parameters:

1. Output power of the base station command,
2. Input sensitivity of the transponder,
3. Antenna directionality, and
4. Battery life of the transponder.

The PIC16F639 is a microcontroller (MCU) with a three-channel analog front-end. The device's analog front-end features are controlled by the MCU firmware. Because of its easy-to-use features, the device can be used for various smart low-frequency sensing and bidirectional communication applications.

This application note provides design circuit examples of the smart PKE transponder using the PIC16F639 MCU. The MCU firmware examples for the circuits shown in this application note are also available. The given circuit and MCU firmware examples can be easily modified for users specific applications.

PIC16F639 PKE TRANSPONDER

The PIC16F639 has a digital MCU section (PIC16F639 core) and an analog front-end (AFE) section. The device can be used for various low-frequency sensing and bidirectional smart communication applications.

Figure 1 shows an example of a typical PKE system. The base station unit transmits a 125 kHz command to search for a valid transponder in the field. The PKE transponder sends back a response if the received command is valid.

The PIC16F639 device has high analog input sensitivity (up to 1 mVPP) and three antenna connection pins. By connecting three antennas that are positioned to x, y and z directions, the transponder can pick up signals from any direction at any given time. Therefore, it reduces the likelihood of missing signals due to the properties of antenna directionality. The input signal at each antenna pin is detected independently and summed afterwards. Each input channel can be independently enabled or disabled by programming the Configuration register. The device consumes less operating power if fewer channels are enabled.

For hands-free operation, the transponder is continuously waiting and detecting input signals. This presents an issue for the life expectancy of the battery. Therefore, in order to reduce the operating current, the digital MCU section can stay in low-current mode (Sleep), while the Analog Front-End (AFE) is looking for a valid input signal. The digital MCU section is waking up only when the AFE detects a valid input signal. This feature is possible by using an Output Enable Filter (wake-up filter). There are nine Output Enable Filter options available in the PIC16F639. Users can program the filter using the Configuration register. Once the filter is programmed, the device passes detected output to the digital section only if the incoming signal meets the filter requirement.

Figure 2 shows an example of the PKE transponder configuration. The transponder consists of the PIC16F639 device, external LC resonant circuits, push buttons, a UHF transmitter, battery back-up (optional), and a 3V lithium battery.

The digital sections have two I/O ports; PORTA and PORTC. Each of the PORTA pins is individually configurable as an Interrupt-on-change pin. The pins on PORTC have no Interrupt-on-change function.

The AFE section shares three I/O pins in PORTC of the digital section; RC1, RC2 and RC3, which are internally bonded with \overline{CS} , SCLK/ALERT and LFDATA/CCLK/RSSI/SDIO pad of the AFE, respectively. LFDATA/CCLK/RSSI and ALERT are outputs of the AFE. SDIO, SCLK and \overline{CS} are used to program or read the AFE Configuration registers. Refer to the PIC12F635/PIC16F636/639 Device Data Sheet (DS41232) for more details (see “References”).

To save battery power, the digital section is normally in Sleep mode while the AFE section is detecting LF input signals. Although the AFE's output pads are internally bonded to the PORTC pins, the AFE output cannot wake-up the digital section from Sleep by Interrupt-on-change events, because the pins are not Interrupt-on-change pins. Therefore, it is recommended that the LFDATA and ALERT pins of the AFE be connected to the PORTA pins externally, as shown in Figure 2.

The digital section can wake up when one of the following three conditions occur:

1. AFE output at LFDATA pin,
2. AFE output at ALERT pin, or
3. Any event by push button switches on PORTA.

FIGURE 1: BIDIRECTIONAL PASSIVE KEYLESS ENTRY (PKE) SYSTEM

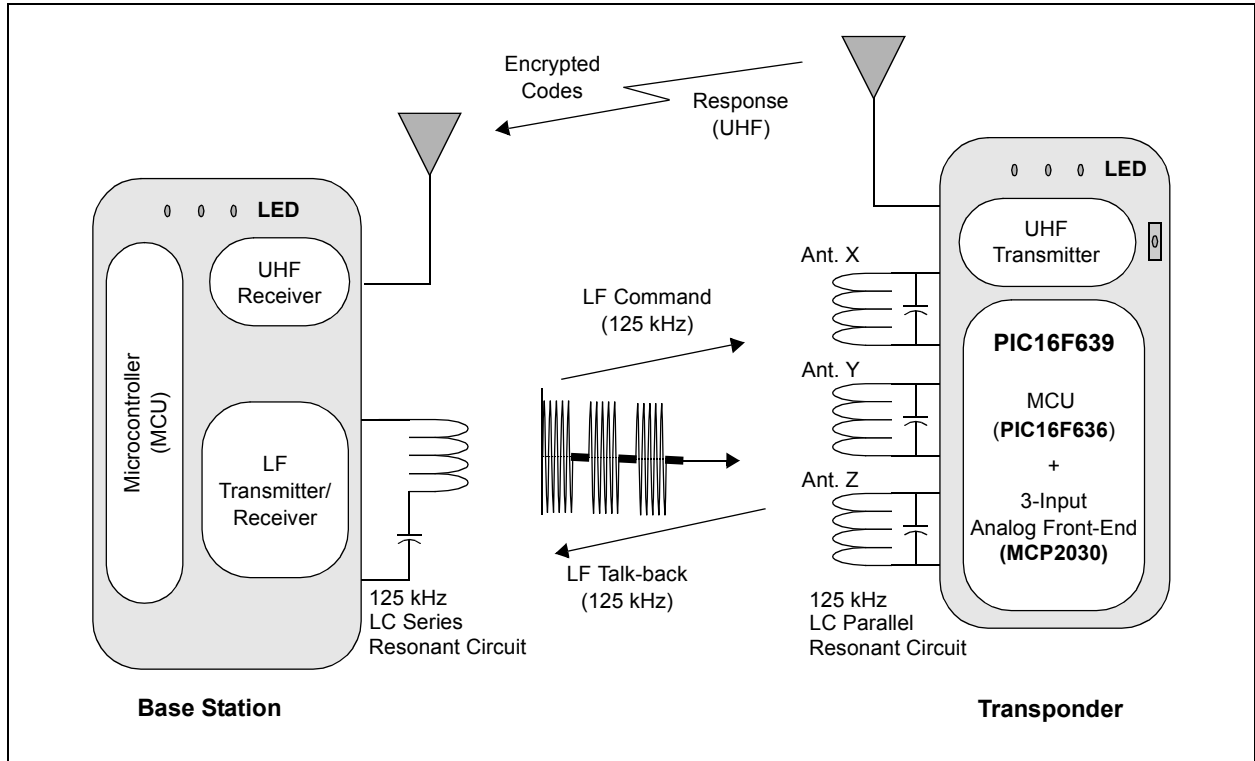
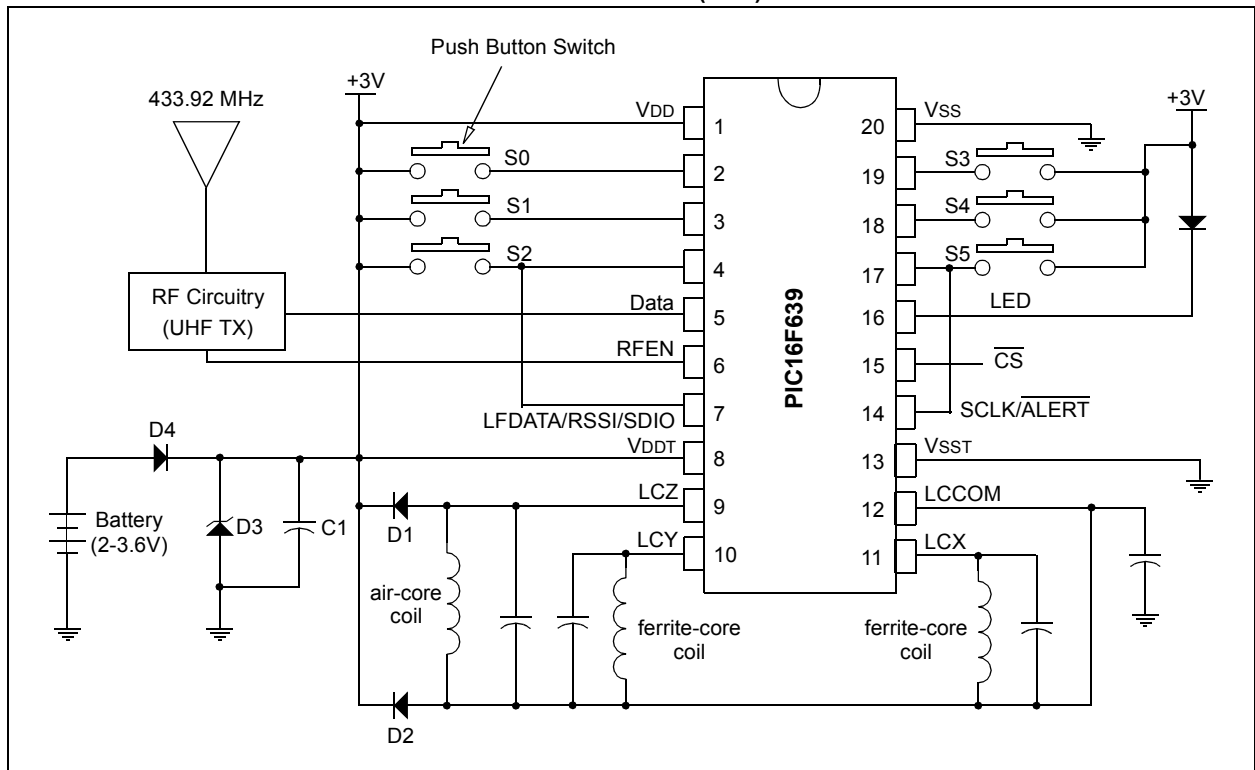

FIGURE 2: EXAMPLE OF PASSIVE KEYLESS ENTRY (PKE) TRANSPONDER CONFIGURATION



AN1024

Wake-up Filter and Signal Detection

Users can program one of the nine possible Output Enable filters using the Configuration registers. Refer to the PIC12F635/PIC16F636/639 Device Data Sheet (DS41232) for more details (see “References”).

Figures 3 and 4 show examples of inputs and demodulated outputs. The input signal is applied to one of the three input pins or on all pins (LCX, LCY, LCZ) at the same time. The outputs are available on the LFDATA pin of the device. The figures show the differences in output pins depending on the setting of the output enable (wake-up) filter option. For the cases shown in Figure 3 and Figure 4, the minimum

modulation depth requirement is set to 8% and the Output Enable Filter is set to (TOEH: 2 ms, TOEL = 2 ms). The input signal amplitude is 2.7 mVPP with a modulation depth of about 9%. Figure 3 shows the input signal and the demodulated data output after the wake-up filter is matched. The demodulated output of the correct (wanted) input signal wakes up the digital section, and will respond if the command is valid. Figure 4 shows the case when the input does not meet the programmed filter requirement. The demodulated output is not available at the output pin since the input does not meet the programmed filter requirement. This ensures that the digital section will not wake-up due to unwanted input signals.

FIGURE 3: INPUT SIGNAL AND DEMODULATED OUTPUT WHEN OUTPUT ENABLE FILTER IS ENABLED AND INPUT MEETS THE FILTER TIMING REQUIREMENT

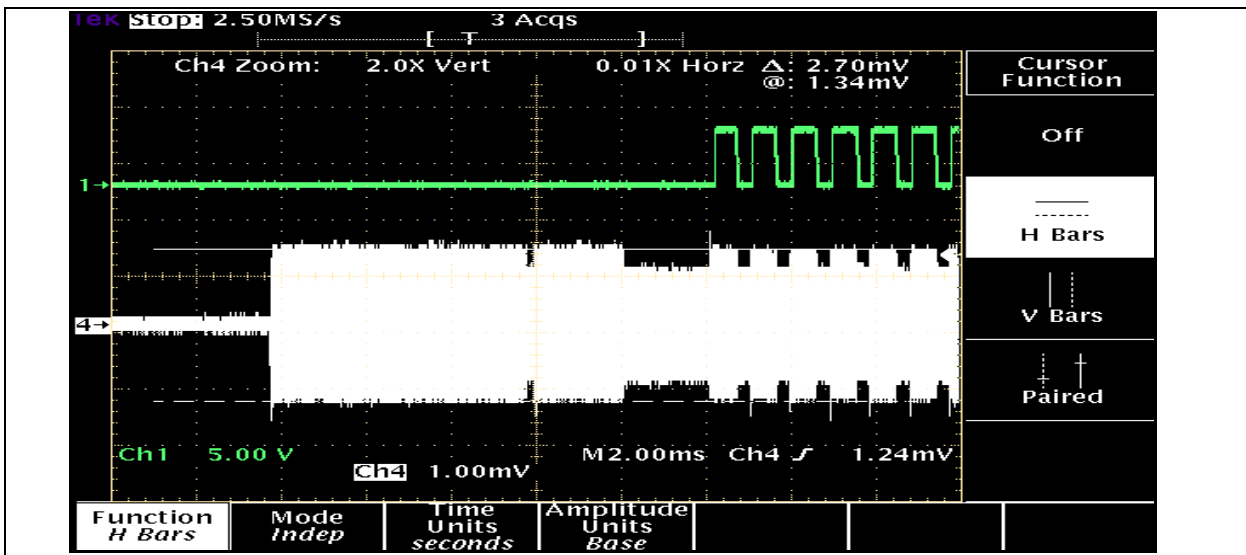
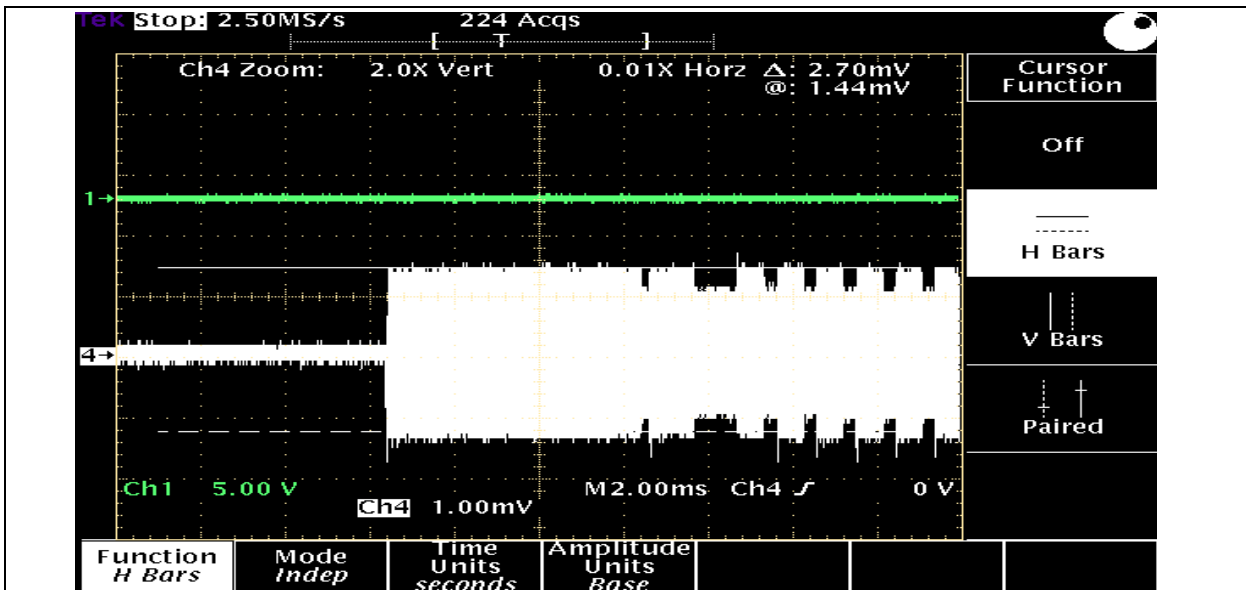

FIGURE 4: INPUT SIGNAL AND DEMODULATED OUTPUT WHEN OUTPUT ENABLE FILTER IS ENABLED AND INPUT DOES NOT MEET THE FILTER TIMING REQUIREMENT



External LC Resonant Antenna

The PIC16F639 device includes three low-frequency input channels. The LCX, LCY and LCZ pins are for external LC resonant antenna circuit connections (for each LF input channel). The external circuits are connected to the antenna input pins and the LCCOM pin. LCCOM is a common pin for all external antenna circuits. A capacitor (1-10 μ F) between the LCCOM pin and ground is recommended to provide a stable condition for the internal detection circuit when it detects strong input signals.

Although the PIC16F639 has three LC input pins for the three external antenna attachments, the user can use only one or two antennas, instead of using all three, depending on the application. The operating current consumption is proportional to the number of channels enabled. Fewer channels enabled results in lower current consumption. However, it is highly recommended to use all three antennas for hands-free PKE applications.

THEORY OF LC RESONANT ANTENNA

To detect a low-frequency magnetic field, a tuned loop antenna is commonly used. In order to maximize the antenna voltage, the loop antenna must be precisely tuned to the frequency of interest. For PKE applications, the antenna should be tuned to the carrier frequency of the base station. The loop antenna is made of a coil (inductor) and capacitors that are forming a parallel LC resonant circuit. The voltage across the antenna is also maximized by increasing the surface area of the loop and quality factor (Q) of the circuit.

The resonant frequency of the LC resonant circuit is given by Equation 1:

EQUATION 1:

$$f_o = \frac{1}{2\pi\sqrt{LC}}$$

where L is the inductance of the loop and C is the capacitance.

For a given LC resonant circuit, the received antenna voltage is approximately given by Equation 2 (refer to application note AN710, "Antenna Circuit Design for RFID Applications," (DS00710) for details):

EQUATION 2:

$$V_{coil} \approx \frac{f_c}{(1 + \Delta f)} NSQB_o \cos \alpha$$

where:

f_c = Carrier frequency of the base station (Hz)

Δf = $|f_c - f_o|$

f_o = Resonant frequency of LC circuit (Hz)

N = Number of turns of coil in the loop

S = Surface area of loop in square meters

Q = Quality factor of LC circuit

B_o = Magnetic field strength (Weber/m²)

α = Angle of arrival of signal

In Equation 2, the quality factor (Q) is a measure of the selectivity of the frequency of the interest by the tuned circuit. Assuming that the capacitor is lossless at 125 kHz, Q of the LC circuit is mostly governed by the inductor defined by:

EQUATION 3:

$$Q_L = \frac{2\pi f_o L}{r}$$

where f_o is the tuned frequency, L is the inductance value and r is the resistance value of the inductor.

In typical transponder applications, the inductance value is in the 1-9 mH range. Q of the LC circuit is greater than 20 for an air-core inductor and about 40 for a ferrite-core inductor.

The $S \cos \alpha$ term in Equation 2 represents an effective surface area of the antenna that is defined as an exposed area of the loop to the incoming magnetic field. The effective antenna surface area is maximized when $\cos \alpha$ becomes unity, which occurs when the antennas of the base station and the transponder units are positioned in a face-to-face arrangement. In practical applications, the user might notice the longest detection range when the two antennas are facing each other and the shortest range when they are orthogonally faced. Figure 5 shows a graphical demonstration of the antenna orientation problem in practical applications.

AN1024

FIGURE 5: ANTENNA ORIENTATION DEPENDENCY

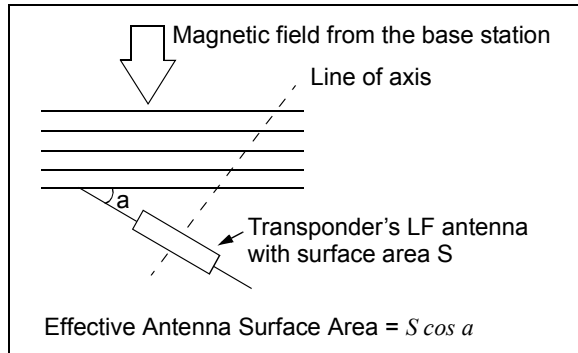

The antenna orientation problem can be significantly reduced if the three antennas are placed orthogonally on the same PCB board. This increases the probability that at least one of the transponder antennas faces toward the base station antenna at a given incident during application. Figure 6 shows a graphical illustration of placing three antennas on the transponder board. A large air-core coil is used for LCZ and two ferrite-core coils are used for LCX and LCY. There are companies that make the ferrite coils specifically for the 125 kHz RFID and low-frequency sensing applications.

FIGURE 6: RECOMMENDED ANTENNA PLACEMENT ON TRANSPONDER BOARD

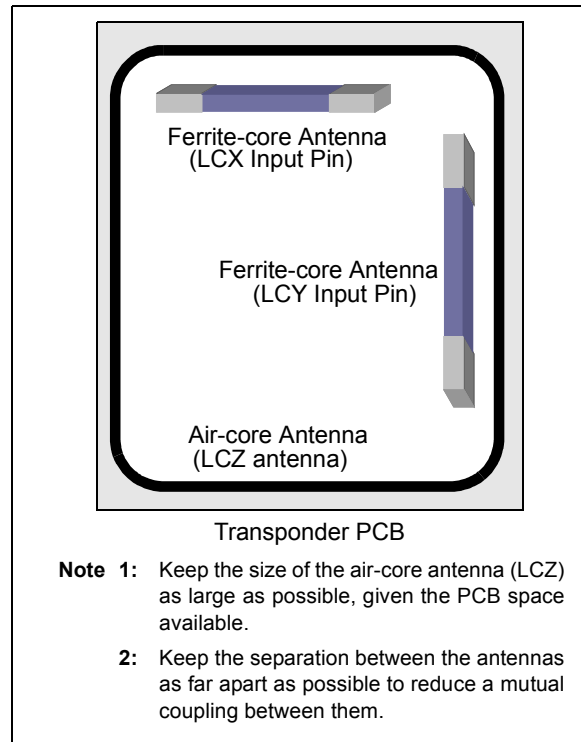

LC ANTENNA TUNING

As shown in Equations 2 and 3, the induced coil voltage is maximized when the LC circuit is tuned precisely to the incoming carrier frequency. In practical applications, however, the LC resonant frequency differs from transponder to transponder due to the tolerance variation of the LC components. To compensate the error due to the component tolerance, the PIC16F639 has an internal resonant capacitor bank per channel. The capacitor value can be programmed up to 63 pF with 1 pF per step. Figure 7 shows an example of the capacitance tuning using the Configuration register bits (6 bits). The capacitance is monotonically increased with the Configuration register bits. Refer to the PIC12F635/PIC16F636/639 Device Data Sheet (DS41232) for more details (see “References”).

The capacitance can be effectively tuned by monitoring the RSSI current output. The RSSI output is proportional to the input signal strength. Therefore, the higher RSSI output will be monitored the closer the LC circuit is tuned to the carrier frequency.

The total capacitance adds up as the Configuration register bits step up. The resulting internal capacitance is added to the present capacitor values of the LC circuit. The LC resonant frequency will shift to lower by adding the internal resonant capacitor.

FIGURE 7: CAPACITANCE TUNING VS. BIT SETTING

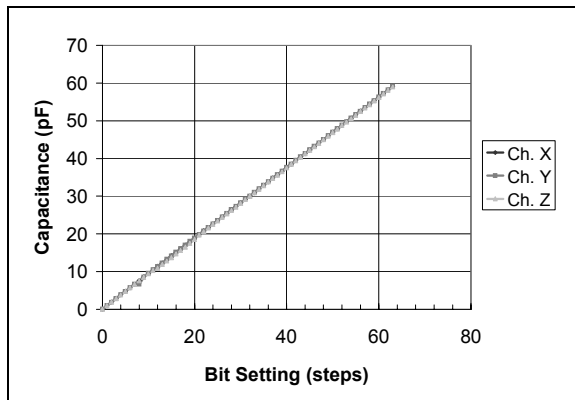

Battery Back-up and Batteryless Modes

In real-life applications, there is the chance that the battery can be momentarily disconnected from the circuit by accident, for example, if the unit is dropped onto a hard surface. If this should happen, the data stored in the MCU may not be recovered correctly. To protect the battery from accidental misplacement, users may consider using a battery back-up circuit. The battery back-up circuit provides a temporary VDD voltage to the transponder. The circuit is recommended for sophisticated transponders, but may not be a necessary mechanism for all applications. In Figure 2, D4 and C1 form the battery back-up circuit. C1 is fully charged when the battery is connected and provides the VDD when the battery is momentarily disconnected.

The Batteryless mode is the case when the transponder is operating without the battery. In Figure 2, diodes D1, D2, D3 and C1 form a power-up circuit for batteryless operation. When the transponder coil develops voltages, the coil current flows through the diodes, D1 and D2, and charges the capacitor, C1, which can provide the VDD for the transponder. The power-up circuit is useful when the PIC16F639 is used for anti-collision transponder applications, where batteryless operation is preferred. The value of the capacitor, C1, for Batteryless mode is from a few μF to a few Farad (F) depending on the application.

LOW-FREQUENCY SIGNAL DETECTION ALGORITHM AND DETECTOR OUTPUT

Figure 8 shows the flow chart of the input signal detection with the wake-up filter enabled.

The MCU firmware, *PIC16F639_Basestation.asm*, is available for download from Microchip's web site, www.microchip.com (see **Appendix A: "Source Code"**).

Examples of the schematics for the PKE transponder and the base station are shown in **Appendix B: "Transponder"**, Figure B-1, Figure C-1 and Figure C-2 respectively. These schematics were developed for customer training purposes of the PIC16F639 transponder. Users can use the circuits as references when they develop their own systems. Users can also refer to the PKE reference demonstration kit (P/N: APGRD001), which is available from Microchip.

FIGURE 8: PIC16F639 SIGNAL DETECTION FLOW CHART

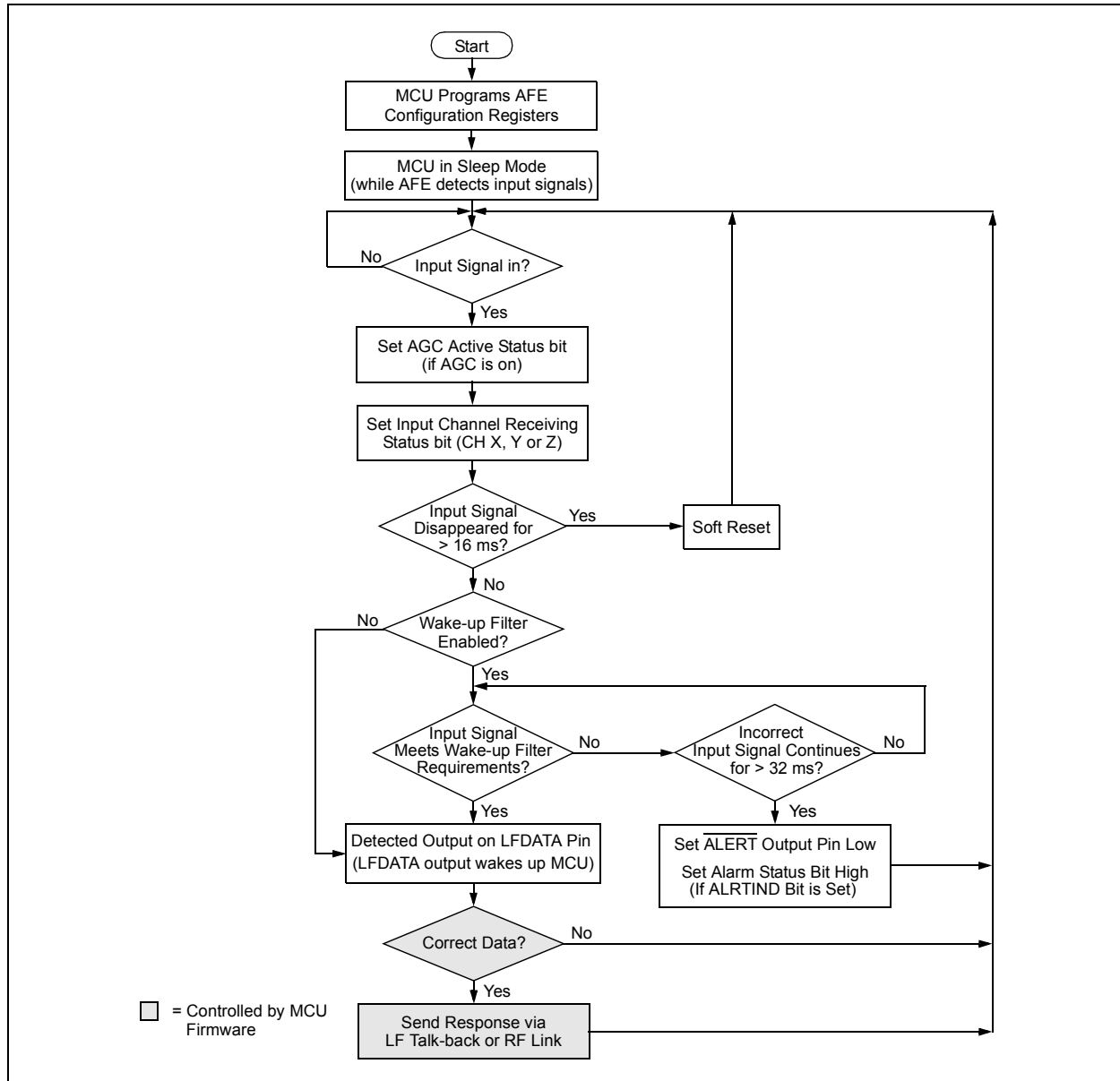

TRANSPONDER CIRCUIT

Figure B-1, in **Appendix B: “Transponder”**, shows an example of the PKE transponder circuit which has been used for customer training and device demonstration purposes.

The transponder circuit has three external LC resonant circuits, 5 push button switches, a 433.92 MHz resonator for UHF data transmission and components for Battery Back-up mode.

Each LC resonant circuit is connected to the LC input and LCCOM pins. The air coil antenna is connected to the LCX input and the two ferrite-rod inductors are connected to the LCY and LCZ pins. The LCCOM pin is a common pin for all three antenna connections, which is grounded via C11 and R9. Each resonant antenna must be tuned to the carrier frequency of the base station unit for the best signal reception conditions. The internal capacitor of each channel can be used to tune the antenna for the best performance.

When the device is powered up initially, the digital section programs the Configuration registers of the AFE using the SPI (CS, SCLK/ALERT, SDIO).

The AFE is very sensitive to environmental noise due to its high input sensitivity (~3 mV_{PP}); therefore, take appropriate care to prevent excess AC noise along the PCB traces. Capacitors C6 and C12 are used for noise filtering for the V_{DD} and V_{DDT} pins, respectively.

Diodes D1 and D2, and capacitor C5 are for the Battery Back-up mode. Diodes D2, D3 and D7 and capacitor C5 are for Batteryless mode. A larger C5 value is needed for stable Batteryless mode operation. Capacitor C5 holds the charges from the battery and from the coil voltage through diodes D3 and D7. The stored charge on C5 can keep the PIC16F639 device powered when the battery is momentarily disconnected. Diodes D3 and D7 are connected across the air coil, which develops the strongest coil voltage among the three external LC resonant antennas.

Once a valid input signal is detected, the digital MCU section is waken up and transmits a response if the command is valid.

The transponder can send responses using an internal modulator (LF talk-back) or an external UHF transmitter. The analog input channel has an internal modulator (transistor) per channel between the input and the LCCOM pins. The internal modulator is turned on and off if the AFE receives Clamp-On and Clamp-Off commands from the digital MCU section, respectively. The antenna voltage is clamped or unclamped depending upon the Clamp-On or Clamp-Off command, respectively. This is called LF talk-back, which is used for proximity range applications only. The base station can detect the changes in the transponder antenna voltage and reconstruct the modulation data.

See the PIC12F635/PIC16F636/639 Device Data Sheet (DS41232) for more details of the LF talk-back (see “References”).

The transponder uses a UHF transmitter for long range applications. An On-Off-Keying UHF transmitter is formed by the UHF (433.92 MHz) resonator U2 and power amplifier Q1. The values of capacitors C2 and C3 are approximately 20 pF range each, but are layout dependent. The L1, which is typically formed by a metal trace on the PCB, is a UHF antenna and its efficiency increases significantly by increasing its loop area.

The UHF transmitter section is turned on when the MCU I/O pin outputs a logic level high; otherwise it is turned off. The output of RC5 is the modulation data of the UHF signal and can be reconstructed by the UHF receiver in the base station.

AN1024

BASE STATION CIRCUIT

Figure C-1 and Figure C-2, in **Appendix C: “Base Station”**, show an example circuit of the base station, which has been used for customer training and device demonstration purposes.

The base station unit consists of a microcontroller, 125 kHz transmitter/receiver and an UHF receiver module.

The base station transmits a 125 kHz low-frequency command and receives responses from the transponders in the field via UHF or LF talk-back. After transmitting the LF commands, it checks whether there is any response through LF or UHF link.

The 125 kHz transmitter generates a carrier signal based on the MCU's Pulse-Width Modulator (PWM) output. The power of the 125 kHz square pulses from the MCU is boosted by the current driver, U1. The square pulse output from U1 becomes sine waves as it passes through an LC series resonant circuit that is formed by L1, C2, C3 and C4. L1 is an air-core inductor and is used for the 125 kHz LF antenna.

The antenna radiation becomes maximized when the LC series resonant circuit is tuned to the frequency of the PWM signal. At the resonant frequency, the impedance of the LC circuit is minimized. This results in a maximum load current through L1 and therefore produces strong magnetic fields. Users may tune the LC circuit by monitoring the coil voltage across L1.

The components after diode D1 are used to receive the LF talk-back signal from the transponder. When the transponder responds with LF talk-back, there will be changes in the coil voltage (across L1) due to the magnetic fields originated by the voltage on the transponder coil. Since the voltage on the transponder coil is initially caused by the voltage of the base station antenna (L1), the return voltage has 180° phase difference with respect to the originating voltage. Therefore, at a given condition, the voltage across L1 changes with the coil voltage of the transponder coil.

The change in the coil voltage (across L1) can be detected through an envelope detector and low-pass filter formed by D1 and C5. The detected envelope passes through active gain filters, U2A and U2B. The demodulated analog output is fed into the comparator input pin of the MCU for pulse shaping. The output of the comparator is available on TP6 and decoded by the MCU.

U4 is the 433.92 MHz ASK receiver module. This receiver module detects the transponder's UHF responses. The digital output from this module is fed into the MCU for decoding. An antenna (a few inches long) is typically attached to the antenna pad of the module to receive a signal in stable condition. Since the receiver module is next to the LF transmitter section, which produces strong fields, the module typically outputs noise. Therefore, it may require an adequate firmware routine to filter out the noise inputs.

The base station unit displays the data on the LCD or turns on the buzzer each time valid data is received.

FIRMWARE EXAMPLES

Firmware examples, including HTML documentation for the transponder and the base station units are available in an archived file (see **Appendix A: “Source Code”**).

The main firmware files for the transponder and the base station are *PIC16F639_Transponder.asm* and *PIC16F639_BaseStation.asm*, respectively.

The firmware does not use the KEELOQ® security IC algorithm. Contact Microchip sales for assistance if you want to use KEELOQ security ICs in your design.

Figure 9 shows an example of the handshake between the base station and the transponder.

Figure 10 shows a communication example between the transponder and base station units by using the firmware.

FIGURE 9: EXAMPLE OF HANDSHAKE BETWEEN BASE STATION AND TRANSPONDER

Base Station Transmits: (Step 1)	AGC Stabilization Pulse + Wake-up Filter + 10 bits (ID Command + Parity + Stop Bit)
Transponder Transmits: (Step 2)	Header + ID (32 bits) + 4 Parity bits
Base Station Transmits: (Step 3)	AGC Stabilization Pulse + Wake-up Filter + IFF Command (8 bits) + Challenge (32 bits) + 5 Parity bits + Stop Bit (46 bits)
Transponder Transmits: (Step 4)	Header + Response (32 bits) + 4 Parity bits (36 bits)
Base Station:	Display message on LCD

FIGURE 10: COMMUNICATION LINK BETWEEN BASE STATION AND TRANSPONDER

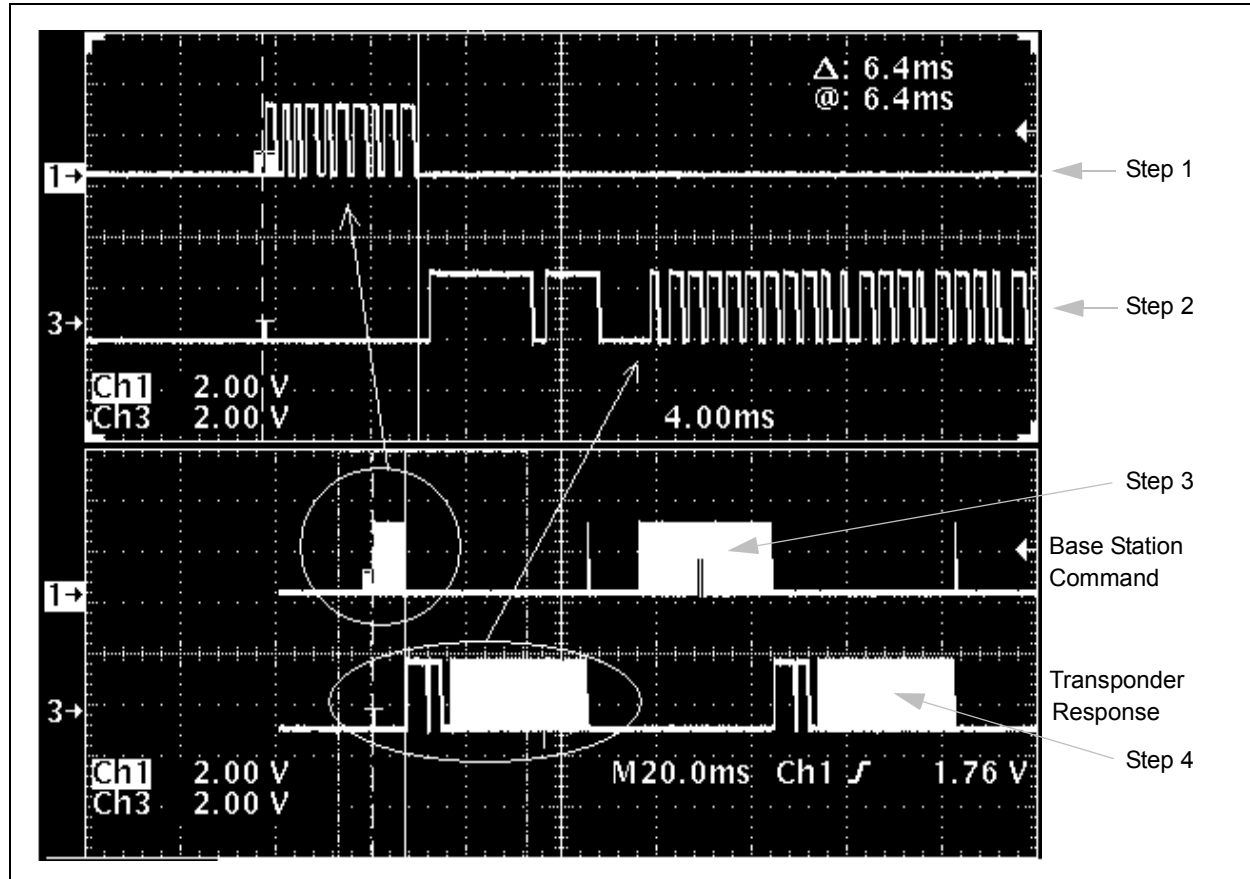

CONCLUSION

The PIC16F639 device is an easy-to-use, low cost and secure bidirectional communication transponder. This device can be used for various smart hands-free passive keyless entry applications. A basic configuration of the Passive Keyless Entry (PKE) transponder is shown in Figure 2. Example schematics for the transponder and the base station are shown in **Appendix B: "Transponder"** and **Appendix C: "Base Station"**.

The firmware examples for the transponder and the base station are also provided (see **Appendix A: "Source Code"**). Users can modify the provided examples for their application purposes.

MEMORY USAGE

Transponder:

- Program Memory – 1131 words
- Data Memory – 65 Bytes

Base Station:

- Program Memory – 1178 words
- Data Memory – 405 Bytes

REFERENCES

- "PIC12F635/PIC16F636/639 Data Sheet," DS41232, Microchip Technology Inc.
- AN710, "Antenna Circuit Design for RFID Applications," Application Note (DS00710), Microchip Technology Inc.
- AN959, "Using the PIC16F639 MCU for Smart Wireless Applications," Application Note (DS00950), Microchip Technology Inc.
- TB088, "PIC16F639 Microcontroller Overview," Technical Brief (DS91088) Microchip Technology Inc.
- TB090, "MCP2030 Three - Channel Analog Front-End Device Overview," Technical Brief (DS91090A) Microchip Technology Inc.
- "MCP2030 Data Sheet", (DS21981), Microchip Technology Inc.
- "Coilcraft Data Sheet", (P/N 4308 and 5315 Series); <http://www.coilcraft.com>

APPENDIX A: SOURCE CODE

The complete source code, including any firmware applications and necessary support files, is available for download as a single archive file from the Microchip corporate web site, at:

www.microchip.com

FIGURE B-3: BOTTOM MASK VIEW OF TRANSPONDER

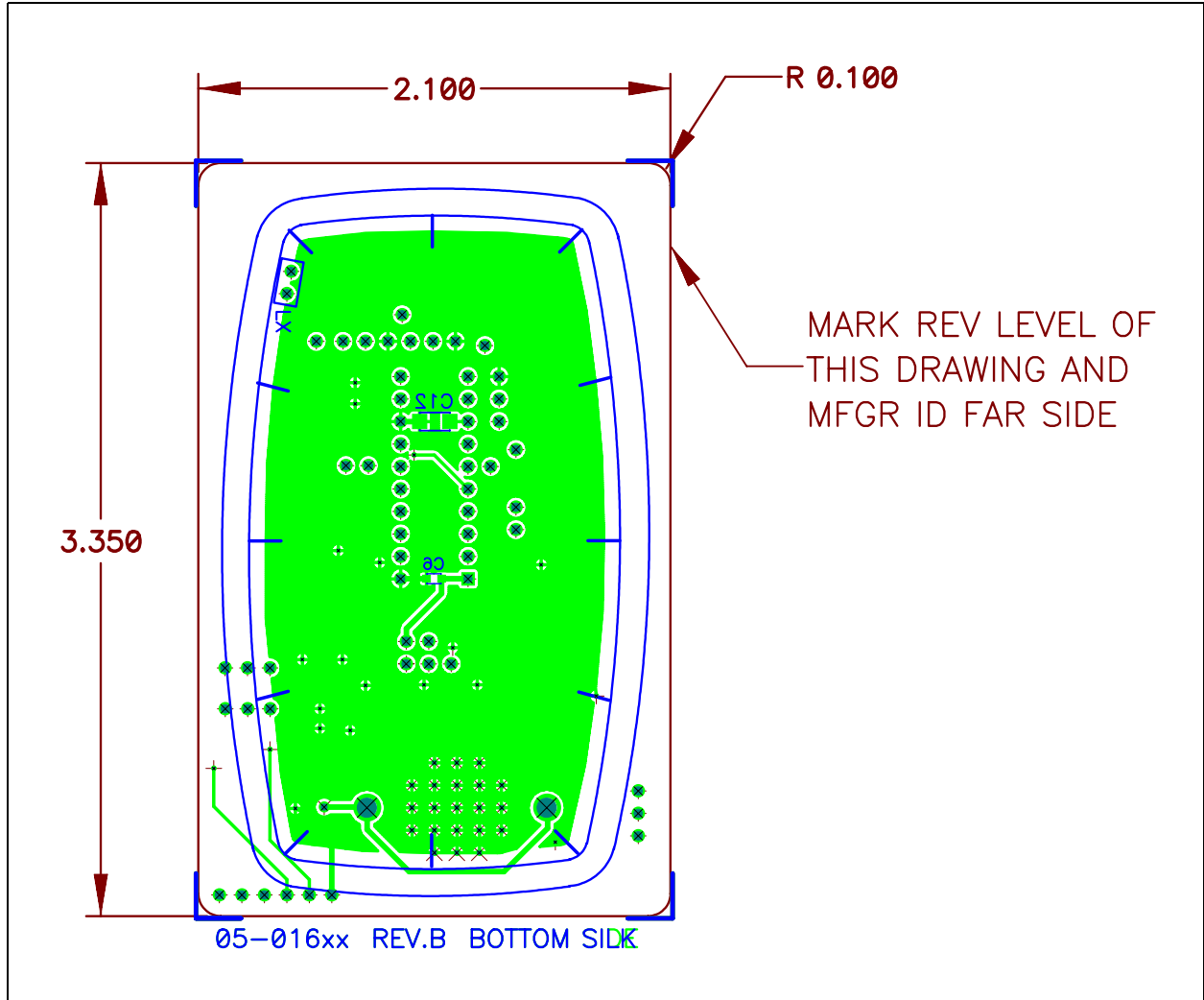
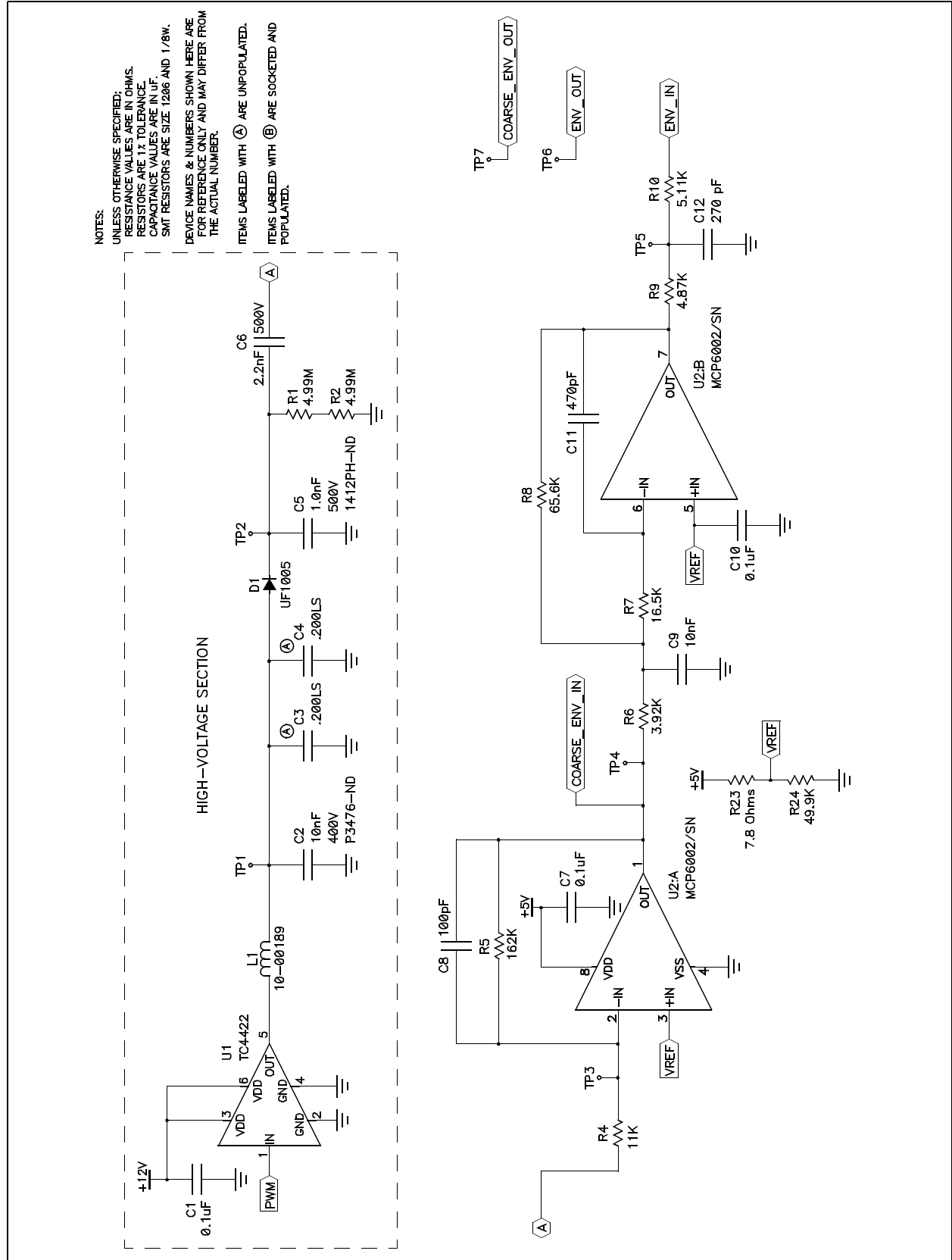

FIGURE C-2: BASE STATION SCHEMATIC SHEET 2 OF 2



AN1024

FIGURE C-3: TOP MASK VIEW OF BASE STATION

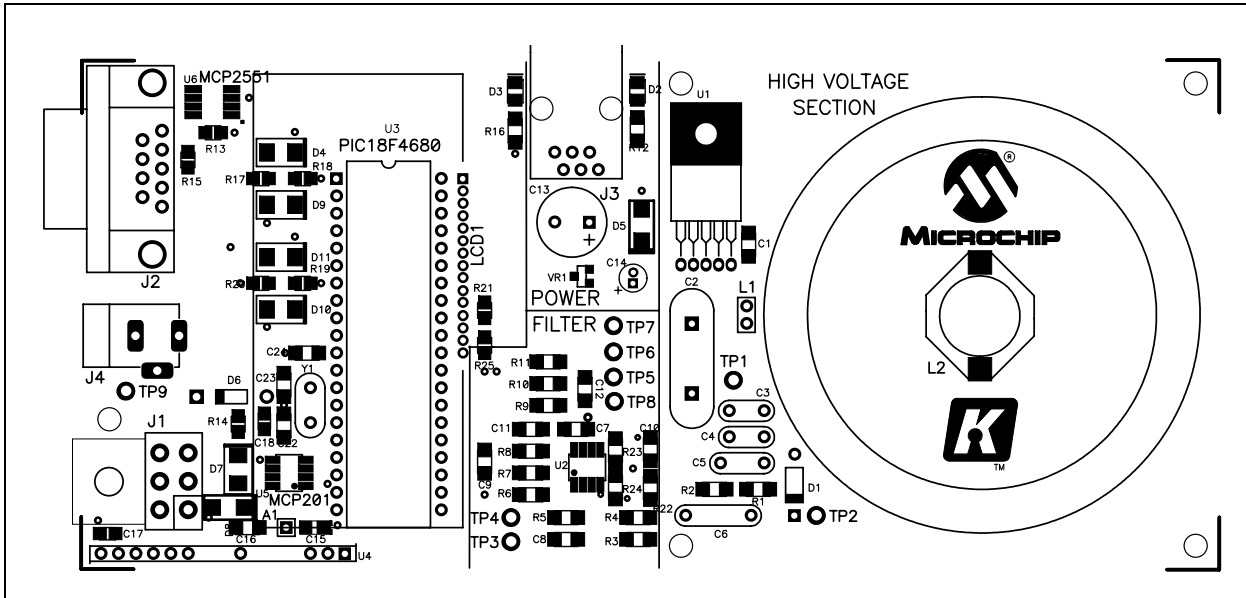
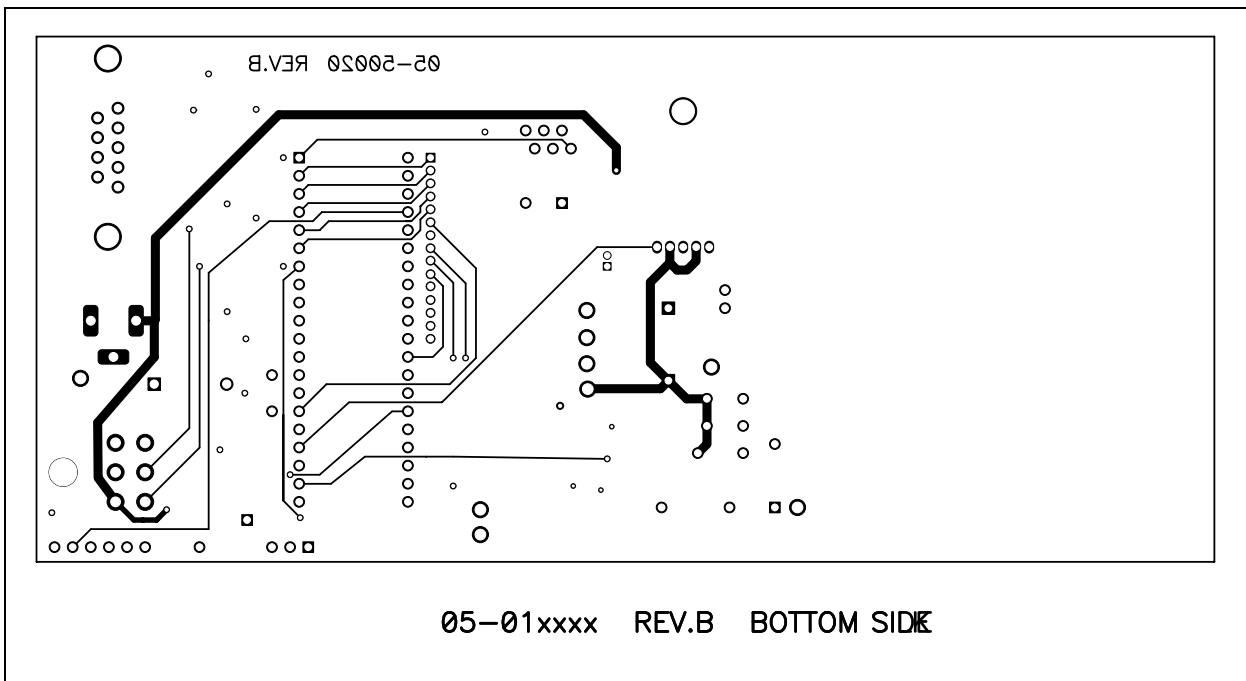

FIGURE C-4: BOTTOM MASK VIEW OF BASE STATION



APPENDIX D: BILL OF MATERIALS

FIGURE D-1: TRANSPONDER BOM

Qty	Component Name	RefDes	Value	Description	Mfr.	Mfr. P/N	Notes
1	BTH-20MM-PTH-MTL	BT1	3V/6V	20MM THRU HOLE MT COIN HOLDER	Keystone® Electronics	3003	
1	CAP-0603-DOUBLE	CX	180pF	CAP,180PF,50V,CERAMIC,0603,SMD	Panasonic®	ECJ-1VC1H181J	
2	CAP-0603-DOUBLE	CY CZ	220pF	CAP,220PF,50V,CERAMIC,0603,SMD	Panasonic	ECJ-1VC1H221J	
2	CAP-CRCW0603	C5 C9	1uF	CAP 1UF 16V CERAMIC F 0603	Panasonic	ECJ-1VF1C105Z	
1	CAP-CRCW0603	C2	0.5pF	CAP,0.5PF,50V,CERAMIC,0603,SMD	Panasonic	ECJ-1VC1H0R5C	
1	CAP-CRCW0603	C3	18pF	CAP,18PF,50V,CERAMIC,0603,SMD	Panasonic	ECJ-1VC1H180J	
2	CAP-CRCW0603	C7a C7b	10uF	CAP CER 10UF 10V 10% X5R 0805	Murata® Electronics	GRM21BR61A106KE19L	
2	CAP-CRCW0603	C4 C6	100nF	CAP CER 0.10UF 50V X7R 10% 0603	TDK	C1608X7R1H104K	
1	CAP-CRCW0603	C8	100pF	CAP CERAMIC 100PF 50V NP0 0603	BC Components	VJ0603A101JXACW1BC	
1	CAP-CRCW0603	C13	300pF	CAP CERM 300PF 5% 50V C0G 0603	Rohm®	MCH185A301JK	
1	CAP-CRCW0603	C1	470pF	CAP,470PF,50V,CERAMIC,0603,SMD	Panasonic	ECU-V1H471KBV	
2	CAP-CRCW1206	C11 C12	1uF	CAP 1UF 25V CERAMIC X7R 1206	Panasonic	ECJ-3YB1E105K	
1	CAP-CRCW1206	C10	10uF	CAP 10UF 16V CERAMIC F 1206	Panasonic	ECJ-3YF1C106Z	
2	DIO-1N4148WS-SOD-323	D3 D7	1N4148WS	DIODE SWITCH 75V 200MW SOD-323	Diodes Inc.	1N4148WS-7	
1	DIO-MA2S784-SS-MINI	D1	MA2S784	DIODE SCHOTTKY 30V 100MA SS-MINI	Panasonic	MA2S784-(TX)	
1	DIO-ZENER-BZX84-SOT23	D2	5.1V	DIODE ZENER 5.1V 0.35W SOT-23	Fairchild® Technologies	BZX84C5V1	
1	HDR-1X6	J2	1X6	CONN HEADER 1X6 .100" PITCH	Samtec®	TSW-106-07-S-S	
1	ICP-PIC16F639/P-20PIN-PDIP	U1	PIC16F639/P	PIC, MICROCHIP, 16F639, 20-PIN, PDIP	Microchip	PIC16F639P	
1	IND-AIR-9MH-PINS-INSIDE	LX	9.0mH	COIL, AIR, CREDIT CARD, 40AWG	Amatech	10-00269	
3	IND-PROTO2	LX_ALT	7.1mH	INDUCTOR,RFID,TRANSPONDER	Coilcraft, Inc	4308RV-715XJBD	DO NOT STUFF LX_ALT
	IND-PROTO2	LY	7.1mH				
	IND-PROTO2	LZ	7.1mH				
3	JMP-2PIN-VIAS	JP1 JP3 JP10	1X2	CONN HEADER 1X2 .100" PITCH	Samtec	TSW-102-07-S-S	
7	JMP-3PIN-VIAS	JP2 JP4 JP5 JP6 JP7 JP8 JP9	1X3	CONN HEADER 1X3 .100" PITCH	Samtec	TSW-103-07-S-S	

FIGURE D-1: TRANSPONDER BOM (CONTINUED)

Qty	Component Name	RefDes	Value	Description	Mfr.	Mfr. P/N	Notes
3	LED-SML-LX231C-TR-RED-2X3MM-SM	D4 D5 D6	RED	LED 2X3MM 635NM RED WTR CLR SMD	Lumex®	SML-LX231C-TR	
5	RES-CRCW0603	R6 R10 R12 R14 R16	4.7K	RES 4.75K OHM 1/10W 1% 0603 SMD	Yageo®	9C06031A4751FKHFT	
1	RES-CRCW0603	R4	10	RES 10.0 OHM 1/10W 1% 0603 SMD	Yageo	9C06031A10R0FKHFT	
1	RES-CRCW0603	R1	47	RES 47.0 OHM 1/16W 1% 0603 SMD	Yageo	9C06031A47R0FKHFT	
1	CRCW0603	R2	47K	RES 47.0K OHM 1/16W 1% 0603 SMD	Yageo	9C06031A4702FKHFT	
2	CRCW0603	R13 R18	100K	RES 100K OHM 1/10W 1% 0603 SMD	Yageo	9C06031A1003FKHFT	
1	CRCW0603	R3	220	RES 220 OHM 1/16W 1% 0603 SMD	Yageo	9C06031A2200FKHFT	
1	CRCW0603	R19	270	RES 270 OHM 1/16W 1% 0603 SMD	Yageo	9C06031A2700FKHFT	
6	CRCW0603	R5 R11 R15 R17 R22 R23	475	RES 475 OHM 1/16W 1% 0603 SMD	Yageo	9C06031A4750FKHFT	
2	CRCW1206	R7 R9	10M	RES 10.0M OHM 1/10W 1% 0603 SMD	Yageo	9C12063A1005FKHFT	
1	CRCW1206	R8	Rlimit 1.7	RES 1.00 OHM 1/4W 1% 1206 SMD	Yageo	9C12063A1R00FGHFT	
1	CRCW0603	U2	433.92MHz	RESONATOR SAW 433.92MHZ 1 PORT	ECS Electronics	ECS-SDR1-4339-TR	
6	SWT-EVQ-PLMA15	SW0 SW1 SW2 SW3 SW4 SW5	MOM-NO	LIGHT TOUCH SWITCH SMD 260GF 5MM	Panasonic	EVQ-PLMA15	
1	TRS-NE94433-SOT23-3	Q1	NE-94433	TRANS NPN OSC FT=2GHZ SOT-23	NEC® Electronics	NE94433-T1B	
5	TSP-P60R38	TP1 TPC TPX TPY TPZ	RFPEN	TEST POINT PC MINI .040"D WHITE	Keystone Electronics	5002	
1	CR2032 3V BATTERY	ST1	Lithium Cell	BATTERY 20MM LITHIUM COIN	Panasonic-BSG	CR2032	
10	SHORTING SHUNT	J1-J10	Shunt	CONN JUMPER SHORTING SHUNT TIN	Sullins®	STC02SYAN	
1	SOCKET 20-PIN	SU1	Socket	PCB TRANSPONDER CC W/GND	Mill-Max®	110-99-320-41-001000	
1	PCB	PCB1	PCB	PLANE	Microchip	05-50011_RevB.pcb	

FIGURE D-2: BASE STATION BOM

Qty	Component Name	RefDes	Value	Description	Mfr.	Mfr. P/N	Notes
1	ANTENNA-LEAD	A1	6.8"	20MM THRU HOLE MT COIN HOLDER	Keystone® Electronics	3003	
2	CAP-200LS-NONPOLAR CAP-200LS-NONPOLAR	C3 C4	0.200LS	CAP.180PF.50V.CERAMIC,0603,SMD	Panasonic®	ECJ-1VC1H181J	
1	CAP-250LS-NONPOLAR	C5	1.0nF	CAP.220PF.50V.CERAMIC,0603,SMD	Panasonic	ECJ-1VC1H221J	
1	CAP-375LS-NONPOLAR	C6	2.2nF	CAP 1UF .16V CERAMIC F 0603	Panasonic	ECJ-1VF1C105Z	
5	CAP-CRCW1206 CAP-CRCW1206 CAP-CRCW1206 CAP-CRCW1206 CAP-CRCW1206 CAP-CRCW1206	C1 C7 C10 C16 C24	0.1uF	CAP.0.5PF.50V.CERAMIC,0603,SMD	Panasonic	ECJ-1VC1H0R5C	
2	CAP-CRCW1206 CAP-CRCW1206	C9 C12	10nF	CAP.18PF.50V.CERAMIC,0603,SMD	Panasonic	ECJ-1VC1H180J	
2	CAP-CRCW1206 CAP-CRCW1206	C22 C23	20pF	CAP CER 10UF 10V 10% X5R 0805	Murata® Electronics	GRM21BR61A106KE19L	
1	CAP-CRCW1206	C8	100pF	CAP CER 0.10UF 50V X7R 10% 0603	TDK	C1608X7R1H104K	
1	CAP-CRCW1206	C11	150pF	CAP CERAMIC 100PF 50V NP0 0603		VJ0603A101JXACW1BC	
1	CAP-ECQ-P4103JU	C2	10nF	CAP CERM 300PF 5% 50V C0G 0603	Rohm®	MCH185A301JK	
1	CAP-EIA3216-A	C15	10uF	CAP.470PF.50V.CERAMIC,0603,SMD	Panasonic	ECU-V1H471KBV	
2	CAP-CRCW0805 CAP-CRCW0805	C17 C18	1uF	CAP 1UF 25V CERAMIC X7R 1206	Panasonic	ECJ-3YB1E105K	
1	CAP-RAD-160D060S	C14	47uF	CAP 10UF 16V CERAMIC F 1206	Panasonic	ECJ-3YF1C106Z	
1	CAP-RAD-400D200S	C13	100uF	DIODE SWITCH 75V 200MW SOD-323	Diodes Inc.	1N4148WS-7	
1	CNN-DB9-MALE-RA-PTH	J2	DE-9P (Male)	DIODE SCHOTTKY 30V 100MA SS-MINI	Panasonic	MA2S784(TX)	
1	CNN-POWER-IN-MOD-2.5MM	J4	2.5mm	DIODE ZENER 5.1V 0.35W SOT-23	Fairchild® Technologies	BZX84C5V1	
1	RJ11_6PIN	J3	ICD	CONN HEADER 1X6 .100" PITCH	Samtec®	TSW-106-07-S-S	
1	AMP770969	J1		PIC, MICROCHIP, 16F639, 20-PIN, PDIP	Microchip	PIC16F639/P	
2	DIO-10MQ100N-SMA-SMT DIO-10MQ100N-SMA-SMT	D5 D8	10MQ100N	COIL, AIR, CREDIT CARD, 40AWG	Amatech	10-00269	
1	DIO-UJ-1005-PTH-DO-41	D1	UF1005	INDUCTOR,RFID,TRANSPONDER	Coilcraft, Inc	4308RV-715XJBD	
1	DIODE-DO214AA	D7	1N4148	DIODE SWITCH 75V 500MW MINIMELF	Diodes Inc.	LL4148-13	
4	DIODE-DO214AA DIODE-DO214AA DIODE-DO214AA DIODE-DO214AA	D4 D9 D10 D11	1N5819	RECT SCHOTTKY 1A 40V DO-214AA	Micro Comm.	SMB5819	
1	DIODE-DO-41	D6	1N4750	DIODE ZENER 27V 1W 5% DO-41	Diodes Inc.	1N4750A-T	
1	ICA-MCP6022/SN-SOIC-8PIN	U2	MCP6022		Microchip	MCP6022-I/SN	
1	MCP201-SO8-150	U5	MCP201		Microchip	MCP201-I/SN	
1	ICA-TC4422CAT-T0220-5LEAD	U1	TC4422CAT		Microchip	TC4422CAT	
1	ICP-PIC18F4680/P-40PDIP	U3	PIC18F458/P		Microchip	PIC18F458-I/P	
1	MCP2551-SO8	U6	MCP2551		Microchip	MCP2551-I/SN	

FIGURE D-2: BASE STATION BOM (CONTINUED)

Qty	Component Name	RefDes	Value	Description	Mfr.	Mfr. P/N	Notes
1	IND-AIR-10-00189-500V-P1H	L1	160uH	IND 160UH 500V AIR	WireBenders®	10-00189	
1	IND-DO5022P-SMT	L2	DO5022P	IND	Colicraft, Inc.		Do Not Populate
1	LCD_2X16_COG	LCD1	{Value}	LCD	United Radiant	UMSH-3112JNV-1G	
2	LED-SML-LX231C-TR-RED-2X3MM-SM	D2 D3	GRN	LED 2X3MM 565NM GRN WTR CLR SMD	Lumex	SML-LX23GC-TR	
1	RES0805	R14	1K	RES 1.00K OHM 1/8W 1% 0805 SMD	Yageo	9C08052A1001FKHFT	
1	RES0805	R13	4.7K	RES 4.75K OHM 1/8W 1% 0805 SMD	Yageo	9C08052A4751FKHFT	
2	RES0805	R18	15K	RES 15.0K OHM 1/8W 1% 0805 SMD	Yageo	9C08052A1502FKHFT	
2	RES0805	R17 R20	25K	RES 24.9K OHM 1/8W 1% 0805 SMD	Yageo	9C08052A12492FKHFT	
1	RES0805	R15	120	RES 121 OHM 1/8W 1% 0805 SMD	Yageo	9C08052A1210FKHFT	Do Not Populate
1	RES0805	R21	Do Not Pop.	RES 121 OHM 1/8W 1% 0805 SMD	Yageo		
1	RES0805	R25	0	RES 0.0 OHM 1/8W 5% 0805 SMD	Yageo	9C08052A0R00JLHFT	
1	RES-CRCW1206	R12	1K	RES 1.00K OHM 1/4W 1% 1206 SMD	Yageo	9C12063A1001FKHFT	
1	RES-CRCW1206	R6	3.92K	RES 3.92K OHM 1/4W 1% 1206 SMD	Yageo	9C12063A3921FKHFT	
1	RES-CRCW1206	R9	4.87K	RES 4.87K OHM 1/4W 1% 1206 SMD	Yageo	9C12063A4871FKHFT	
1	RES-CRCW1206	R3	4.99K	RES 4.99K OHM 1/4W 1% 1206 SMD	Yageo	9C12063A4991FKHFT	
4	RES-CRCW1206	R1 R2 R11 R22	4.99M	RES 4.99M OHM 1/4W 1% 1206 SMD	Yageo	9C12063A4994FKHFT	
1	RES-CRCW1206	R10	5.11K	RES 5.11K OHM 1/4W 1% 1206 SMD	Yageo	9C12063A5111FKHFT	
1	RES-CRCW1206	R7	16.5K	RES 16.5K OHM 1/4W 1% 1206 SMD	Yageo	9C12063A1652FKHFT	
2	RES-CRCW1206	R23 R24	49.9K	RES 49.9K OHM 1/4W 1% 1206 SMD	Yageo	9C12063A4992FKHFT	
1	RES-CRCW1206	R8	78.7K	RES 78.7K OHM 1/4W 1% 1206 SMD	Yageo	9C12063A7872FKHFT	
1	RES-CRCW1206	R4	80.6K	RES 80.6K OHM 1/4W 1% 1206 SMD	Yageo	9C12063A8062FKHFT	
1	RES-CRCW1206	R5	162K	RES 162K OHM 1/4W 1% 1206 SMD	Yageo	9C12063A1623FKHFT	
1	RES-CRCW1206	R16	270	RES 270 OHM 1/4W 1% 1206 SMD	Yageo	9C12063A2700FKHFT	
1	RF-MODULE-RR8	U4	433.92MHz	RR8 433.92MHZ ASK RF RECEIVER	Tellicontrolli	AMHRR3-433	
7	TSP-P90R60	TP1 TP2 TP3 TP4 TP5 TP6 TP7	WHI	TEST POINT PC MULTI PURPOSE WHI	Keystone Electronics	5012	
2	TSP-P90R60	TP8 TP9	BLK	TEST POINT PC MULTI PURPOSE BLK	Keystone Electronics	5011	

FIGURE D-2: BASE STATION BOM (CONTINUED)

Qty	Component Name	RefDes	Value	Description	Mfr.	Mfr. P/N	Notes
1	VRG-5.0V-ZMR500F-SOT23 (223)	VR1	LM3480IM3-5.0	IC 5.0 100MA LDO VREG SOT23	National Semiconductor	LM3480IM3-5.0	
1	XTL-200LS-PTH-CAN	Y1	20.0MHz	CRYSTAL 20.000MHZ 20PF HC-49/US	ECS Inc.	ECS-200-20-4	
1	SOC-SOCKET-MACH.PINS-40-PIN	SU3	40-PIN	IC SOCKET 40PIN MS TIN/TIN .600	Mill-Max Corp.	110-93-640-41-001000	
1	PCB-BLANK	PCB1			Microchip	05-50020_RevB	
1	BUZZER	BZ1		AUD SIG DEVICE 3-20VDC PCB	Mallory Sonalert	MSR320	
1	NO PATTERN - MODIFICATION	Rmod1*	11.0K	RES 11.0K OHM 1/4W 1% METAL FILM	Yageo	MFR-25FFB-11K0	
1	NO PATTERN - MODIFICATION	Dmod1*	1N41418	RECTIFIER SILICON .15A 75V DO-35	Micro Commercial	1N4148	

AN1024

NOTES:

Note the following details of the code protection feature on Microchip devices:

- Microchip products meet the specification contained in their particular Microchip Data Sheet.
- Microchip believes that its family of products is one of the most secure families of its kind on the market today, when used in the intended manner and under normal conditions.
- There are dishonest and possibly illegal methods used to breach the code protection feature. All of these methods, to our knowledge, require using the Microchip products in a manner outside the operating specifications contained in Microchip's Data Sheets. Most likely, the person doing so is engaged in theft of intellectual property.
- Microchip is willing to work with the customer who is concerned about the integrity of their code.
- Neither Microchip nor any other semiconductor manufacturer can guarantee the security of their code. Code protection does not mean that we are guaranteeing the product as “unbreakable.”

Code protection is constantly evolving. We at Microchip are committed to continuously improving the code protection features of our products. Attempts to break Microchip's code protection feature may be a violation of the Digital Millennium Copyright Act. If such acts allow unauthorized access to your software or other copyrighted work, you may have a right to sue for relief under that Act.

Information contained in this publication regarding device applications and the like is provided only for your convenience and may be superseded by updates. It is your responsibility to ensure that your application meets with your specifications. MICROCHIP MAKES NO REPRESENTATIONS OR WARRANTIES OF ANY KIND WHETHER EXPRESS OR IMPLIED, WRITTEN OR ORAL, STATUTORY OR OTHERWISE, RELATED TO THE INFORMATION, INCLUDING BUT NOT LIMITED TO ITS CONDITION, QUALITY, PERFORMANCE, MERCHANTABILITY OR FITNESS FOR PURPOSE. Microchip disclaims all liability arising from this information and its use. Use of Microchip devices in life support and/or safety applications is entirely at the buyer's risk, and the buyer agrees to defend, indemnify and hold harmless Microchip from any and all damages, claims, suits, or expenses resulting from such use. No licenses are conveyed, implicitly or otherwise, under any Microchip intellectual property rights.

Trademarks

The Microchip name and logo, the Microchip logo, Accuron, dsPIC, KEELOQ, KEELOQ logo, microID, MPLAB, PIC, PICmicro, PICSTART, PRO MATE, PowerSmart, rPIC, and SmartShunt are registered trademarks of Microchip Technology Incorporated in the U.S.A. and other countries.

AmpLab, FilterLab, Linear Active Thermistor, Migratable Memory, MXDEV, MXLAB, PS logo, SEEVAL, SmartSensor and The Embedded Control Solutions Company are registered trademarks of Microchip Technology Incorporated in the U.S.A.

Analog-for-the-Digital Age, Application Maestro, CodeGuard, dsPICDEM, dsPICDEM.net, dsPICworks, ECAN, ECONOMONITOR, FanSense, FlexROM, fuzzyLAB, In-Circuit Serial Programming, ICSP, ICEPIC, Mindi, MiWi, MPASM, MPLAB Certified logo, MPLIB, MPLINK, PICkit, PICDEM, PICDEM.net, PICLAB, PICtail, PowerCal, PowerInfo, PowerMate, PowerTool, REAL ICE, rLAB, rfPICDEM, Select Mode, Smart Serial, SmartTel, Total Endurance, UNI/O, WiperLock and ZENA are trademarks of Microchip Technology Incorporated in the U.S.A. and other countries.

SQTP is a service mark of Microchip Technology Incorporated in the U.S.A.

All other trademarks mentioned herein are property of their respective companies.

© 2007, Microchip Technology Incorporated, Printed in the U.S.A., All Rights Reserved.

 Printed on recycled paper.

QUALITY MANAGEMENT SYSTEM
CERTIFIED BY DNV
== ISO/TS 16949:2002 ==

Microchip received ISO/TS-16949:2002 certification for its worldwide headquarters, design and wafer fabrication facilities in Chandler and Tempe, Arizona, Gresham, Oregon and Mountain View, California. The Company's quality system processes and procedures are for its PIC[®] MCUs and dsPIC[®] DSCs, KEELOQ[®] code hopping devices, Serial EEPROMs, microperipherals, nonvolatile memory and analog products. In addition, Microchip's quality system for the design and manufacture of development systems is ISO 9001:2000 certified.



WORLDWIDE SALES AND SERVICE

AMERICAS

Corporate Office
2355 West Chandler Blvd.
Chandler, AZ 85224-6199
Tel: 480-792-7200
Fax: 480-792-7277
Technical Support:
<http://support.microchip.com>
Web Address:
www.microchip.com

Atlanta
Duluth, GA
Tel: 678-957-9614
Fax: 678-957-1455

Boston
Westborough, MA
Tel: 774-760-0087
Fax: 774-760-0088

Chicago
Itasca, IL
Tel: 630-285-0071
Fax: 630-285-0075

Dallas
Addison, TX
Tel: 972-818-7423
Fax: 972-818-2924

Detroit
Farmington Hills, MI
Tel: 248-538-2250
Fax: 248-538-2260

Kokomo
Kokomo, IN
Tel: 765-864-8360
Fax: 765-864-8387

Los Angeles
Mission Viejo, CA
Tel: 949-462-9523
Fax: 949-462-9608

Santa Clara
Santa Clara, CA
Tel: 408-961-6444
Fax: 408-961-6445

Toronto
Mississauga, Ontario,
Canada
Tel: 905-673-0699
Fax: 905-673-6509

ASIA/PACIFIC

Asia Pacific Office
Suites 3707-14, 37th Floor
Tower 6, The Gateway
Harbour City, Kowloon
Hong Kong
Tel: 852-2401-1200
Fax: 852-2401-3431

Australia - Sydney
Tel: 61-2-9868-6733
Fax: 61-2-9868-6755

China - Beijing
Tel: 86-10-8528-2100
Fax: 86-10-8528-2104

China - Chengdu
Tel: 86-28-8665-5511
Fax: 86-28-8665-7889

China - Fuzhou
Tel: 86-591-8750-3506
Fax: 86-591-8750-3521

China - Hong Kong SAR
Tel: 852-2401-1200
Fax: 852-2401-3431

China - Qingdao
Tel: 86-532-8502-7355
Fax: 86-532-8502-7205

China - Shanghai
Tel: 86-21-5407-5533
Fax: 86-21-5407-5066

China - Shenyang
Tel: 86-24-2334-2829
Fax: 86-24-2334-2393

China - Shenzhen
Tel: 86-755-8203-2660
Fax: 86-755-8203-1760

China - Shunde
Tel: 86-757-2839-5507
Fax: 86-757-2839-5571

China - Wuhan
Tel: 86-27-5980-5300
Fax: 86-27-5980-5118

China - Xian
Tel: 86-29-8833-7250
Fax: 86-29-8833-7256

ASIA/PACIFIC

India - Bangalore
Tel: 91-80-4182-8400
Fax: 91-80-4182-8422

India - New Delhi
Tel: 91-11-4160-8631
Fax: 91-11-4160-8632

India - Pune
Tel: 91-20-2566-1512
Fax: 91-20-2566-1513

Japan - Yokohama
Tel: 81-45-471-6166
Fax: 81-45-471-6122

Korea - Gumi
Tel: 82-54-473-4301
Fax: 82-54-473-4302

Korea - Seoul
Tel: 82-2-554-7200
Fax: 82-2-558-5932 or
82-2-558-5934

Malaysia - Penang
Tel: 60-4-646-8870
Fax: 60-4-646-5086

Philippines - Manila
Tel: 63-2-634-9065
Fax: 63-2-634-9069

Singapore
Tel: 65-6334-8870
Fax: 65-6334-8850

Taiwan - Hsin Chu
Tel: 886-3-572-9526
Fax: 886-3-572-6459

Taiwan - Kaohsiung
Tel: 886-7-536-4818
Fax: 886-7-536-4803

Taiwan - Taipei
Tel: 886-2-2500-6610
Fax: 886-2-2508-0102

Thailand - Bangkok
Tel: 66-2-694-1351
Fax: 66-2-694-1350

EUROPE

Austria - Wels
Tel: 43-7242-2244-39
Fax: 43-7242-2244-393

Denmark - Copenhagen
Tel: 45-4450-2828
Fax: 45-4485-2829

France - Paris
Tel: 33-1-69-53-63-20
Fax: 33-1-69-30-90-79

Germany - Munich
Tel: 49-89-627-144-0
Fax: 49-89-627-144-44

Italy - Milan
Tel: 39-0331-742611
Fax: 39-0331-466781

Netherlands - Drunen
Tel: 31-416-690399
Fax: 31-416-690340

Spain - Madrid
Tel: 34-91-708-08-90
Fax: 34-91-708-08-91

UK - Wokingham
Tel: 44-118-921-5869
Fax: 44-118-921-5820