

Tire Pressure Monitoring (TPM) System

*Authors: Ruan Lourens
Microchip Technology Inc.
Curtis Kell
Kell Laboratories*

An auto-location system can dynamically detect the position of a specific sensor, which is useful when tires are rotated. The heart of the TPM system is the Sensor/Transmitter (S/TX) device and it is based on Microchip's rfPIC12F675.

INTRODUCTION

This document explains a typical tire pressure monitoring (TPM) system specifically intended for automotive use. It serves as a reference to design a real-world system based on various Microchip products. A TPM system primarily monitors the internal temperature and pressure of an automobile's tire. There is a variety of system approaches to follow, although this one is a rather comprehensive auto-location system.

SYSTEM COMPONENTS

The TPM system consists of the following major component.

- Sensor/Transmitter Device
- RF Receiver Module
- Low-Frequency (LF) Commander Device
- Control Unit
- Pressure Vessel (Tire)

FIGURE 1: TIRE PRESSURE MONITORING (TPM) SYSTEM

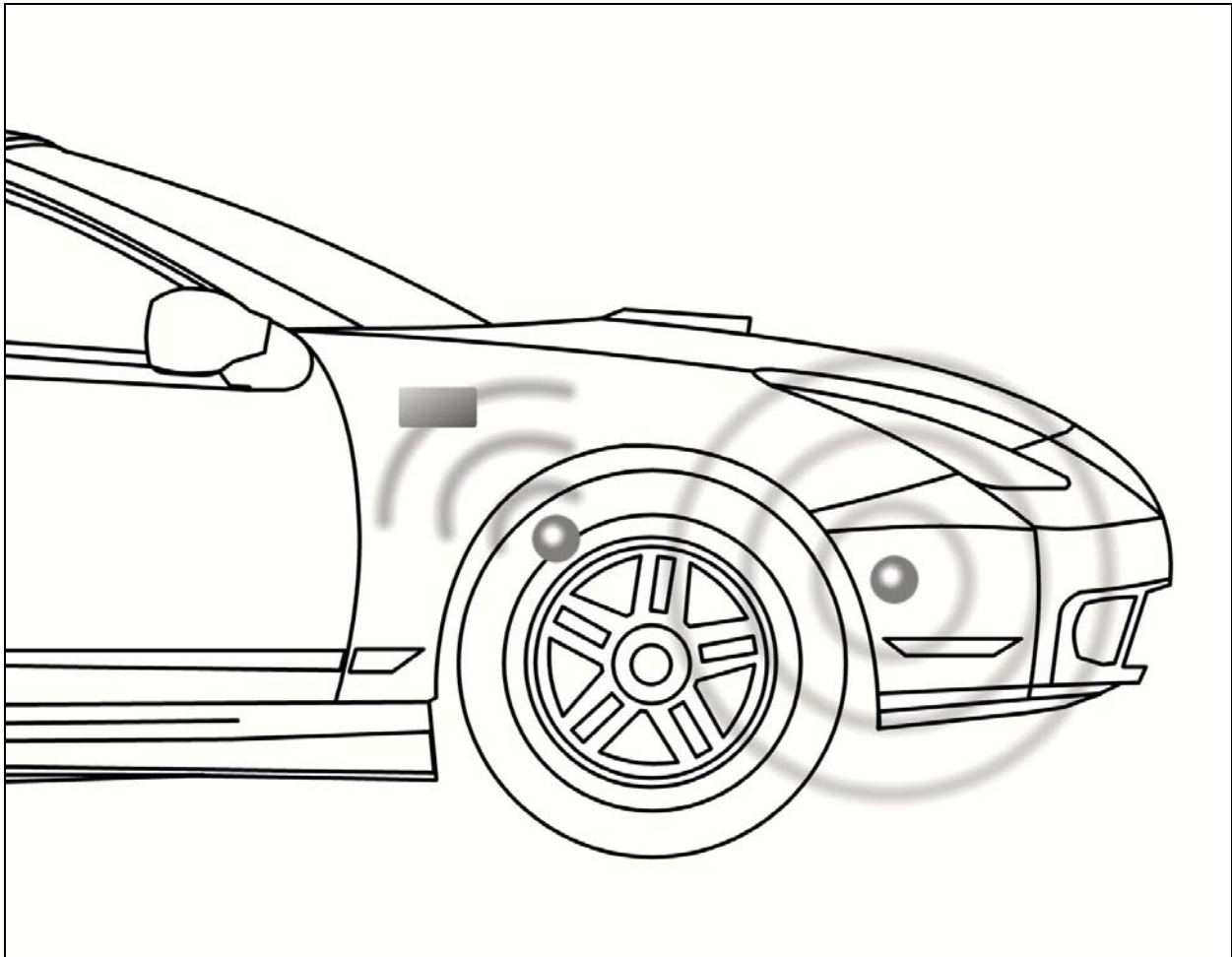

Sensor/Transmitter (S/TX) Device

There are typically five S/TX units per vehicle, one per wheel, and the spare tire. Each unit has a unique serial number enabling the system to distinguish between each tire. When mounted within a vehicle tire, the S/TX periodically measures internal tire pressure, temperature and battery condition. It then sends a RF signal composed of the measured information to a central receiver. The device described in this document is based on Microchip's rPIC12F675 and the pressure and temperature sensing is performed by the Sensoror SP-13, a sensor IC (www.sensoror.com). The unit is also equipped with a LF receiver unit, used to communicate to the S/TX device and to enable it from a Sleep state.

RF Receiver Module

A central RF receiver module receives transmissions from the individual S/TX devices. The receiver can also be used as a remote keyless entry receiver, saving on overall system cost. The design of the RF receiver module falls beyond the intent of this document. A functional RF receiver module is assumed.

LF Commander Device

The LF commander is designed to send specific commands to the S/TX unit via a 125 kHz ASK modulated signal. The LF link communicates over a short distance (1 meter or less), thus making it capable of communicating with the wheel in its immediate range. LF magnetic communications is well suited for sending commands to the S/TX devices. These commands, when received by the S/TX device, instruct it to carry out specific tasks.

Control Unit

The control unit is responsible for initiating communications, interpreting received data and reporting the relevant information back to the vehicle. The unit will only be treated from a system overview perspective.

Pressure Vessel

The pressure vessels (tires) are the measurement subjects, with pressure and temperature values measured and reported.

TPM Sensor/Transmitter

TECHNICAL SPECIFICATIONS

- Modulation Format: ASK
- Operating Voltage: 2.5-3.6V
- Low-Voltage Alert Threshold: 2.5V
- Quiescent Current: TBD

RF Specific:

- Transmit Frequency: 315 MHz
- Transmit Interval: 60, 15 or 5 seconds (LF selectable)
- Power Output: +9 dBm into 50 Ω load
- Operating Current – Transmit: 12.5 mA at max RF power

LF Specific:

- Input Frequency: 125 kHz
- Input Sensitivity: TBD

Pressure Sensor Specific:

- Pressure Sensor Range: 50-637 kPa absolute
- Temperature Sensor Range: -40–125°C

The schematic for the TPM S/TX is shown in **Appendix A: "Schematics"**.

THEORY OF OPERATION

The S/TX device comprises two integrated circuits:

- Microchip's rPIC12F675 MCU/RF transmitter IC
- Sensoror SP-13 (pressure, temperature and low-voltage sensor IC)

In addition, the S/TX also includes LF input circuitry. This circuitry allows the S/TX device to receive special commands via the LF link. Refer to **Appendix A: "Schematics"** for additional circuit detail.

rPIC12F675 Transmitter IC

The rPIC[®] microcontroller, based on the PIC12F675, was chosen as the heart of the S/TX for several reasons. First, the PIC12FXXX series of microcontrollers are widely used for transmitter applications and millions of PIC[®] microcontroller devices are currently used in transmitter applications today. Second, this device features an internal RC oscillator, thereby reducing the external component count which, directly reduces module cost as well as circuit board size. Third, this device includes the RF transmitter circuitry, which again reduces external component count, cost and overall size of the circuit board. The rPIC12F675 also has an internal comparator which plays an important role in decoding the information from the LF link. The internal comparator helps reduce overall part count, thereby further reducing module cost and circuit board size. Lastly, the rPIC12F675 features a 10-bit Analog-to-Digital converter, allowing the designer to use analog output pressure sensors.

The rPIC microcontroller performs three functions. It monitors the data line from the SP-13 sensor IC and from the LF input, and assembles and transmits a RF message at periodic intervals.

After application of power, the rfPIC microcontroller executes an initialization procedure and goes into a Sleep mode until a state change is detected on either the SP-13 data line or the LF input. Either of these inputs generates a wake-up, causing the rfPIC microcontroller to transition into the Run mode. If the wake-up was generated by the SP-13, the rfPIC microcontroller reads the incoming data, assembles the data into an appropriate message, and transmits the message via the RF transmitter. Once the RF message is sent, the rfPIC microcontroller reenters the Sleep mode. If the wake-up was generated by the LF input, the rfPIC microcontroller interprets the LF message, executes the command and then reenters the Sleep mode.

RF Circuitry

The PLL style transmitter within the rfPIC microcontroller requires minimum external components to complete the RF transmitter. The fundamental frequency of the transmitter is determined by Y1. To derive the appropriate crystal frequency, simply divide the desired transmit frequency by 32. For example, if the desired transmit frequency is 315 MHz, the crystal frequency is 9.84375 MHz.

Loop antenna L3 is matched to the single-ended RF driver via C3 and C8, which also form the resonant tank. Refer to application note AN831, "Matching Small Loop Antennas to rfPIC™ Devices" (DS00831) and application note AN868, "Designing Loop Antennas for the rfPIC12F675" (DS00868) for additional technical detail on selecting the appropriate component values for your RF application.

Capacitor C4 is selected to provide decoupling for the 3V supply. Be sure the components selected for your application have a self-resonant frequency well above the desired transmit frequency. The filter formed by L2 and R6 further help decouple the high frequency energy from the rest of the circuitry. The R6 also de-Q's the antenna.

The output power of the transmitter circuit can be adjusted via R8, maximum power is obtained when it is left an open circuit. The transmit power can be changed per the "Power Select Resistor Select" table located in the "rfPIC12F675" Data Sheet (DS70091). This is also useful when trying to certify a product to FCC regulations.

FIGURE 2: RF CIRCUITRY

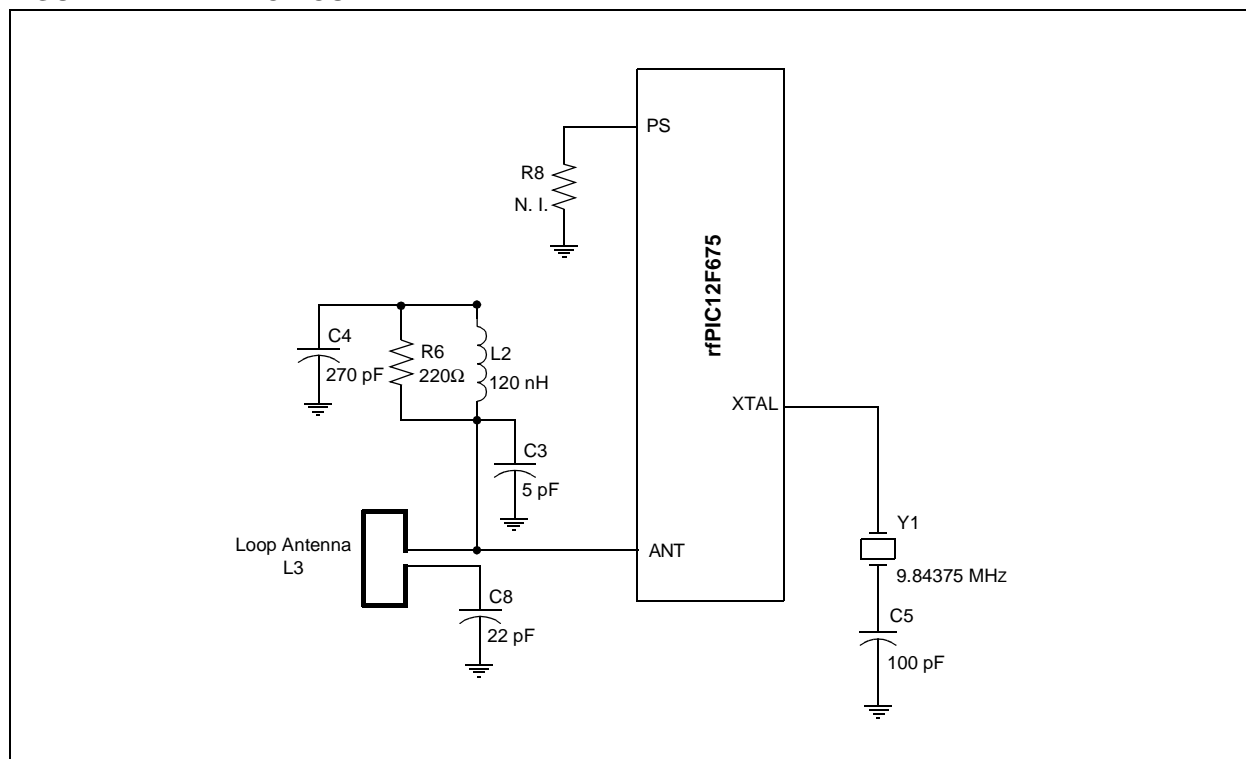

Sensoror SP-13 Sensor IC

The SP-13 sensor IC performs several functions. It measures pressure, temperature, and generates a flag when the battery voltage drops below a predetermined threshold. The SP-13 has five unique modes:

1. **Storage mode:** If the pressure is below 1.5 bar, pressure is measured every 60 seconds but no data is sent. If the pressure increases above 1.5 bars, the component shifts into the Initial mode.
2. **Initial mode:** This mode occurs at power on or if the pressure increases above 1.5 bar from the Storage mode. In this mode, pressure is measured every 0.85 seconds and data is sent every 0.85 seconds. This sequence is repeated 256 times. After the sequence is repeated 256 times, the device shifts into the Normal mode only if pressure is above 1.5 bar. If the pressure is below 1.5 bar, the device will shift into the Storage mode.
3. **Normal mode:** Pressure is measured every 3.4 seconds and data is transmitted every 60 seconds. If the measured pressure differs by more than 200 mbar from the reference taken every 60 seconds, the device enters a Pressure Alert mode.
4. **Pressure Alert mode:** It is the same measurement and transmitting pattern as the Initial mode.
5. **High Temp Alert mode:** If the temperature exceeds 120°C, the SP-13 device enters into the same measurement and transmitting pattern as the Initial mode.

The SP-13 also includes a 32-bit identification number that is programmed into the device at the time of manufacture. This unique ID, when used by the central receiver, allows differentiation between S/TXs.

Sensoror, as well as several other manufacturers, continue to offer enhanced pressure sensing devices of varying functionality. Therefore, it is recommended that a TPM developer thoroughly research the market prior to making a final pressure sensor selection.

FIGURE 3: SENSOROR SP-13 SENSOR IC

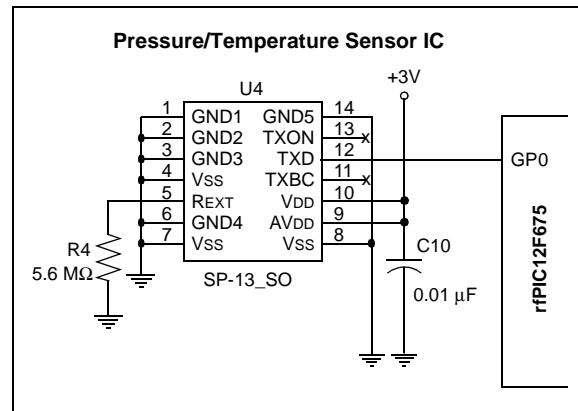

LF Input Circuitry

The LF input is designed to receive and demodulate a 125 kHz signal and transform the received data into a specific command. The LF input circuit makes use of the internal comparator of the rPIC microcontroller, thereby reducing cost, module size and quiescent current. The LF input circuitry features a LC tank circuit that is tuned to 125 kHz. The LF sensing input comprises L1 and C11. L1 is specially designed by Coilcraft for this type of application. It provides good sensitivity in a compact package. A conventional coil could be used in its place, but overall circuit sensitivity or range would be reduced. Schottky diode D3 is used to clamp the voltage developed across the LC tank to safe levels. The output of the LC tank circuit, after passing through current limiting resistor R5, is fed into the rPIC microcontroller comparator's negative input. The comparator's positive input is configured as VREF through the rPIC12F675 VREF module. The output of the comparator is then fed into an envelope detector consisting of Schottky diode D2, capacitor C9 and resistor R3. C9 and R3 are selected to provide adequate filtering of the LF frequency without rounding the edges of the desired data signal. The output of the envelope detector is then fed directly into a port pin on the rPIC microcontroller and used to process the LF data.

Without a limiting diode, the LF input circuit may be prone to being overdriven when strong LF fields are present. This can be seen when the LF commander device is in close proximity to the S/TX device. The envelope detection circuit can be abandoned to reduce cost, but doing so would require additional data extraction software.

FIGURE 4: LF CIRCUITRY

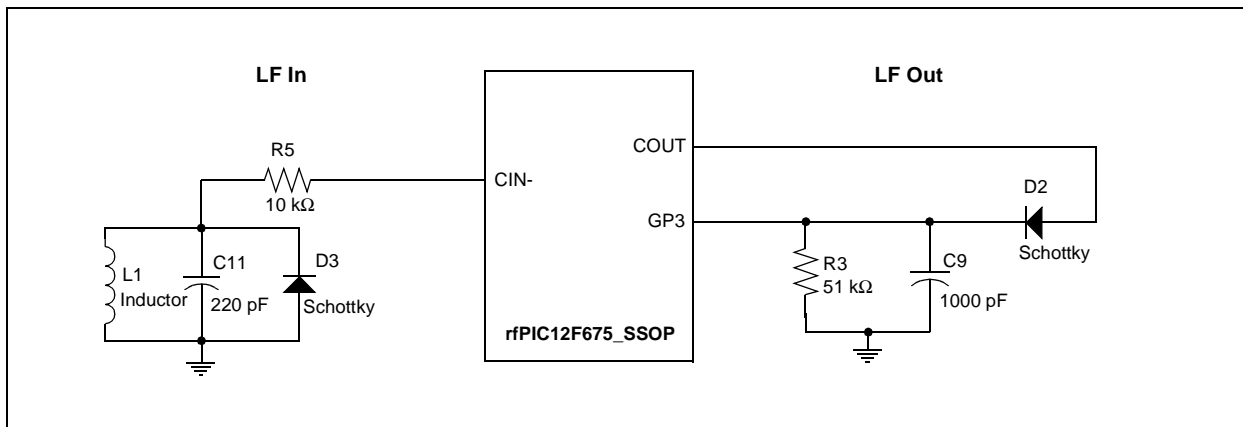

Details of the LF transmission format and the specific commands can be found in the Section “**LF Commander**”.

RF Transmission Format

The encoding method used for this demonstration system is the 1/3-2/3 PWM format with T_E (basic pulse element) time of 400 μ s and a bit period of $3 \times T_E$ or 1.2 ms.

FIGURE 5: RF TRANSMISSION ENCODING METHOD

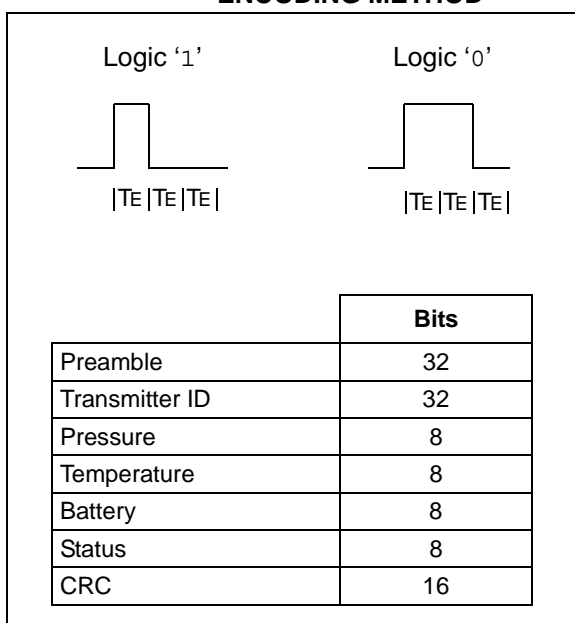

Preamble: The preamble is a series of 31 logic ‘1’ bits followed by a single logic ‘0’ bit. The preamble allows the receiver to recognize the RF transmission as a valid S/TX message. The preamble also allows the receiver to synchronize to the RF message, thereby compensating for any oscillator inaccuracies within the transmitter. The system designer may vary the number of preamble bits based on system requirements. Longer preamble bit lengths may be appropriate where receiver quiescent current is an issue. Shorter preamble bit lengths may be appropriate where S/TX battery usage is a concern. In either case, it is purely a trade-off between receiver quiescent current and battery power consumed by the S/TX device.

Transmitter ID: The 32 transmitter ID bits are used to uniquely identify each S/TX. A frame of 32 bits ensures that there is a very low probability that any two S/TXs will have the same ID.

Pressure: The pressure in kPa is obtained by multiplying the unsigned binary value of this byte by 2.5.

Temperature: The temperature in degrees C is obtained by subtracting 40 from the unsigned value of byte 8.

Battery: Bit 7 of this byte indicates the battery condition. A logic ‘1’ is considered normal while a logic ‘0’ indicates a low battery voltage.

Status: This status byte contains the following information:

Bits 0 and 1: Indicate operating state of sensor IC

00 = Initial or Storage mode

01 = Normal mode

10 = Pressure Alert mode

11 = Temperature Alert mode

CRC (2 bytes): Implement according to CCITT standards.

LF Commander

THEORY OF OPERATION

The system proposed in this document is based on an auto-location system, enabling it to detect the position of a specific S/TX device. This requires a LF commander device at each wheel arc and possibly at the spare tire mounting position.

Having a handheld LF commander unit can enable a lower cost system. Although, this would require that the system be manually relearned after a tire rotation, the S/TX device is able to detect tire rotation or some other system to engage data transmission. The LF commander device is capable of sending commands to the S/TX device via a LF transmission such as:

- Enable RF transmissions
- Disable RF transmissions
- Transmit an immediate message
- Transmit at 60-second intervals
- Transmit at 15-second intervals
- Transmit at 5-second intervals

The LF commander unit is based on the PIC16F628 MCU device. Communication between the LF commander and the S/TX is accomplished via magnetic field. When the LF commander is transmitting a message, it is essentially creating a magnetic field by exciting a series LC circuit. The LC circuit is excited by the PIC[®] microcontroller PWM port. This port is set up to generate a 50% duty cycle at 125 kHz. The command data is then modulated on this 125 kHz signal in the form of ASK modulation. Functionally, this is accomplished by instructing the PIC microcontroller to toggle the PWM port between 0% and 50% duty cycle at the rate of the data.

LF TRANSMISSION FORMAT

The encoding format used in the LF link is a 1/3-2/3 PWM format with 400 μs TE (basic pulse element). Selecting 400 μs TE or greater ensures the magnetic field generated by the series LC circuit has adequate time to rise and decay, without requiring too much wave shaping of the recovered square wave in the S/TX circuitry.

The transmission data format for the LF link is shown in Figure 6.

FIGURE 6: LF TRANSMISSION ENCODING METHOD

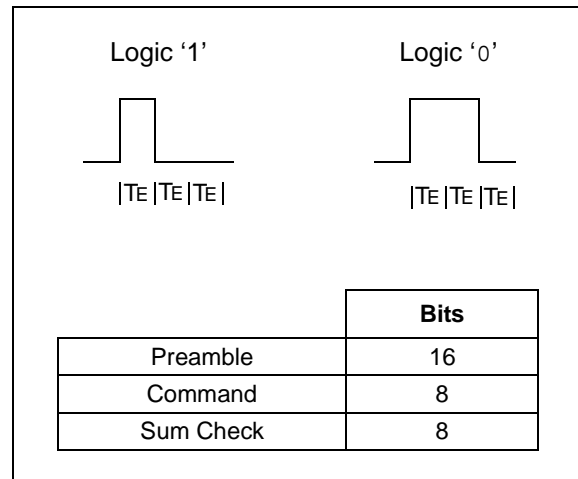

Preamble: The preamble is a series of 15 logic '1' bits and 1 logic '0' bit. This reduces the chance of the S/TX receiving erroneous data from electronic devices that generate strong 125 kHz fields. Computer CRTs and switching power supplies are examples of such devices.

Command: These 8 bits of data contains the specific command that the S/TX is being asked to perform. Table 1 illustrates the various commands (MSB is left most column).

TABLE 1: BIT FUNCTIONS

Bits	Function
01101101	Enable RF transmissions
10010010	Disable RF transmissions
10101010	Transmit an immediate RF message
10110110	Transmit at 60-second interval
11001100	Transmit at 15-second interval
11010011	Transmit at 5-second interval

Sum Check: Calculated by adding contents of the command byte with '10101010'.

SUMMARY

TPM use in the automotive industry is growing, driven by customer demand, improved safety, and possible compulsory-usage legislation. Microchip's low-cost rfPIC devices are well suited for the application and help reduce the overall TPM system cost.

The use of rfPIC microcontroller-based S/TX makes for a flexible solution that allows for the merging with existing systems such as security, PKE, RKE and more.

FIGURE 7: PHOTOGRAPH OF SENSOR/TRANSMITTER DEVICE

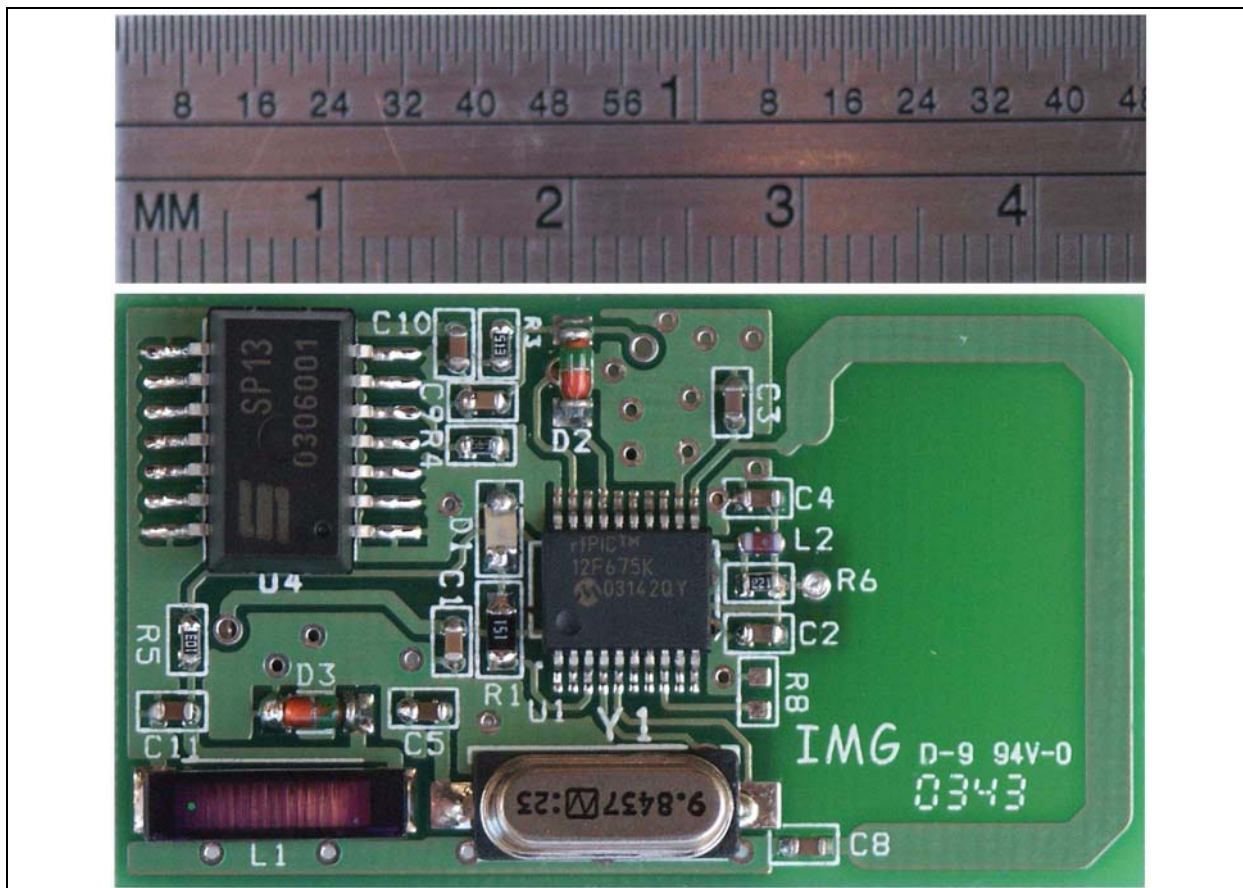

REFERENCE DOCUMENTS

The following reference documents are available from Microchip's web site at www.microchip.com.

1. "*Low-Frequency Magnetic Transmitter Design*" Application Note (AN232), DS00232; Microchip Technology Inc.
2. "*Designing Loop Antennas for the rfPIC12F675*" Application Note (AN868), DS00868; Microchip Technology Inc.
3. "*Matching Small Loop Antennas to rfPIC Devices*" Application Note (AN831), DS00831; Microchip Technology Inc.
4. "*Magnetic Tuning of Resonant Resistors and Methods for Increasing Sensitivity*" Application Note (AN832), DS00832; Microchip Technology Inc.
5. "*Optimizing PLL Filters for the rfPIC12C509A and rfHCS362*" Application Note (AN846), DS00846; Microchip Technology Inc.
6. "*rfPIC12F675*" Data Sheet, DS70091; Microchip Technology Inc.

AN238

NOTES:

Note the following details of the code protection feature on Microchip devices:

- Microchip products meet the specification contained in their particular Microchip Data Sheet.
- Microchip believes that its family of products is one of the most secure families of its kind on the market today, when used in the intended manner and under normal conditions.
- There are dishonest and possibly illegal methods used to breach the code protection feature. All of these methods, to our knowledge, require using the Microchip products in a manner outside the operating specifications contained in Microchip's Data Sheets. Most likely, the person doing so is engaged in theft of intellectual property.
- Microchip is willing to work with the customer who is concerned about the integrity of their code.
- Neither Microchip nor any other semiconductor manufacturer can guarantee the security of their code. Code protection does not mean that we are guaranteeing the product as "unbreakable."

Code protection is constantly evolving. We at Microchip are committed to continuously improving the code protection features of our products. Attempts to break Microchip's code protection feature may be a violation of the Digital Millennium Copyright Act. If such acts allow unauthorized access to your software or other copyrighted work, you may have a right to sue for relief under that Act.

Information contained in this publication regarding device applications and the like is provided only for your convenience and may be superseded by updates. It is your responsibility to ensure that your application meets with your specifications. MICROCHIP MAKES NO REPRESENTATIONS OR WARRANTIES OF ANY KIND WHETHER EXPRESS OR IMPLIED, WRITTEN OR ORAL, STATUTORY OR OTHERWISE, RELATED TO THE INFORMATION, INCLUDING BUT NOT LIMITED TO ITS CONDITION, QUALITY, PERFORMANCE, MERCHANTABILITY OR FITNESS FOR PURPOSE. Microchip disclaims all liability arising from this information and its use. Use of Microchip devices in life support and/or safety applications is entirely at the buyer's risk, and the buyer agrees to defend, indemnify and hold harmless Microchip from any and all damages, claims, suits, or expenses resulting from such use. No licenses are conveyed, implicitly or otherwise, under any Microchip intellectual property rights.

Trademarks

The Microchip name and logo, the Microchip logo, Accuron, dsPIC, KEELOQ, KEELOQ logo, MPLAB, PIC, PICmicro, PICSTART, rfPIC, SmartShunt and UNI/O are registered trademarks of Microchip Technology Incorporated in the U.S.A. and other countries.

FilterLab, Linear Active Thermistor, MXDEV, MXLAB, SEEVAL, SmartSensor and The Embedded Control Solutions Company are registered trademarks of Microchip Technology Incorporated in the U.S.A.

Analog-for-the-Digital Age, Application Maestro, CodeGuard, dsPICDEM, dsPICDEM.net, dsPICworks, dsSPEAK, ECAN, ECONOMONITOR, FanSense, In-Circuit Serial Programming, ICSP, ICEPIC, Mindi, MiWi, MPASM, MPLAB Certified logo, MPLIB, MPLINK, mTouch, PICkit, PICDEM, PICDEM.net, PICtail, PIC³² logo, PowerCal, PowerInfo, PowerMate, PowerTool, REAL ICE, rLAB, Select Mode, Total Endurance, WiperLock and ZENA are trademarks of Microchip Technology Incorporated in the U.S.A. and other countries.

SQTP is a service mark of Microchip Technology Incorporated in the U.S.A.

All other trademarks mentioned herein are property of their respective companies.

© 2009, Microchip Technology Incorporated, Printed in the U.S.A., All Rights Reserved.

 Printed on recycled paper.

QUALITY MANAGEMENT SYSTEM
CERTIFIED BY DNV
== ISO/TS 16949:2002 ==

Microchip received ISO/TS-16949:2002 certification for its worldwide headquarters, design and wafer fabrication facilities in Chandler and Tempe, Arizona; Gresham, Oregon and design centers in California and India. The Company's quality system processes and procedures are for its PIC® MCUs and dsPIC® DSCs, KEELOQ® code hopping devices, Serial EEPROMs, microperipherals, nonvolatile memory and analog products. In addition, Microchip's quality system for the design and manufacture of development systems is ISO 9001:2000 certified.



WORLDWIDE SALES AND SERVICE

AMERICAS

Corporate Office

2355 West Chandler Blvd.
Chandler, AZ 85224-6199
Tel: 480-792-7200
Fax: 480-792-7277
Technical Support:
<http://support.microchip.com>
Web Address:
www.microchip.com

Atlanta

Duluth, GA
Tel: 678-957-9614
Fax: 678-957-1455

Boston

Westborough, MA
Tel: 774-760-0087
Fax: 774-760-0088

Chicago

Itasca, IL
Tel: 630-285-0071
Fax: 630-285-0075

Dallas

Addison, TX
Tel: 972-818-7423
Fax: 972-818-2924

Detroit

Farmington Hills, MI
Tel: 248-538-2250
Fax: 248-538-2260

Kokomo

Kokomo, IN
Tel: 765-864-8360
Fax: 765-864-8387

Los Angeles

Mission Viejo, CA
Tel: 949-462-9523
Fax: 949-462-9608

Santa Clara

Santa Clara, CA
Tel: 408-961-6444
Fax: 408-961-6445

Toronto

Mississauga, Ontario,
Canada
Tel: 905-673-0699
Fax: 905-673-6509

ASIA/PACIFIC

Asia Pacific Office

Suites 3707-14, 37th Floor
Tower 6, The Gateway
Harbour City, Kowloon
Hong Kong
Tel: 852-2401-1200
Fax: 852-2401-3431

Australia - Sydney

Tel: 61-2-9868-6733
Fax: 61-2-9868-6755

China - Beijing

Tel: 86-10-8528-2100
Fax: 86-10-8528-2104

China - Chengdu

Tel: 86-28-8665-5511
Fax: 86-28-8665-7889

China - Hong Kong SAR

Tel: 852-2401-1200
Fax: 852-2401-3431

China - Nanjing

Tel: 86-25-8473-2460
Fax: 86-25-8473-2470

China - Qingdao

Tel: 86-532-8502-7355
Fax: 86-532-8502-7205

China - Shanghai

Tel: 86-21-5407-5533
Fax: 86-21-5407-5066

China - Shenyang

Tel: 86-24-2334-2829
Fax: 86-24-2334-2393

China - Shenzhen

Tel: 86-755-8203-2660
Fax: 86-755-8203-1760

China - Wuhan

Tel: 86-27-5980-5300
Fax: 86-27-5980-5118

China - Xiamen

Tel: 86-592-2388138
Fax: 86-592-2388130

China - Xian

Tel: 86-29-8833-7252
Fax: 86-29-8833-7256

China - Zhuhai

Tel: 86-756-3210040
Fax: 86-756-3210049

ASIA/PACIFIC

India - Bangalore

Tel: 91-80-4182-8400
Fax: 91-80-4182-8422

India - New Delhi

Tel: 91-11-4160-8631
Fax: 91-11-4160-8632

India - Pune

Tel: 91-20-2566-1512
Fax: 91-20-2566-1513

Japan - Yokohama

Tel: 81-45-471- 6166
Fax: 81-45-471-6122

Korea - Daegu

Tel: 82-53-744-4301
Fax: 82-53-744-4302

Korea - Seoul

Tel: 82-2-554-7200
Fax: 82-2-558-5932 or
82-2-558-5934

Malaysia - Kuala Lumpur

Tel: 60-3-6201-9857
Fax: 60-3-6201-9859

Malaysia - Penang

Tel: 60-4-227-8870
Fax: 60-4-227-4068

Philippines - Manila

Tel: 63-2-634-9065
Fax: 63-2-634-9069

Singapore

Tel: 65-6334-8870
Fax: 65-6334-8850

Taiwan - Hsin Chu

Tel: 886-3-572-9526
Fax: 886-3-572-6459

Taiwan - Kaohsiung

Tel: 886-7-536-4818
Fax: 886-7-536-4803

Taiwan - Taipei

Tel: 886-2-2500-6610
Fax: 886-2-2508-0102

Thailand - Bangkok

Tel: 66-2-694-1351
Fax: 66-2-694-1350

EUROPE

Austria - Wels

Tel: 43-7242-2244-39
Fax: 43-7242-2244-393

Denmark - Copenhagen

Tel: 45-4450-2828
Fax: 45-4485-2829

France - Paris

Tel: 33-1-69-53-63-20
Fax: 33-1-69-30-90-79

Germany - Munich

Tel: 49-89-627-144-0
Fax: 49-89-627-144-44

Italy - Milan

Tel: 39-0331-742611
Fax: 39-0331-466781

Netherlands - Drunen

Tel: 31-416-690399
Fax: 31-416-690340

Spain - Madrid

Tel: 34-91-708-08-90
Fax: 34-91-708-08-91

UK - Wokingham

Tel: 44-118-921-5869
Fax: 44-118-921-5820

01/02/08