

Si4133 RF Synthesizer

DUAL-BAND RF FREQUENCY SYNTHESIZER
WITH INTEGRATED VCOs FOR WIRELESS
COMMUNICATIONS



PRODUCT DESCRIPTION

The Si4133 is a monolithic integrated circuit that performs IF and dual-band, low-noise RF frequency synthesis for wireless personal communications applications. The Si4133 addresses the price-sensitive, low-power, high-performance requirements for personal wireless communications by substantially reducing external passive component count, eliminating external VCOs and external varactor diodes, improving power efficiency, and isolating, in silicon, unwanted external interference. The stable, low-phase noise characteristics are achieved through a proprietary self-tuning architecture that does not require external adjustments or laser trimming for component-tolerance matching.

The Si4133 includes three voltage-controlled oscillators, loop filters, reference and VCO dividers, and phase detectors. Variables for dividers, phase detector gain settings, and power-down settings are programmable through a three-wire serial interface (Data, Clock, and Enable) and a 22-bit internal shift register.

The Si4133 comes standard in a low-profile, small-outline, 24-pin package (TSSOP).

Si4133 Enhanced Frequency Synthesizer Block Diagram

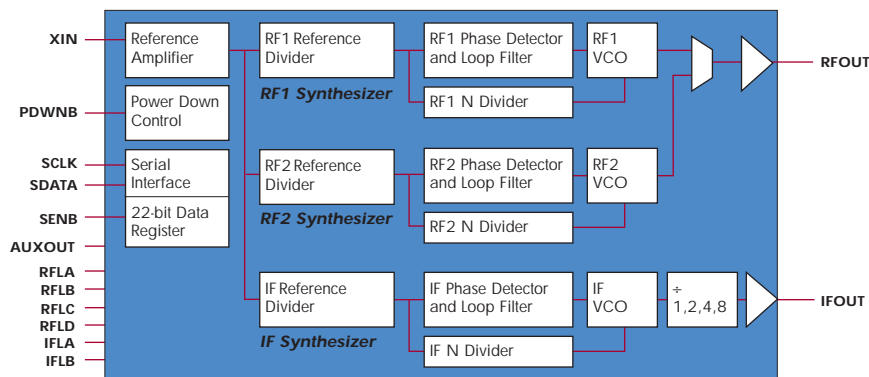

FEATURES

- Dual-band RF Synthesizers:
 - RF1 900 MHz to 1.8 GHz
 - RF2 750 MHz to 1.5 GHz
- IF Synthesizer:
 - IF 62.5 MHz to 1.0 GHz
- High frequency "HF" devices available—
 - Supports frequency synthesis up to 2.4 GHz
- Dual Synthesizer and Single Synthesizer derivatives available
- Fully integrated VCOs
- Programmable loop filters
- Minimal (2) passive external components
- Automatic selection of optimal phase detector gain and modulus prescaler values
- Low phase noise
- Fast settling times (200 μ S for GSM/DCS1800 applications)
- 1 μ A standby current @ 3V
- 18 mA supply current @ 3V
- 2.7V to 3.6V operation

APPLICATIONS

- Dual-band wireless communications
- Digital cellular telephones
- Dual-band ISM terminals:
 - Digital cordless phones
 - Wireless consumer products
 - Wireless industrial applications
- Wireless data communications
- SMR applications

PRODUCT BRIEF

MEETING THE CHALLENGES OF RF
DESIGN WITH INNOVATIVE ANALOG
AND MIXED-SIGNAL SOLUTIONS.
NOW SUPPORTING FREQUENCY
SYNTHESIS UP TO 2.4 GHz.



SILICON LABORATORIES

REDUCTION IN POWER DISSIPATION

The Si4133 uses a proprietary self-calibration architecture that not only results in fast settling times, but also significantly reduces power consumption in the PLL. That, in combination with the Si4133's flexible power-down scheme, provides the lowest overall power consumption in RF synthesizer applications. Integrating all the components of the frequency-synthesis function into a monolithic CMOS device allows the designer to achieve greater control over the power consumption of the entire functional block with one control interface. With active consumption of 18 mA from a 3V supply, the Si4133 sets a new standard in power efficiency.

DEVELOPMENT TOOLS

Design engineers can order the Si4133-EVB which includes an evaluation board that supports all derivative options for the Si4133 family of synthesizers. New user-friendly evaluation software features a windowing interface for easy manipulation of the device from a standard PC. The development environment allows for straightforward assessment of the device's performance using industry-standard test and measurement equipment.

CONTACT INFORMATION



SILICON LABORATORIES

Silicon Laboratories, Inc.
4635 Boston Lane • Austin, TX 78735
Toll Free: 1(877)444-3032
Email: productinfo@silabs.com
Web site: www.silabs.com

Silicon Laboratories, and the Silicon Laboratories' logos are trademarks of Silicon Laboratories, Inc.
PB:Si4133: KES5,000-5/99-0

75% Area Reduction / 33% Cost Savings

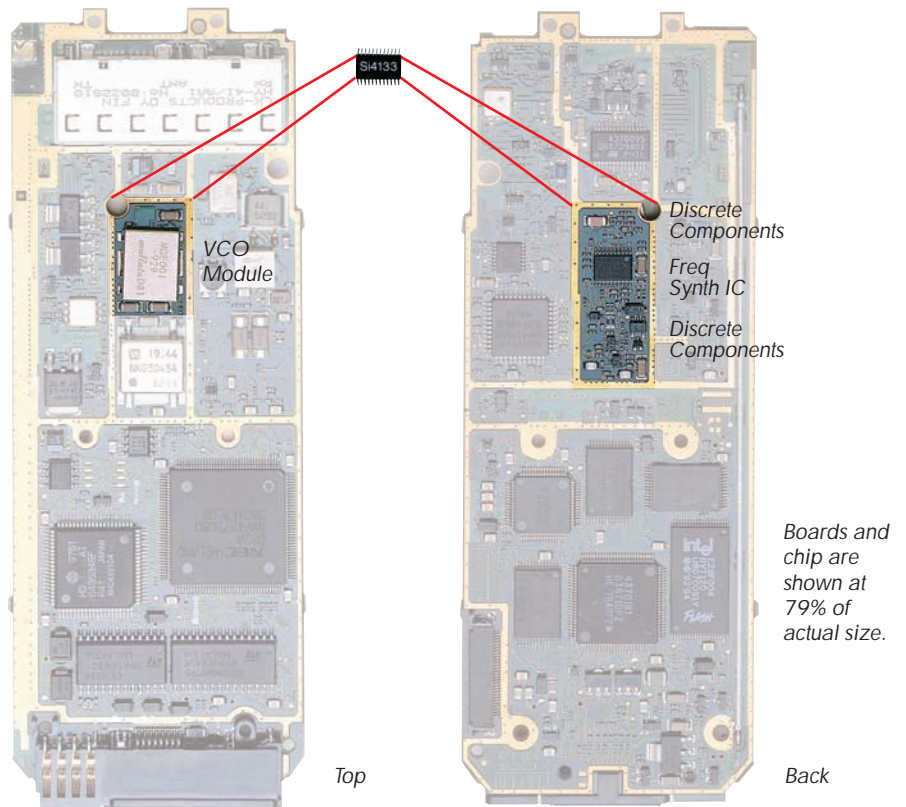

The Si4133 dramatically reduces the number of components required to implement a complete dual-band RF frequency synthesizer function for wireless communications. This unprecedented level of integration can reduce board space by as much as 75% over traditional frequency synthesizer architectures using a dual-band frequency synthesizer IC, external VCOs, varactor diodes and up to 35 additional passive components. Designers can realize cost reductions of 33% over traditional solutions by designing with the Si4133. The robustness and consistency of an integrated solution improves ease of manufacture and lower test and assembly costs for high-volume wireless applications.

ORDERING INFORMATION

Product	Description
Si4133-KT	RF1/RF2/IF Frequency Synthesizer, 24-pin TSSOP, 0 to 70° C
Si4133-BT	RF1/RF2/IF Frequency Synthesizer, 24-pin TSSOP, -40 to 85° C
Si4133HF	RF1 (2.4 GHz)/RF2 (1.7 GHz)/IF Frequency Synthesizer, 24-pin TSSOP
Si4133HF1	RF1 (2.4 GHz)/RF2/IF Frequency Synthesizer, 24-pin TSSOP
Si4123	RF1/IF Frequency Synthesizer, 24-pin TSSOP
Si4122	RF2/IF Frequency Synthesizer, 24-pin TSSOP
Si4113	RF-Only Synthesizer, 24-pin TSSOP
Si4112	IF-Only Synthesizer, 24-pin TSSOP
Si4133-EVB	Si4133 Evaluation Board supports all derivative products