

# EM260

802.15.4 and ZigBee Compliant Network Co-processor

Radio  
2.4GHz

## Fact Sheet

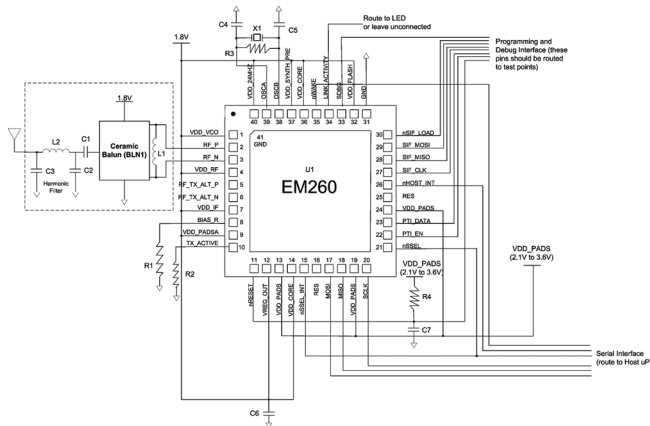

## Extended Features

- Best in class RF performance
- Complete network processor plus radio containing a complete Network level ZigBee implementation
- Simple SPI-Slave or UART interface to an application microcontroller, providing the full serialized EmberZNet PRO 3.1 interface
- Flexible Antenna Interface allows easy antenna connection with or without external PA
- Excellent noise immunity to 802.11 b/g. Exceeds 802.15.4 adjacent/alternate channel rejection specification for improved co-existence
- Digital RSSI/802.15.4 Link Quality Indication
- Hardware supported network level debugging
- Hardware Encryption Engine (AES 128) with true Random Number Generator
- Integrated sleep oscillator allows a single crystal design, reducing cost and power consumption
- Capable of being ZigBee co-ordinator, Full-Functional Device (FFD), and Reduced Functional Device (RFD)

## Overview

The EM260 from Ember is the first network co-processor chip designed for the low power, low cost, ZigBee mesh networking standard. The EM260 is designed to provide customers the flexibility of choosing their own microcontroller to run their application, while interfacing to the EM260 to provide all the ZigBee functionality. The external microcontroller can be sized exactly for the application, from the smallest, most cost-effective 8-bit controller, all the way through high-end 32-bit controllers for applications such as gateways. This flexibility of microcontroller choice allows customers to ZigBee enable existing products very rapidly using tool-chains they are familiar with.

The EM260 integrates an IEEE 802.15.4 2.4GHz unlicensed spectrum ZigBee radio, along with the baseband, network microcontroller and onboard memory to run the protocol stack from the PHY layer to the network layer. It includes built in powerful debug modes including network wide debugging support to rapidly get customers from the design phase into production.

Designed specifically for use with EmberZNet PRO, Ember's ZigBee compliant embedded mesh networking software, the EM260 is optimized for designs requiring long battery life, low external component count, and a reliable, proven, industry-standard networking solution.

## ZigBee Network Co-processor

The EM260's industry proven embedded 16-bit XAP2 microcontroller was specifically chosen to run ZigBee. The microcontroller has excellent low power modes in order to keep the over all power consumption of the ZigBee solution very low, making this solution well suited for battery operated devices that are required to run for many years without changing the batteries.

The EM260's built-in 802.15.4 RF section provides the highest level of integration, requiring only minimal external components. It provides exceptional interference immunity to other 2.4GHz interferers, and excellent receiver sensitivity for long range. For applications requiring even longer range, an easy method of connecting an external PA and/or LNA is provided.

## Microcontroller Interface

The EM260 provides an easy to use network interface over an SPI slave-mode connection (customer micro is SPI master). For larger micros or gateway applications, the EM260 supports a UART interface with RTS/

*(Continued on back)*

CTS flow control. The interface exposes a serialized version of Ember’s EmberZNet PRO API. All EmberZNet PRO network functionality is available, along with additional functionality such as a system battery monitor and a settable wakeup timer. The EM260 handles all processing and timing intensive tasks, such as AES-128 encryption, relaying packets, and handling all aspects of the ZigBee protocol, leaving the customer’s microcontroller free to implement even the most timing critical applications. The ability to run the application on the microcontroller of choice, using tools that customers are already used to enables rapid application development and obviates the need for porting of applications to other microcontrollers, thereby reducing barriers to deployment of products.

**Power**

Applications requiring years of battery life take advantage of the EM260’s low operating and sleep currents and the integrated EmberZNet PRO networking library to easily incorporate short activity cycles. The EM260’s integrated voltage regulator supports a wide range of operating voltages that allows hardware to be optimized for use with lithium-ion or alkaline batteries, without additional circuitry.

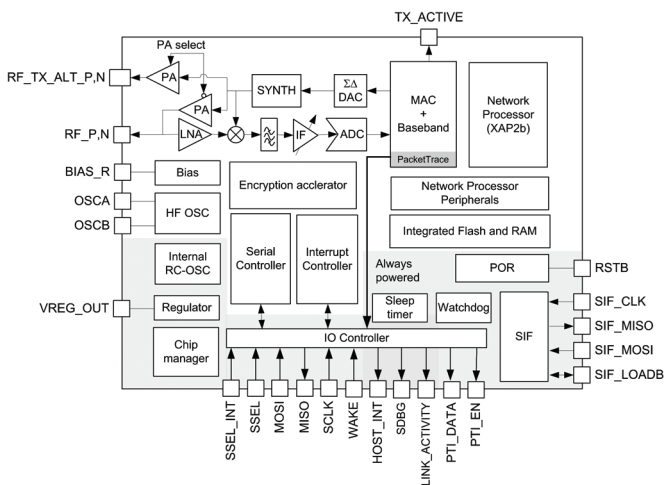

**About Ember**

Ember Corporation develops ZigBee wireless networking technology that enable companies involved in energy technologies—energetch—to help buildings and homes consume less energy, operate more efficiently, and keep people comfortable, safe and secure. Ember low-power wireless technology can be embedded in potentially any device to be part of a self-organizing mesh network. Ember is headquartered in Boston and has its radio development center in Cambridge, England, and distributors worldwide. The company is a promoter and Board member of the ZigBee Alliance and its platform is the “Golden Suite” for 802.15.4/ZigBee interoperability testing.

**US Headquarters**

47 Farnsworth St.  
Boston, MA 02210  
USA  
+1 617 951 0200  
www.ember.com

**European Office**

Cambridge Science Park  
Unit 300, Milton Rd.  
Cambridge, CB4 0XL, UK  
+44 (0) 1223 423322  
www.ember.com

**Asian Office**

22/F, 3 Lockheart Rd.  
Wanchai, Hong Kong  
China  
852-2862 8075  
www.ember.com

**Development**

The EM260’s serialized network interface is available with generic host-side source-code level drivers for SPI and UART implementations. Select microcontroller families will have hardware-specific source code drivers available. Application development can be performed in the customer’s microcontroller of choice, using their tool-chain of choice. Debugging can be performed using standard ICE or JTAG type tools for the chosen microcontroller. In addition, the EM260 is supported by InSight Desktop, which provides network level debugging to quickly identify complicated bugs that can’t be caught by examining a single node. InSight Desktop will also provide EM260 users with a trace of the calls made over the serial connection to help identify issues in the communication between the EM260 and the host microcontroller.

The EM260 provides a serialized interface to EmberZNet PRO, which is Ember’s widely used and well-tested fourth generation embedded mesh networking API, providing a smooth transition for existing users of Ember’s previous generation software and guaranteeing a well supported and low risk introduction for first-time users.

**General Characteristics**

Deep Sleep Current (with sleep timer running)	1 uA max
RX Current	36 mA – Normal Mode; 38 mA - Boost Mode
TX Current	36 mA – Normal Mode; 42 mA Boost Mode
Crystal Frequency	24 MHz
Operating Temperature Range	-40 – +85 C
Voltage	(internal reg) 2.1 – 3.6 V
Package	6 mm x 6 mm 40 pin QFN

**RF Characteristics**

Data Rate	250 kbps
Frequency	2400 – 2500
RX Sensitivity	-99 dBm – Normal Mode; -100 dBm Boost Mode
Adj Channel Rejection (15.4)	>35 dB
Alt Channel Rejection (15.4)	>40 dB
802.11g Rejection (+12/-13 MHz)	>35 dB
TX Power	-32 dBm – +2.5 dBm Normal; -32 dBm – +4.5 dBm Boost



TECH-800-2420-0504  
Information contained in this document is subject to change without notice and is presented without express or implied warranty. Ember, EmberZNet and InSight are trademarks of Ember Corporation. All other trademarks are the property of their respective owners. Copyright 2010, Ember Corporation. All rights reserved.