

AMMC-6530

5–30 GHz Image Reject Mixer

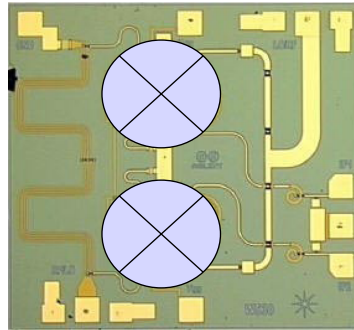

Data Sheet



Chip Size: 1300 x 1400 μm
 Chip Size Tolerance: $\pm 10 \mu\text{m}$ (± 0.4 mils)
 Chip Thickness: $100 \pm 10 \mu\text{m}$ (4 ± 0.4 mils)

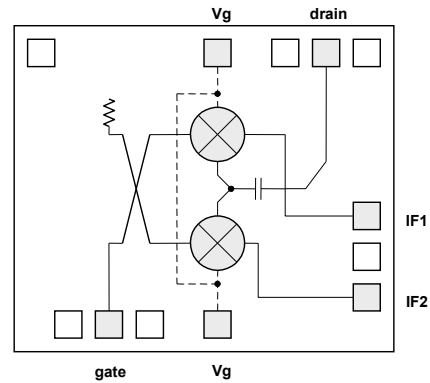

Description

Avago’s AMMC-6530 is an image reject mixer that operates from 5 to 30 GHz. The cold channel FET mixer is designed to be an easy-to-use component for any chip and wire application. It can be used drain pumped for low conversion loss applications, or when gate pumped the mixer can provide high linearity for SSB up-conversion. An external 90-degree hybrid is used to achieve image rejection and a -1V voltage reference is needed. Intended applications include microwave radios, 802.16, VSAT, and satellite receivers. Since this one mixer can cover several bands, the AMMC-6530 can reduce part inventory. The integrated mixer eliminates complex tuning and assembly processes typically required by hybrid (discrete-FET or diode) mixers. For improved reliability and moisture protection, the die is passivated at the active areas.

Features

- Broad Band Performance 5–30 GHz
- Low Conversion Loss of 8 dB
- High Image Rejection of 15–20 dB
- Good 3rd Order Intercept of +18 dBm
- Single -1V, no current Supply Bias

Applications

- Microwave Radio Systems
- Satellite VSAT, DBS Up/Down Link
- LMDS & Pt-Pt mmW Long Haul
- Broadband Wireless Access (including 802.16 and 802.20 WiMax)
- WLL and MMDS loops

Absolute Maximum Ratings^[1]

Symbol	Parameters/Conditions	Units	Min.	Max.
V_g	Gate Supply Voltage	V	0	-3
P_{in}	CW Input Power	dBm		25
T_{ch}	Operating Channel Temperature	$^{\circ}\text{C}$		+150
T_{stg}	Storage Case Temperature	$^{\circ}\text{C}$	-65	+150
T_{max}	Max. Assembly Temp (60 sec max)	$^{\circ}\text{C}$		+300

Note:

1. Operation in excess of any one of these conditions may result in permanent damage to this device.



Attention: Observe precautions for handling electrostatic sensitive devices.
 ESD Machine Model (Class A)
 ESD Human Body Model (Class 0)
 Refer to Avago Application Note A004R: Electrostatic Discharge Damage and Control.

AMMC-6530 DC Specifications/Physical Properties^[1]

Symbol	Parameters and Test Conditions	Units	Typ.
I_g	Gate Supply Current (under any RF power drive and temperature)	mA	0
V_g	Gate Supply Operating Voltage	V	-1V

Note:

1. Ambient operational temperature $T_A=25^\circ\text{C}$ unless otherwise noted.

AMMC-6530 Typical Performance^[2,3] ($T_A=25^\circ\text{C}$, $V_g=-1\text{V}$, IF frequency = 1 GHz, $Z_o=50\ \Omega$)

Symbol	Parameters and Test Conditions	Units	Gate Pumped	Drain Pumped	
F_{RF}	RF Frequency Range	GHz	5 – 30	5 – 30	
F_{LO}	LO Frequency Range	GHz	5 – 30	5 – 30	
F_{IF}	IF Frequency Range	GHz	DC – 5	DC – 5	
			Down Conversion	Up Conversion	
P_{LO}	LO Port Pumping Power	dBm	>10	>0	>10
CG	RF to IF Conversion Gain	dB	-10	-15	-8
RL_RF	RF Port Return Loss	dB	5	5	10
RL_LO	LO Port Return Loss	dB	10	10	5
RL_IF	IF Port Return Loss	dB	10	10	10
IR	Image Rejection Ratio	dB	15	15	15
LO-RF Iso.	LO to RF Port Isolation	dB	22	25	22
LO-IF Iso.	LO to IF Port Isolation	dB	25	25	25
RF-IF Iso.	RF to IF Port Isolation	dB	15	15	15
IIP3	Input IP3, $F_{\Delta}=100\ \text{MHz}$, $P_{rf} = -10\ \text{dBm}$, $P_{lo} = 15\ \text{dBm}$	dBm	18	—	10
P-1	Input Port Power at 1dB gain compression point, $P_{lo}=+10\ \text{dBm}$	dBm	8	—	0
NF	Noise Figure	dB	10	—	12

Notes:

2. Small/Large signal data measured in a fully de-embedded test fixture form $T_A = 25^\circ\text{C}$.
3. Specifications are derived from measurements in a 50 Ω test environment.

AMMC-6530 RF Specifications in Drain Pumped Test Configuration^[4, 5, 6]

($T_A=25^\circ\text{C}$, $V_g=-1.0\text{V}$, $P_{LO}=+10\ \text{dBm}$, $Z_o=50\ \Omega$)

Symbol	Parameters and Test Conditions	Units	Min	Typ.	Max
CG	Conversion Gain	$f = 7\ \text{GHz}$	dB	-12.0	-10.5
		$f = 18\ \text{GHz}$	dB	-10.0	-8.0
		$f = 28\ \text{GHz}$	dB	-12.5	-10.0
IR	Image Rejection Ratio	dB		-23.5	-18

Notes:

4. Performance verified 100% on-wafer.
5. 100% on-wafer RF testing is done at RF frequency = 7, 18, and 28 GHz; IF frequency = 2 GHz.
6. The external 90 degree hybrid coupler is from M/A-COM: PN 2032-6344-00. Frequency 1.0 – 2.0 GHz.

AMMC-6530 Typical Performance under Gate Pumped Down Conversion Operation

($T_A = 25^\circ\text{C}$, $V_g = -1\text{V}$, $Z_o = 50\Omega$)

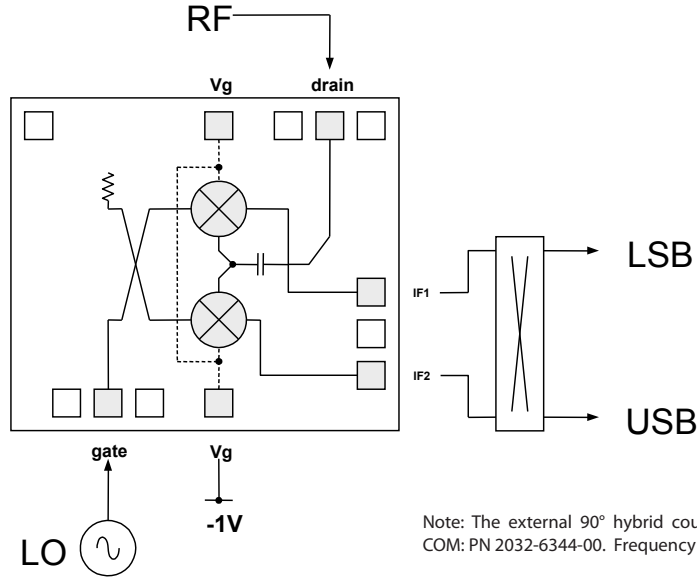

Note: The external 90° hybrid coupler is from M/A-COM: PN 2032-6344-00. Frequency is 1.0 – 2.0 GHz.

Highly linear down conversion or up conversion mixer application (Gate pumped mixer operation)

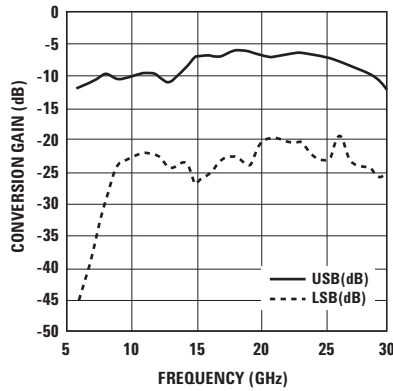

Figure 1. Conversion Gain with IF terminated for High Side Conversion
LO=+10 dBm, IF=1 GHz.

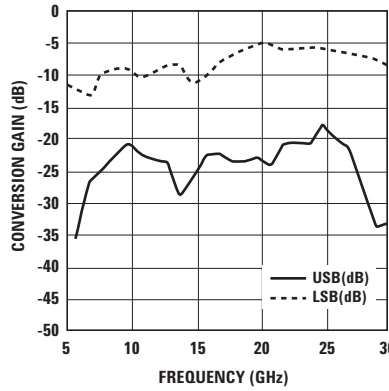

Figure 2. Conversion Gain with IF terminated for Low Side Conversion
LO=+10 dBm, IF=1 GHz.

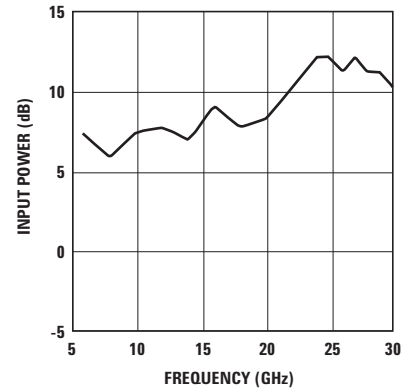

Figure 3. RF Port Input Power P-1dB.
LO=+10 dBm, IF=1 GHz.

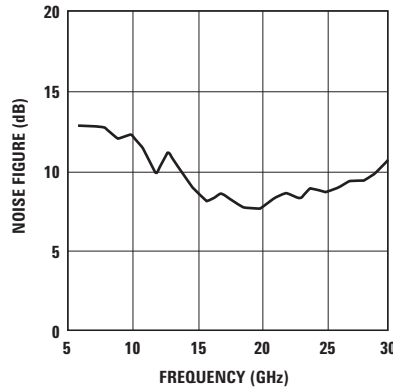

Figure 4. Noise Figure.
LO=+7 dBm, IF=1 GHz.

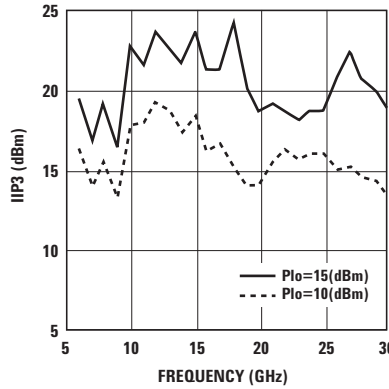

Figure 5. Input 3rd Order Intercept Point.
IF=1 GHz.

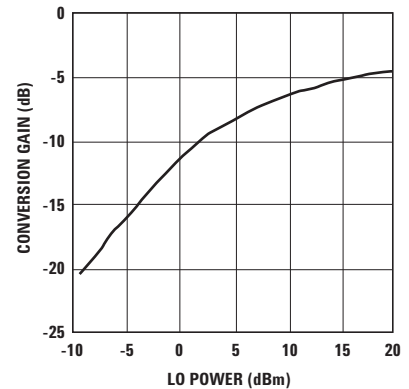

Figure 6. Conversion Gain vs. LO Power.
RF=21 GHz (-20 dBm), LO=20 GHz.

AMMC-6530 Typical Performance under Gate Pumped Down Conversion Operation

($T_A = 25^\circ\text{C}$, $V_g = -1\text{V}$, $Z_o = 50\Omega$)

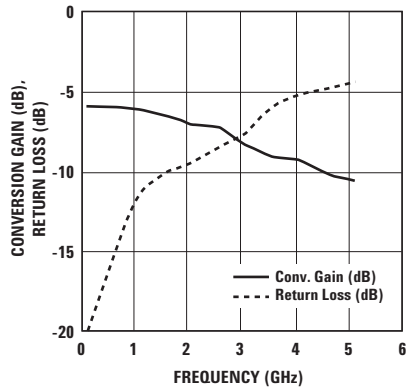

Figure 7. Conversion Gain and Match vs. IF Frequency. RF=20 GHz, LO=10 dBm.

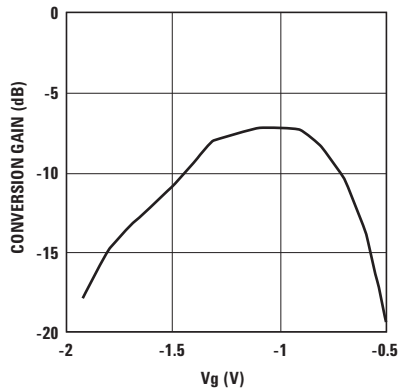

Figure 8. Conversion Gain vs. Gate Voltage. RF=20 GHz, LO=10 dBm.

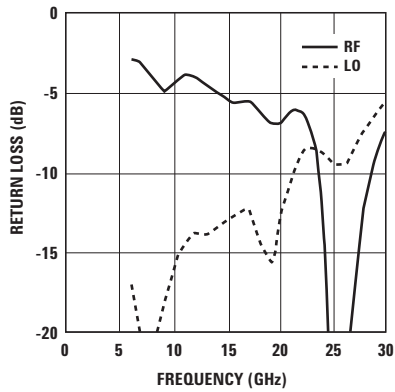

Figure 9. RF & LO Return Loss. LO=10 dBm.

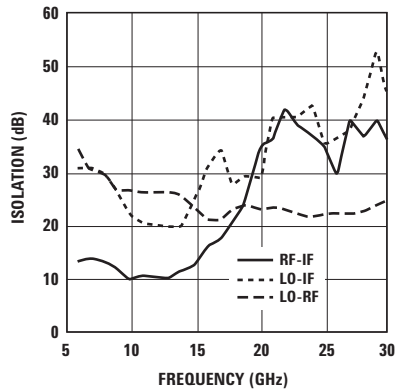

Figure 10. Isolation. LO=+10 dBm, IF=1 GHz.

AMMC-6530 Typical Performance under Gate Pumped Up Conversion Operation

($T_A = 25^\circ\text{C}$, $V_g = -1\text{V}$, $Z_o = 50\Omega$)

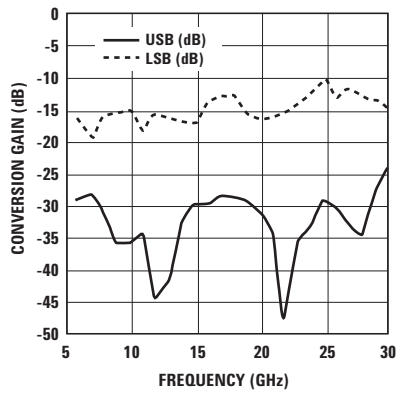
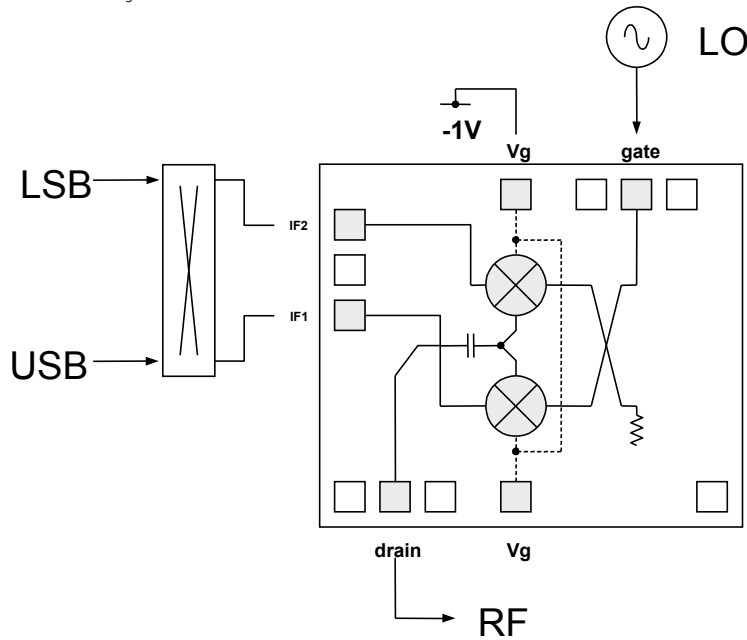

Figure 11. Up-conversion Gain with IF terminated for Low Side Conversion. LO=+5 dBm, IF=+5 dBm, IF=1 GHz.

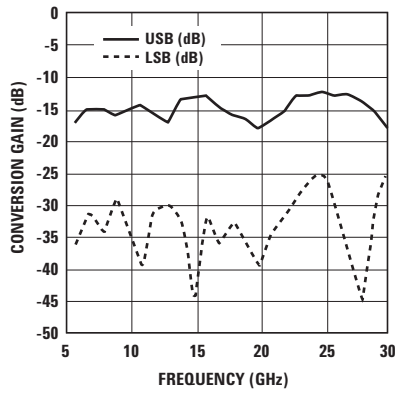

Figure 12. Up-conversion Gain with IF terminated for High Side Conversion. LO=+5 dBm, IF=+5 dBm, IF=1 GHz.

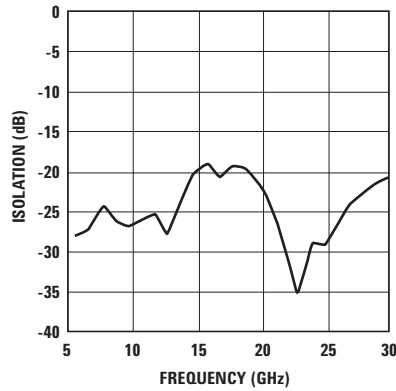

Figure 13. LO-RF Up-conversion Isolation.

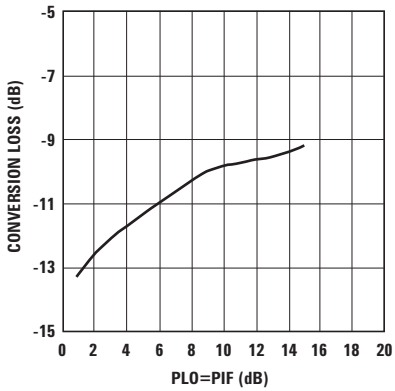
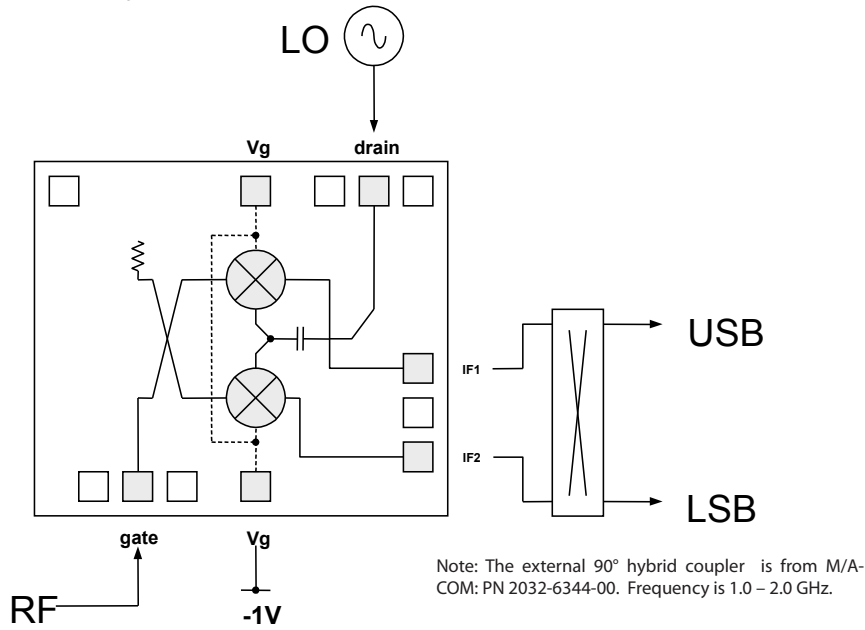

Figure 14. Up-conversion Gain vs. Pumping Power. LO power=IF power, IF=1 GHz, RF=25 GHz.

AMMC-6530 Typical Performance under Drain Pumped Down Conversion Operation

($T_A = 25^\circ\text{C}$, $V_g = -1\text{V}$, $Z_o = 50\Omega$)



Low conversion loss mixer configuration (Drain pumped mixer operation)

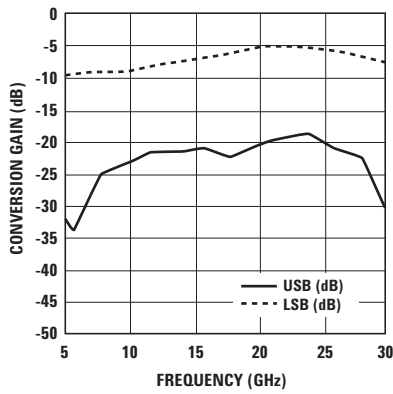

Figure 15. Conversion Gain with IF terminated for Low Side Conversion. LO=+10 dBm, IF=1 GHz.

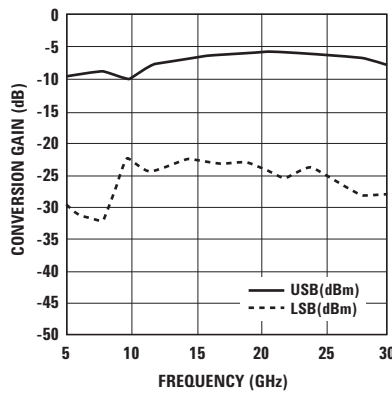

Figure 16. Conversion Gain with IF terminated for High Side Conversion. LO=+10 dBm, IF=1 GHz.

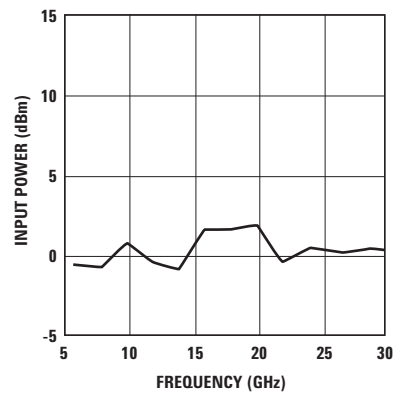

Figure 17. RF Port Input Power P-1dB. LO=+10 dBm, IF=1 GHz.

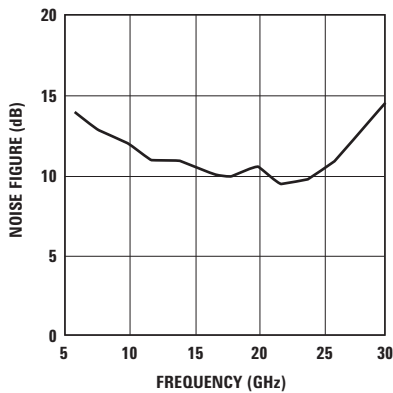

Figure 18. Noise Figure. LO=+7 dBm, IF=1 GHz.

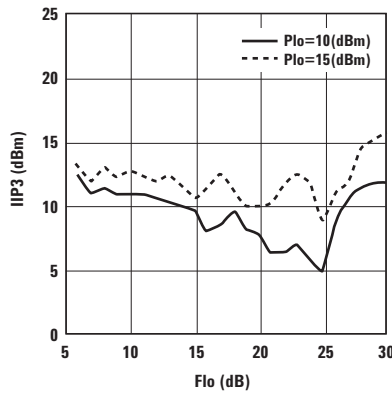

Figure 19. Input 3rd Order Intercept Point. IF=1 GHz.

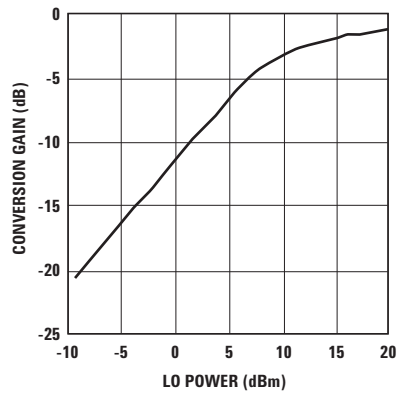

Figure 20. Conversion Gain vs. LO power. RF=21 GHz (-20 dBm), LO=20 GHz.

Biasing and Operation

The recommended DC bias condition for optimum performance, and reliability is $V_g = -1$ volts. This can be applied to either of the two V_g connections as they are internally connected. There is no current consumption for the gate biasing because the FET mixer was designed for passive operation. For down conversion, the AMMC-6530 may be configured in a low loss or high linearity application. In a low loss configuration, the LO is applied through the drain. In this configuration, the AMMC-6530 is a "drain pumped mixer". For higher linearity applications, the LO is applied through the gate. In this configuration, the AMMC-6530 is a "gate pumped mixer" (or Resistive mixer). The mixer is also suitable for up-conversion applications under the gate pumped mixer operation shown on page 5.

Please note that the image rejection and isolation performance is dependent on the selection of the low frequency quadrature hybrid. The performance specification of the low frequency quadrature hybrid as well as the phase balance and VSWR of the interface to the AMMC-6530 will affect the overall mixer performance.

Assembly Techniques

The backside of the MMIC chip is RF ground. For microstrip applications the chip should be attached directly to the ground plane (e.g. circuit carrier or heatsink) using electrically conductive epoxy^[1,2].

For best performance, the topside of the MMIC should be brought up to the same height as the circuit surrounding it. This can be accomplished by mounting a gold plate metal shim (same length and width as the MMIC) under the chip which is of correct thickness to make the chip and adjacent circuit the same height. The amount of epoxy used for the chip and/or shim attachment should be just enough to provide a thin fillet around the bottom perimeter of the chip or shim. The ground plane should be free of any residue that may jeopardize electrical or mechanical attachment.

The location of the RF bond pads is shown in Figure

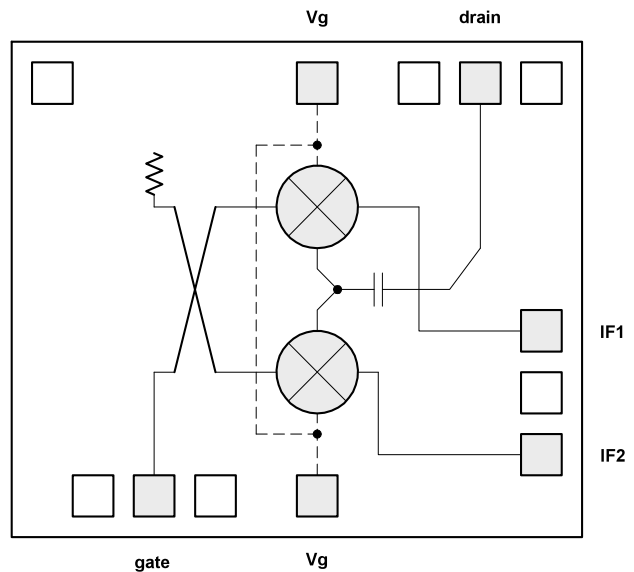

Figure 21. Simplified MMIC Schematic.

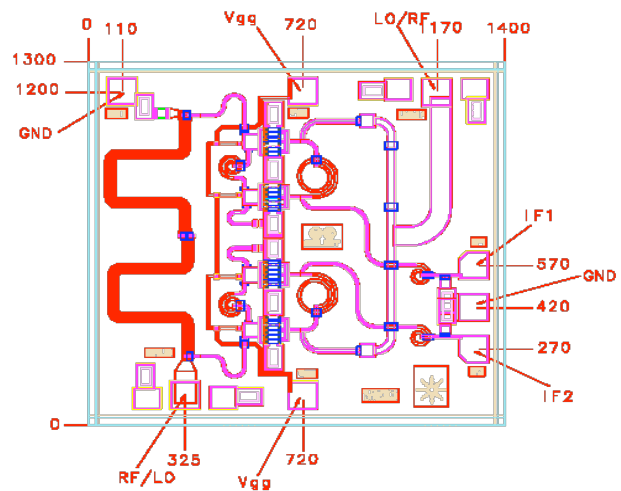

Figure 22. AMMC-6530 Bond Pad locations.

23. Note that all the RF input and output ports are in a Ground-Signal-Ground configuration.

RF connections should be kept as short as reasonable to minimize performance degradation due to undesirable series inductance. A single bond wire is normally sufficient for signal connections, however double bonding with 0.7 mil gold wire or use of gold mesh is recommended for best performance, especially near the high end of the frequency band. Thermosonic wedge bonding is the preferred method for wire attachment to the bond pads.

Gold mesh can be attached using a 2 mil round tracking tool and a tool force of approximately 22 grams and a ultrasonic power of roughly 55 dB for a duration of 76 ± 8 mS. The guided wedge at an ultrasonic power level of 64 dB can be used for 0.7 mil wire. The recommended wire bond stage temperature is $150 \pm 2^\circ\text{C}$. Caution should be taken to not exceed the Absolute Maximum Rating for assembly temperature and time.

The chip is 100 μm thick and should be handled with care.

This MMIC has exposed air bridges on the top surface and should be handled by the edges or with a custom collet (do not pick up the die with a vacuum on die center).

This MMIC is also static sensitive and ESD precautions should be taken.

Notes:

1. Ablebond 84-1 LM1 silver epoxy is recommended.
2. Eutectic attach is not recommended and may jeopardize reliability of the device.

Part Number Ordering Information

Part Number	Devices per Container
AMMC-6530-W10	10
AMMC-6530-W50	50

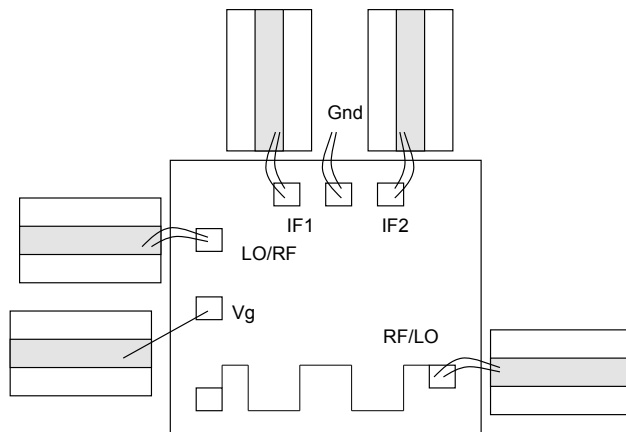

Figure 23. AMMC-6530 Assembly Diagram.

For product information and a complete list of distributors, please go to our web site:

www.avagotech.com

Avago, Avago Technologies, and the A logo are trademarks of Avago Technologies in the United States and other countries. Data subject to change. Copyright © 2005-2008 Avago Technologies. All rights reserved. Obsoletes 5989-3945EN AV02-1293EN - July 30, 2008

