

AMMC-5026

2–35 GHz GaAs MMIC Traveling Wave Amplifier

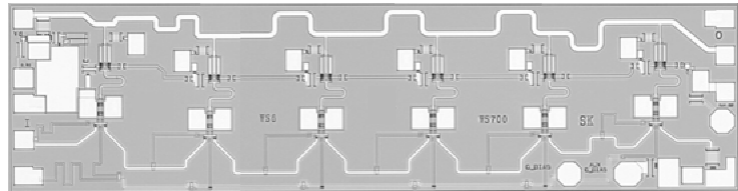

Data Sheet



Chip Size: 3050 x 840 μm (119 x 33 mils)
Chip Size Tolerance: $\pm 10 \mu\text{m}$ (± 0.4 mils)
Chip Thickness: $100 \pm 10 \mu\text{m}$ (4 ± 0.4 mils)
Pad Dimensions: $75 \times 75 \mu\text{m}$ (2.9 ± 0.4 mils)

Description

The AMMC-5026 is a broadband PHEMT GaAs MMIC Traveling Wave Amplifier (TWA) designed for medium output power and high gain over the full 2 GHz to 35 GHz frequency range. The design employs a 6-section cascode connected FET structure to provide flat gain and medium power as well as uniform group delay. For improved reliability and moisture protection, the die is passivated at the active areas.

Applications

- Broadband gain block
- Broadband driver amplifier
- 10 Gb/s Fiber Optics

Features

- Frequency range: 2–35 GHz
- Gain: 10.5 dB
- Gain flatness: ± 0.8 dB
- Return loss:
Input 17 dB, Output: 15 dB
- Output power (P-1dB):
24 dBm at 10 GHz
23 dBm at 20 GHz
22 dBm at 26 GHz
- Noise figure (6–19 GHz): ≤ 4 dB

Absolute Maximum Ratings^[1]

| Symbol | Parameters/Conditions | Units | Min. | Max. |
|-----------|---------------------------------|--------------------|------|------|
| V_{dd} | Positive Drain Voltage | V | | 10 |
| I_{dd} | Total Drain Current | mA | | 450 |
| V_{g1} | First Gate Voltage | V | -5 | |
| I_{g1} | First Gate Current | mA | -9 | +5 |
| V_{g2} | Second Gate Voltage | V | -3 | +3.5 |
| I_{g2} | Second Gate Current | mA | -10 | |
| P_{in} | CW Input Power | dBm | | 23 |
| T_{ch} | Channel Temperature | $^{\circ}\text{C}$ | | +150 |
| T_b | Operating Backside Temperature | $^{\circ}\text{C}$ | -55 | |
| T_{stg} | Storage Temperature | $^{\circ}\text{C}$ | -65 | +165 |
| T_{max} | Max. Assembly Temp (60 sec max) | $^{\circ}\text{C}$ | | +300 |

Notes:

1. Operation in excess of any one of these conditions may result in permanent damage to this device.

AMMC-5026 DC Specifications/Physical Properties^[1]

| Symbol | Parameters and Test Conditions | Units | Min. | Typ. | Max. |
|-----------------------------|--|--------------------|------|------|------|
| I_{dss} | Saturated Drain Current ($V_{dd}=7V, V_{g1}=0V, V_{g2}=\text{open circuit}$) | mA | 250 | 350 | 450 |
| V_{p1} | First Gate Pinch-off Voltage ($V_{dd}=7V, I_{dd}=0.1 I_{dss}, V_{g2}=\text{open circuit}$) | V | | -1.2 | |
| V_{g2} | Second Gate Self-bias Voltage ($V_{dd}=7V, I_{dd}=150\text{ mA}, V_{g2}=\text{open circuit}$) | V | | 3.5 | |
| I_{dsoff} (V_{g1}) | First Gate Pinch-off Current ($V_{dd}=7V, V_{g1}=3.5V, V_{g2}=\text{open circuit}$) | mA | | 75 | |
| θ_{ch-b} | Thermal Resistance ^[2] (Backside temperature, $T_b = 25^\circ\text{C}$) | $^\circ\text{C/W}$ | | 28 | |

Notes:

1. Backside temperature $T_b = 25^\circ\text{C}$ unless otherwise noted.
2. Channel-to-backside Thermal Resistance (θ_{ch-b}) = 38°C/W at $T_{channel}(T_c) = 150^\circ\text{C}$ as measured using the liquid crystal method. Thermal Resistance at backside temperature (T_b) = 25°C calculated from measured data.

RF Specifications^[3,4]

($V_{dd} = 7V, I_{dd}(Q) = 150\text{ mA}, Z_{in} = Z_0 = 50\Omega$)

| Symbol | Parameters and Test Conditions | Units | Min. | Typ. | Max. |
|--------------------|---|--|------|------------|-----------|
| $ S_{21} ^2$ | Small-signal Gain | dB | 8.5 | 10.5 | 12.5 |
| $\Delta S_{21} ^2$ | Small-signal Gain Flatness | dB | | ± 0.75 | ± 1.5 |
| RL_{in} | Input Return Loss | dB | 13 | 17 | |
| RL_{out} | Output Return Loss | dB | 12 | 15 | |
| $ S_{12} ^2$ | Isolation | dB | 23 | 26 | |
| P_{-1dB} | Output Power @ 1 dB Gain Compression | $f = 10\text{ GHz}$ dBm | 22 | 24 | |
| P_{sat} | Saturated Output Power | $f = 10\text{ GHz}$ dBm | | 26 | |
| OIP3 | Output 3 rd Order Intercept Point, $RF_{in1} = RF_{in2} = -20\text{ dBm}, f = 10\text{ GHz}, \Delta f = 2\text{ MHz}$ | dBm | | 31 | |
| NF | Noise Figure | $f = 10\text{ GHz}$ dB $f = 20\text{ GHz}$ dB | | 3.6 4.3 | |
| H2 | Second Harmonic ($P_{in} = 12\text{ dBm}$ at 10 GHz) | dBc | | -20 | -17.5 |
| H3 | Third Harmonic ($P_{in} = 12\text{ dBm}$ at 10 GHz) | dBc | | -30 | -28 |

Notes:

1. Data measured in wafer form, $T_{chuck} = 25^\circ\text{C}$.
2. 100% on wafer RF test is done at frequency = 2, 10, 22, 26.5, and 35 GHz, except as noted.

AMMC-5026 Typical Performance

($T_{\text{chuck}} = 25^{\circ}\text{C}$, $V_{\text{dd}} = 7\text{V}$, $I_{\text{dd}} = 150\text{ mA}$, $V_{\text{g2}} = \text{Open}$, $Z_0 = 50\Omega$)

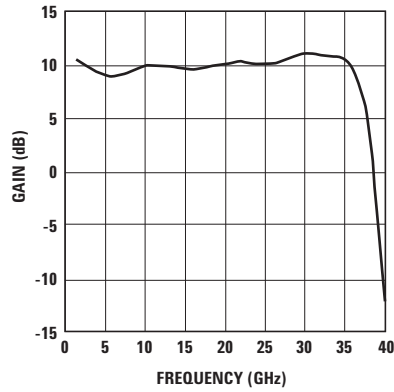

Figure 1. Gain.

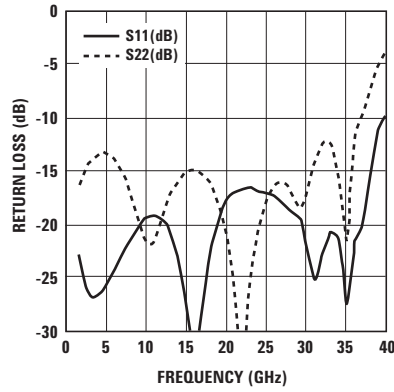

Figure 2. Input and Output Return Loss.

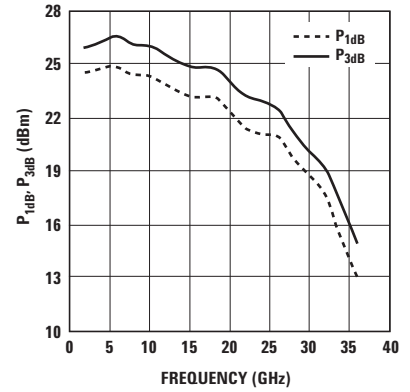

Figure 3. Output Power at $P_{1\text{dB}}$ and $P_{3\text{dB}}$.

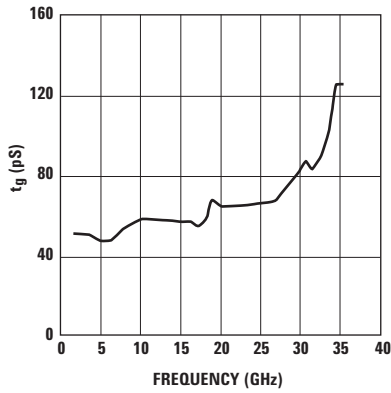

Figure 4. Group Delay.

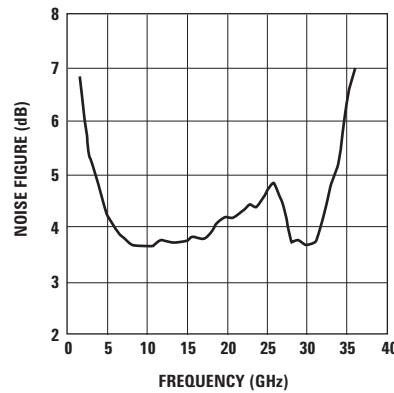

Figure 5. Noise Figure.

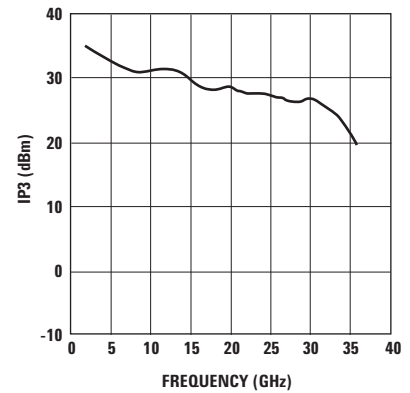

Figure 6. Output 3rd Order Intercept Point.

AMMC-5026 Typical Performance

($T_{\text{chuck}} = 25^{\circ}\text{C}$, $V_{\text{dd}} = 8\text{V}$, $I_{\text{dd}} = 150\text{mA}$, $V_{\text{g2}} = \text{Open}$, $Z_0 = 50\Omega$)

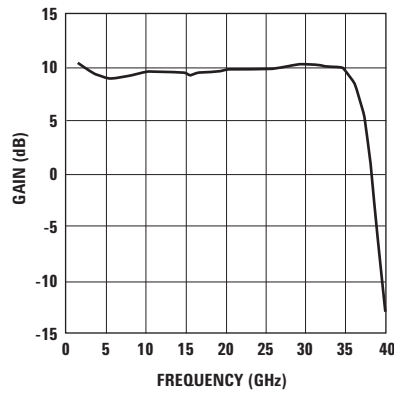

Figure 7. Gain.

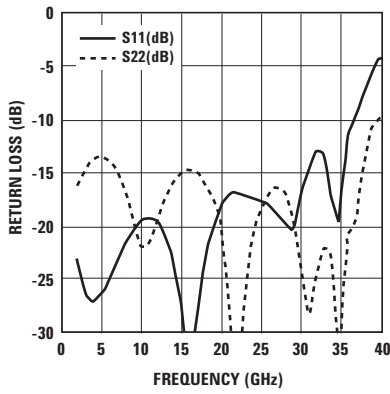

Figure 8. Input and Output Return Loss.

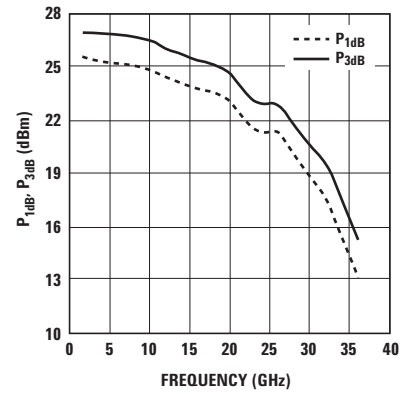

Figure 9. Output Power at $P_{1\text{dB}}$ and $P_{3\text{dB}}$.

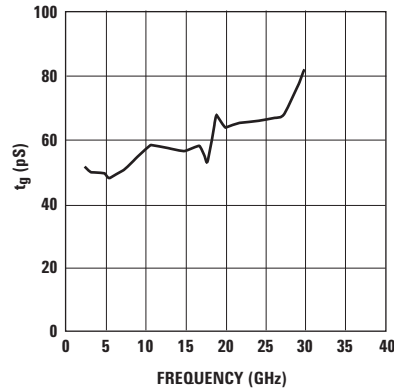

Figure 10. Group Delay.

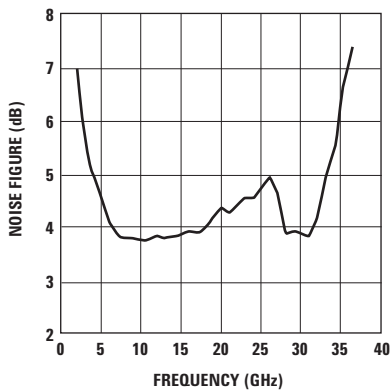

Figure 11. Noise Figure.

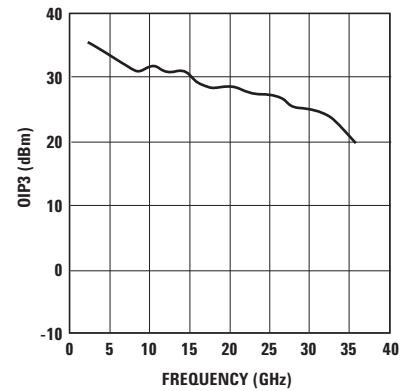

Figure 12. Output 3rd Order Intercept Point.

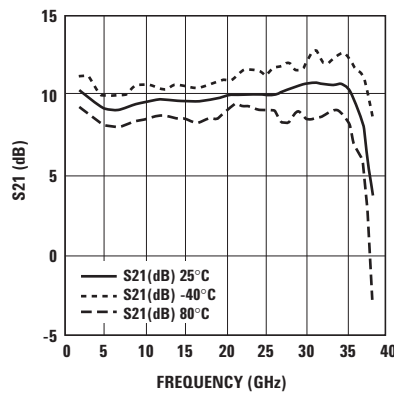

Figure 13. Gain vs. Temperature.

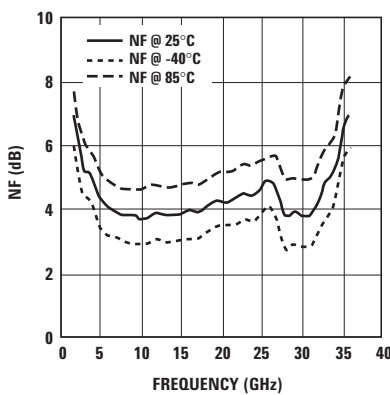

Figure 14. Noise Figure vs. Temperature.

AMMC-5026 Typical Scattering Parameters^[1]

($T_{\text{chuck}} = 25^{\circ}\text{C}$, $V_{\text{dd}} = 7\text{V}$, $I_{\text{dd}} = 150\text{ mA}$)

| Freq. GHz | S_{11} | | | S_{21} | | | S_{12} | | | S_{22} | | |
|--------------|----------|------|------|----------|------|------|----------|--------|------|----------|------|------|
| | dB | Mag | Ang | dB | Mag | Ang | dB | Mag | Ang | dB | Mag | Ang |
| 2.0 | -24.93 | 0.06 | -56 | 9.89 | 3.12 | 130 | -52.04 | 0.0025 | -109 | -17.16 | 0.14 | -126 |
| 3.0 | -26.84 | 0.05 | -18 | 9.50 | 2.98 | 112 | -48.40 | 0.0038 | -131 | -15.78 | 0.16 | -154 |
| 4.0 | -25.16 | 0.06 | -2 | 9.14 | 2.87 | 94 | -45.19 | 0.0055 | -154 | -14.87 | 0.18 | 179 |
| 5.0 | -23.72 | 0.07 | 2 | 8.90 | 2.79 | 77 | -43.10 | 0.0070 | -174 | -14.55 | 0.19 | 154 |
| 6.0 | -22.99 | 0.07 | 2 | 8.81 | 2.76 | 60 | -41.31 | 0.0086 | 164 | -14.82 | 0.18 | 128 |
| 7.0 | -22.58 | 0.07 | 1 | 8.87 | 2.78 | 42 | -40.00 | 0.0100 | 143 | -15.68 | 0.16 | 101 |
| 8.0 | -21.97 | 0.08 | 1 | 9.04 | 2.83 | 24 | -38.94 | 0.0113 | 122 | -17.22 | 0.14 | 73 |
| 9.0 | -21.29 | 0.09 | -3 | 9.24 | 2.90 | 5 | -38.13 | 0.0124 | 103 | -19.41 | 0.11 | 39 |
| 10.0 | -20.67 | 0.09 | -7 | 9.42 | 2.96 | -15 | -37.33 | 0.0136 | 84 | -21.84 | 0.08 | -6 |
| 11.0 | -20.29 | 0.10 | -16 | 9.53 | 2.99 | -35 | -36.65 | 0.0147 | 66 | -22.43 | 0.08 | -62 |
| 12.0 | -20.47 | 0.09 | -29 | 9.56 | 3.01 | -56 | -36.03 | 0.0158 | 49 | -20.48 | 0.09 | -110 |
| 13.0 | -21.49 | 0.08 | -43 | 9.52 | 2.99 | -76 | -35.34 | 0.0171 | 32 | -18.32 | 0.12 | -145 |
| 14.0 | -23.65 | 0.07 | -59 | 9.46 | 2.97 | -97 | -34.61 | 0.0186 | 14 | -16.78 | 0.14 | -172 |
| 15.0 | -28.02 | 0.04 | -81 | 9.40 | 2.95 | -117 | -33.89 | 0.0202 | -3 | -15.83 | 0.16 | 165 |
| 16.0 | -39.49 | 0.01 | -131 | 9.36 | 2.94 | -137 | -32.96 | 0.0225 | -22 | -15.57 | 0.17 | 144 |
| 17.0 | -31.18 | 0.03 | 86 | 9.41 | 2.95 | -157 | -32.22 | 0.0245 | -41 | -15.93 | 0.16 | 125 |
| 18.0 | -24.21 | 0.06 | 60 | 9.52 | 2.99 | -177 | -31.57 | 0.0264 | -62 | -16.86 | 0.14 | 107 |
| 19.0 | -20.93 | 0.09 | 38 | 9.68 | 3.05 | 162 | -30.96 | 0.0283 | -82 | -18.63 | 0.12 | 91 |
| 20.0 | -18.20 | 0.12 | 13 | 9.79 | 3.09 | 141 | -30.60 | 0.0295 | -104 | -21.67 | 0.08 | 78 |
| 21.0 | -17.48 | 0.13 | -17 | 9.94 | 3.14 | 119 | -30.17 | 0.0310 | -125 | -27.56 | 0.04 | 74 |
| 22.0 | -17.43 | 0.13 | -46 | 10.02 | 3.17 | 96 | -29.90 | 0.0320 | -147 | -32.88 | 0.02 | 142 |
| 23.0 | -17.77 | 0.13 | -81 | 10.07 | 3.19 | 73 | -29.74 | 0.0326 | -168 | -24.55 | 0.06 | 171 |
| 24.0 | -18.27 | 0.12 | -119 | 10.06 | 3.18 | 50 | -29.50 | 0.0335 | 171 | -19.79 | 0.10 | 163 |
| 25.0 | -18.66 | 0.12 | -161 | 10.04 | 3.18 | 27 | -29.24 | 0.0345 | 150 | -17.19 | 0.14 | 150 |
| 26.0 | -18.56 | 0.12 | 156 | 10.08 | 3.19 | 4 | -28.85 | 0.0361 | 129 | -15.72 | 0.16 | 135 |
| 27.0 | -18.60 | 0.12 | 112 | 10.20 | 3.24 | -19 | -28.34 | 0.0383 | 107 | -15.10 | 0.18 | 119 |
| 28.0 | -19.07 | 0.11 | 66 | 10.46 | 3.33 | -44 | -27.70 | 0.0412 | 83 | -15.28 | 0.17 | 104 |
| 29.0 | -19.79 | 0.10 | 9 | 10.75 | 3.45 | -70 | -27.23 | 0.0435 | 57 | -16.61 | 0.15 | 89 |
| 30.0 | -18.63 | 0.12 | -59 | 10.99 | 3.54 | -98 | -26.80 | 0.0457 | 29 | -19.73 | 0.10 | 80 |
| 31.0 | -15.62 | 0.17 | -116 | 11.07 | 3.58 | -127 | -26.67 | 0.0464 | 0 | -24.26 | 0.06 | 102 |
| 32.0 | -13.40 | 0.21 | -161 | 10.93 | 3.52 | -158 | -26.82 | 0.0456 | -29 | -21.06 | 0.09 | 136 |
| 33.0 | -12.69 | 0.23 | 161 | 10.79 | 3.46 | 171 | -26.97 | 0.0448 | -58 | -17.40 | 0.13 | 133 |
| 34.0 | -14.73 | 0.18 | 127 | 10.78 | 3.46 | 139 | -26.96 | 0.0449 | -89 | -15.99 | 0.16 | 118 |
| 35.0 | -26.00 | 0.05 | 120 | 10.83 | 3.48 | 102 | -26.76 | 0.0459 | -125 | -17.25 | 0.14 | 107 |
| 36.0 | -14.82 | 0.18 | -157 | 10.24 | 3.25 | 58 | -27.23 | 0.0435 | -169 | -18.78 | 0.12 | 120 |
| 37.0 | -10.01 | 0.32 | 172 | 8.79 | 2.75 | 12 | -28.38 | 0.0381 | 146 | -16.58 | 0.15 | 125 |
| 38.0 | -9.81 | 0.32 | 161 | 6.12 | 2.02 | -42 | -30.66 | 0.0293 | 91 | -18.73 | 0.12 | 125 |
| 39.0 | -6.40 | 0.48 | 157 | -0.65 | 0.93 | -90 | -36.71 | 0.0146 | 44 | -13.68 | 0.21 | 154 |
| 40.0 | -4.23 | 0.61 | 135 | -7.76 | 0.41 | -109 | -42.85 | 0.0072 | 18 | -10.52 | 0.30 | 139 |

Note:

1. Data obtained from on-wafer measurements.

AMMC-5026 Typical Scattering Parameters^[1]

($T_{\text{chuck}} = 25^{\circ}\text{C}$, $V_{\text{dd}} = 8\text{V}$, $I_{\text{dd}} = 150\text{mA}$)

| Freq. GHz | S_{11} | | | S_{21} | | | S_{12} | | | S_{22} | | |
|--------------|----------|------|------|----------|------|------|----------|--------|------|----------|------|------|
| | dB | Mag | Ang | dB | Mag | Ang | dB | Mag | Ang | dB | Mag | Ang |
| 2.0 | -24.88 | 0.06 | -57 | 9.59 | 3.02 | 129 | -51.70 | 0.0026 | -109 | -17.27 | 0.14 | -123 |
| 3.0 | -26.86 | 0.05 | -19 | 9.20 | 2.88 | 112 | -47.74 | 0.0041 | -131 | -15.97 | 0.16 | -152 |
| 4.0 | -25.30 | 0.05 | -2 | 8.85 | 2.77 | 94 | -45.04 | 0.0056 | -153 | -15.10 | 0.18 | -179 |
| 5.0 | -23.94 | 0.06 | 2 | 8.59 | 2.69 | 76 | -42.85 | 0.0072 | -175 | -14.79 | 0.18 | 155 |
| 6.0 | -23.17 | 0.07 | 2 | 8.49 | 2.66 | 59 | -41.11 | 0.0088 | 164 | -15.05 | 0.18 | 129 |
| 7.0 | -22.72 | 0.07 | 1 | 8.54 | 2.67 | 41 | -39.74 | 0.0103 | 144 | -15.89 | 0.16 | 102 |
| 8.0 | -22.09 | 0.08 | 1 | 8.70 | 2.72 | 23 | -38.56 | 0.0118 | 123 | -17.37 | 0.14 | 72 |
| 9.0 | -21.42 | 0.08 | -3 | 8.89 | 2.78 | 4 | -37.72 | 0.0130 | 104 | -19.46 | 0.11 | 38 |
| 10.0 | -20.79 | 0.09 | -7 | 9.07 | 2.84 | -16 | -37.02 | 0.0141 | 85 | -21.68 | 0.08 | -7 |
| 11.0 | -20.42 | 0.10 | -17 | 9.17 | 2.87 | -37 | -36.31 | 0.0153 | 67 | -22.16 | 0.08 | -61 |
| 12.0 | -20.68 | 0.09 | -30 | 9.20 | 2.88 | -58 | -35.60 | 0.0166 | 49 | -20.38 | 0.10 | -108 |
| 13.0 | -21.76 | 0.08 | -44 | 9.15 | 2.87 | -78 | -34.94 | 0.0179 | 32 | -18.33 | 0.12 | -143 |
| 14.0 | -24.04 | 0.06 | -61 | 9.08 | 2.84 | -99 | -34.20 | 0.0195 | 14 | -16.84 | 0.14 | -171 |
| 15.0 | -28.68 | 0.04 | -83 | 9.01 | 2.82 | -119 | -33.47 | 0.0212 | -3 | -15.91 | 0.16 | 166 |
| 16.0 | -40.72 | 0.01 | -151 | 8.97 | 2.81 | -139 | -32.62 | 0.0234 | -21 | -15.67 | 0.16 | 145 |
| 17.0 | -30.52 | 0.03 | 86 | 9.00 | 2.82 | -159 | -31.87 | 0.0255 | -41 | -16.02 | 0.16 | 125 |
| 18.0 | -24.07 | 0.06 | 58 | 9.11 | 2.85 | -180 | -31.28 | 0.0273 | -61 | -16.95 | 0.14 | 107 |
| 19.0 | -21.00 | 0.09 | 36 | 9.26 | 2.90 | 159 | -30.66 | 0.0293 | -81 | -18.70 | 0.12 | 91 |
| 20.0 | -18.37 | 0.12 | 12 | 9.35 | 2.93 | 137 | -30.26 | 0.0307 | -103 | -21.76 | 0.08 | 77 |
| 21.0 | -17.78 | 0.13 | -18 | 9.49 | 2.98 | 115 | -29.87 | 0.0321 | -124 | -27.81 | 0.04 | 69 |
| 22.0 | -17.89 | 0.13 | -49 | 9.57 | 3.01 | 93 | -29.53 | 0.0334 | -146 | -34.56 | 0.02 | 146 |
| 23.0 | -18.34 | 0.12 | -84 | 9.60 | 3.02 | 70 | -29.42 | 0.0338 | -168 | -24.90 | 0.06 | 175 |
| 24.0 | -18.89 | 0.11 | -123 | 9.57 | 3.01 | 46 | -29.17 | 0.0348 | 172 | -19.97 | 0.10 | 165 |
| 25.0 | -19.20 | 0.11 | -166 | 9.53 | 3.00 | 23 | -28.95 | 0.0357 | 151 | -17.32 | 0.14 | 151 |
| 26.0 | -19.05 | 0.11 | 151 | 9.55 | 3.00 | 0 | -28.57 | 0.0373 | 130 | -15.83 | 0.16 | 136 |
| 27.0 | -19.12 | 0.11 | 108 | 9.65 | 3.04 | -24 | -28.09 | 0.0394 | 108 | -15.23 | 0.17 | 120 |
| 28.0 | -19.87 | 0.10 | 62 | 9.88 | 3.12 | -49 | -27.47 | 0.0423 | 84 | -15.44 | 0.17 | 105 |
| 29.0 | -20.78 | 0.09 | 3 | 10.14 | 3.21 | -75 | -27.05 | 0.0444 | 58 | -16.82 | 0.14 | 90 |
| 30.0 | -19.42 | 0.11 | -67 | 10.33 | 3.29 | -103 | -26.69 | 0.0463 | 30 | -20.01 | 0.10 | 81 |
| 31.0 | -16.18 | 0.16 | -123 | 10.37 | 3.30 | -133 | -26.60 | 0.0468 | 1 | -24.45 | 0.06 | 103 |
| 32.0 | -13.92 | 0.20 | -166 | 10.21 | 3.24 | -164 | -26.76 | 0.0459 | -28 | -21.24 | 0.09 | 136 |
| 33.0 | -13.31 | 0.22 | 158 | 10.03 | 3.17 | 165 | -26.92 | 0.0451 | -57 | -17.71 | 0.13 | 133 |
| 34.0 | -15.52 | 0.17 | 129 | 9.95 | 3.14 | 132 | -26.97 | 0.0448 | -88 | -16.44 | 0.15 | 119 |
| 35.0 | -23.72 | 0.07 | 144 | 9.82 | 3.10 | 95 | -27.01 | 0.0446 | -124 | -17.71 | 0.13 | 111 |
| 36.0 | -14.68 | 0.18 | -169 | 9.06 | 2.84 | 52 | -27.64 | 0.0415 | -167 | -18.68 | 0.12 | 123 |
| 37.0 | -10.47 | 0.30 | 166 | 7.43 | 2.35 | 6 | -29.02 | 0.0354 | 148 | -16.97 | 0.14 | 127 |
| 38.0 | -9.72 | 0.33 | 159 | 4.27 | 1.64 | -46 | -31.77 | 0.0258 | 96 | -18.00 | 0.13 | 136 |
| 39.0 | -6.77 | 0.46 | 152 | -2.02 | 0.79 | -88 | -37.46 | 0.0134 | 53 | -13.26 | 0.22 | 151 |
| 40.0 | -4.70 | 0.58 | 133 | -8.14 | 0.39 | -108 | -42.97 | 0.0071 | 28 | -10.51 | 0.30 | 138 |

Note:

1. Data obtained from on-wafer measurements.

Biasing and Operation

AMMC-5026 is biased with a single positive drain supply (V_d) and a negative gate supply (V_{g1}). The recommended bias conditions for the AMMC-5026 is $V_{dd} = 7V$ and $I_{dd} = 150\text{ mA}$ for best overall performance. Open circuit is the default setting for the V_{g2} biasing.

Figure 17 shows a typical bonding configuration for the 2 to 35 GHz operations. In this case, auxiliary drain and V_{g1} capacitors ($>0.5\ \mu\text{F}$) are used for low frequency (below 2 GHz) performance. Input and output RF ports are DC coupled; therefore, DC decoupling capacitors are required if there are DC paths.

The auxiliary gate and drain contacts are used for low frequency performance extension below 1 GHz. When used, these contacts must be AC coupled only. (Do not attempt to apply bias to these pads.)

Ground connections are made with plated through-holes to the backside of the device.

Assembly Techniques

The backside of the MMIC chip is RF ground. For microstrip applications the chip should be attached directly to the ground plane (e.g. circuit carrier or heatsink) using electrically conductive epoxy^[1,2]. For conductive epoxy, the amount should be just enough to provide a thin fillet around the bottom perimeter of the die. The ground plane should be free of any residue that may jeopardize electrical or mechanical attachment. Caution should be taken to not exceed the Absolute Maximum Rating for assembly temperature and time.

Thermosonic wedge bonding is the preferred method for wire attachment to the bond pads. The RF connections should be kept as short as possible to minimize inductance. Gold mesh or double-bonding with 0.7 mil gold wire is recommended.

Mesh can be attached using a 2 mil round tracking tool and a tool force of approximately 22 grams with an ultrasonic power of roughly 55 dB for a duration of $76 \pm 8\text{ mS}$. A guided wedge at an ultrasonic power level of 64 dB can be used for the 0.7 mil wire. The recommended wire bond stage temperature is $150 \pm 2^\circ\text{C}$.

The chip is 100 mm thick and should be handled with care.

This MMIC has exposed air bridges on the top surface. Handle at edges or with a custom collet (do not pick up die with vacuum on die center.)

This MMIC is also static sensitive and ESD handling precautions should be taken.

Notes:

1. Ablebond 84-1 LM1 silver epoxy is recommended.
2. Eutectic attach is not recommended and may jeopardize reliability of the device.

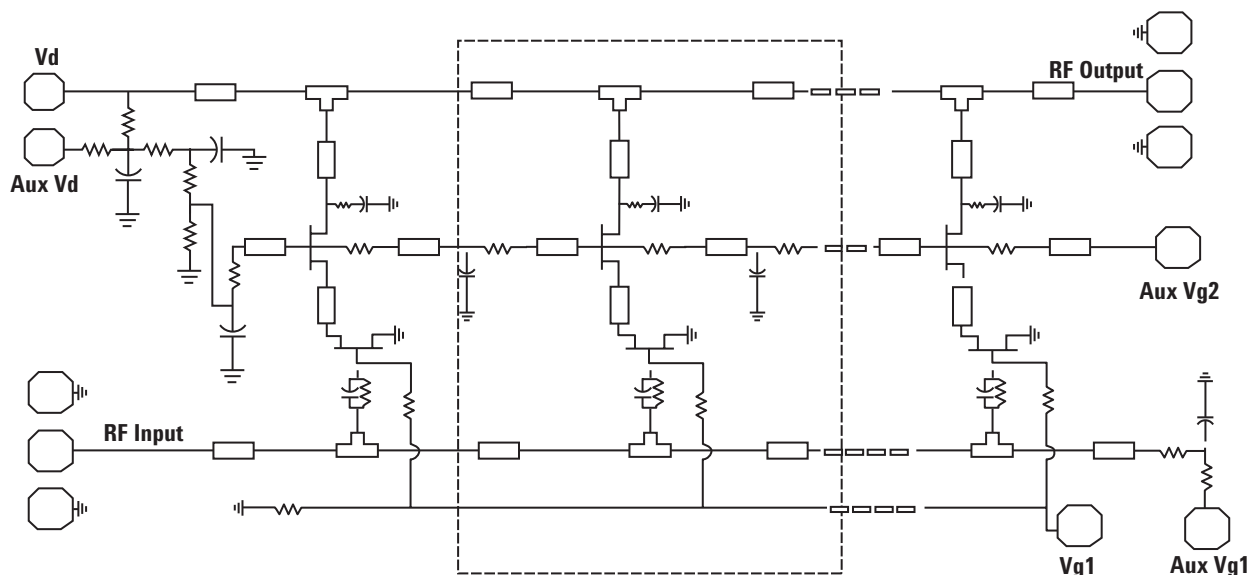

Figure 15. AMMC-5026 Schematic.

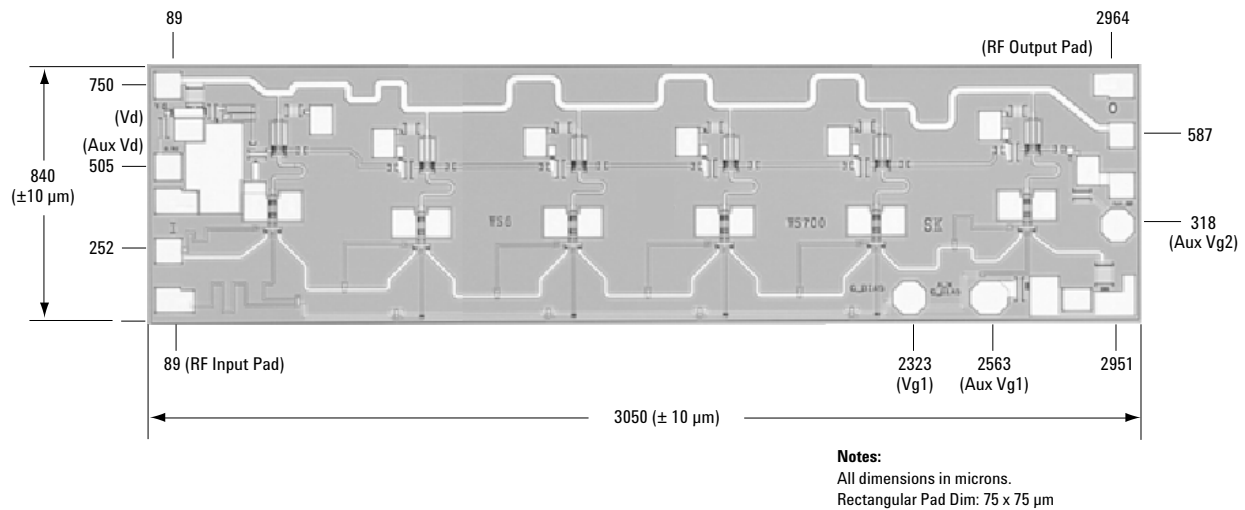

Figure 16. AMMC-5026 Bonding Pad Locations. (dimensions in micrometers)

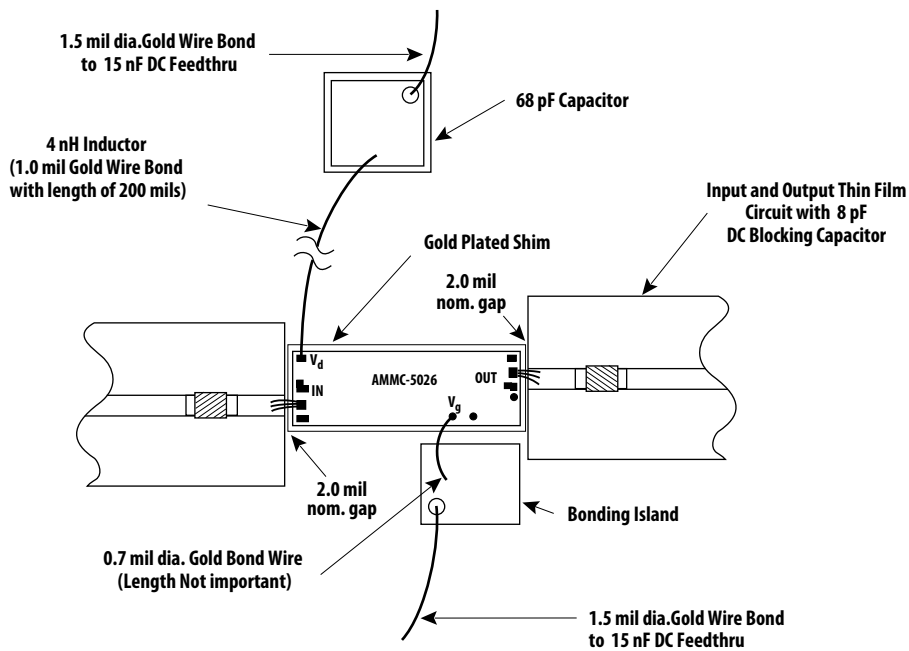

Figure 17. AMMC-5026 Assembly Diagram.

Ordering Information

AMMC-5026-W10 = 10 devices per tray

AMMC-5026-W50 = 50 devices per tray

For product information and a complete list of distributors, please go to our web site: www.avagotech.com

Avago, Avago Technologies, and the A logo are trademarks of Avago Technologies in the United States and other countries. Data subject to change. Copyright © 2005-2008 Avago Technologies. All rights reserved. Obsoletes 5989-3929EN AV02-1286EN - July 8, 2008

