

### Product Dimensions

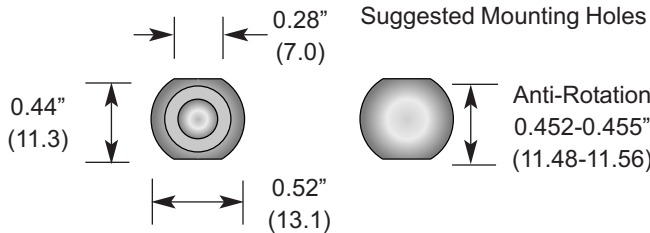

### Description

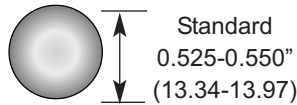
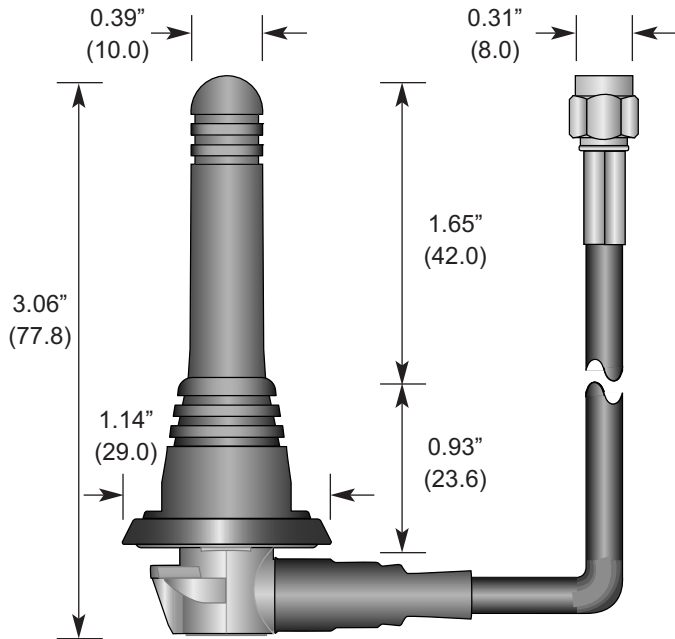

Designed for permanent mounting through a metal surface such as an automobile roof or trunk, the compact RMS Series offers excellent performance in a durable and unobtrusive housing. The antenna may be operated at either or both of two frequency bands. It is supplied with 14.1 feet (4.3m) of RG-58 cable and can be terminated in an FCC Part 15 compliant RP-SMA connector or a TNC connector.

### Features

- Dual-band (860-960MHz and 1.8GHz)
- Compact & unobtrusive
- Through-hole mount
- Low VSWR
- Excellent performance
- Omni-directional pattern
- Fully weatherized
- Rugged & damage-resistant
- RP-SMA or TNC connector

### Electrical Specifications

- Freq. Bands. Band 1 860-960MHz  
Band 2 1.8GHz
- Bandwidth 200MHz
- Wavelength 1/4-wave
- VSWR  $\leq 2.0$  typ. at center
- Impedance 50 ohms
- Connector RP-SMA or TNC
- Cable 14.1' RG-58 coax

### Ordering Information

- ANT-DB1-RMS-RPS (with RP-SMA connector)
- ANT-DB1-RMS-TNC (with TNC connector)

### VSWR Graph

