

**MULTILAYER CERAMIC ANTENNA (LINEAR POLARIZATION MODE)  
FOR GLOBAL POSITION SYSTEMS (1.575G Hz)**

Product Specification

**QUICK REFERENCE DATA**

Central Frequency	1.579 GHz	
Bandwidth	100 MHz	
Gain	1.5 dBi Max	
VSWR	2 max	
Polarization	Linear	
Azimuth	Omni-directional	
Impedance	50Ω	
Operating Temperature	-55~125 °C	
Termination	Ni/Sn (Environmentally-Friendly Leadless)	
Resistance to soldering heat	260°C, 10 sec.	



*Special Environmental Concerns- Green Products Design: The foil making process is using environmentally friendly aqueous solvent technology. Termination is lead free and packing materials can be re-cycled*

R&D	Print date 01/12/13		Preliminary use only			
	<b>Multilayer Ceramic Antenna (LP Mode) for GPS (1.575GHz)</b>		<b>4313 114 00158</b>		2001-3-29	
Cliff Wang, Ph.D.		2001-3-29	Page 1	sheet 190-1		A4
spec.doc	PHYCOMP					

## APPLICATION

### Suggested Layout

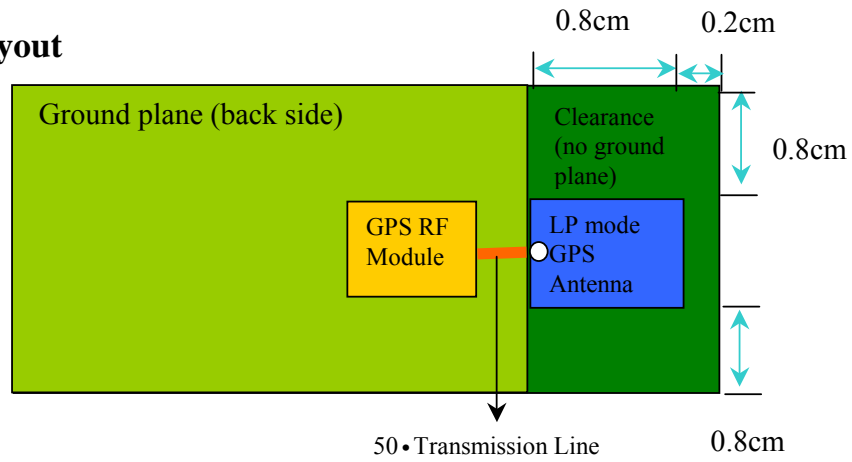

### Solder Land Pattern for LP GPS Antenna

Figure	Dimensions		Remark
	L	13.50 ± 0.10 mm	Feed pad
	W	7.00 ± 0.10 mm	
	F	1.00 ± 0.10 mm	
	C	0.90 ± 0.10 mm	Mount pad
	S1	1.40 ± 0.10 mm	
	S2	1.00 ± 0.10 mm	

R&D	Print date 01/12/13		Preliminary use only			
	Multilayer Ceramic Antenna (LP Mode) for GPS (1.575GHz)		4313 114 00158		2001-3-29	
Cliff Wang, Ph.D.					2001-3-29	Page 2
spec.doc	PHYCOMP					

## MECHANICAL DATA

Figure	Dimension	Port
	<p>L 12.5±0.25mm</p> <p>W 6.6±0.2mm</p> <p>T 0.9±0.2mm</p> <p>F 0.9±0.25mm</p> <p>C 0.5±0.3mm</p> <p>S1 1.25±0.35mm</p> <p>S2 0.9±0.25mm</p>	<p>-</p> <p>-</p> <p>-</p> <p>Feed termination</p> <p>-</p> <p>Solder termination</p> <p>Solder termination</p>

## ELECTRICAL DATA

Central Frequency	1.579 GHz
Bandwidth	100 MHz
Gain	1.57 dBi Max
VSWR	2 max
Polarization	Linear
Azimuth	Omni-directional
Impedance	50Ω
Operating Temperature	-55~125 °C
Termination	Ni/Sn (Environmentally-Friendly Leadless)
Resistance to soldering heat	260°C, 10 sec.

R&D	Print date 01/12/13	Preliminary use only				
		4313 114 00158			2001-3-29	
		Multilayer Ceramic Antenna (LP Mode) for GPS (1.575GHz)				
Cliff Wang, Ph.D.	2001-3-29	Page 3	sheet 190-3			A4
spec.doc	PHYCOMP					

## MEASUREMENT DATA

Standrd Testing Board for Radiation Pattern and S11(return loss)

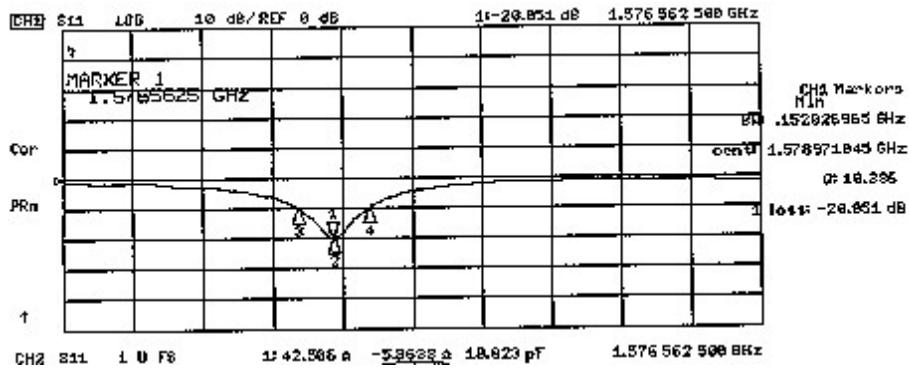
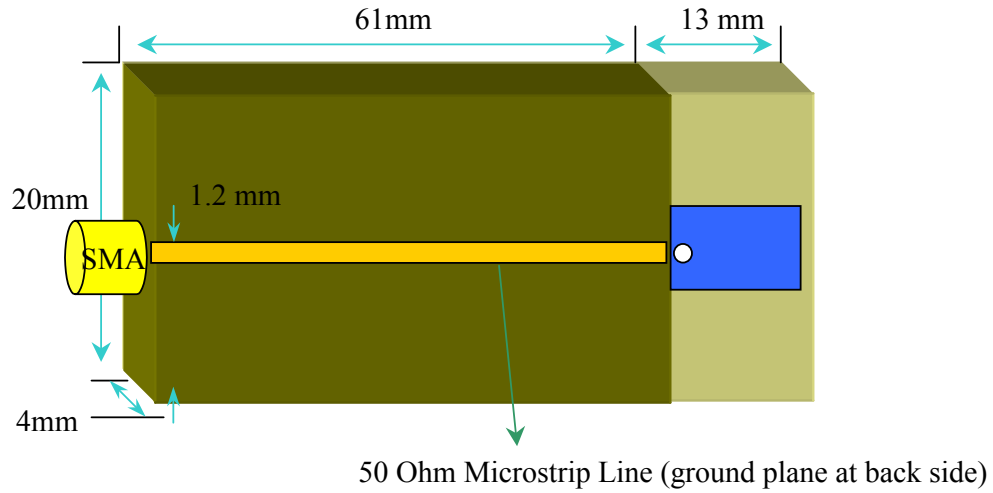

R&D	Print date 01/12/13		Preliminary use only			
	Multilayer Ceramic Antenna (LP Mode) for GPS (1.575GHz)		4313 114 00158		2001-3-29	
Cliff Wang, Ph.D.		2001-3-29	Page 4	sheet 190-4		A4
spec.doc	PHYCOMP					

Radiation Pattern Polar plot

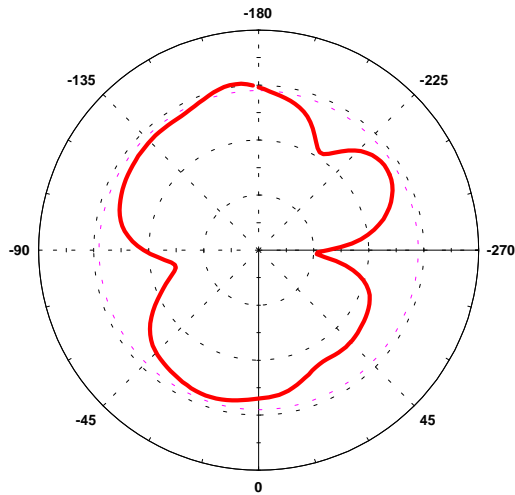

**E Plane**

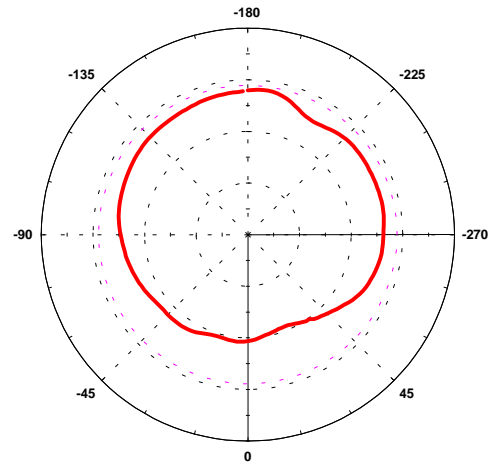

**H Plane**

R&D	Print date 01/12/13		Preliminary use only			
	Multilayer Ceramic Antenna (LP Mode) for GPS (1.575GHz)		4313 114 00158		2001-3-29	
Cliff Wang, Ph.D.		2001-3-29	Page 5	sheet 190-5		A4
spec.doc	PHYCOMP					

**RELIABILITY DATA (Reference to IEC Specification)**

IEC 384-10/ CECC 32 100 CLAUSE	IEC 6006868-2 TEST METHOD	TEST	PROCEDURE	REQUIREMENTS
4.4		Mounting	The antenna can be mounted on printed-circuit boards or ceramic substrates by applying wave soldering, reflow soldering (including vapour phase soldering) or conductive adhesive	No visible damage
4.5		Visual inspection and dimension check	Any applicable method using $\times 10$ magnification	In accordance with specification (no chip off 3 mm)
4.6.1		Antenna	Frequency = 1.575 GHz; at 20 °C	Standard test board in page 4
4.8		Adhesion	A force of 5 N applied for 10 s to the line joining the terminations and in a plane parallel to the substrate	No visible damage
4.9		Bond strength of plating on end face	Mounted in accordance with CECC 32 100, paragraph 4.4	No visible damage
			Conditions: bending 1mm at a rate of 1mm/s, radius jig. 340 mm, 1 mm warp on FR4 board of 90 mm length	No visible damage
4.10	Tb	Resistance to soldering heat	260 $\pm$ 5 °C for 10 $\pm$ 0.5 s in a static solder bath	The terminations shall be well tinned after recovery and Central Freq. Change $\pm$ 6%

R&D	Print date 01/12/13		Preliminary use only			
	<b>Multilayer Ceramic Antenna (LP Mode) for GPS (1.575GHz)</b>		<b>4313 114 00158</b>		2001-3-29	
Cliff Wang, Ph.D.		2001-3-29	Page 6	sheet 190-6		A4
spec.doc	PHYCOMP					

<b>IEC 384-10/ CECC 32 100 CLAUSE</b>	<b>IEC 6006868-2 TEST METHOD</b>	<b>TEST</b>	<b>PROCEDURE</b>	<b>REQUIREMENTS</b>
		Resistance to leaching	260 ± 5 °C for 30 ± 1 s in a static solder bath	Using visual enlargement of × 10, dissolution of the termination shall not exceed 10%
4.11	Ta	Solderability	Zero hour test, and test after storage (20 to 24 months) in original atmosphere; un-mounted chips completely immersed for 2 ± 0.5 s in 235 ± 5°C.	The termination must be well tinned, at least 75% is well tinned at termination
4.12	Na	Rapid change of temperature	-55 °C (30 minutes) to +125 °C (30 minutes); 100 cycles	No visible damage Central Freq. Change ± 6%
4.14	Ca	Damp heat	500 ± 12 hours at 60 °C; 90 to 95 % RH	No visible damage 2 hours recovery Central Freq. Change ± 6%
4.15		Endurance	500 ± 12 hours at 125 °C;	No visible damage 2 hours recovery Central Freq. Change ± 6%

R&D	Print date 01/12/13		Preliminary use only			
	<b>Multilayer Ceramic Antenna (LP Mode) for GPS (1.575GHz)</b>		<b>4313 114 00158</b>		2001-3-29	
Cliff Wang, Ph.D.		2001-3-29	Page 7	sheet 190-7		A4
spec.doc	PHYCOMP					

**ORDERING INFORMATION: 12NC Ordering Code**

The LP mode GPS antennas may be ordered by using the 12 NC ordering code. These code numbers can be determined by the following rules:

4313 1 14 00 158  
 F C M S T A

F. Family Code

**43** = Antenna

C. Packing Type Code

**13** = 330 mm/ 13" blister, 1000 pcs

M. Materials Code

**1** = High Frequency Material

S. Size Code

**14** = 12.5 \* 6.6 \* 0.9 mm

T. Tolerance

**00** = 100 M Hz Band Width

A. Working Frequency

**158** = 1.575 GHz

**Example: 12NC                    4313 114 00158**  
 Product description: Antenna (43) by 330 mm blister (12) of High Frequency Material (1), Size 12.5\*6.6\*0.9 mm (12); Tolerance (00) of 100 MHz (VSWR<2) Working Frequency (157) = 1.575G Hz

R&D	Print date 01/12/13		Preliminary use only			
	<b>Multilayer Ceramic Antenna (LP Mode) for GPS (1.575GHz)</b>	<b>4313 114 00158</b>	2001-3-29			
Cliff Wang, Ph.D.			2001-3-29	Page 8	sheet 190-8	A4
spec.doc	PHYCOMP					