



Specification

SPECIFICATION

- Part No. : **AP.10C.01**
- Product Name : 10mm SMT 15dB Active GPS Patch Antenna
- Features : Unique SMT GPS active patch
High performance
Ultra low power consumption
RoHS compliant
- Photo :



REVISION STATUS

Version	Date	Page	Revision Description	Prepared	Approved
01	Apr 9 th 2008	All	New product	TW Product Centre	Zita Lin
02	Oct 1st 2008	3	Temperature range	Ireland	Dermot O'Shea
02	Oct 23rd 2008	4	Suggested Layout added	Ireland	Dermot O'Shea



Specification

1.0 Introduction

The AP.10C.01 one stage 15dB active GPS patch antenna is the smallest SMT GPS high performance embedded antenna currently available in the world. Using extremely sensitive high dielectric constant powder formulation and tight process control the 10mm x 10mm x 4mm patch antenna is accurately tuned to have its frequency band right at 1575.42MHz for GPS systems. A patented SMT structure gives high reliability in integration. With an ultra low power consumption one stage LNA, this small active patch has the performance of an ordinary active patch, but at only a quarter of the size. This product is suited to small form factor mobile devices such as GPS Smartphones, Personal Location, Medical devices, Telematic devices and Automotive navigation and tracking. Custom gain, connector and cable versions are available.

2.0 Specification

Antenna

Frequency	1575.42 ± 1.023MHz
Gain	Typ -3dBic @ Zenith
Impedance	50Ω
Polarization	RHCP
Axial Ratio	Max 4.0dB @ Zenith
Dimension	10mm x 10mm x 4mm (add 7.3mm depth for vertical PCB)

LNA

Frequency	1575.42 ± 1.023MHz
Gain	Min. 13dB, Typ. 15dB @ 25°C ± 5°C
Noise Figure	Typ. 1.4dB @ 25°C ± 5°C Max 1.8dB @ 85°C
Output Impedance	50Ω
Output VSWR	Max. 2.0

Connection

Connection	SMT via solder pads
------------	---------------------



Specification

Total Specification

Frequency	1575.42 ± 1.023MHz
Gain	12 ± 4dBic @ 90°
Output Impedance	50 Ω
Polarization	RHCP
Output VSWR	Max 2.0
Operation Temperature	-40°C to + 85°C
Storage Temperature	-40°C to + 85°C
Relative Humidity	40% to 95%
Input Voltage	Min. 2.7V, Typ. 3.0V, Max. 3.3V
Current	Typ. 3mA, Max. 5mA



Specification

3.0 Technical Drawing

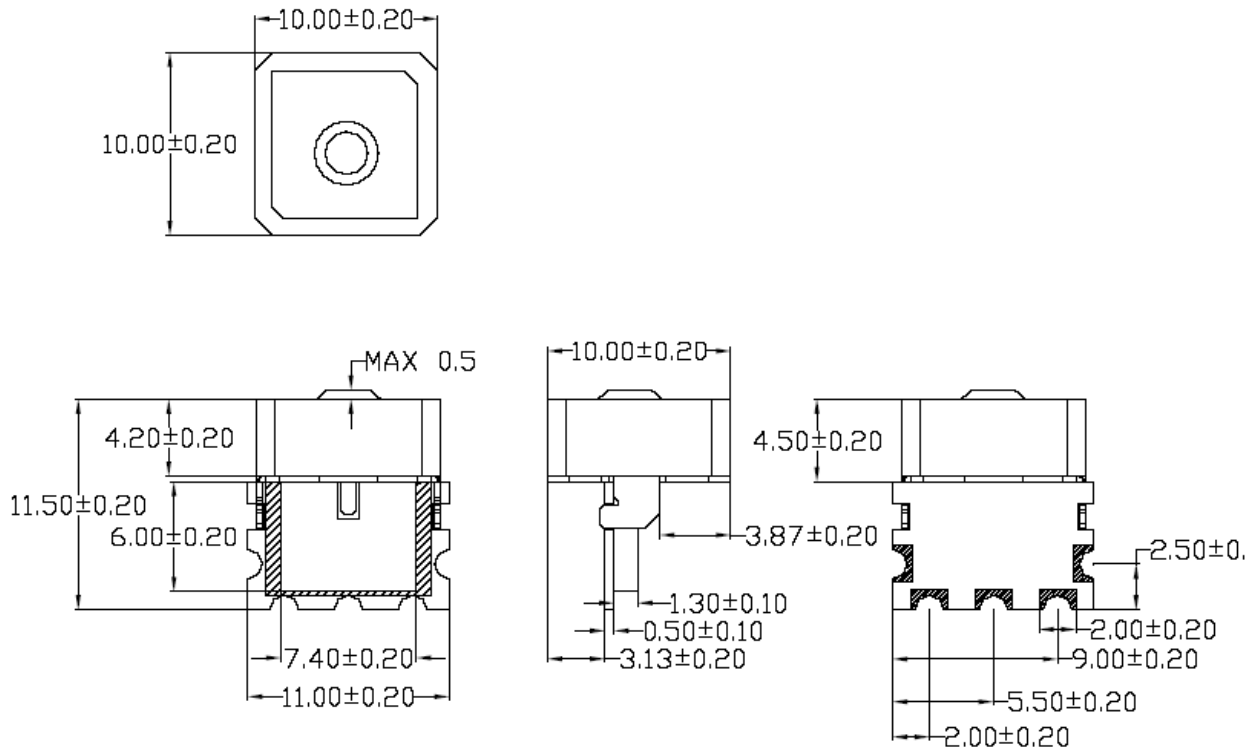

Unit:mm

