



Features

- Output Power > 0.5W P1dB
- High Linearity
- High Power-Added Efficiency
- Thermally-Enhanced Packaging
- Broadband Platform Design Approach, 450MHz to 2700MHz

Applications

- GaAs Pre-Driver for Basestation Amplifiers
- PA Stage for Commercial Wireless Infrastructure
- Class AB Operation for NMT, GSM, DCS, PCS, UMTS, and WLAN Transceiver Applications
- 2nd/3rd Stage LNA for Wireless Infrastructure

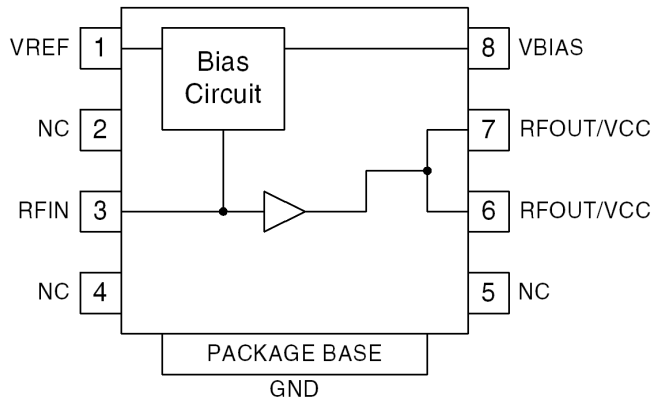

Functional Block Diagram

Product Description

The RF3807 is a GaAs pre-driver power amplifier, specifically designed for wireless infrastructure applications. Using a highly reliable GaAs HBT fabrication process, this high-performance single-stage amplifier achieves high output power over a broad frequency range. The RF3807 also provides excellent efficiency and thermal stability through the use of a thermally-enhanced surface-mount plastic-slug package. Ease of integration is accomplished through the incorporation of an optimized evaluation board design provided to achieve proper 50Ω operation. Various evaluation boards are available to address a broad range of wireless infrastructure applications: NMT 450MHz, GSM850, GSM900, DCS1800, PCS1900, and UMTS2100.

Ordering Information

RF3807	GaAs HBT Pre-Driver Amplifier
RF3807PCK-410	Fully Assembled Evaluation Board, 450MHz
RF3807PCK-411	Fully Assembled Evaluation Board, 869MHz to 894MHz
RF3807PCK-412	Fully Assembled Evaluation Board, 920MHz to 960MHz
RF3807PCK-413	Fully Assembled Evaluation Board, 1800MHz to 1880MHz
RF3807PCK-414	Fully Assembled Evaluation Board, 1930MHz to 1990MHz
RF3807PCK-415	Fully Assembled Evaluation Board, UMTS

Optimum Technology Matching® Applied

- | | | | |
|--|--------------------------------------|-------------------------------------|-----------------------------------|
| <input checked="" type="checkbox"/> GaAs HBT | <input type="checkbox"/> SiGe BiCMOS | <input type="checkbox"/> GaAs pHEMT | <input type="checkbox"/> GaN HEMT |
| <input type="checkbox"/> GaAs MESFET | <input type="checkbox"/> Si BiCMOS | <input type="checkbox"/> Si CMOS | <input type="checkbox"/> RF MEMS |
| <input type="checkbox"/> InGaP HBT | <input type="checkbox"/> SiGe HBT | <input type="checkbox"/> Si BJT | <input type="checkbox"/> LDMOS |

RF MICRO DEVICES®, RFMD®, Optimum Technology Matching®, Enabling Wireless Connectivity™, PowerStar®, POLARIS™ TOTAL RADIO™ and UltimateBlue™ are trademarks of RFMD, LLC. BLUETOOTH is a trademark owned by Bluetooth SIG, Inc., U.S.A. and licensed for use by RFMD. All other trade names, trademarks and registered trademarks are the property of their respective owners. ©2006, RF Micro Devices, Inc.

Absolute Maximum Ratings

Parameter	Rating	Unit
Supply Voltage (V_{CC} and V_{BIAS})	9.0	V
Reference Current (I_{REF})	30	mA
DC Supply Current	250	mA
Maximum Input Power	see below	
Output Load VSWR @ P1dB	4:1	
Operating Ambient Temperature	-40 to +85	°C
Storage Temperature	-40 to +150	°C



Caution! ESD sensitive device.

Exceeding any one or a combination of the Absolute Maximum Rating conditions may cause permanent damage to the device. Extended application of Absolute Maximum Rating conditions to the device may reduce device reliability. Specified typical performance or functional operation of the device under Absolute Maximum Rating conditions is not implied.

RoHS status based on EUDirective2002/95/EC (at time of this document revision).

The information in this publication is believed to be accurate and reliable. However, no responsibility is assumed by RF Micro Devices, Inc. ("RFMD") for its use, nor for any infringement of patents, or other rights of third parties, resulting from its use. No license is granted by implication or otherwise under any patent or patent rights of RFMD. RFMD reserves the right to change component circuitry, recommended application circuitry and specifications at any time without prior notice.

Parameter	Specification			Unit	Condition
	Min.	Typ.	Max.		
Overall - 450MHz					
Frequency	420		480	MHz	$I_{REF}=14\text{mA}$, $V_{CC}=8\text{V}$, $V_{REF}=8\text{V}$, $V_{BIAS}=8\text{V}$, Temp = +25 °C
P1dB		+29.0		dBm	
P_{IN} , Maximum			18	dBm	
Total Efficiency		53.5		%	@P1dB
Total Power Added Efficiency		52.5		%	@P1dB
Gain (S21)		16.5		dB	
Second Harmonic (2fo)		-19.0		dBc	@P1dB
Third Harmonic (3fo)		-21.0		dBc	@P1dB
Input Return Loss (S11)		-13.0		dB	
Output Return Loss (S22)		-6.5		dB	
Two-Tone Specification					
OIP3		40.0		dBm	15dBm/tone

Parameter	Specification			Unit	Condition
	Min.	Typ.	Max.		
Overall - GSM800					
Frequency	869		894	MHz	$I_{REF}=14\text{ mA}$, $V_{CC}=8\text{ V}$, $V_{REF}=8\text{ V}$, $V_{BIAS}=8\text{ V}$, Temp = +25 °C
P1dB	28	+30.5		dBm	Frequency=880MHz
P_{IN} , Maximum			16	dBm	
Total Efficiency		56		%	@P1dB
Total Power Added Efficiency		55		%	@P1dB
Gain (S21)	15.0	16.5	17.5	dB	Frequency=880MHz
Second Harmonic (2fo)		-20.0		dBc	@P1dB
Third Harmonic (3fo)		-39.0		dBc	@P1dB
Input Return Loss (S11)		-18.0		dB	
Output Return Loss (S22)		-12.0		dB	
Two-Tone Specification					
OIP3	41	44		dBm	15 dBm/tone, Frequency=880MHz
Overall - GSM900					
Frequency	920		960	MHz	$I_{REF}=14\text{ mA}$, $V_{CC}=8\text{ V}$, $V_{REF}=8\text{ V}$, $V_{BIAS}=8\text{ V}$, Temp = +25 °C
P1dB		+30.5		dBm	
P_{IN} , Maximum			16	dBm	
Total Efficiency		56		%	@P1dB
Total Power Added Efficiency		55		%	@P1dB
Gain (S21)		16.5		dB	
Second Harmonic (2fo)		-22.0		dBc	@P1dB
Third Harmonic (3fo)		-30.5		dBc	@P1dB
Input Return Loss (S11)		-22.0		dB	
Output Return Loss (S22)		-8.5		dB	
Two-Tone Specification					
OIP3		42.5		dBm	15 dBm/tone

Parameter	Specification			Unit	Condition
	Min.	Typ.	Max.		
Overall - DCS1800					
Frequency	1805		1880	MHz	$I_{REF}=14\text{mA}$, $V_{CC}=8\text{V}$, $V_{REF}=8\text{V}$, $V_{BIAS}=8\text{V}$, Temp = +25°C
P1dB		29.0		dBm	
P_{IN} , Maximum			18.0	dBm	
Total Efficiency		53.0		%	@P1dB
Total Power Added Efficiency		52.0		%	@P1dB
Gain (S21)		14.5		dB	
Second Harmonic (2fo)		-36.0		dBc	@P1dB
Third Harmonic (3fo)		-36.0		dBc	@P1dB
Input Return Loss (S11)		-14.0		dB	
Output Return Loss (S22)		-6.0		dB	
Two-Tone Specification					
OIP3		40.0		dBm	15 dBm/tone
Overall - PCS1900					
Frequency	1930		1990	MHz	$I_{REF}=14\text{mA}$, $V_{CC}=8\text{V}$, $V_{REF}=8\text{V}$, $V_{BIAS}=8\text{V}$, Temp = +25°C
P1dB		28.0		dBm	
P_{IN} , Maximum			18.0	dBm	
Total Efficiency		49.0		%	@P1dB
Total Power Added Efficiency		48.0		%	@P1dB
Gain (S21)		14.0		dB	
Second Harmonic (2fo)		-41.0		dBc	@P1dB
Third Harmonic (3fo)		-41.0		dBc	@P1dB
Input Return Loss (S11)		-12.0			
Output Return Loss (S22)		-7.0		dB	
Two-Tone Specification					
OIP3		39.5		dBm	15 dBm/tone

Parameter	Specification			Unit	Condition
	Min.	Typ.	Max.		
UMTS 2100					
Frequency	2110		2170	MHz	$I_{REF}=14\text{mA}$, $V_{CC}=8\text{V}$, $V_{REF}=8\text{V}$, $V_{BIAS}=8\text{V}$, Temp=+25°C
P1dB		+28.5		dBm	
P_{IN} , Maximum			18	dBm	
Total Efficiency		46		%	@P1dB
Total Power Added Efficiency		45		%	@P1dB
Gain (S21)		14.0		dB	
Second Harmonic (2fo)		-35.0		dBc	@P1dB
Third Harmonic (3fo)		-56.0		dBc	@P1dB
Input Return Loss (S11)		-16.0		dB	
Output Return Loss (S22)		-11.0		dB	
Two-Tone Specification					
OIP3		39.5		dBm	15 dBm/tone
Power Supply					
Power Supply Voltage	4.5	8.0	9.0	V	
Supply Current ($I_{CC}+I_{BIAS}$)	95	112	130	mA	$V_{CC}=V_{REF}=V_{BIAS}=8\text{V}$, $R_{BIAS}=340\Omega$
Control Current (I_{REF})		14		mA	$V_{CC}=V_{REF}=V_{BIAS}=8\text{V}$, $R_{BIAS}=340\Omega$
Power Down Current			30	μA	$V_{REF}=0\text{V}$, $V_{CC}=8\text{V}$

Bias Table

V_{CC}	V_{BIAS}	V_{REF}	R_{BIAS}	I_{REF}	I_{CQ}	Comments
8	8	8	340	14	111	
5	5	5	43	24	111	For equivalent I_{CQ} to 8V case

Pin	Function	Description
1	VREF	Control input to internal bias circuitry.
2	NC	No connection.
3	RFIN	Input for RF signal.
4	NC	No connection.
5	NC	No connection.
6	RFOUT/VCC	RF output pin and V _{CC} supply pin.
7	RFOUT/VCC	RF output pin and V _{CC} supply pin.
8	VBIAS	RF supply to internal bias circuitry.
Pkg Base	GND	Backside of package should be connected to a short path to ground.

Theory of Operation and Application Information

RF3807 design accommodates use in a variety of applications:

- Linear driver from 450MHz to 2200MHz
- 2nd/3rd stage high linearity LNA, with noise figure in the 3dB to 4dB range from 800MHz to 2200MHz
- High efficiency (>50%) output stage for non-linear applications
- 13dB gain, >37dBm typical OIP₃ when matched for WiMax 2.5GHz to 2.7GHz (see “Application Schematic” on page 8)

Nominal data sheet shows specification for $V_{CC}=V_{BIAS}=V_{REF}=8V$. RF3807 can easily be configured for 5V operation, with a simple bias resistor change at V_{REF} . “Bias Table” on page 5 shows resistor values for $V_{CC}=V_{BIAS}=V_{REF}=5V$. Generally speaking, 5V data will compare to that for 8V as follows:

- 3dB to 3.5dB reduction in OP1dB
- 0.4dB to 0.5dB increase in small signal gain

For operation at other than 5V, bias R can be calculated as follows ($V_{CC}=V_{BIAS}=V_{REF}=5V$ is used here to illustrate, operation at different voltage is determined with same methodology).

1. Use nominal 8V case as a starting point: $V_{CC}=V_{BIAS}=V_{REF}=8V$, $I_{REF}=14mA$, $I_{CQ}=112mA$. Target condition will be to achieve same I_{CQ} with $V_{CC}=V_{BIAS}=V_{REF}=5V$.
2. Using standard evaluation board with separate lab supplies on (V_{CC}/V_{BIAS}) and (V_{REF}), set $V_{CC}/V_{BIAS}=5V$, $V_{REF}=8V$. I_{REF} is maintained at 14mA, and I_{CQ} drops from nominal value of 112mA.
3. V_{REF} can then be increased >8V until I_{CQ} is restored. I_{REF} increase to 24mA is required (as seen in “Bias Table” on page 5).
4. At this point, pin voltage at V_{REF} is calculated (or measured with DVM): $V_{PIN}=V_{REF}$ at eval board input – $I_{REF} * \text{bias } R = 12.1 - 0.024 * 340 = 3.94V$.
5. Next, calculate new bias R for $V_{REF}=5V$: $\text{Bias } R = (5 - 3.94) / 0.024 = 44\Omega$. See “Bias Table” on page 5, standard resistor value = 43Ω is called out. In this way, bias R can be calculated for any $V_{CC}=V_{BIAS}=V_{REF}$ configuration. The maximum I_{REF} limit for RF3807 = 30mA.

Junction-to-case thermal resistance (R_{TH_JC}) is shown versus output power in the graph section of this data sheet. The graph was generated with nominal $V_{CC}=V_{BIAS}=V_{REF}=8V$, $I_{REF}=14mA$, where ambient temperature = 85°C. Using this curve along with operating condition, junction temperature can be calculated. Resultant T_J for this case yields MTTF > 100 years. Standard RF3807 evaluation boards are matched for high efficiency at O_{P1dB} . To ensure reliability for operation at high power, output match achieving equivalent or better efficiency on system board should be the goal.

Typical s-parameter responses for each evaluation board are shown within the data sheet. These boards were matched with two specifications in mind:

- Output load impedance set for optimum OIP₃/ACP (Adjacent Channel Power for commonly used modulation standards).
- Output load impedance set for high efficiency at O_{P1dB} , with ruggedness (survival) into output 4:1 VSWR.

In some cases, low power operation being one, it may be desirable to improve output return loss seen on evaluation board. This can be done with output match adjust. The result will be an increase in small signal gain. Tradeoffs between return loss, gain, OIP₃, and compression point can then be considered in obtaining optimum performance for a particular application.

Finally, infrastructure qualification report for RF3807 can be obtained by contacting RFMD.

Application Schematic

WiMax 2.5GHz to 2.7GHz ($V_{CC}=V_{BIAS}=V_{REF}=5V$)

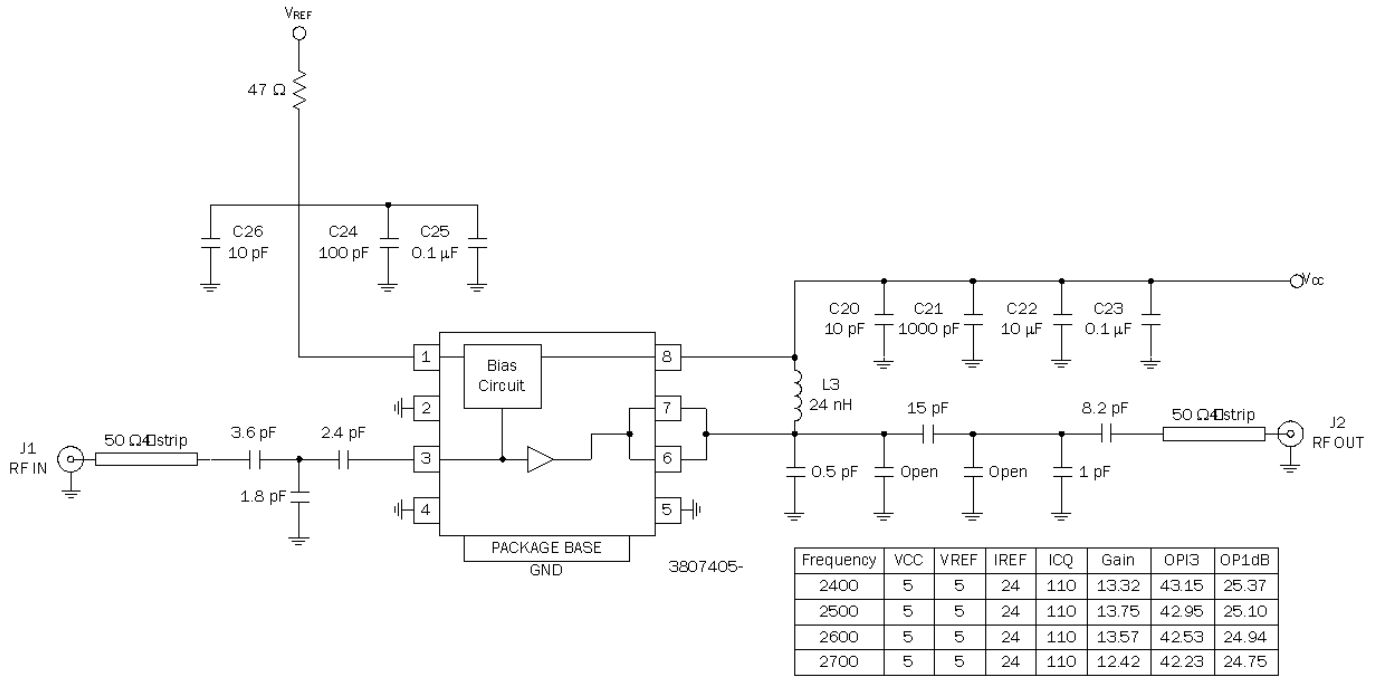

Package Drawing

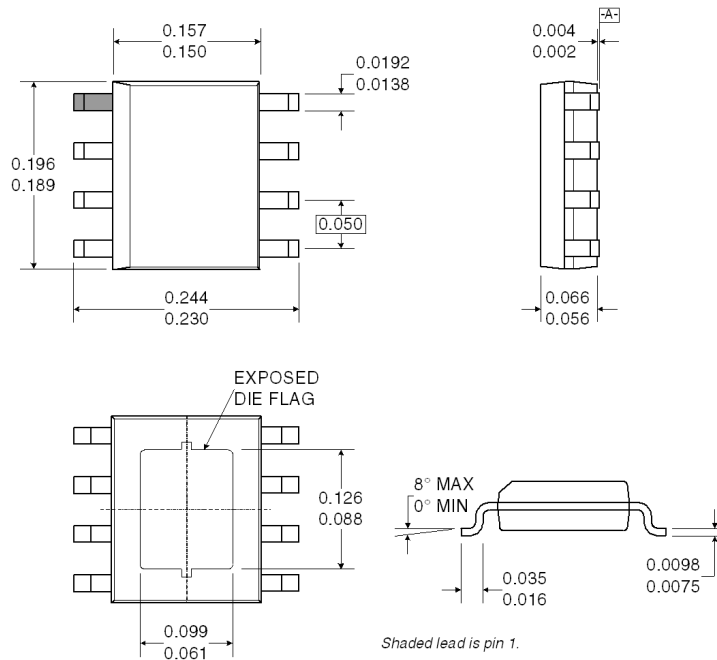

Evaluation Board Schematic
450MHz (RF3807410)

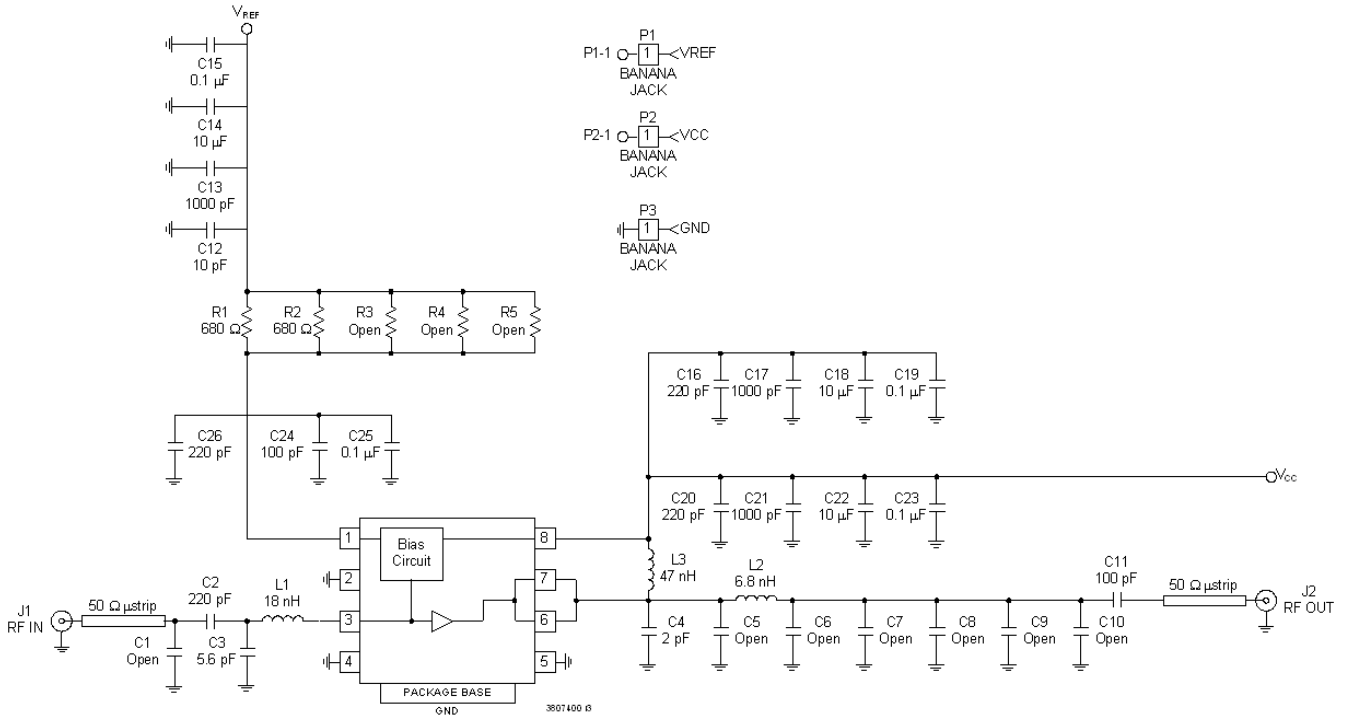

Evaluation Board Schematic
869MHz to 894 MHz (GSM800) (RF3807411)

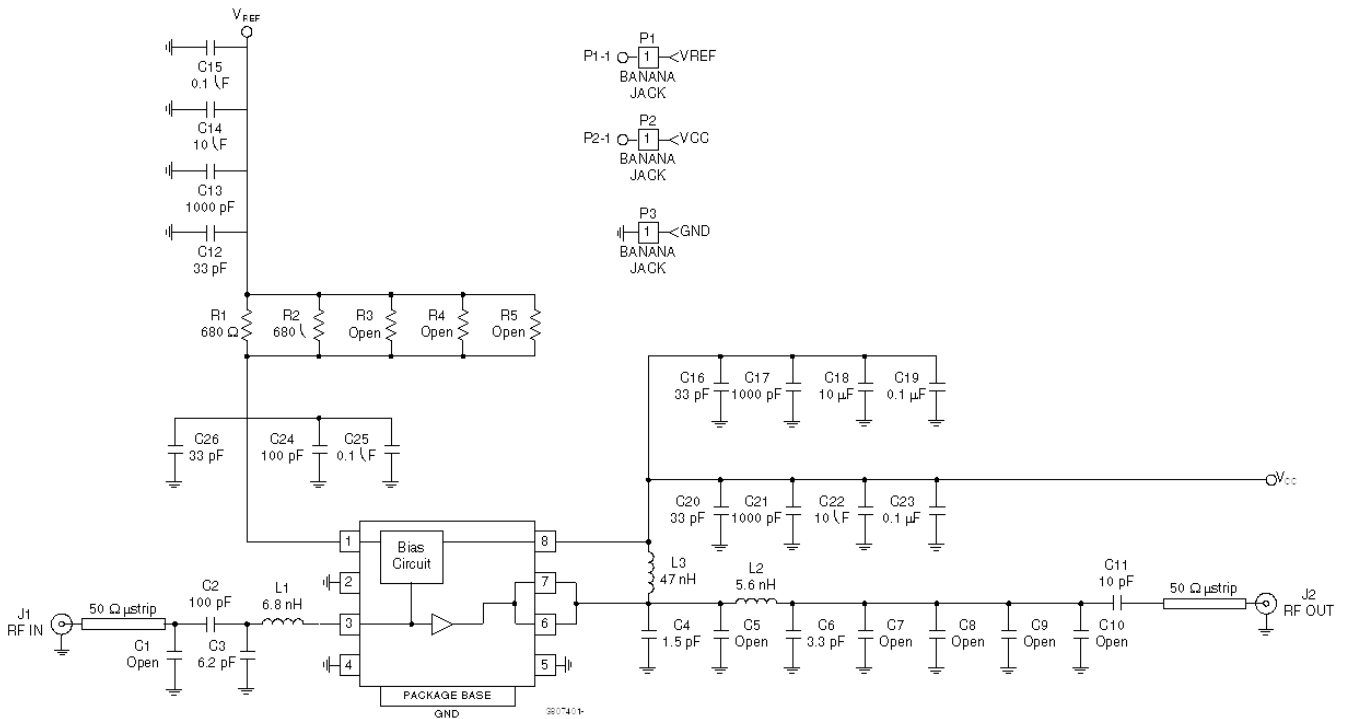

Evaluation Board Schematic 920MHz to 960MHz (GSM900) (RF3807412)

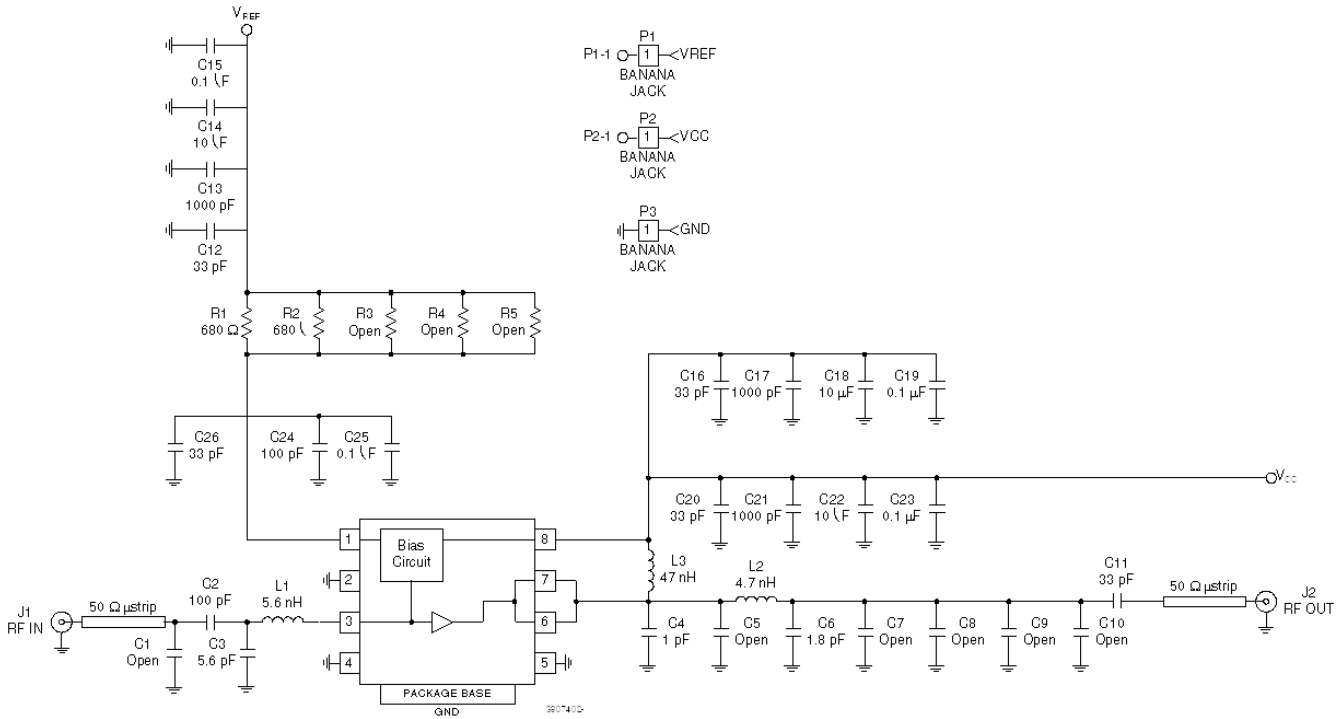

Evaluation Board Schematic 1800MHz to 1880MHz (DCS1800) (RF3807413)

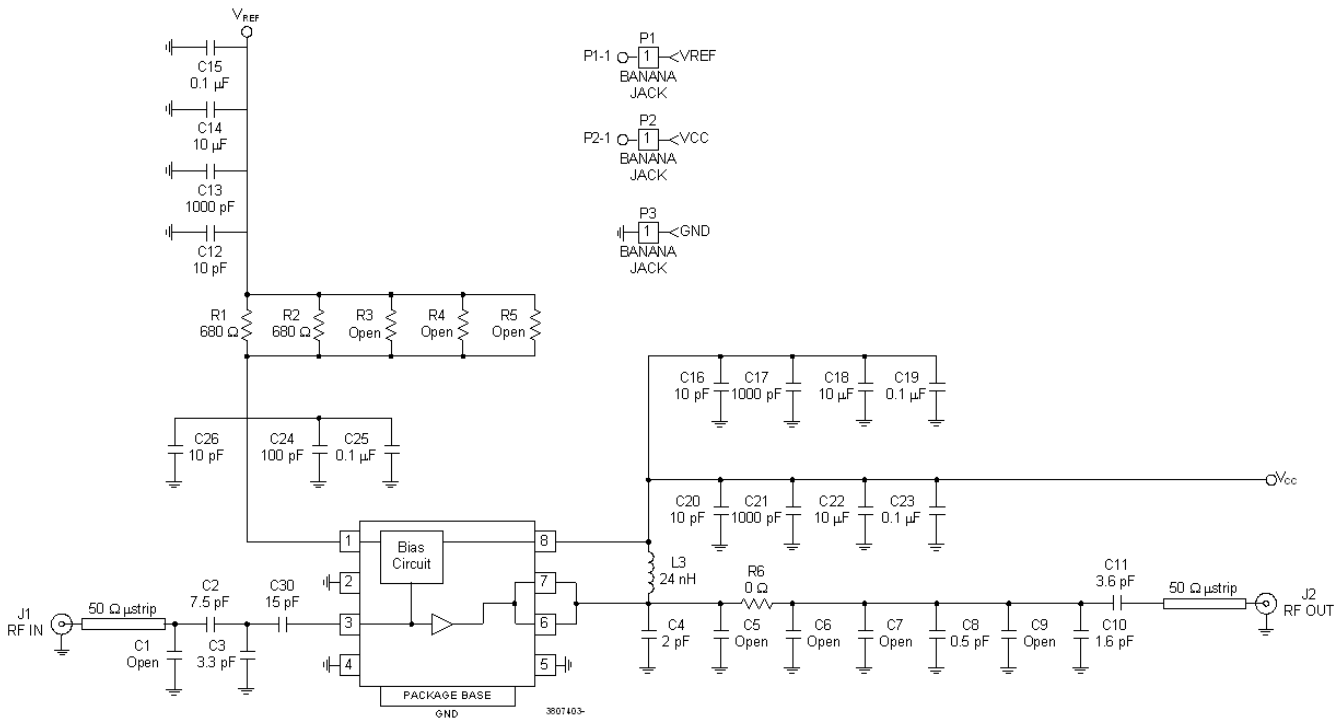

Evaluation Board Schematic
1930MHz to 1990MHz (PCS1900) (RF3807414)

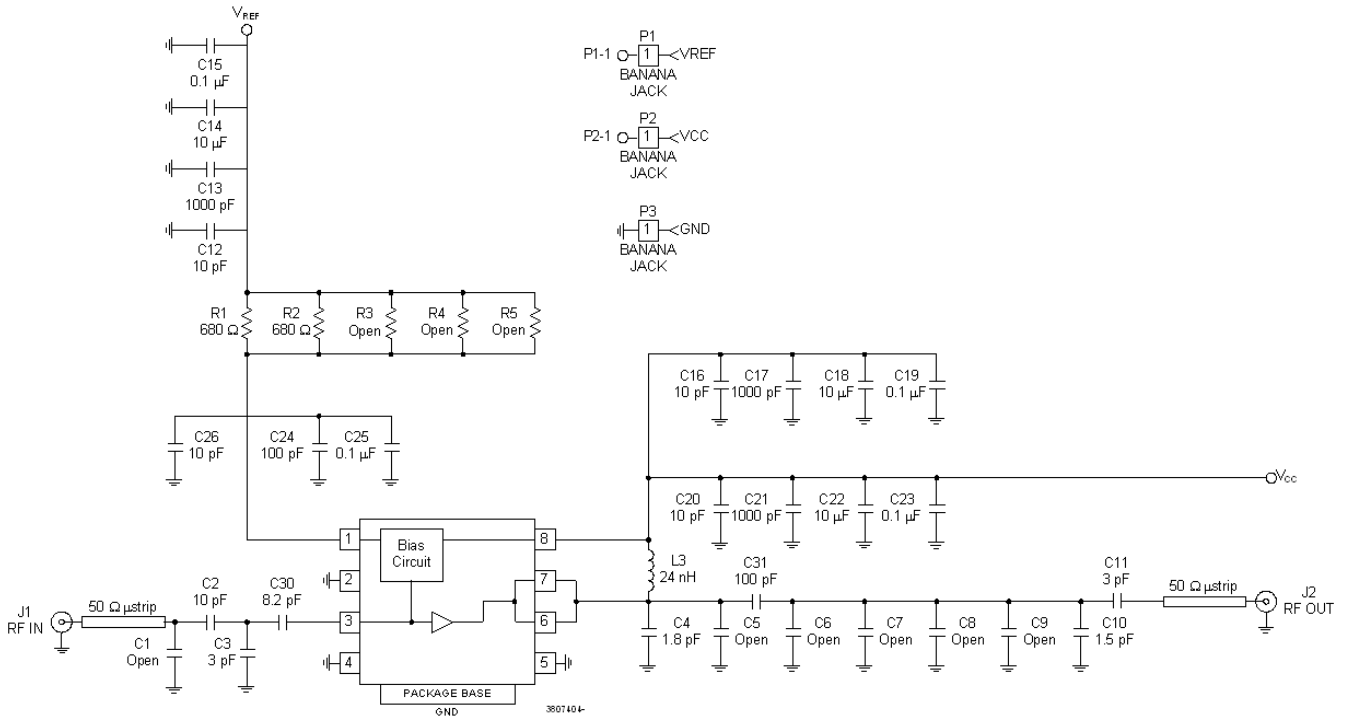

Evaluation Board Schematic
UMTS (RF3807415)

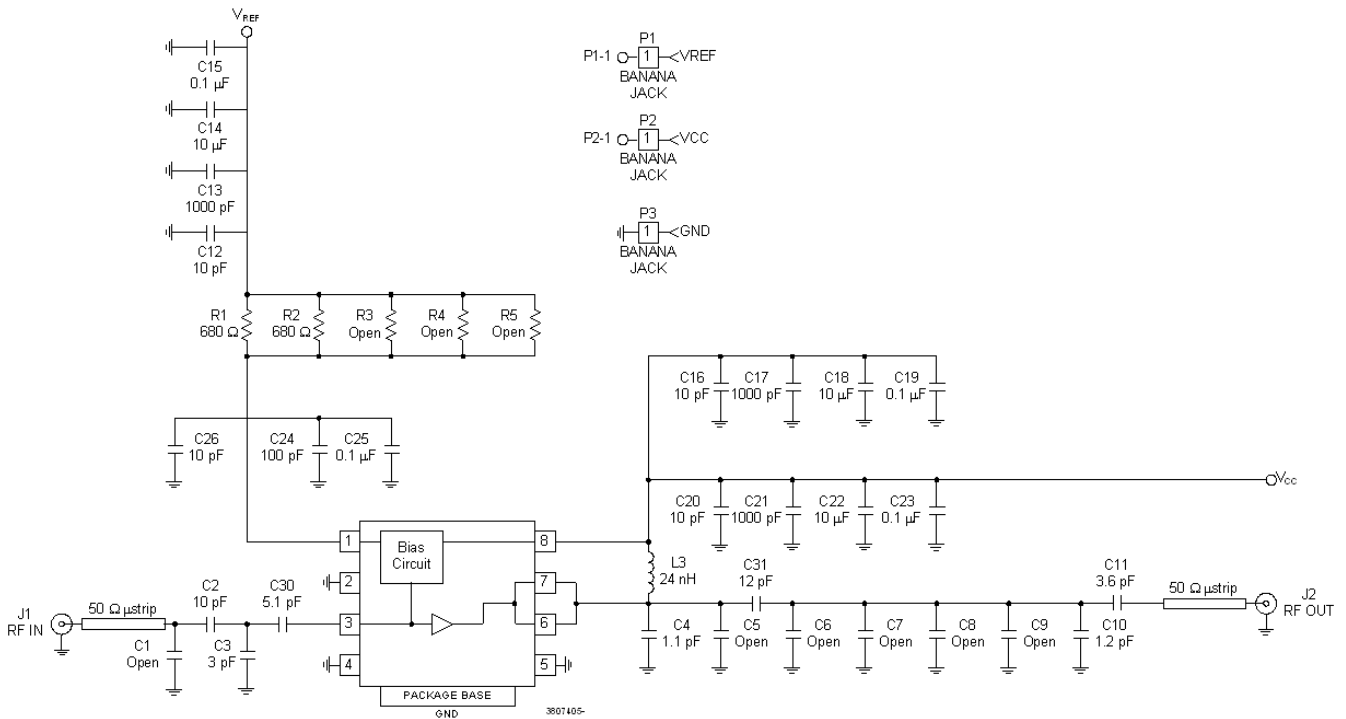

Evaluation Board Layout - 400MHz Board Size 2.0" x 2.0" Board Thickness 0.023", Board Material Rogers 4530

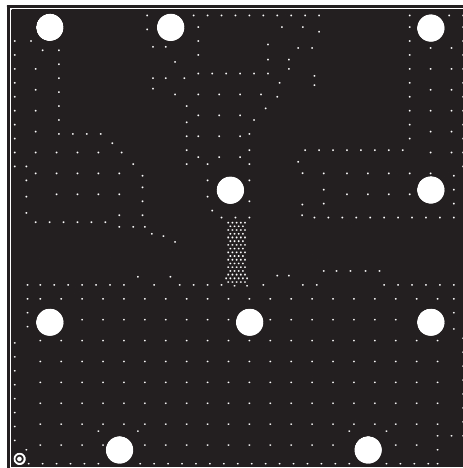
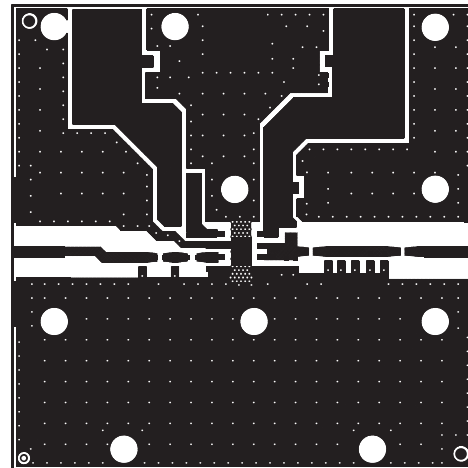
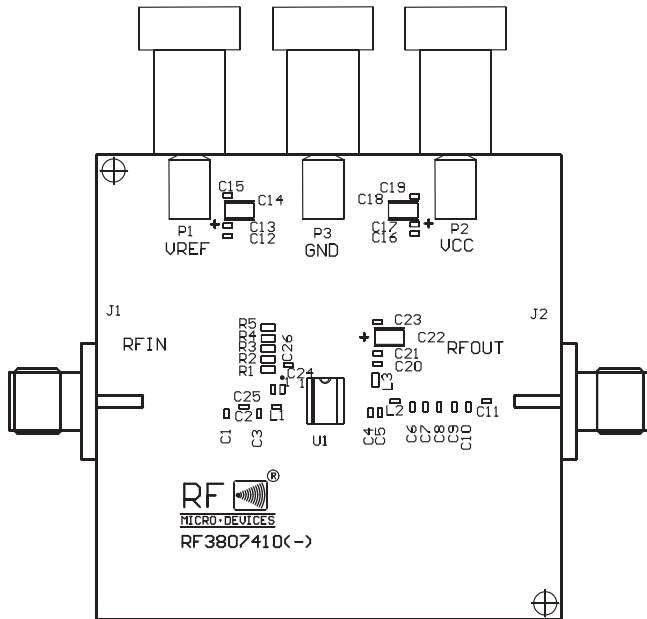

PCB Design Requirements

PCB Surface Finish

The PCB surface finish used for RFMD's qualification process is electroless nickel, immersion gold. Typical thickness is 3µinch to 8µinch gold over 180µinch nickel.

PCB Land Pattern Recommendation

PCB land patterns for PFMD components are based on IPC-7351 standards and RFMD empirical data. The pad pattern shown has been developed and tested for optimized assembly at RFMD. The PCB land pattern has been developed to accommodate lead and package tolerances. Since surface mount processes vary from company to company, careful process development is recommended.

PCB Metal Land Pattern

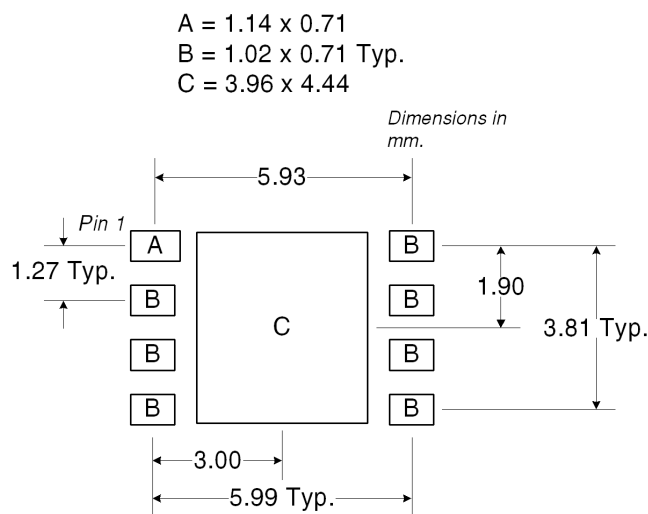

PCB Solder Mask Pattern

Liquid Photo-Imageable (LPI) solder mask is recommended. The solder mask footprint will match what is shown for the PCB metal land pattern with a 2mil to 3mil expansion to accommodate solder mask registration clearance around all pads. The center-grounding pad shall also have a solder mask clearance. Expansion of the pads to create solder mask clearance can be provided in the master data or requested from the PCB fabrication supplier.

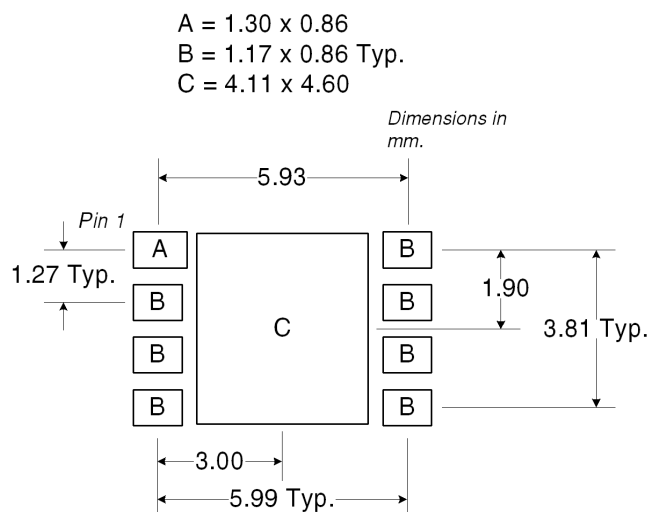

Thermal Pad and Via Design

The DUT must be connected to the PCB backside ground through a low inductance, low thermal resistance path. The required interface is achieved with the via pattern shown below for both low inductance as well as low thermal resistance. The footprint provided below worked well on the RFMD 20mil thick Rogers 4350 PCB and also standard FR4. The vias are 8mil vias that are partially plated through and are finished to 8mils±2mils with a minimum plating of 1.5mil. Failure to place these vias within the DUT mounting area on the PCB in this prescribed manner may result in electrical performance and/or reliability degradation.

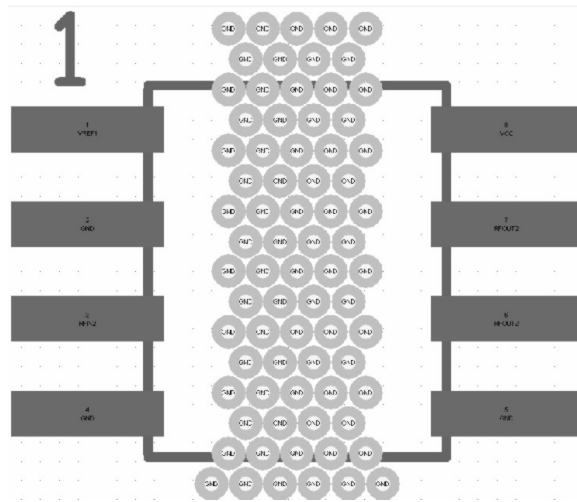

Tape and Reel Information

Carrier tape basic dimensions are based on EIA481. The pocket is designed to hold the part for shipping and loading onto SMT manufacturing equipment, while protecting the board and the solder terminals from damaging stresses. The individual pocket design can vary from vendor to vendor, but width and pitch will be consistent.

Carrier tape is wound or placed on a shipping reel with a diameter of either 330mm (13 inches) or 178mm (7 inches). The center hub design is large enough to ensure the radius formed by the carrier tape around it does not put unnecessary stress on the parts.

Prior to shipping, moisture sensitive parts (MSL level 2a to 5a) are baked and placed into the pockets of the carrier tape. A cover tape is sealed over the top of the entire length of the carrier tape. The reel is sealed in a moisture barrier, ESD bag, which is placed in a cardboard shipping box. It is important to note that unused moisture sensitive parts need to be resealed in the moisture barrier bag. If the reels exceed the exposure limit and need to be rebaked, most carrier tape and shipping reels are not rated as bakeable at 125°C. If baking is required, devices may be baked according to section 4, table 4-1, column 8 of Joint Industry Standard IPC/JEDECJ-STD-033A.

The following table provides useful information for carrier tape and reels used for shipping the devices described in this document.

RFMD Part Number	Reel Diameter Inch (mm)	Hub Diameter Inch (mm)	Width (mm)	Pocket Pitch (mm)	Feed	Units per Reel
RF3807TR13	13 (330)	4 (102)	12	8	Single	2500
RF3807TR7	7 (178)	2.4 (61)	12	8	Single	750

Carrier Tape Drawing with Part Orientation

Notes:

- All dimensions are in millimeters (mm).
- Unless otherwise specified, all dimension tolerances per EIA-481.

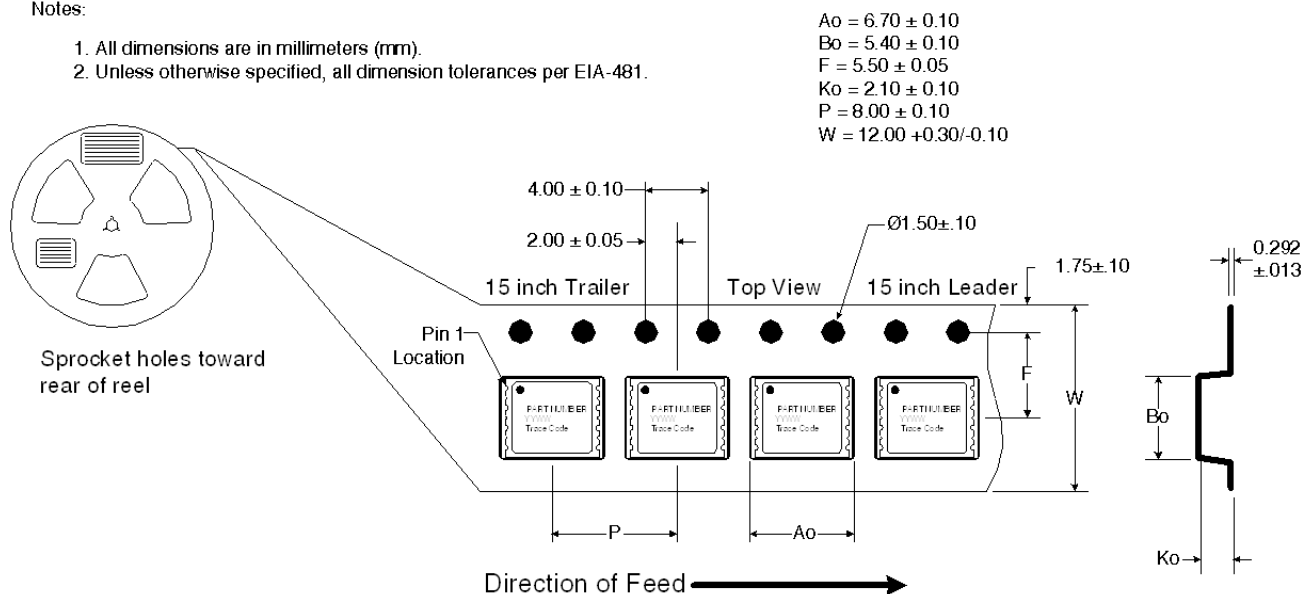

CDMA2K ACPR Performance for RS SMIQ03HD Sig Gen & FSU8 Spec Analyzer (1960 MHz, 882 MHz, & 450 MHz Source Signals)

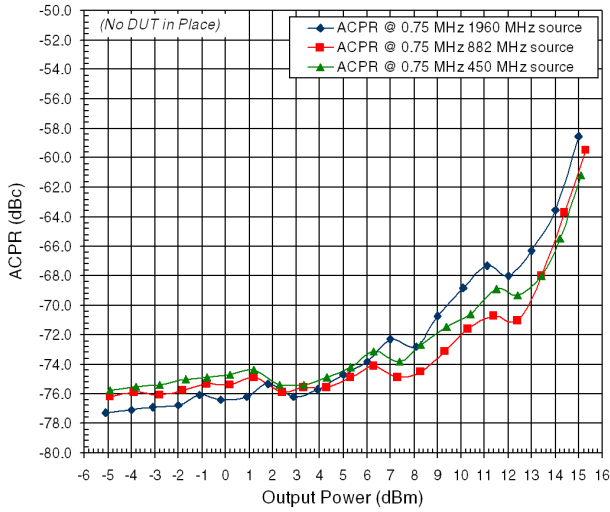

W-CDMA ACPR Performance for RS SMIQ03HD Sig Gen & FSU8 Spec Analyzer (2140 MHz & 882 MHz Source Signals)

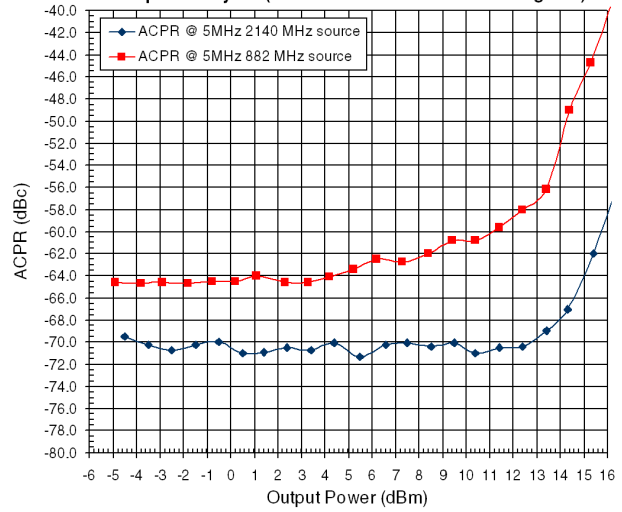

**RF3807410 @ 450 MHz CDMA2K
SR1 and 9 Channels**

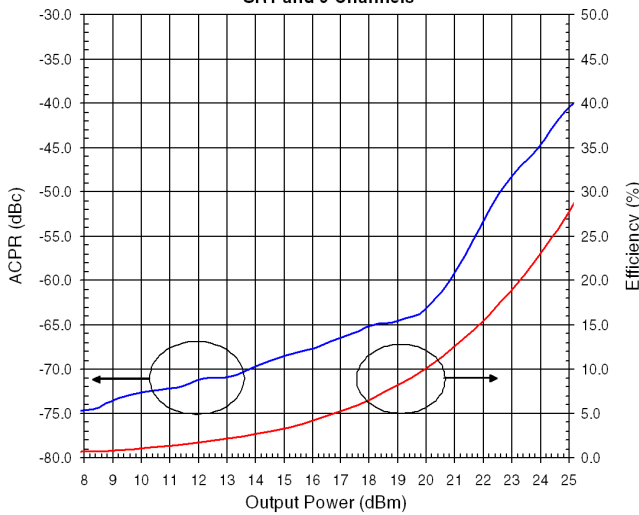

**RF3807411 @ 882 MHz CDMA2K
SR1 and 9 Channels**

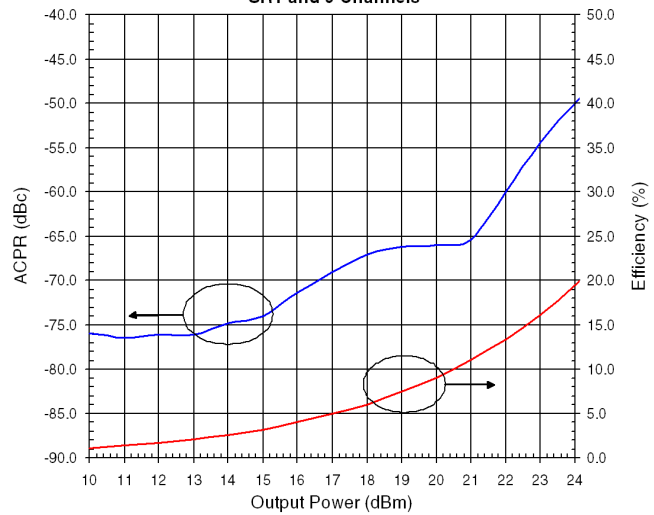

**RF3807412 @ 940 MHz
EDGE EVM**

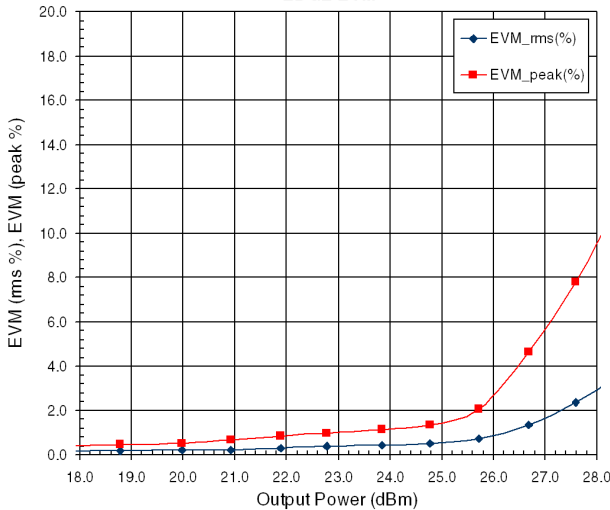

**RF3807413 @ 1840 MHz
EDGE EVM**

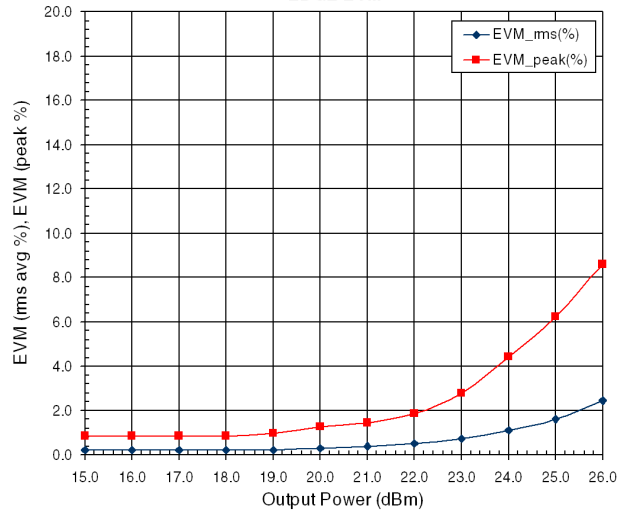

**RF3807414 @ 1960 MHz CDMA2K
SR1 and 9 Channels**

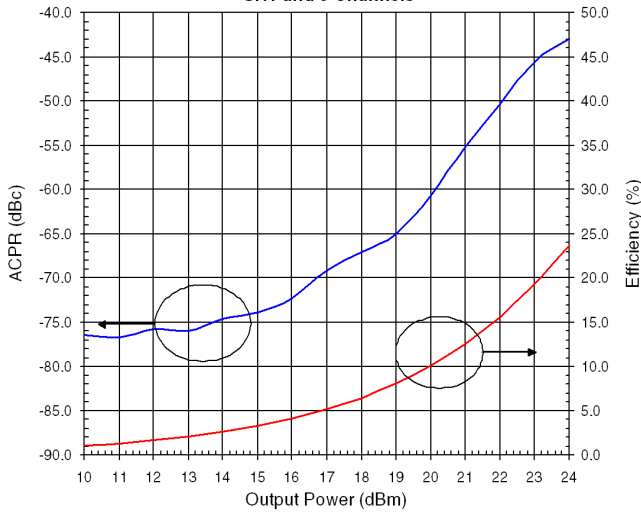

**RF3807415 @ 2140 MHz UMTS W-CDMA
64 Channels with No Clipping**

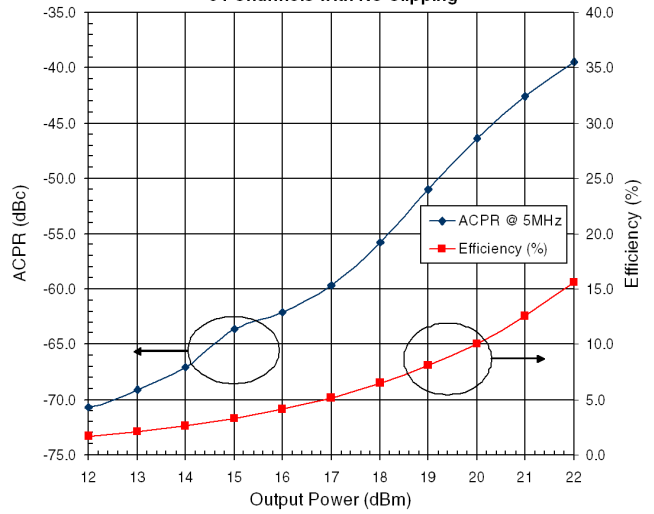

**RF3807411 @ 882 MHz W-CDMA
64 Channels and No Clipping**

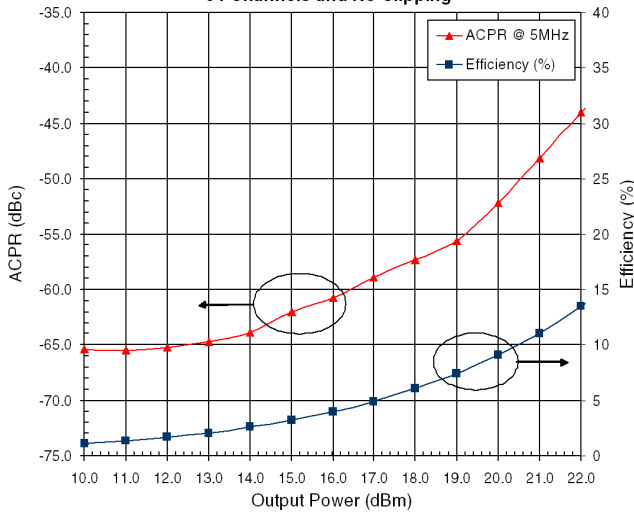

**RF3807412 @ 940 MHz
EDGE EVM**

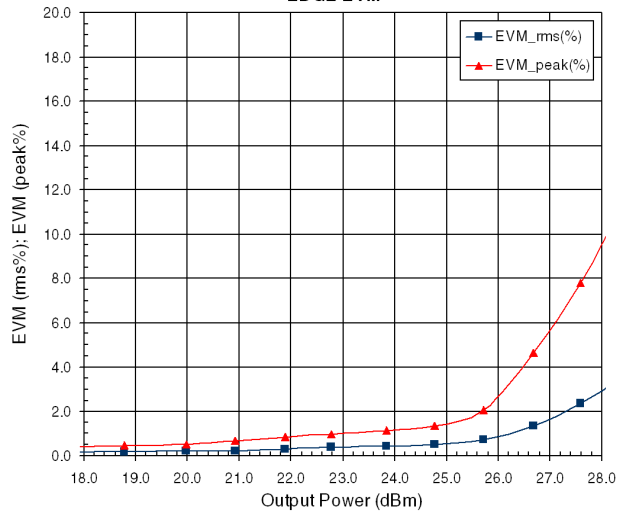

**RF3807413 @ 1840 MHz
EDGE EVM**

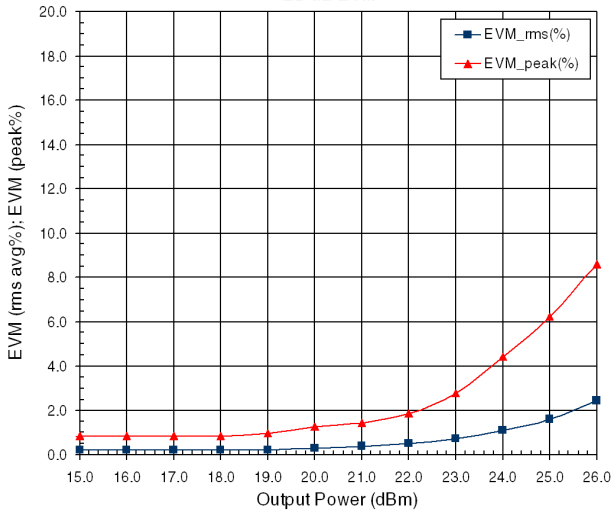

RF3807410 Evaluation Board S-Parameters

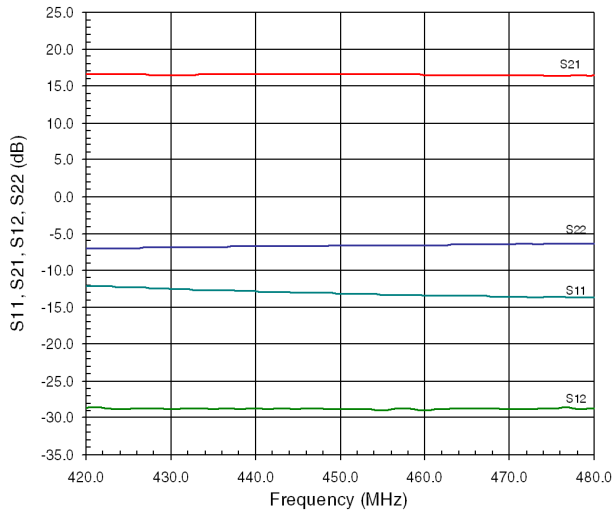

RF3807411 Evaluation Board S-Parameters

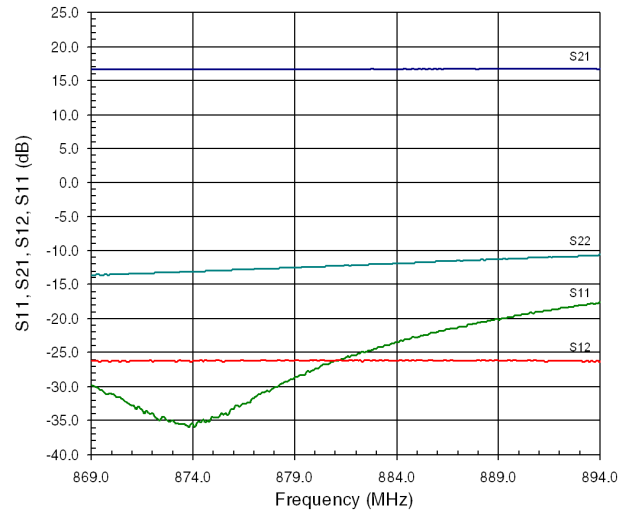

RF3807412 Evaluation Board S-Parameters

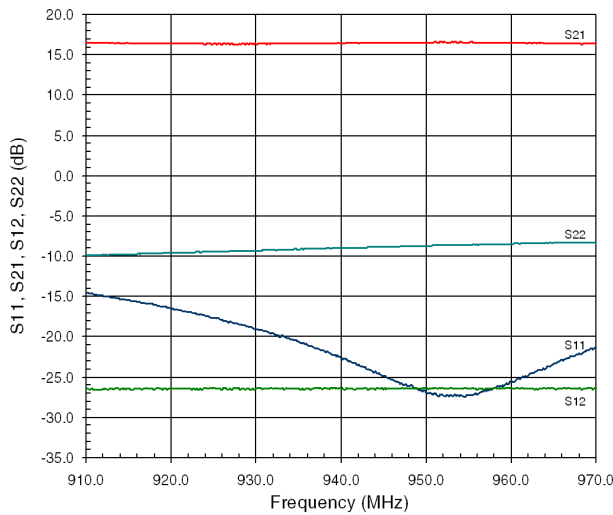

RF3807413 Evaluation Board S-Parameters

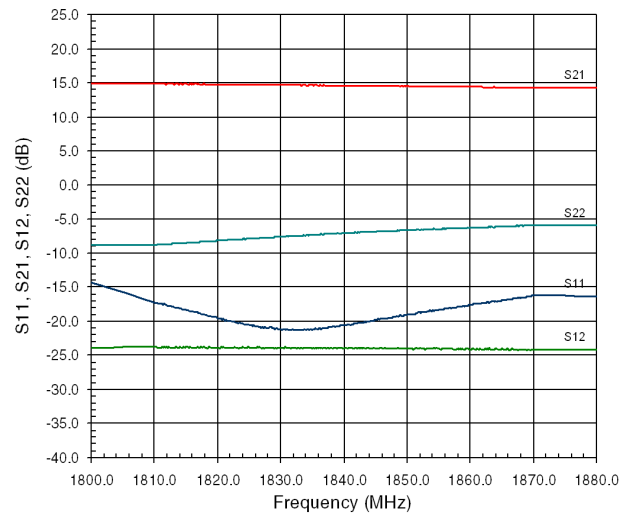

RF3807414 Evaluation Board S-Parameters

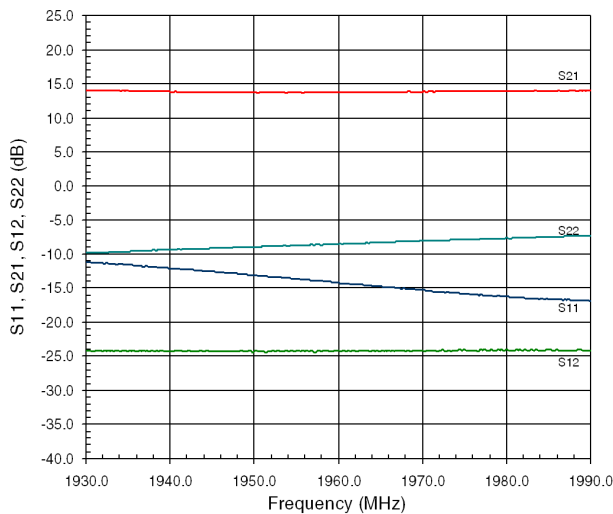

RF3807415 Evaluation Board S-Parameters

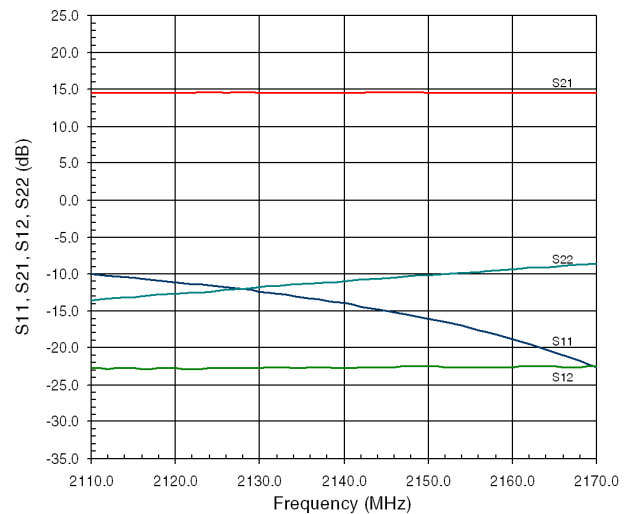

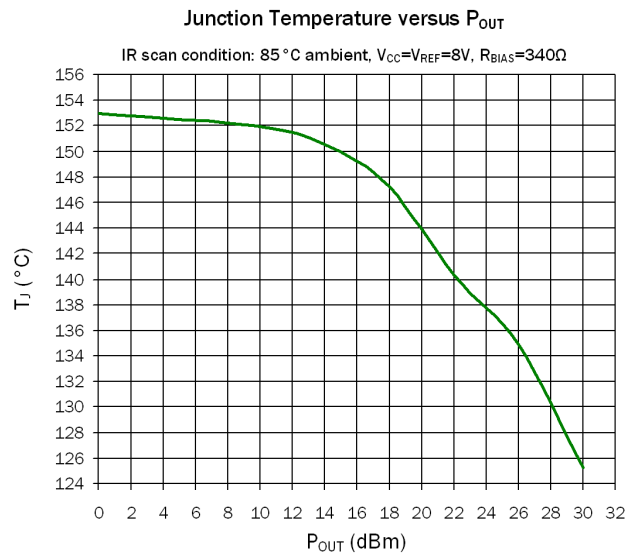
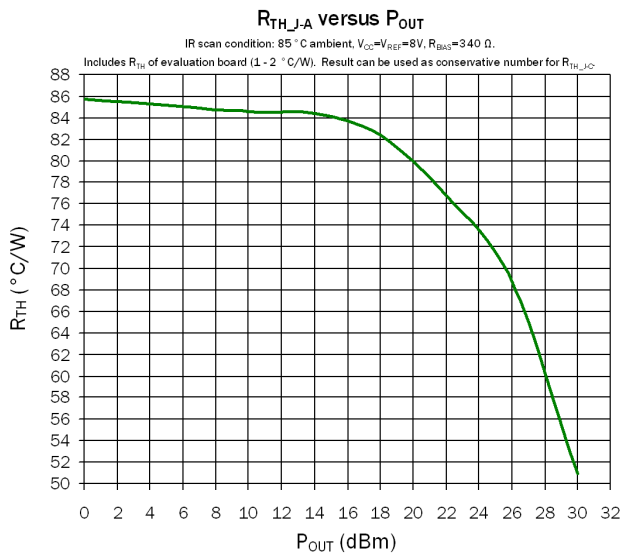

RoHS* Banned Material Content

RoHS Compliant: Yes
 Package total weight in grams (g): 0.08
 Compliance Date Code: N/A
 Bill of Materials Revision: A
 Pb Free Category: e3

Bill of Materials	Parts Per Million (PPM)					
	Pb	Cd	Hg	Cr VI	PBB	PBDE
Die	0	0	0	0	0	0
Molding Compound	0	0	0	0	0	0
Lead Frame	0	0	0	0	0	0
Die Attach Epoxy	0	0	0	0	0	0
Wire	0	0	0	0	0	0
Solder Plating	0	0	0	0	0	0

This RoHS banned material content declaration was prepared solely on information, including analytical data, provided to RFMD by its suppliers, and applies to the Bill of Materials (BOM) revision noted above.

* DIRECTIVE 2002/95/EC OF THE EUROPEAN PARLIAMENT AND OF THE COUNCIL of 27 January 2003 on the restriction of the use of certain hazardous substances in electrical and electronic equipment