

Data Sheet

Description

The MSA-9970 is a high performance silicon bipolar Monolithic Microwave Integrated Circuit (MMIC) housed in a hermetic high reliability package. This MMIC is designed with high open loop gain and is intended to be used with external resistive and reactive feedback elements to create a variety of special purpose gain blocks.

Applications include very broadband, minimum ripple amplifiers with extended low frequency performance possible through the use of a high valued external feedback blocking capacitor; extremely well matched (-20 dB return loss) amplifiers; and negative gain slope amplifiers for flattening MMIC cascades.

The MSA-series is fabricated using Avago's 10 GHz f_T , 25 GHz f_{MAX} , silicon bipolar MMIC process which uses nitride self-alignment, ion implantation, and gold metallization to achieve excellent performance, uniformity and reliability. The use of an external bias resistor for temperature and current stability also allows bias flexibility.

Features

- Open Loop Feedback Amplifier
- Performance Flexibility with User Selected External Feedback for:
 - Broadband Minimum Ripple Amplifiers
 - Low Return Loss Amplifiers
 - Negative Gain Slope Amplifiers
- Usable Gain to 6.0 GHz
- 16.0 dB Typical Open Loop Gain at 1.0 GHz
- 14.5 dBm Typical P_{1dB} at 1.0 GHz
- Hermetic Gold-ceramic Microstrip Package

70 mil Package

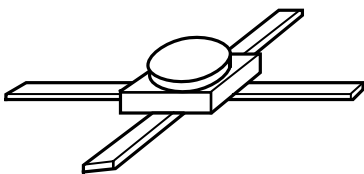

Typical Biasing Configuration

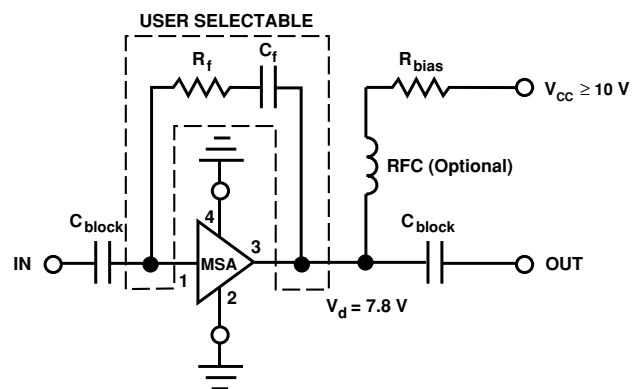

MSA-9970 Absolute Maximum Ratings

Parameter	Absolute Maximum ^[1]
Device Current	80 mA
Power Dissipation ^[2,3]	750 mW
RF Input Power	+13 dBm
Junction Temperature	200°C
Storage Temperature	-65°C to 200°C

Thermal Resistance^[2,4]:

$$\theta_{jc} = 150^{\circ}\text{C/W}$$

Notes:

1. Permanent damage may occur if any of these limits are exceeded.
2. $T_{\text{CASE}} = 25^{\circ}\text{C}$.
3. Derate at 6.7 mW/°C for $T_{\text{C}} > 88^{\circ}\text{C}$.
4. The small spot size of this technique results in a higher, though more accurate determination of θ_{jc} than do alternate methods.

Electrical Specifications^[1], $T_{\text{A}} = 25^{\circ}\text{C}$

Symbol	Parameters and Test Conditions: $I_{\text{d}} = 35 \text{ mA}$, $Z_0 = 50 \Omega$	Units	Min.	Typ.	Max.	
G_{p}	Power Gain ^[2] ($ S_{21} ^2$)	f = 0.1 GHz		17.5		
			f = 1.0 GHz	14.5	16.0	17.5
			f = 4.0 GHz	8.0	9.0	10.0
$P_{1 \text{ dB}}$	Output Power at 1 dB Gain Compression ^[2]	f = 1.0 GHz		14.5		
IP_3	Third Order Intercept Point ^[2]	f = 1.0 GHz		25.0		
V_{d}	Device Voltage	V	7.0	7.8	8.6	
dV/dT	Device Voltage Temperature Coefficient	mV/°C		-16.0		

Notes:

1. The recommended operating current range for this device is 25 to 45 mA. Typical performance as a function of current is on the following page.
2. Open loop value. Adding external feedback will alter device performance.

MSA-9970 Typical Scattering Parameters ($Z_0 = 50 \Omega$, $T_A = 25^\circ\text{C}$, $I_d = 35 \text{ mA}$)

Freq. GHz	S_{11}		dB	S_{21}		dB	S_{12}		S_{22}		k
	Mag	Ang		Mag	Ang		Mag	Ang	Mag	Ang	
0.02	.89	-1	17.5	7.51	179	-37.2	.014	4	.93	-1	1.01
0.05	.90	-3	17.5	7.47	177	-35.6	.017	34	.92	-3	.83
0.1	.90	-6	17.4	7.45	174	-33.2	.022	43	.93	-6	.70
0.2	.89	-12	17.4	7.43	168	-29.6	.033	61	.93	-13	.39
0.4	.87	-24	17.2	7.27	156	-24.4	.061	63	.91	-27	.24
0.6	.85	-36	17.0	7.06	145	-20.8	.091	58	.90	-40	.21
0.8	.82	-47	16.6	6.78	134	-18.8	.115	52	.87	-53	.21
1.0	.79	-59	16.2	6.49	124	-17.0	.141	44	.84	-66	.24
1.5	.72	-86	15.3	5.79	100	-14.6	.186	29	.74	-96	.28
2.0	.65	-113	14.2	5.10	77	-13.4	.215	16	.64	-123	.34
2.5	.59	-133	13.0	4.45	61	-12.9	.227	7	.57	-143	.39
3.0	.54	-155	11.6	3.79	42	-12.5	.236	-3	.51	-163	.46
3.5	.53	-174	10.3	3.28	26	-12.4	.239	-14	.45	178	.53
4.0	.52	168	9.2	2.87	10	-12.5	.238	-22	.39	164	.59
4.5	.53	152	8.0	2.51	-4	-12.6	.234	-30	.34	155	.66
5.0	.55	140	6.9	2.21	-17	-12.8	.228	-37	.31	153	.72
5.5	.55	130	5.8	1.94	-31	-13.2	.220	-44	.30	154	.80
6.0	.55	121	4.6	1.70	-43	-13.6	.209	-48	.32	157	.88
6.5	.56	114	3.5	1.50	-53	-13.8	.203	-54	.37	158	.94
7.0	.56	107	2.6	1.34	-63	-14.0	.201	-59	.42	157	.97

Typical Performance, $T_A = 25^\circ\text{C}$

(unless otherwise noted)

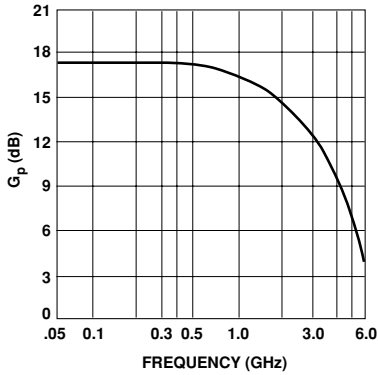

Figure 1. Open Loop Power Gain vs. Frequency, $I_d = 35 \text{ mA}$.

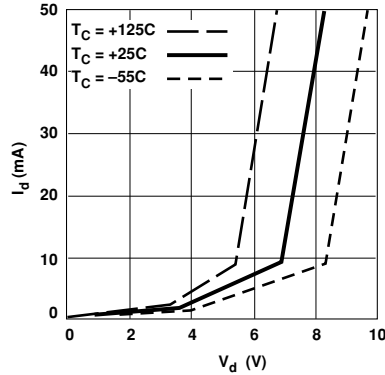

Figure 2. Device Current vs. Voltage.

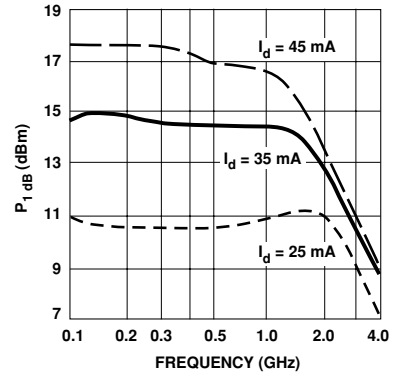

Figure 3. Open Loop Output Power at 1 dB Gain Compression vs. Frequency.

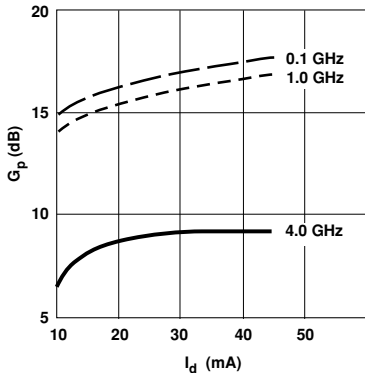

Figure 4. Open Loop Power Gain vs. Current.

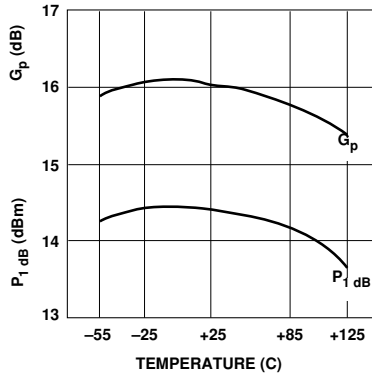
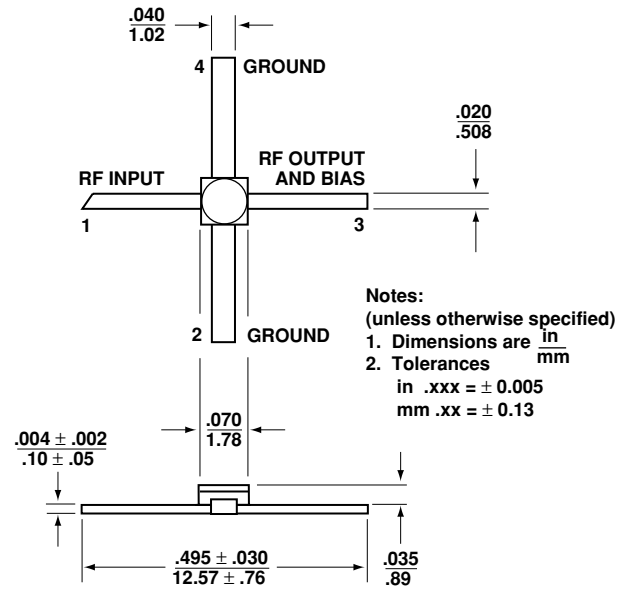

Figure 5. Open Loop Output Power at 1 dB Gain Compression and Open Loop Power Gain vs. Case Temperature, $f = 1.0 \text{ GHz}$, $I_d = 35 \text{ mA}$.

Ordering Information

Part Numbers	No. of Devices	Comments
MSA-9970	100	Bulk

70 mil Package Dimensions



For product information and a complete list of distributors, please go to our web site: www.avagotech.com

Avago, Avago Technologies, and the A logo are trademarks of Avago Technologies, Limited in the United States and other countries. Data subject to change. Copyright © 2008 Avago Technologies, Limited. All rights reserved. Obsoletes 5989-2762EN AV02-1235EN May 15, 2008

AVAGO
TECHNOLOGIES