

MGA-43328

(2.5–2.7) GHz 29dBm High Linearity Wireless Data Power Amplifier



Data Sheet

Description

Avago Technologies' MGA-43328 is a power amplifier for use in the (2.5-2.7)GHz band. High linear output power at 5V is achieved through the use of Avago Technologies' proprietary 0.25um GaAs Enhancement-mode pHEMT process. It is housed in a miniature 5.0mm x 5.0mm x 0.85mm 28-lead QFN package. It also includes shutdown and switchable gain functions. A detector is also included on-chip. The compact footprint coupled with high gain and high efficiency make the MGA-43328 an ideal choice as a power amplifier for IEEE 802.16 (WiMAX) and WLL applications.

Component Image

5.0 x 5.0 x 0.85 mm³ 28-lead QFN Package (Top View)

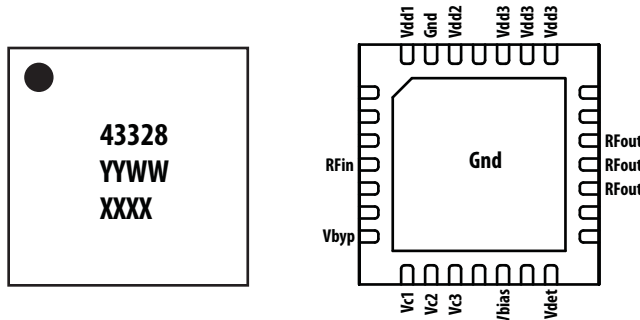

Notes:

Package marking provides orientation and identification

"43328" = Device part number

"YYWW" = Year and work week

"XXXX" = Assembly lot number

Functional Block Diagram

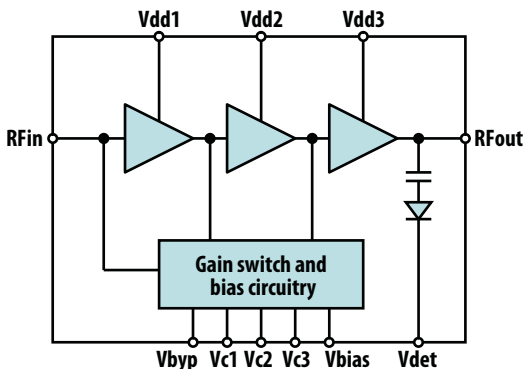

Features

- High gain: 37.3dB
- High linearity performance: 29.3dBm at 5V supply (2.5% EVM, 64-QAM 3/4 FEC rate OFDMA, 10MHz bandwidth)
- High efficiency: 16.6%
- Built-in detector and shutdown switches
- Switchable gain: 24.5dB attenuation using one single CMOS compatible switch pin
- ETSI spectral mask compliant at 29dBm output power
- GaAs E-pHEMT Technology^[1]
- Low cost small package size: 5.0 x 5.0 x 0.85 mm³
- MSL-2a and lead-free
- Usable at 3.3V supply for lower supply voltage applications

Specifications

2.6GHz; Vdd = Vbias = 5.0V, Vc = 2.1V (R2 = 1.0kΩ, R3 = 390Ω, R4 = 1.1kΩ as shown in Figure 36), Iqtotal = 470mA (typ), IEEE 802.16e 64-QAM OFDMA, 3/4 FEC rate

- 37.3 dB Gain
- 29.3 dBm Linear Pout (2.5% EVM)
- 16.6% PAE @ Linear Pout
- 2.6V Vdet @ Linear Pout
- 24.5 dB Switchable Gain Attenuation
- 25μA Shutdown Current

Applications

- High linearity amplifier for IEEE 802.16 fixed terminal amplifier
- WLL amplifier

Note:

1. Enhancement mode technology employs positive Vgs, thereby eliminating the need of negative gate voltage associated with conventional depletion mode devices.

Absolute Maximum Rating^[1] T_A=25°C

Symbol	Parameter	Units	Absolute Max.
V _{dd} , V _{bias}	Supply voltages, bias supply voltage	V	6.0
V _c	Control Voltage	V	(V _{dd})
P _{in,max}	CW RF Input Power	dBm	20
P _{diss}	Total Power Dissipation ^[3]	W	8.0
T _{j,MAX}	Junction Temperature	°C	150
T _{STG}	Storage Temperature	°C	-65 to 150

Thermal Resistance

Thermal Resistance ^[2]

$$\theta_{JB} = 11.7^{\circ}\text{C/W}$$

Notes:

1. Operation of this device in excess of any of these limits may cause permanent damage.
2. Thermal resistance measured using Infra-Red Measurement Technique.
3. Board temperature (T_B) is 25°C, for T_B > 56.4°C derate the device power at 85.5mW per °C rise in board temperature adjacent to package bottom.

Electrical Specifications

T_A = 25°C, V_{dd} = V_{bias} = 5.0V, V_c = 2.1V (R₂ = 1.0kΩ, R₃ = 390Ω, R₄ = 1.1kΩ as shown in Figure 36), V_{byp} = 0V, I_{qtotal} = 470mA, RF performance at 2.6 GHz, IEEE 802.16e 64-QAM, ¾ rate FEC, 10MHz bandwidth OFDMA operation unless otherwise stated.

Symbol	Parameter and Test Condition	Units	Min.	Typ.	Max.
V _{dd}	Supply Voltage	V		5.0	
I _{qtotal}	Quiescent Supply Current (normal high gain mode)	mA		470	
	Quiescent Supply Current (low gain mode, V _{byp} = 5.0V)	mA		470	
Gain	Gain	dB	35.0	37.3	
OP1dB	Output Power at 1dB Gain Compression	dBm		35.5	
P _{out_5V}	Linear Output Power @ 2.5% EVM with 64-QAM OFDMA modulation per IEEE 802.16e specs, 50% duty cycle, ¾ rate FEC	dBm	27.7	29.3	
I _{total_5V}	Total current draw at P _{out_5V} level	mA		1017	1250
S ₁₁	Input Return Loss, 50Ω source	dB		-12	
S ₂₂	Output Return Loss, 50Ω source	dB		-11	
S ₁₂	Reverse Isolation	dB		60	
Atten	Gain attenuation in low gain mode	dB	21.5	24.5	27.5
V _{det}	Detector output DC voltage @ 29dBm linear P _{out}	V		2.6	
DetR	Detector RF dynamic range	dB		10	
NF	Noise figure	dB		2.1	
S	Stability under load VSWR of 6:1 (all phase angle), spurious output	dBc			-60

Product Consistency Distribution Charts^[1]

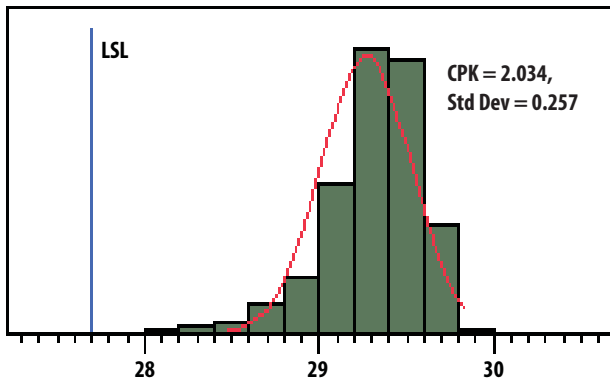

Figure 1. Pout_5V; LSL = 27.7dBm, Nominal = 29.3dBm

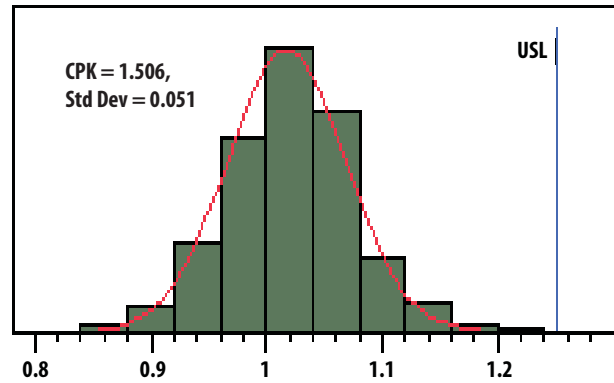

Figure 2. Itotal_5V; Nominal = 1.017A, USL = 1.250A

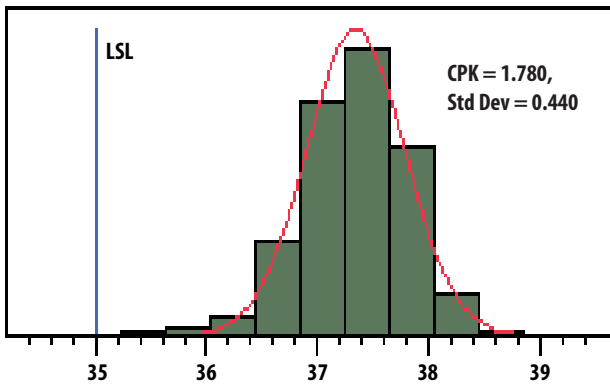

Figure 3. Gain; LSL = 35dB, Nominal = 37.4dB

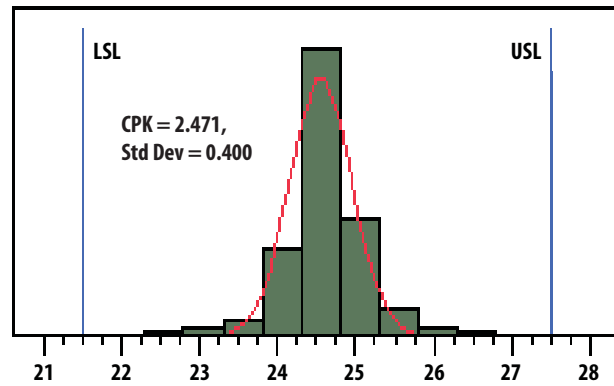

Figure 4. Atten; LSL = 21.5dB, Nominal = 24.6dB, USL = 27.5dB; Vbyp = 5V

Note:

1. Distribution data sample size is 2000 samples taken from 3 different wafer lots. $T_A = 25^\circ\text{C}$, $V_{dd} = V_{bias} = 5\text{V}$, $V_c = 2.1\text{V}$ ($R_2 = 1.0\text{k}\Omega$, $R_3 = 390\Omega$, $R_4 = 1.1\text{k}\Omega$ as shown in Figure 36), $V_{byp} = 0\text{V}$, RF performance at 2.6GHz unless otherwise stated. Future wafers allocated to this product may have nominal values anywhere between the upper and lower limits.

Unless otherwise stated, all modulated signal measurements are made with IEEE 802.16e format as stated in the notes to Figure 36.

MGA-43328 typical over-temperature performance at $V_{dd} = V_{bias} = 5.0V$, $V_c = 2.1V$ ($R_2 = 1.0k\Omega$, $R_3 = 390\Omega$, $R_4 = 1.1k\Omega$ as shown in Figure 36), $V_{byp} = 0V$ unless otherwise stated.

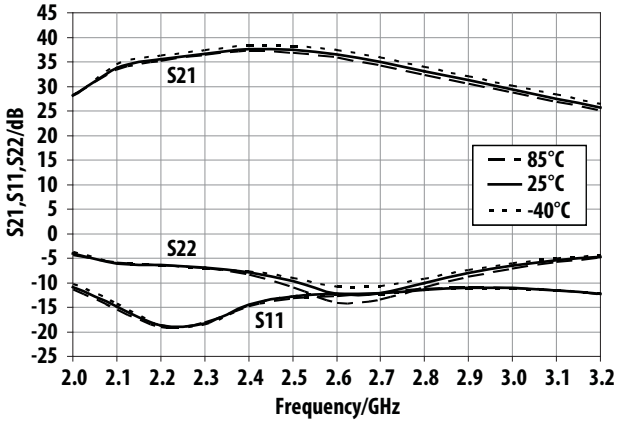

Figure 5. Small-signal performance in high gain mode, $V_{byp} = 0V$

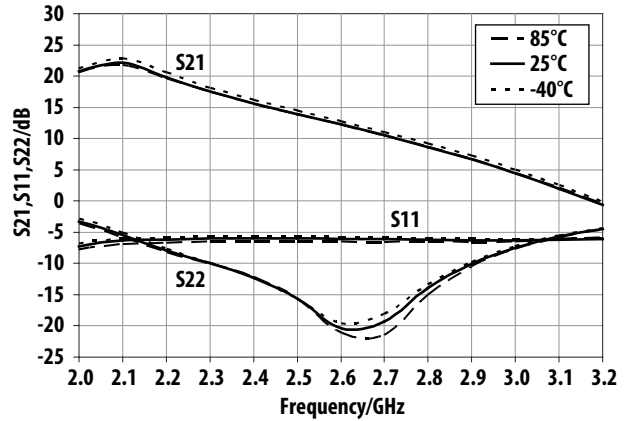

Figure 6. Small-signal performance in low gain mode, $V_{byp} = 5V$

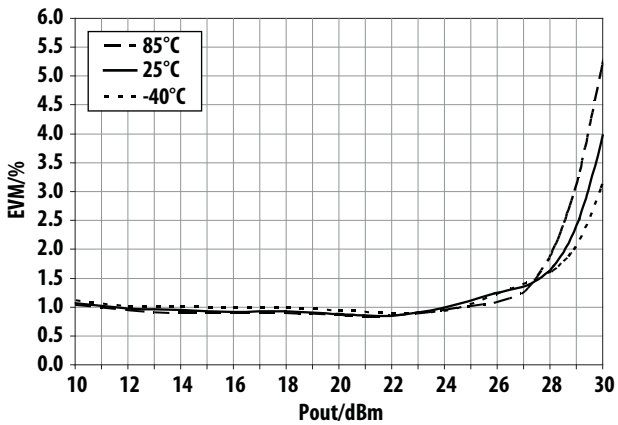

Figure 7. Over-temperature EVM vs Pout @ 2.5GHz

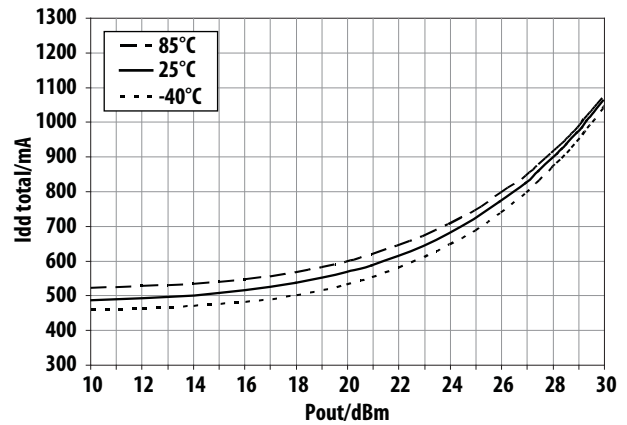

Figure 8. Over-temperature I_{dd_total} vs Pout @ 2.5GHz

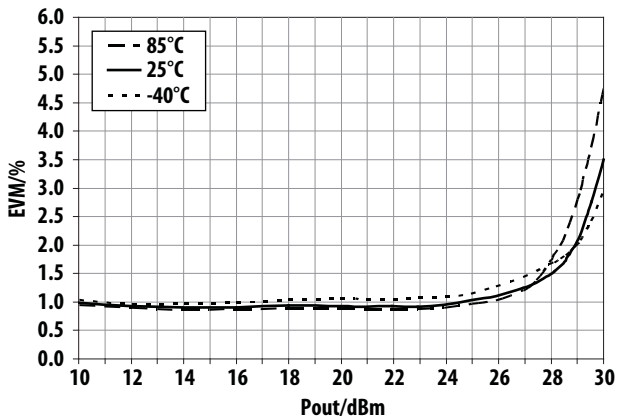

Figure 9. Over-temperature EVM vs Pout @ 2.6GHz

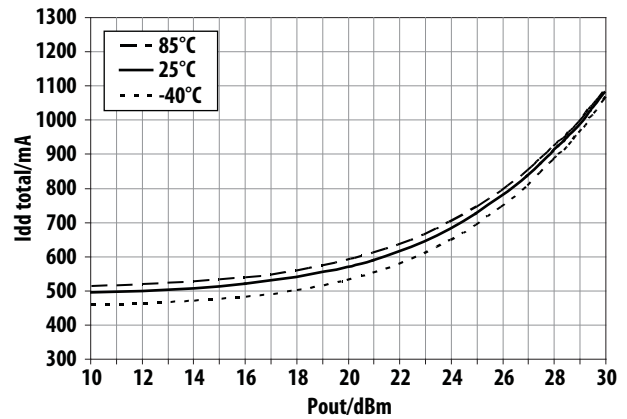

Figure 10. Over-temperature I_{dd_total} vs Pout @ 2.6GHz

MGA-43328 typical over-temperature performance at $V_{dd} = V_{bias} = 5.0V$, $V_c = 2.1V$ ($R_2 = 1.0k\Omega$, $R_3 = 390\Omega$, $R_4 = 1.1k\Omega$ as shown in Figure 36), $V_{byp} = 0V$ unless otherwise stated.

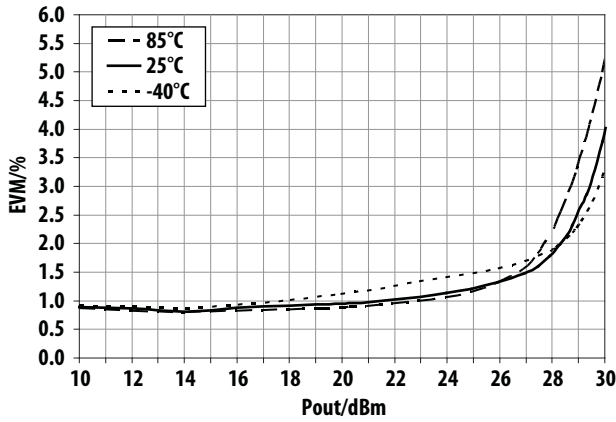

Figure 11. Over-temperature EVM vs Pout @ 2.7GHz

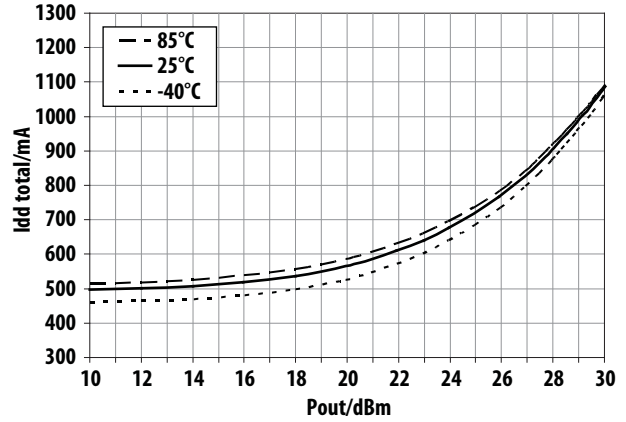

Figure 12. Over-temperature Idd_total vs Pout @ 2.7GHz

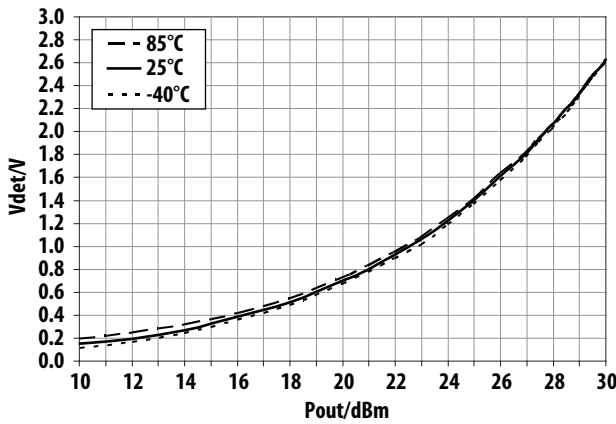

Figure 13. Over-temperature Vdet vs Pout @ 2.5GHz

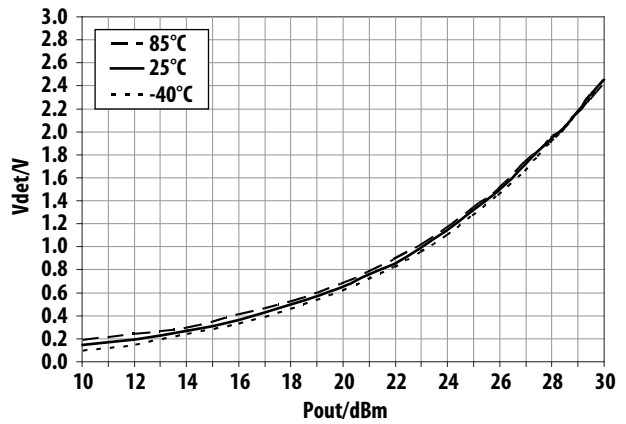

Figure 14. Over-temperature Vdet vs Pout @ 2.6GHz

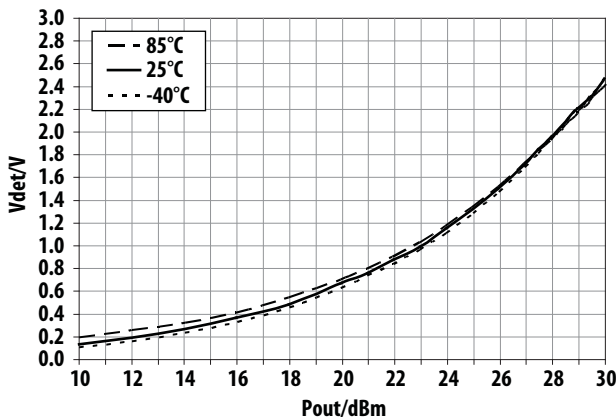

Figure 15. Over-temperature Vdet vs Pout @ 2.7GHz

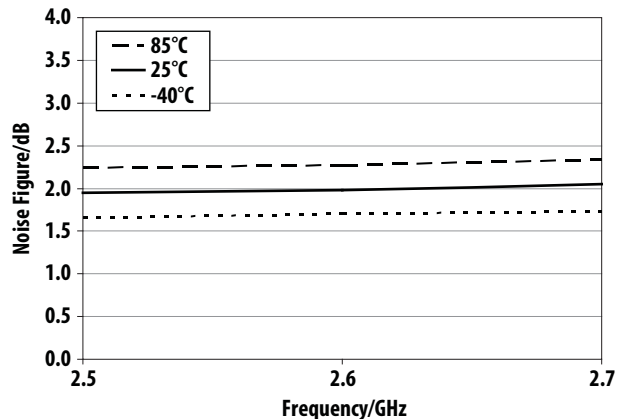

Figure 16. Over-temperature Noise Figure vs Operating Frequency

MGA-43328 typical over-temperature performance at $V_{dd} = V_{bias} = 5.0V$, $V_c = 2.1V$ ($R_2 = 1.0k\Omega$, $R_3 = 390\Omega$, $R_4 = 1.1k\Omega$ as shown in Figure 36), $V_{byp} = 0V$ unless otherwise stated.

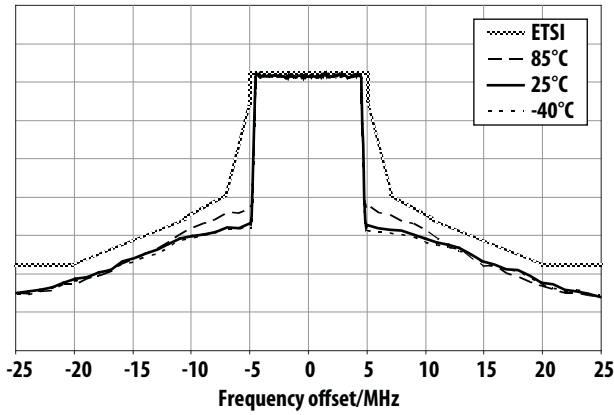

Figure 17. Over-temperature ETSI SEM at 29dBm Pout @ 2.5GHz

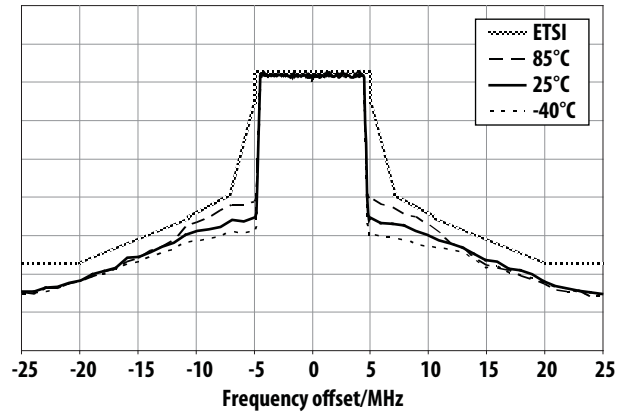

Figure 18. Over-temperature ETSI SEM at 29dBm Pout @ 2.6GHz

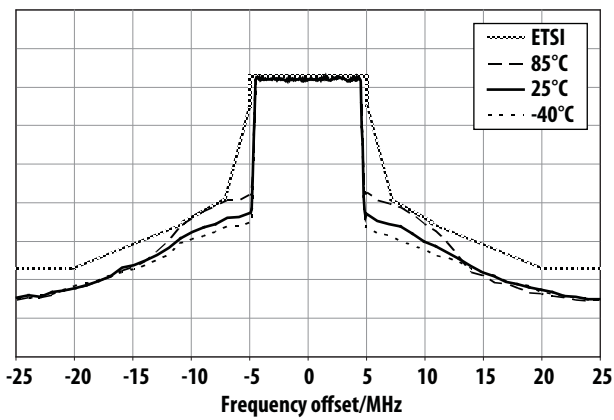

Figure 19. Over-temperature ETSI SEM at 29dBm Pout @ 2.7GHz

MGA-43328 typical over-temperature performance at $V_{dd} = V_{bias} = 3.3V$, $V_c = 2.1V$ ($R_2 = 1.0k\Omega$, $R_3 = 390\Omega$, $R_4 = 1.1k\Omega$ as shown in Figure 36), $V_{byp} = 0V$ unless otherwise stated.

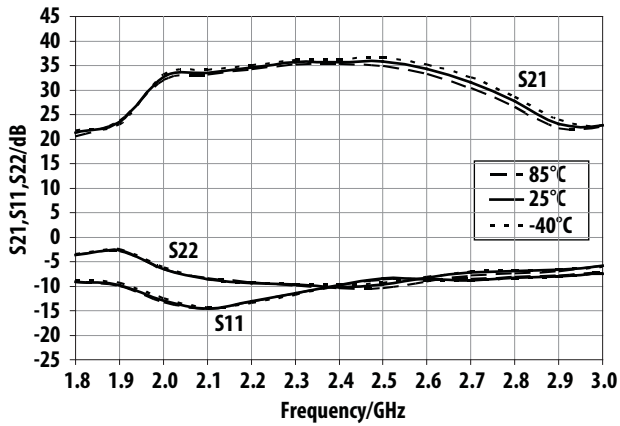

Figure 20. Small-signal performance in high gain mode, $V_{byp} = 0V$

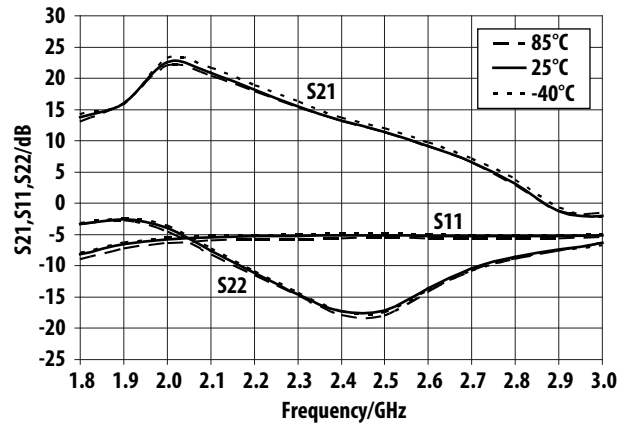

Figure 21. Small-signal performance in low gain mode, $V_{byp} = 3.3V$

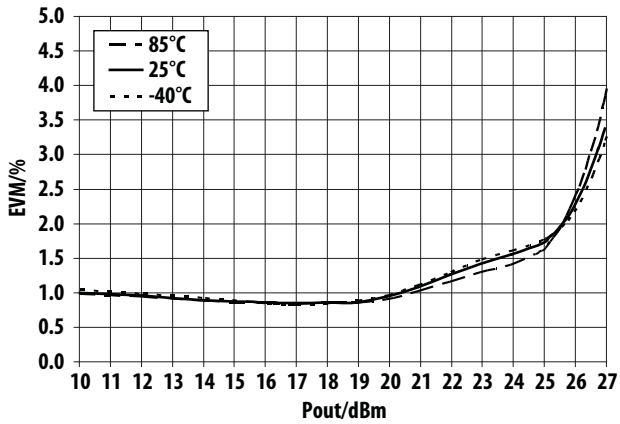

Figure 22. Over-temperature EVM vs Pout @ 2.5GHz

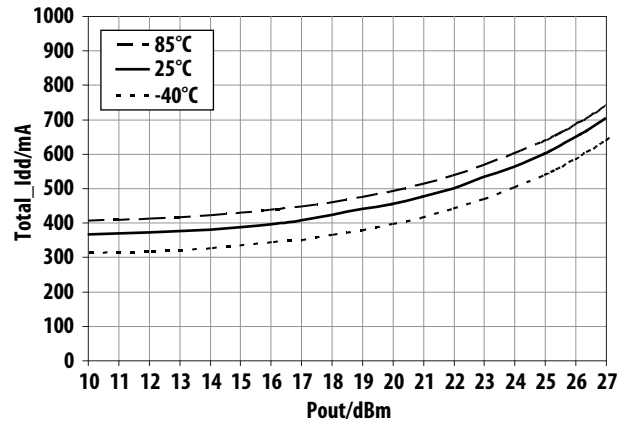

Figure 23. Over-temperature I_{dd_total} vs Pout @ 2.5GHz

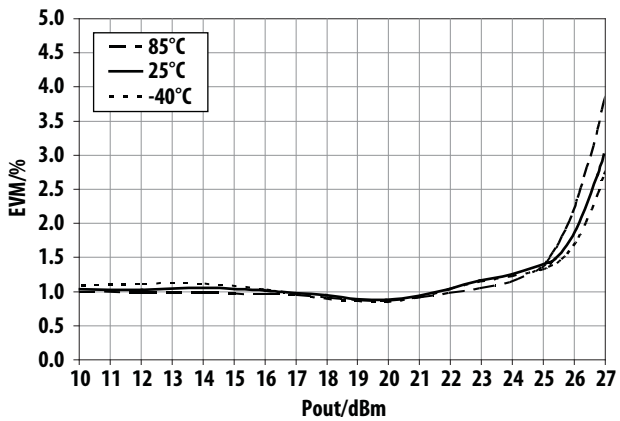

Figure 24. Over-temperature EVM vs Pout @ 2.6GHz

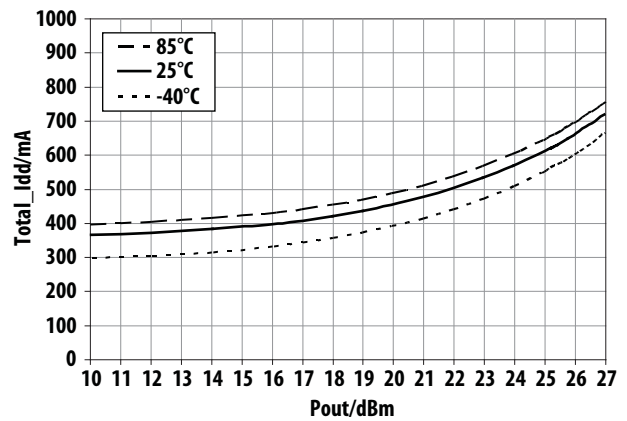

Figure 25. Over-temperature I_{dd_total} vs Pout @ 2.6GHz

MGA-43328 typical over-temperature performance at $V_{dd} = V_{bias} = 3.3V$, $V_c = 2.1V$ ($R_2 = 1.0k\Omega$, $R_3 = 390\Omega$, $R_4 = 1.1k\Omega$ as shown in Figure 36), $V_{byp} = 0V$ unless otherwise stated.

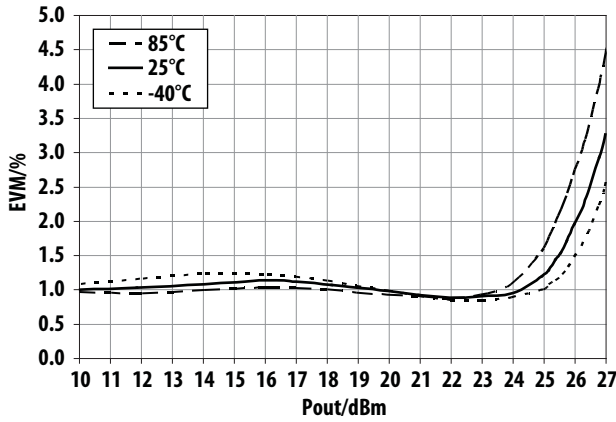

Figure 26. Over-temperature EVM vs Pout @ 2.7GHz

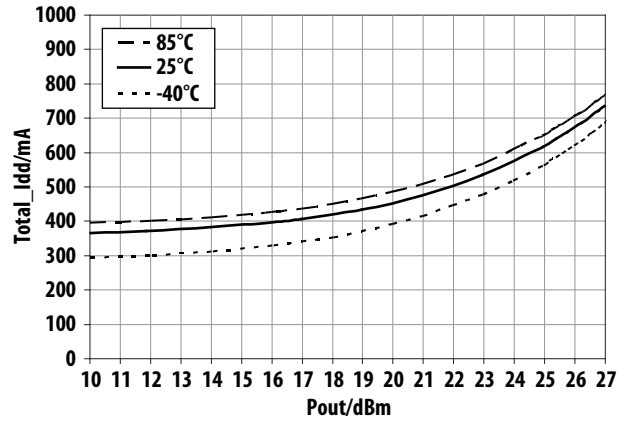

Figure 27. Over-temperature Idd_total vs Pout @ 2.7GHz

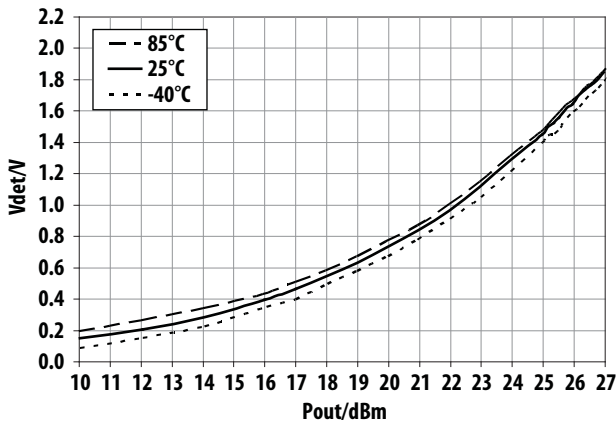

Figure 28. Over-temperature Vdet vs Pout @ 2.5GHz

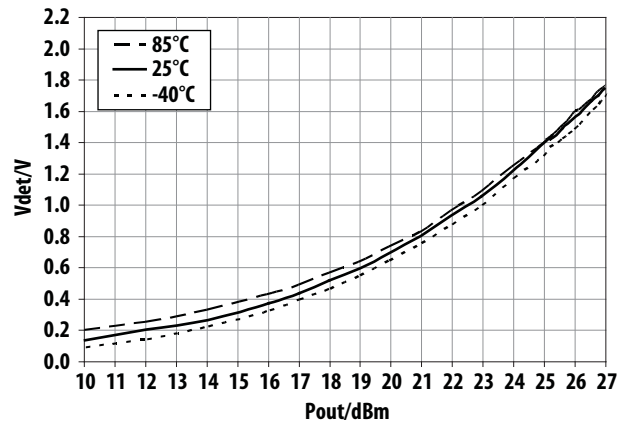

Figure 29. Over-temperature Vdet vs Pout @ 2.6GHz

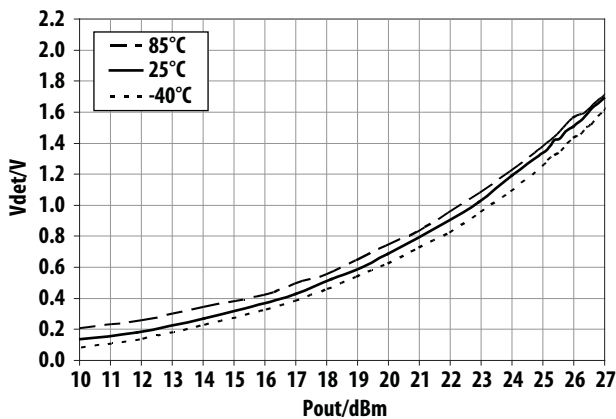

Figure 30. Over-temperature Vdet vs Pout @ 2.7GHz

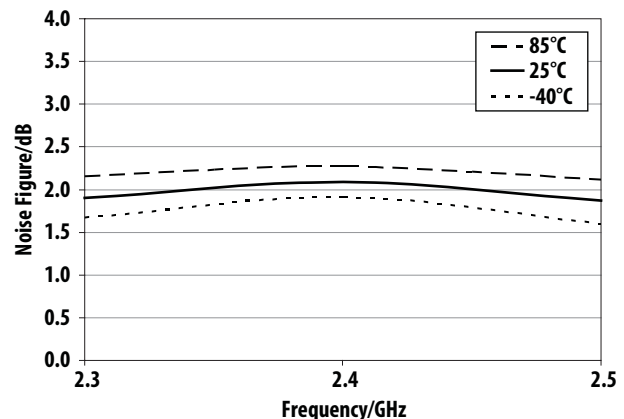

Figure 31. Over-temperature Noise Figure vs Operating Frequency

MGA-43328 typical over-temperature performance at $V_{dd} = V_{bias} = 3.3V$, $V_c = 2.1V$ ($R_2 = 1.0k\Omega$, $R_3 = 390\Omega$, $R_4 = 1.1k\Omega$ as shown in Figure 36), $V_{byp} = 0V$ unless otherwise stated.

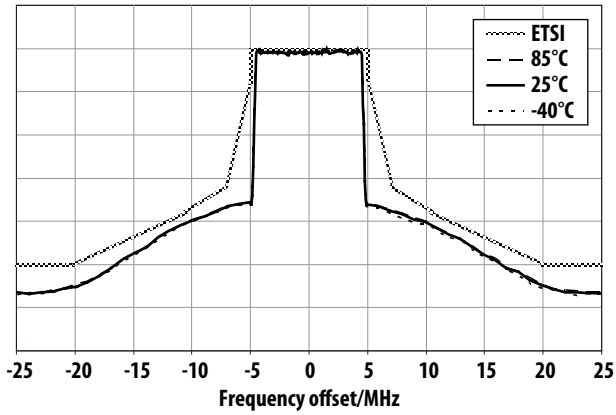

Figure 32. Over-temperature ETSI SEM at 26.5dBm Pout @ 2.5GHz

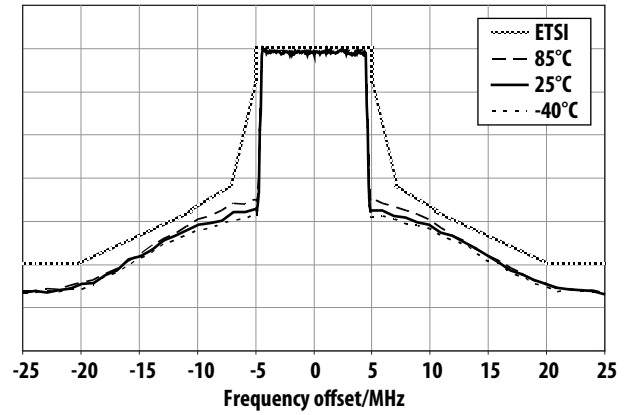

Figure 33. Over-temperature ETSI SEM at 26.5dBm Pout @ 2.6GHz

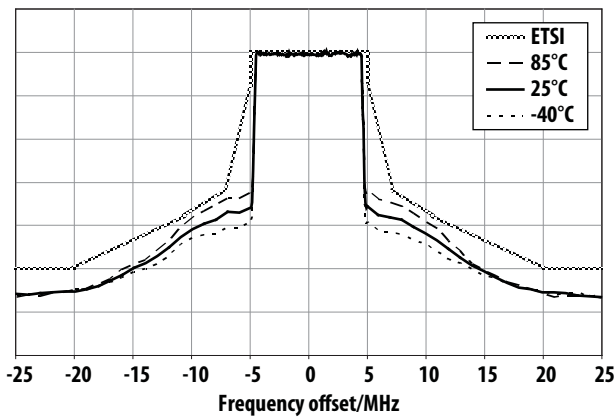

Figure 34. Over-temperature ETSI SEM at 26.5dBm Pout @ 2.7GHz

S-Parameter^[1] (Vdd = Vbias = 5.0V, Vc = 2.1V^[2], Vbyp = 0V, T = 25°C, unmatched)

Freq (GHz)	S11 (dB)	S11 (ang)	S21 (dB)	S21 (ang)	S12 (dB)	S12 (ang)	S22 (dB)	S22 (ang)
0.1	-5.33	174.42	-51.63	-106.16	-66.48	-24.61	-0.26	177.14
0.2	-4.85	164.35	-36.70	-169.58	-64.45	-128.89	-0.48	176.17
0.3	-4.70	152.36	-24.13	134.72	-67.78	144.17	-0.60	175.74
0.4	-4.74	139.79	-14.95	94.41	-70.35	110.18	-0.65	175.26
0.5	-5.18	126.58	-7.84	56.40	-74.22	155.12	-0.70	174.64
0.6	-5.76	112.19	-2.66	20.68	-65.22	105.19	-0.75	173.99
0.7	-6.56	96.27	1.07	-12.51	-69.19	41.83	-0.79	173.36
0.8	-7.62	77.98	3.76	-41.99	-65.34	40.43	-0.82	172.78
0.9	-8.95	55.19	5.80	-68.83	-71.40	-139.14	-0.87	172.21
1.0	-10.51	24.96	7.29	-94.52	-67.35	66.66	-0.91	171.52
1.1	-11.48	-15.20	7.73	-119.97	-74.43	94.40	-0.98	170.63
1.2	-12.65	-71.62	5.26	-141.02	-67.46	99.69	-1.01	170.08
1.3	-10.83	-145.48	3.78	-79.58	-63.64	85.80	-1.04	169.63
1.4	-9.75	122.96	16.71	-102.74	-74.00	91.80	-1.06	169.12
1.5	-12.85	43.85	20.10	-148.54	-68.53	31.18	-1.07	168.64
1.6	-14.67	-20.81	21.23	179.20	-64.86	29.88	-1.08	168.22
1.7	-13.67	-68.50	22.25	151.35	-66.18	128.94	-1.04	168.02
1.8	-12.27	-105.20	22.64	127.87	-68.38	56.24	-0.91	167.46
1.9	-11.19	-134.88	23.30	112.67	-69.99	110.22	-0.68	166.02
2.0	-9.65	-158.85	23.02	114.59	-61.49	55.89	-0.79	161.88
2.1	-9.28	173.54	28.43	81.57	-62.75	121.42	-1.15	161.98
2.2	-9.43	149.47	29.66	43.55	-64.70	67.06	-1.09	162.32
2.3	-9.25	124.71	30.32	14.92	-63.87	73.87	-0.97	161.32
2.4	-9.64	98.43	30.80	-16.12	-64.25	45.79	-0.82	159.64
2.5	-10.14	71.20	30.84	-46.08	-61.78	93.39	-0.76	156.87
2.6	-10.83	43.95	30.48	-75.46	-61.46	107.51	-0.86	154.15
2.7	-11.43	16.68	29.85	-103.66	-57.52	105.76	-1.07	151.65
2.8	-12.11	-10.10	28.94	-130.84	-58.18	114.23	-1.32	149.72
2.9	-12.61	-35.08	27.92	-155.84	-54.03	87.34	-1.59	148.27
3.0	-13.30	-57.98	26.84	179.15	-54.12	77.06	-1.87	147.40
3.1	-14.03	-77.35	25.59	154.96	-53.83	76.33	-2.09	146.98
3.2	-15.00	-92.29	24.23	131.72	-53.48	56.75	-2.24	146.76
3.3	-15.96	-100.94	22.82	109.21	-54.18	54.45	-2.34	146.57
3.4	-16.44	-100.63	21.36	87.09	-54.19	33.91	-2.40	146.36
3.5	-15.57	-96.69	19.88	65.02	-54.14	40.44	-2.45	145.98
3.6	-13.39	-94.57	18.26	42.58	-54.07	18.45	-2.47	145.65
3.7	-10.82	-99.42	16.51	20.04	-58.18	12.66	-2.49	145.18
3.8	-8.50	-108.44	14.55	-2.54	-57.94	31.65	-2.50	144.67
3.9	-6.58	-119.71	12.43	-25.09	-57.65	29.19	-2.56	144.15
4.0	-5.06	-131.79	10.04	-48.15	-59.82	36.94	-2.61	143.96

Freq (GHz)	S11 (dB)	S11 (ang)	S21 (dB)	S21 (ang)	S12 (dB)	S12 (ang)	S22 (dB)	S22 (ang)
4.1	-3.91	-143.66	7.35	-71.61	-60.16	47.28	-2.64	143.94
4.2	-3.07	-154.67	4.13	-96.81	-56.68	30.52	-2.67	143.94
4.3	-2.47	-164.94	-0.60	-124.79	-55.81	33.05	-2.69	143.92
4.4	-2.05	-174.00	-9.54	-139.95	-56.45	20.25	-2.74	144.22
4.5	-1.74	178.05	-13.76	-88.54	-57.51	19.30	-2.77	145.17
4.6	-1.48	171.02	-11.30	-88.58	-57.16	12.42	-2.66	146.33
4.7	-1.28	164.57	-11.69	-101.44	-56.60	4.16	-2.50	146.97
4.8	-1.12	158.68	-12.94	-113.90	-57.64	7.32	-2.31	147.28
4.9	-0.99	153.33	-14.49	-125.76	-57.58	8.26	-2.14	147.17
5.0	-0.87	148.79	-16.27	-137.62	-58.69	4.42	-1.97	147.16
5.1	-0.78	145.16	-18.28	-149.05	-59.27	8.21	-1.84	146.81
5.2	-0.72	140.91	-20.24	-160.85	-60.58	-2.10	-1.76	145.82
5.3	-0.68	136.88	-22.38	-172.76	-59.28	9.87	-1.75	145.19
5.4	-0.64	132.99	-24.87	175.89	-59.34	1.07	-1.66	145.26
5.5	-0.63	129.15	-27.45	167.62	-59.81	-10.36	-1.44	144.51
5.6	-0.62	125.50	-29.69	161.36	-59.09	-11.98	-1.28	143.13
5.7	-0.62	121.98	-31.71	154.89	-60.55	-8.47	-1.17	141.49
5.8	-0.63	118.49	-33.58	148.79	-59.11	6.02	-1.09	139.77
5.9	-0.65	115.01	-35.17	141.47	-62.52	-22.54	-1.03	138.00
6.0	-0.66	111.78	-36.51	134.51	-62.32	-11.27	-1.00	136.12
7.0	-0.71	84.99	-42.36	52.85	-64.07	-20.76	-1.05	117.68
8.0	-0.40	68.30	-43.34	-10.22	-64.63	-0.32	-0.77	108.17
9.0	-0.74	45.03	-46.23	-68.30	-68.21	-38.54	-0.43	100.14
10.0	-1.68	25.05	-49.93	-116.53	-73.37	-75.33	-1.15	86.21
11.0	-0.72	22.88	-59.49	-148.65	-60.85	-25.22	-0.96	64.27
12.0	-0.24	18.09	-64.81	16.64	-58.80	-55.87	-0.65	40.50
13.0	-0.81	7.21	-68.41	-72.54	-60.64	-88.07	-0.74	18.91
14.0	-0.69	-13.10	-64.23	-66.26	-61.26	-68.43	-0.84	-3.81
15.0	-0.32	-28.95	-60.89	-80.11	-60.74	-93.63	-1.08	-29.39
16.0	-0.30	-36.77	-60.25	-71.49	-62.24	-60.19	-1.06	-56.31
17.0	-0.40	-40.51	-58.99	-83.95	-58.02	-72.99	-0.74	-76.53
18.0	-0.44	-43.97	-59.34	-100.47	-56.07	-109.59	-0.73	-89.40
19.0	-0.58	-55.01	-53.61	-122.26	-55.39	-133.57	-0.98	-108.88
20.0	-0.79	-75.48	-55.74	-176.39	-56.19	-160.23	-0.97	-134.29

Notes:

1. S-parameter is measured with deembedded reference plane at DUT RFin and RFout pins.
2. R2 = 1.0k Ω , R3 = 390 Ω , R4 = 1.1k Ω as shown in Figure 36.

S-Parameter^[1] (V_{dd} = V_{bias} = 3.3V, V_c = 2.1V^[2], V_{byp} = 0V, T = 25°C, unmatched)

Freq (GHz)	S11 (dB)	S11 (ang)	S21 (dB)	S21 (ang)	S12 (dB)	S12 (ang)	S22 (dB)	S22 (ang)
0.1	-5.27	173.78	-50.82	-107.10	-56.86	-141.67	-0.25	177.21
0.2	-4.88	163.59	-37.81	-165.73	-73.20	176.22	-0.47	176.18
0.3	-4.74	151.80	-25.10	138.11	-70.13	74.46	-0.60	175.71
0.4	-4.84	139.48	-16.01	96.51	-70.25	137.15	-0.66	175.30
0.5	-5.24	126.53	-8.96	58.55	-68.27	100.20	-0.72	174.82
0.6	-5.84	112.47	-3.79	22.34	-72.81	-68.46	-0.76	174.26
0.7	-6.60	96.97	-0.08	-10.79	-67.56	16.26	-0.81	173.69
0.8	-7.56	78.95	2.66	-40.12	-69.46	80.94	-0.85	173.14
0.9	-8.75	56.81	4.70	-67.16	-72.58	61.15	-0.90	172.55
1.0	-10.06	27.31	6.25	-92.61	-74.11	127.16	-0.94	171.88
1.1	-11.12	-12.96	6.85	-119.56	-62.35	95.15	-1.01	171.03
1.2	-12.78	-67.80	4.44	-141.48	-68.51	72.98	-1.04	170.51
1.3	-11.13	-141.48	2.49	-81.00	-64.40	89.90	-1.08	170.03
1.4	-10.04	126.71	15.56	-100.72	-66.50	42.73	-1.10	169.55
1.5	-12.88	42.43	18.99	-146.97	-65.58	56.49	-1.11	169.11
1.6	-13.80	-25.73	19.96	179.63	-70.10	144.11	-1.10	168.69
1.7	-13.23	-71.73	20.99	156.36	-69.56	47.50	-1.06	168.35
1.8	-11.64	-105.30	21.84	132.62	-64.80	126.19	-0.93	167.80
1.9	-10.67	-132.11	23.20	108.71	-69.85	145.85	-0.68	166.48
2.0	-9.16	-156.02	21.74	106.84	-66.29	96.90	-0.78	162.51
2.1	-8.78	176.45	26.92	80.34	-61.03	69.10	-1.08	162.75
2.2	-8.53	152.97	28.53	49.69	-68.82	78.81	-1.02	162.31
2.3	-8.73	127.19	29.41	15.78	-66.69	74.45	-0.92	161.61
2.4	-9.12	101.12	29.75	-14.41	-61.39	95.04	-0.78	159.84
2.5	-9.66	73.79	29.83	-43.95	-63.37	109.79	-0.71	157.42
2.6	-10.42	46.13	29.56	-73.38	-63.49	108.06	-0.80	154.75
2.7	-11.25	19.02	28.92	-101.99	-61.77	125.22	-0.98	152.46
2.8	-11.87	-7.44	27.99	-128.53	-57.49	107.56	-1.18	150.66
2.9	-12.47	-31.77	27.05	-153.50	-58.45	78.50	-1.41	149.10
3.0	-13.02	-54.87	26.03	-178.46	-54.09	83.88	-1.67	148.21
3.1	-13.74	-74.46	24.82	157.39	-54.80	64.36	-1.85	147.59
3.2	-14.63	-90.10	23.54	133.95	-54.16	59.56	-2.02	147.26
3.3	-15.60	-99.03	22.14	111.06	-53.44	57.92	-2.12	147.06
3.4	-16.07	-100.28	20.68	89.04	-55.47	30.67	-2.16	146.54
3.5	-15.56	-96.72	19.33	66.76	-53.45	33.40	-2.24	146.18
3.6	-13.50	-93.83	17.73	43.77	-57.14	25.67	-2.27	145.72
3.7	-10.92	-97.66	16.01	20.84	-55.67	18.84	-2.32	145.24
3.8	-8.51	-106.48	14.05	-2.30	-58.37	33.62	-2.35	144.71
3.9	-6.54	-118.04	11.87	-25.24	-58.85	36.80	-2.41	144.09
4.0	-5.03	-130.40	9.46	-48.02	-58.10	45.27	-2.49	143.79

Freq (GHz)	S11 (dB)	S11 (ang)	S21 (dB)	S21 (ang)	S12 (dB)	S12 (ang)	S22 (dB)	S22 (ang)
4.1	-3.88	-142.30	6.88	-71.55	-57.42	30.45	-2.55	143.64
4.2	-3.01	-153.64	3.71	-97.80	-57.45	44.42	-2.60	143.57
4.3	-2.41	-164.09	-1.04	-127.36	-57.13	31.20	-2.65	143.57
4.4	-2.00	-173.45	-10.56	-143.61	-55.64	28.66	-2.75	143.83
4.5	-1.70	178.50	-14.46	-88.81	-56.05	26.87	-2.77	144.91
4.6	-1.44	171.23	-12.27	-89.28	-56.35	9.18	-2.65	145.82
4.7	-1.26	164.59	-12.70	-100.55	-56.98	18.34	-2.51	146.28
4.8	-1.10	158.61	-13.78	-111.54	-56.59	12.38	-2.34	146.52
4.9	-0.98	153.04	-15.07	-123.02	-58.04	10.73	-2.17	146.36
5.0	-0.86	148.57	-16.64	-135.24	-57.96	-2.10	-2.02	146.42
5.1	-0.77	144.90	-18.51	-147.83	-59.32	1.71	-1.90	146.29
5.2	-0.72	140.60	-20.44	-160.69	-61.73	4.47	-1.80	145.20
5.3	-0.68	136.50	-22.59	-174.20	-59.56	17.23	-1.80	144.59
5.4	-0.66	132.50	-25.15	174.11	-60.60	-6.37	-1.70	144.52
5.5	-0.65	128.72	-27.77	165.02	-57.14	2.60	-1.47	143.93
5.6	-0.65	125.04	-30.12	158.54	-60.63	-14.76	-1.29	142.51
5.7	-0.65	121.38	-32.22	152.04	-60.41	-6.39	-1.16	140.85
5.8	-0.65	117.87	-34.04	146.12	-60.29	1.46	-1.06	139.25
5.9	-0.66	114.48	-35.84	138.92	-61.54	-2.93	-0.96	137.58
6.0	-0.68	111.12	-37.36	132.41	-61.33	1.14	-0.89	135.78
7.0	-0.64	84.53	-42.61	50.65	-61.23	-14.97	-0.49	118.93
8.0	-0.30	67.93	-44.61	-16.17	-65.17	-33.77	-0.38	108.62
9.0	-0.73	44.80	-46.18	-68.02	-61.23	-35.14	-0.44	99.21
10.0	-1.33	25.34	-49.18	-124.64	-69.79	-92.38	-0.57	80.06
11.0	-0.40	20.45	-57.26	-167.22	-67.21	15.19	-0.65	59.36
12.0	-0.18	16.10	-64.91	-59.04	-61.32	-71.26	-0.70	38.96
13.0	-0.78	2.29	-68.22	-78.01	-64.20	-79.92	-0.78	13.60
14.0	-0.69	-16.74	-63.09	-65.82	-64.81	-53.57	-0.84	-8.84
15.0	-0.31	-29.38	-61.98	-86.37	-63.51	-91.57	-1.09	-30.94
16.0	-0.42	-40.34	-60.89	-63.40	-58.98	-63.43	-1.39	-61.01
17.0	-0.63	-47.92	-58.15	-90.09	-59.51	-98.33	-1.05	-82.43
18.0	-0.49	-48.13	-58.40	-107.96	-58.49	-119.69	-0.72	-91.79
19.0	-0.63	-56.79	-56.09	-142.95	-56.48	-139.82	-1.17	-109.91
20.0	-1.54	-78.66	-54.09	-172.59	-54.67	-164.45	-1.38	-137.33

Notes:

1. S-parameter is measured with deembedded reference plane at DUT RFin and RFout pins.
2. R2 = 1.2k Ω , R3 = 300 Ω , R4 = 1.2k Ω as shown in Figure 36.

Demonstration Board Top View

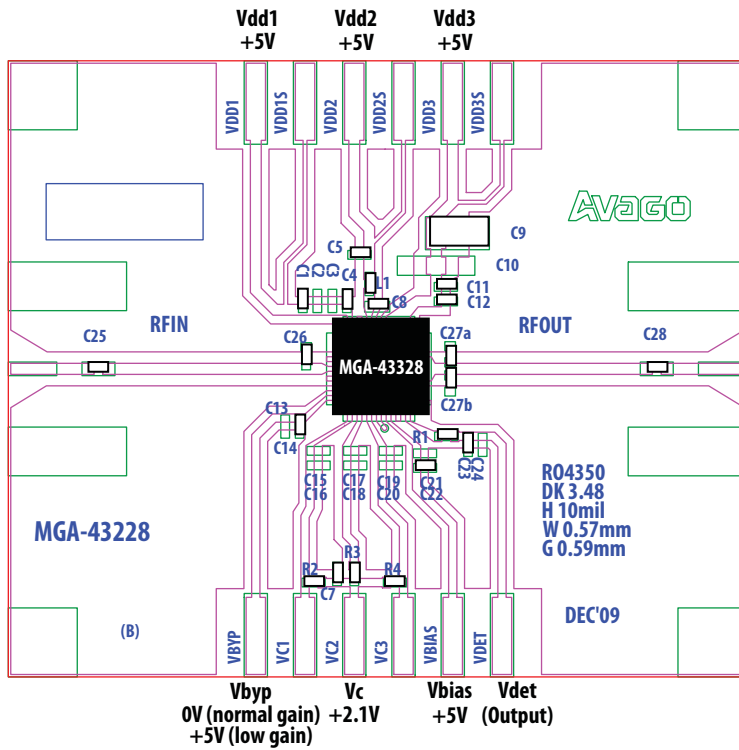

Bill of materials

Component	Value	Part #
C9	22uF	GRM31CR61C226ME15
C1, C5, C11, C22	0.1uF	GRM155R71C104KA88
C4, C7, C13, C21, C25, C28	7.5pF	GJM1555C1H7R5DB01
C8	0.8pF	GJM1555C1HR80BB01
C12	1.6pF	GJM1555C1H1R6CB01
C26	0.3pF	GJM1555C1HR30BB01
C27a	1.8pF	GJM1555C1H1R8CB01
C27b	2.0pF	GJM1555C1H2R0CB01
C23	22nF	GRM155R71E223KA61
L1	3.3nH	0402HP-3N3XJLW
R1	0Ω	RK73Z1ETTD
R2	1.0kΩ	RK73B1ETTD102J
R3	390Ω	RK73B1ETTD391J
R4	1.1kΩ	RK73B1ETTD112J

Note:

For performance optimization, control voltage for individual stages can be adjusted by varying R2, R3 and R4 resistor values.

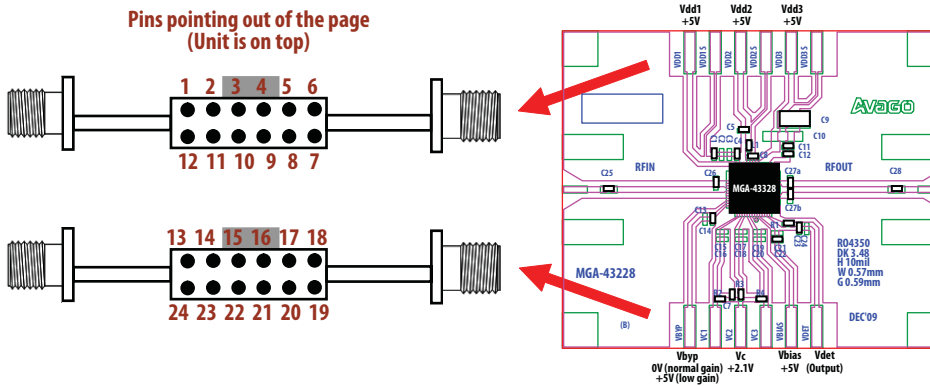

Application board pin header assignments

- Pin 1 : Vdd3 (Sense)
 - Pin 2 : Vdd3 (Force)
 - Pin 3 : Vdd2 (Sense)
 - Pin 4 : Vdd2 (Force)
 - Pin 5 : Vdd1 (Sense)
 - Pin 6 : Vdd1 (Force)
 - Pin 13 : Vbyp
 - Pin 14 : Vc1 (Not used)
 - Pin 15 : Vc2
 - Pin 16 : Vc3 (Not used)
 - Pin 17 : Vbias
 - Pin 18 : Vdet
- Other pins are grounded*

Figure 35. Demonstration board application circuit for MGA-43328 module

Application Schematic

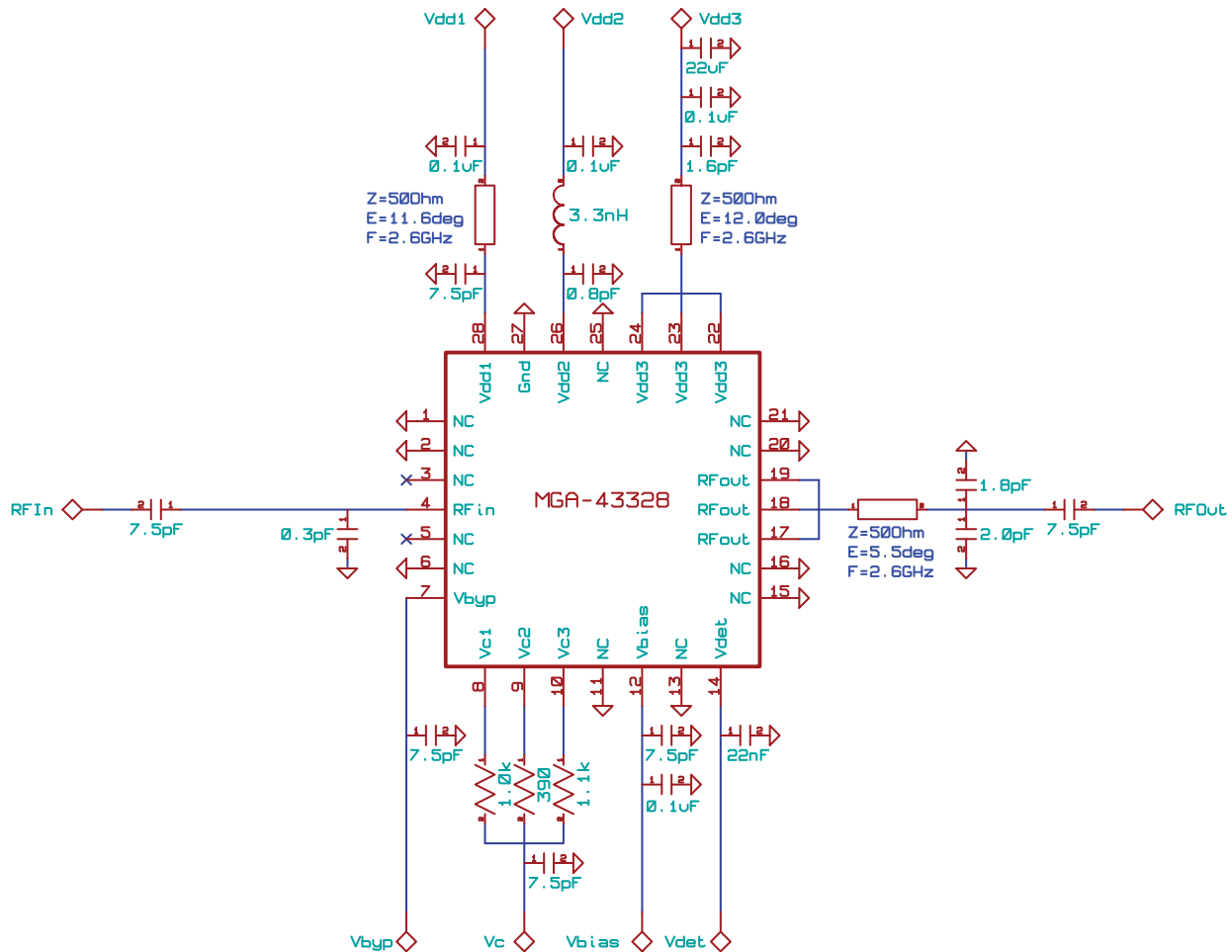
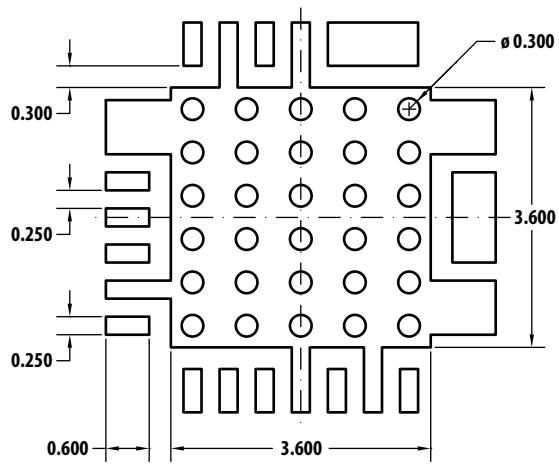

Figure 36. Application schematic in demonstration board

Notes:

- In normal gain mode operation, Vbyp = 0V. Vc1, Vc2 and Vc3 are bias pins that are used to set the bias conditions to the 3 internal gain stages of the PA.
- Typical quiescent current distribution with Vdd1 = Vdd2 = Vdd3 = Vbias = 5V, Vbyp = 0V, Vc = 2.1V is :
 - I_{dd1} = 55.5 mA
 - I_{dd2} = 146 mA
 - I_{dd3} = 268.5 mA
 - I_{bias} = 16.5mA
 (Note: Vc supplied through Vc2 pin on demonstration board with R₂ = 1.0kΩ, R₃ = 390Ω and R₄ = 1.1kΩ)
- Low gain mode is enabled by setting Vbyp pin to 5V. This condition overrides the normal high gain mode operation and bypasses the first gain stage, regardless of the voltage at Vc1 pin.
- Modulated signal measurements are made with Agilent 89600 VSA and Agilent E4438C signal generator with IEEE 802.16e option using the following test conditions :
 - Signal format: IEEE 802.16e OFDMA, ¾ rate FEC
 - Modulation: 64-QAM
 - Number of Subcarriers: 840
 - Modulation bandwidth: 10 MHz
 - Downlink ratio: 50%
 Residual distortion of signal generator: (0.6-0.8)%. This distortion is not removed from the overall EVM data in the datasheet.
- Typical operating voltages and currents:
 - Normal gain mode : Vdd1 = Vdd2 = Vdd3 = Vbias = 5V. Vc = 2.1V. Vbyp = 0V. I_q(total) = 470 mA.
 - Low gain mode : Vdd1 = Vdd2 = Vdd3 = Vbias = 5V. Vc = 2.1V. Vbyp = 5V. I_q(total) = 470 mA.
- Vdd1/2/3 are shown as separate supplies with individual bypass capacitors. This yields the most stable configuration. If a common power supply line is used, proper broadband bypass decoupling is recommended to reduce common mode feedback through the supply line.

PCB Land Pattern and Stencil Outline



PCB Land Pattern (Top View)

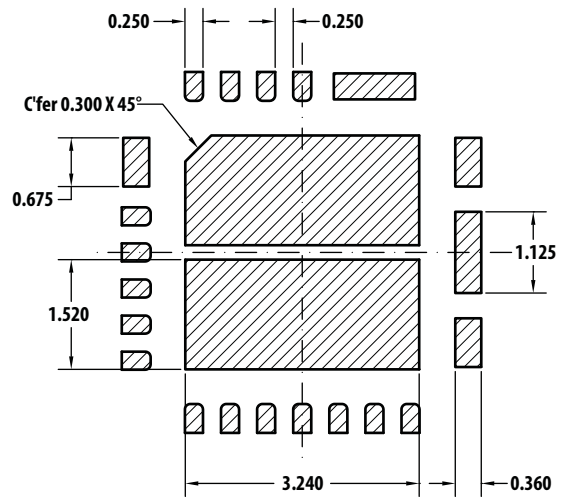

Stencil Outline

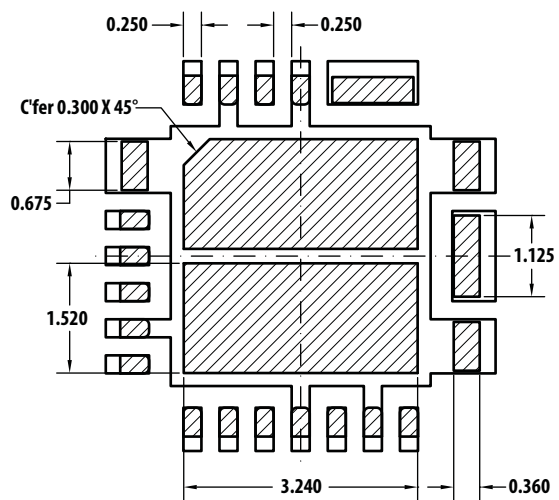

Combined PCB Land Pattern and Stencil Outline

(All dimensions in mm)

Device Orientation

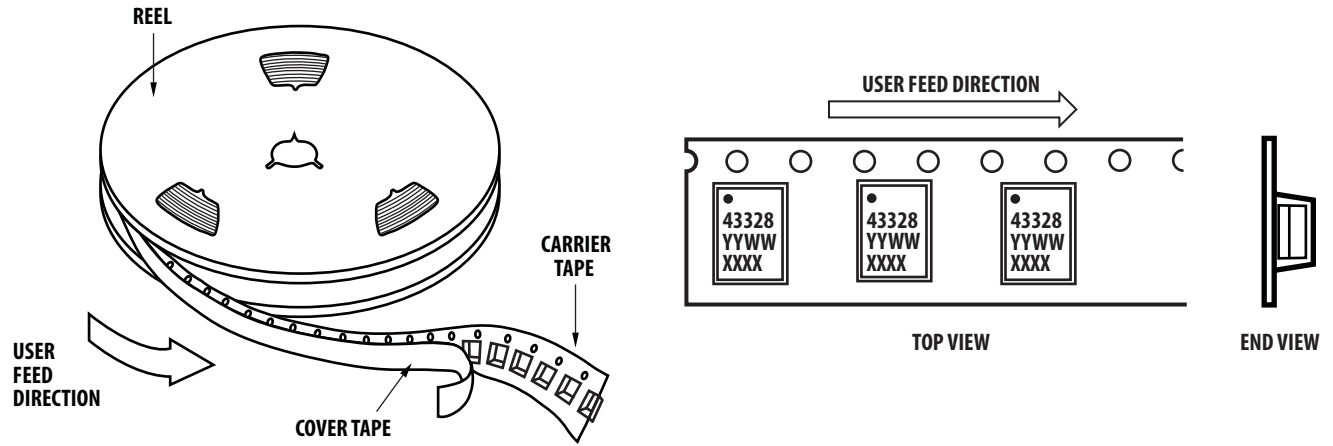

Tape Dimensions

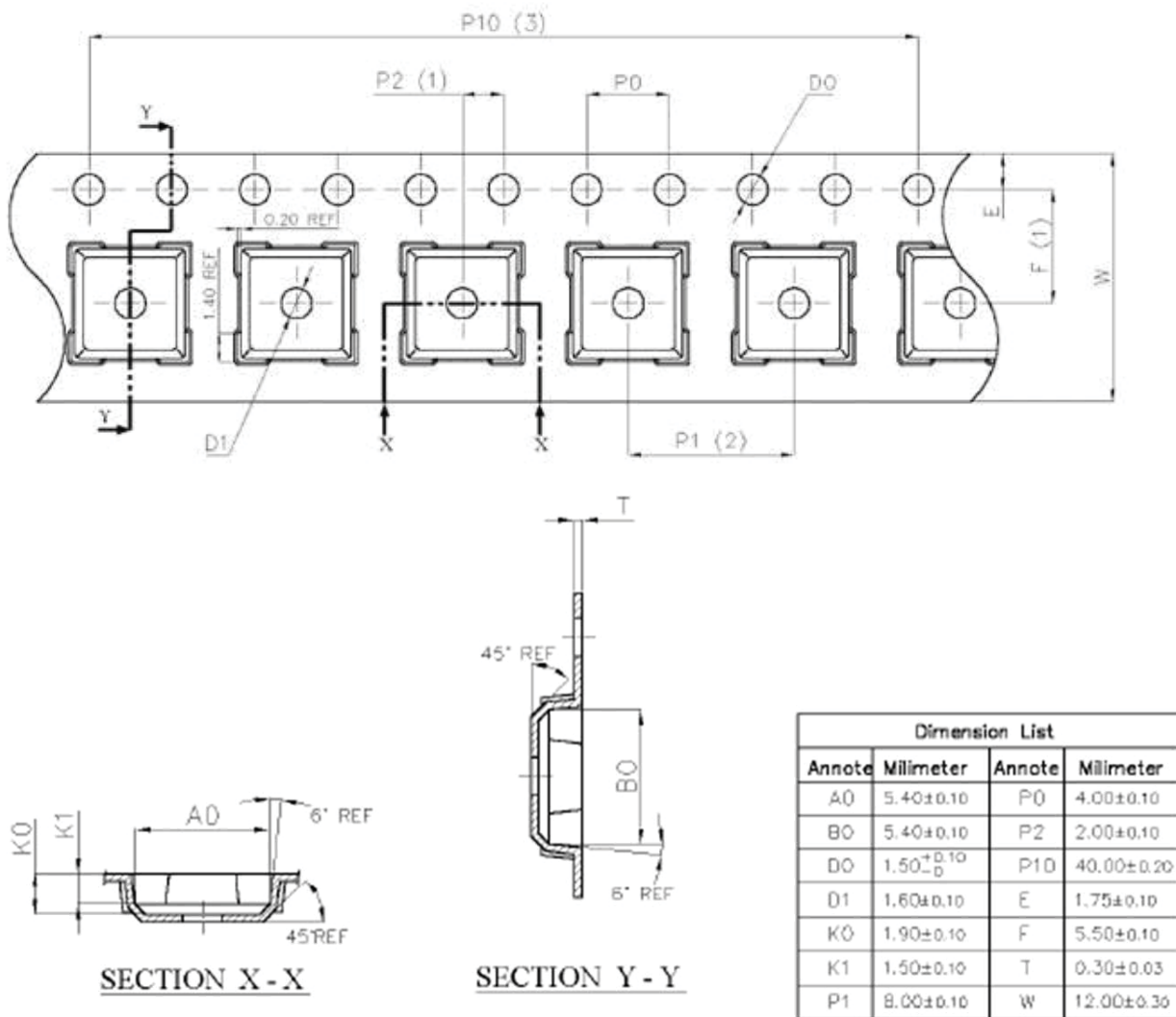

Reel Dimensions (7" reel)

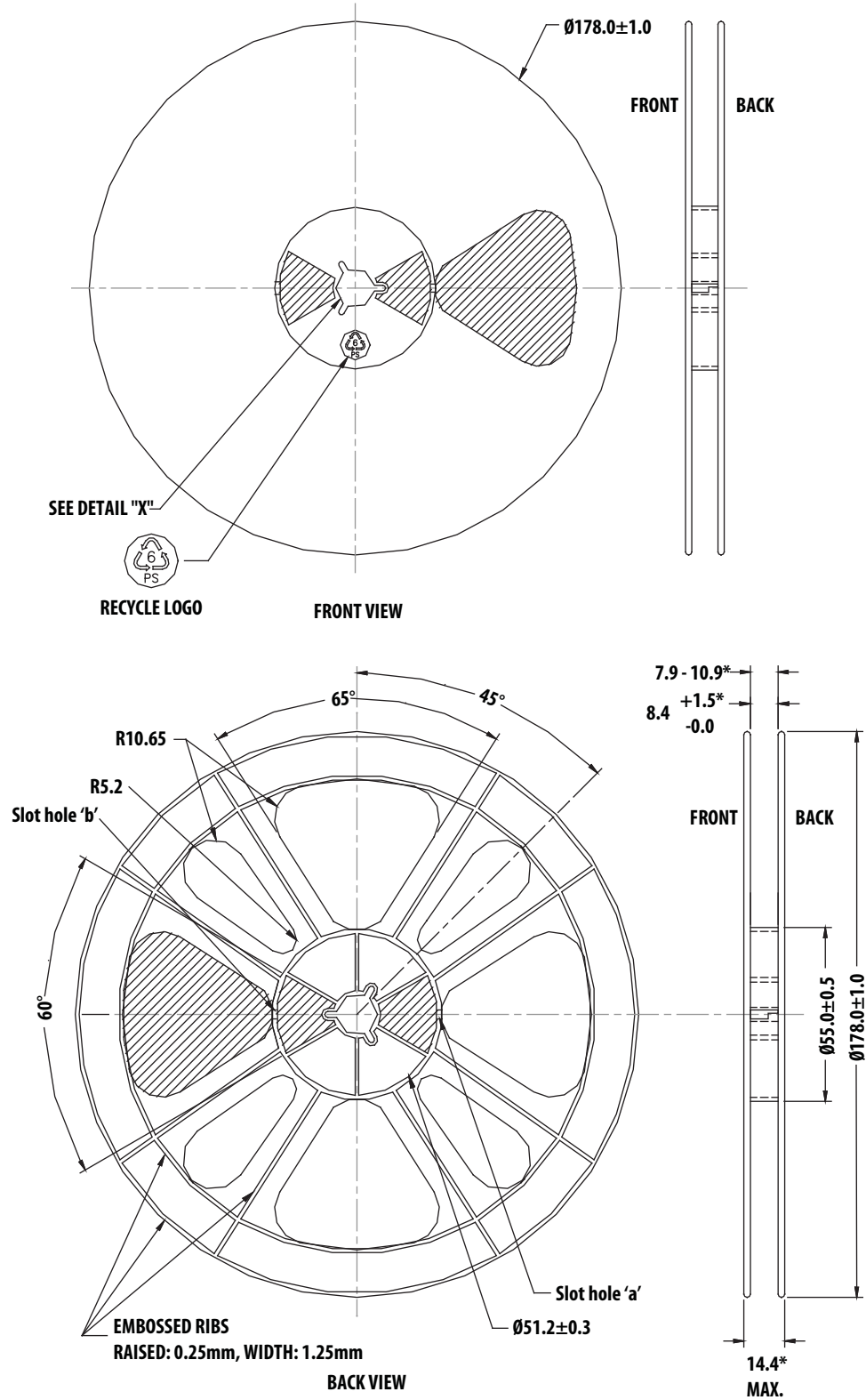

For product information and a complete list of distributors, please go to our web site: www.avagotech.com

Avago, Avago Technologies, and the A logo are trademarks of Avago Technologies in the United States and other countries. Data subject to change. Copyright © 2005-2010 Avago Technologies. All rights reserved. AV02-2356EN - March 4, 2010

