

# Data Sheet

## Description

Avago Technologies' ALM-2712 is an ultra low-noise GPS front-end module that combines a low-noise amplifier (LNA) with GPS FBAR filters. The LNA uses Avago Technologies' proprietary GaAs Enhancement-mode pHEMT process to achieve high gain with very low noise figure and high linearity. Noise figure distribution is very tightly controlled. A CMOS-compatible shutdown pin is included either for turning the LNA on/off, or for current adjustment. The integrated filter utilizes an Avago Technologies' leading-edge FBAR filter for exceptional rejection at Cellular, DCS, PCS and WLAN band frequencies. Bypass functionality with an external RF switch is possible with separate RF switching.

The low noise figure and high gain, coupled with low current consumption make it suitable for use in critical low-power GPS applications or during low-battery situations.

## Component Image

Surface Mount (3.0 x 2.5 x 1) mm<sup>3</sup> 12-lead MCOB

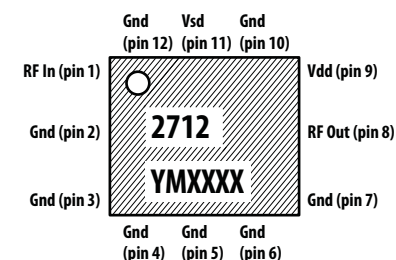

TOP VIEW

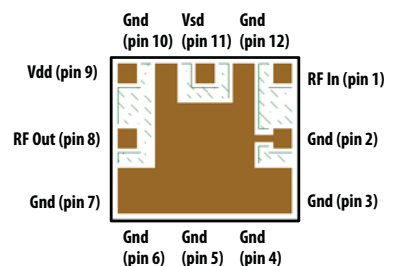

BOTTOM VIEW

Note:  
Package marking provides orientation and identification  
"2712" = Product Code  
"Y" = Year of manufacture  
"M" = Month of manufacture  
"XXXX" = Last 4 digit of lot number

## Features

- Very Low Noise Figure: 1.26 dB typ.
- Exceptional Cell/DCS/PCS/WLAN-Band rejection
- Advanced GaAs E-pHEMT & FBAR Technology
- Low external component count.
- CMOS compatible shutdown pin (SD)
- ESD: > 3kV at RFin pin
- Adjustable bias current via single external resistor/voltage
- Useable down to 1.8V supply voltage
- Small package dimension: 3.0(L)x2.5(W)x1(H) mm<sup>3</sup>
- Meets MSL3, Lead-free and halogen free

## Specifications (Typical performance @ 25°C)

At 1.575GHz, Vdd = 2.7V, Idd = 7.5mA

- Gain = 14.2 dB
- NF = 1.26 dB
- IIP3 = +5 dBm, IP1dB = +2 dBm
- S11 = -9 dB, S22 = -12 dB
- Low-Band Rejection (824 – 928MHz): 89 dBc
- High-Band Rejection (1710 – 1980MHz): 80 dBc
- WLAN-Band Rejection (2400 – 2500MHz): 72 dBc

## Application

- GPS Front-end Module

## Application Circuit

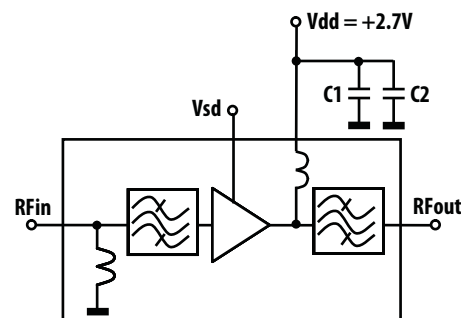

**Attention: Observe precautions for handling electrostatic sensitive devices.**

RF In (Pin 1) to GND: ESD Human Body Model = 3 kV  
All other Pins : ESD Machine Model = 50 V  
: ESD Human Body Model = 300 V

Refer to Avago Application Note A004R:  
Electrostatic Discharge, Damage and Control.

## Absolute Maximum Rating<sup>[1]</sup> T<sub>A</sub>=25°C

Symbol	Parameter	Units	Absolute Max.
V <sub>dd</sub>	Device Drain to Source Voltage <sup>[2]</sup>	V	3.6
I <sub>dd</sub>	Drain Current <sup>[2]</sup>	mA	20
P <sub>in,max</sub>	CW RF Input Power (V <sub>dd</sub> = 2.7V, I <sub>dd</sub> = 7.5mA)	dBm	15
P <sub>diss</sub>	Total Power Dissipation <sup>[4]</sup>	mW	72
T <sub>j</sub>	Junction Temperature	°C	150
T <sub>STG</sub>	Storage Temperature	°C	-65 to 150

## Thermal Resistance<sup>[3]</sup>

(V<sub>dd</sub> = 2.7V, I<sub>dd</sub> = 7.5mA), θ<sub>jc</sub> = 92°C/W

Notes:

1. Operation of this device in excess of any of these limits may cause permanent damage.
2. Assuming DC quiescent conditions.
3. Thermal resistance measured using Infra-Red measurement technique.
4. Board (module belly) temperature T<sub>B</sub> is 25°C. Derate 10.87 mW/°C for T<sub>B</sub>>143°C.

## Product Consistency Distribution Charts<sup>[5,6]</sup>

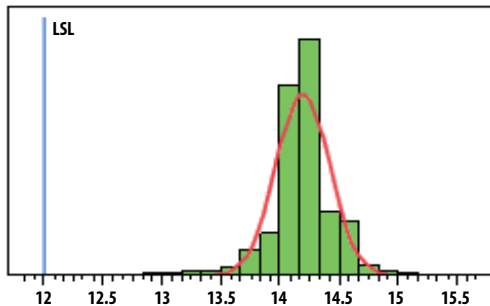

Figure 1. Gain at 1.575 GHz; LSL = 12 dB, nominal = 14.2 dB

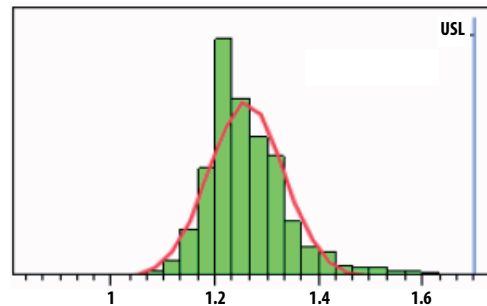

Figure 2. NF at 1.575GHz; USL = 1.7 dB, nominal = 1.26 dB

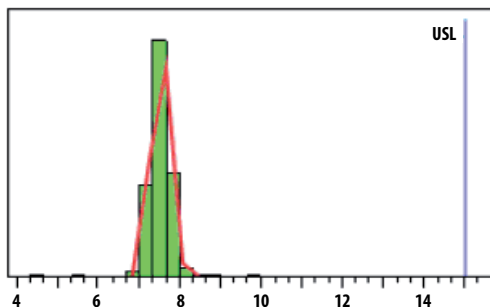

Figure 3. I<sub>d</sub> at 1.575 GHz; USL = 15 mA, nominal = 7.5 mA

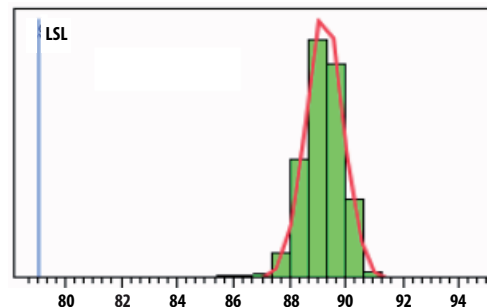

Figure 4. Cell band Rejection at 928MHz relative to 1.575 GHz; LSL = 79 dBc, nominal = 89.2 dBc

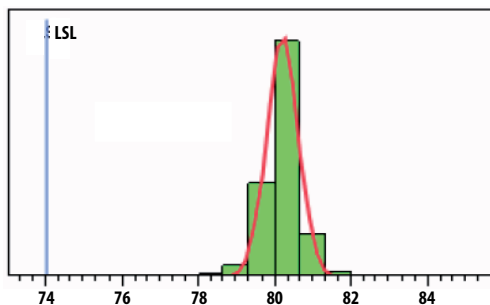

Figure 5. PCS band Rejection at 1850MHz relative to 1.575 GHz; LSL = 74 dBc, nominal = 80.2 dBc

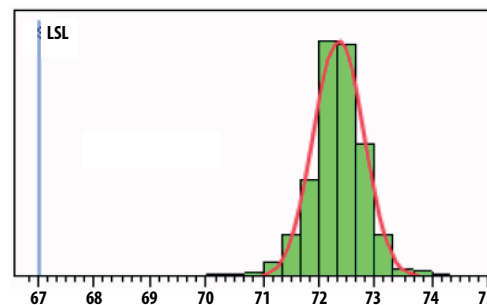

Figure 6. WLAN band Rejection at 2500MHz relative to 1.575 GHz; LSL = 67 dBc, nominal = 72.3 dBc

Notes:

5. Distribution data sample size is 5000 samples taken from 4 filter wafers and 1 LNA wafer. Future wafers allocated to this product may have nominal values anywhere between the upper and lower limits.
6. Measurements are made on a production test board, which represents a trade-off between optimal Gain, NF, IIP3, IP1dB, VSWR, Cell Band, DCS Band, PCS Band and WLAN Band Rejection. Circuit trace losses (except for NF) have not been de-embedded from actual measurements.

## Electrical Specifications

T<sub>A</sub> = 25°C, Freq = 1.575GHz, measured on demo board<sup>[1]</sup> unless otherwise specified – Typical Performance<sup>[1]</sup>

**Table 1. Performance at V<sub>dd</sub> = V<sub>sd</sub> = 2.7V, I<sub>dd</sub> = 7.5mA (R<sub>bias</sub> = 6.8k Ohm) nominal operating conditions**

Symbol	Parameter and Test Condition	Units	Min.	Typ	Max.
G	Gain	dB	12	14.2	16.3
NF <sup>[2]</sup>	Noise Figure	dB	–	1.26	1.7
IP1dB	Input 1dB Compressed Power	dBm	–	+2	–
IIP3 <sup>[3]</sup>	Input 3 <sup>rd</sup> Order Intercept Point (2-tone @ Fc +/- 2.5MHz)	dBm	0	+5	–
S11	Input Return Loss	dB	–	-9	–
S22	Output Return Loss	dB	–	-12	–
S12	Reverse Isolation	dB	–	-22	–
Low Band Rejection	Worst-case relative to 1.575GHz within (827-928)MHz band, tested at 928MHz	dBc	79	89	–
High Band Rejection	Worst-case relative to 1.575GHz within (1710-1980)MHz band, tested at 1850MHz	dBc	74	80	–
WLAN Band Rejection	Worst-case relative to 1.575GHz within (2400-2500)MHz band, tested at 2500MHz	dBc	67	72	–
IP1dB <sub>890MHz</sub>	Input 1dB gain compression interferer signal level at 890MHz	dBm	–	21	–
IP1dB <sub>1710MHz</sub>	Input 1dB gain compression interferer signal level at 1710MHz	dBm	–	32	–
IP1dB <sub>1885MHz</sub>	Input 1dB gain compression interferer signal level at 1885MHz	dBm	–	37	–
IP1dB <sub>2500MHz</sub>	Input 1dB gain compression interferer signal level at 2500MHz	dBm	–	35	–
OOB IIP3 <sup>[4]</sup>	Out of Band Input 3 <sup>rd</sup> Order Intercept Point (2-tone @ 1712.7 MHz and 1850MHz)	dBm	–	62	–
I <sub>dd</sub>	Supply DC current at Shutdown (SD) voltage V <sub>sd</sub> = 2.7V	mA	4	7.5	15
I <sub>sh</sub>	Shutdown Current @ V <sub>SD</sub> = 0V	uA	–	0.5	110

**Table 2. Performance at Vdd = Vsd = 1.8V, Idd = 5mA (Rbias = 2.7k Ohm) nominal operating conditions**

Symbol	Parameter and Test Condition	Units	Typ
G	Gain	dB	12.8
NF <sup>[2]</sup>	Noise Figure	dB	1.35
IP1dB	Input 1dB Compressed Power	dBm	0
IIP3 <sup>[3]</sup>	Input 3 <sup>rd</sup> Order Intercept Point (2-tone @ Fc +/- 2.5MHz)	dBm	3.5
S11	Input Return Loss	dB	-8
S22	Output Return Loss	dB	-11.5
S12	Reverse Isolation	dB	-21
Low Band Rejection	Worst-case relative to 1.575GHz within (827-928)MHz band, tested at 928MHz	dBc	89
High Band Rejection	Worst-case relative to 1.575GHz within (1710-1980)MHz band, tested at 1850MHz	dBc	79
WLAN Band Rejection	Worst-case relative to 1.575GHz within (2400-2500)MHz band, tested at 2500MHz	dBc	71
IP1dB890MHz	Input 1dB gain compression interferer signal level at 890MHz	dBm	20
IP1dB1710MHz	Input 1dB gain compression interferer signal level at 1710MHz	dBm	32
IP1dB1885MHz	Input 1dB gain compression interferer signal level at 1885MHz	dBm	37
IP1dB2500MHz	Input 1dB gain compression interferer signal level at 2500MHz	dBm	35
Idd	Supply DC current at Shutdown (SD) voltage Vsd = 1.8V	mA	5

## Notes:

1. Measurements at 1.575GHz obtained using demo board
2. Losses from demoboard deembedded
3. 1.575GHz IIP3 test condition:  $F_{RF1} = 1572.5$  MHz,  $F_{RF2} = 1577.5$  MHz with input power of -20dBm per tone measured at the worst case side band
4. 1.575GHz IIP3 test condition:  $F_{RF1} = 1712.7$  MHz,  $F_{RF2} = 1850$  MHz with input power of 10dBm per tone measured at the worst case side band

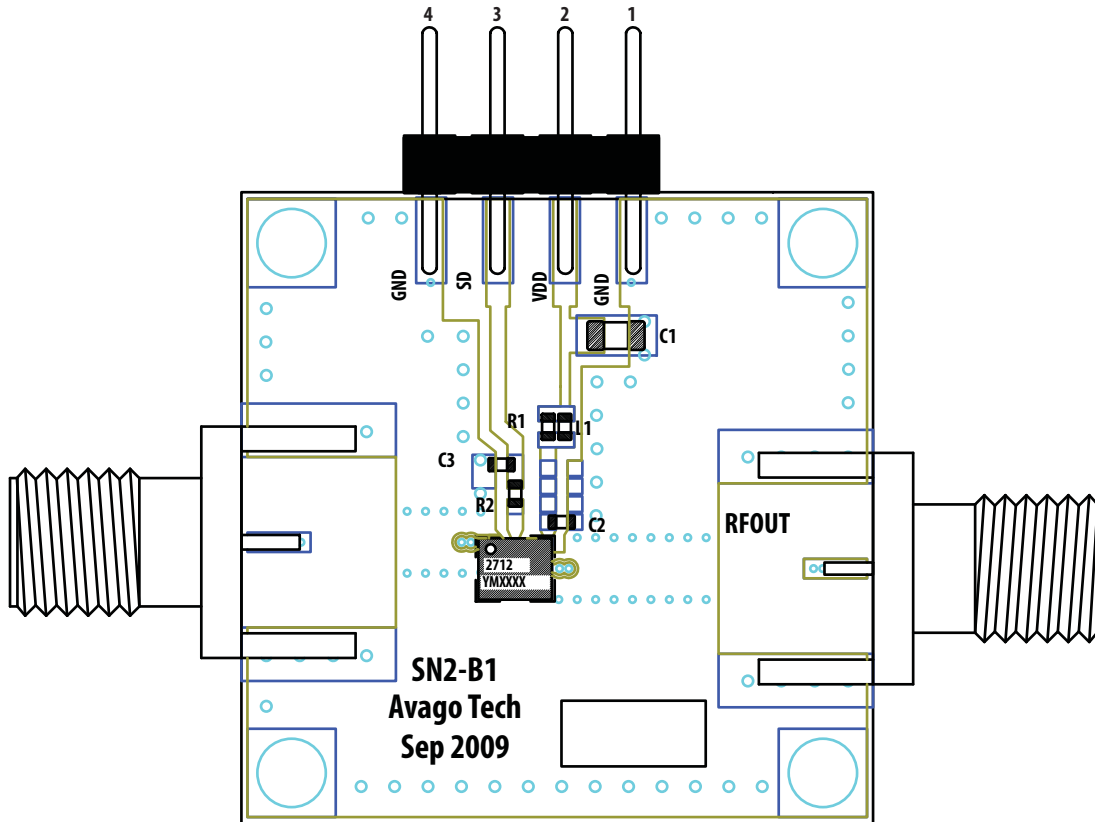

**DC Pin Configuration of 4-Pins connector**

Pins pointing out of the page

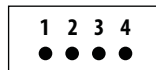

Pins 1, 4 = GND  
 Pin 2 = Vdd Supply  
 Pin 3 = Shutdown (SD)

Circuit Symbol	Size	Description
L1	0402	22 nH Inductor (Taiyo Yuden HK100522NJ-T)
C1	0805	0.1 uF Capacitor (Murata GRM21BR71H104KA01L)
C2	0402	47 pF Capacitor (Kyocera CM05CH470J50AHF)
C3	0402	6.8 pF Capacitor (Kyocera CM05CG6R8C50AHF)
R1	0402	12 Ohms Resistor (RK73B1ETTP120J)
R2	0402	6.8 kOhm Resistor (RK73B1ETTP6R8J)

Figure 7. Demoboard and application circuit components table

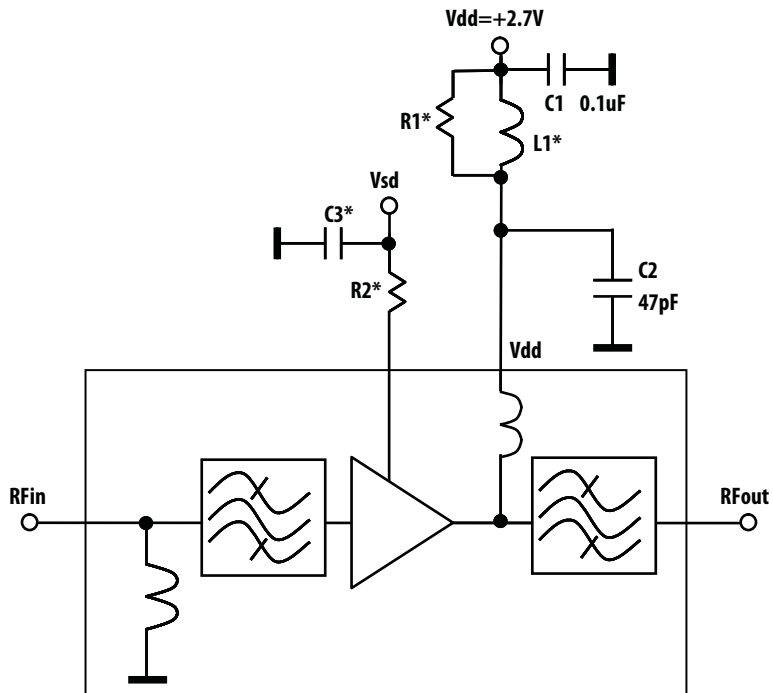

**Figure 8. Application Circuit**

\* optional, see notes below

Notes

- The module is fully matched at the input and output RF pins. The RFin input pin is connected directly to a shunt inductor to ground. As such a DC blocking capacitor is required if DC voltages are present. The RFoutput pin is already DC-blocked by the internal filter inside the module.
- Best noise performance is obtained using high-Q wirewound inductors. This circuit demonstrates that low noise figures are obtainable with standard 0402 chip inductors.
- C1 and C2 are bypass capacitors for RF and low frequency stability and linearity .
- L1 and R1 isolates the demoboard from external disturbances during measurement. It is not needed in actual application. Likewise, C3 mitigate the effect of external noise pickup on the Vsd line. This component are not required in actual operation. Minimal component operation is as shown in the schematic on page 1.
- Bias control is achieved by either varying the Vsd voltage with/ without R2, or fixing the Vsd voltage to Vdd and adjusting R2 for the desired current.

## ALM-2712 Typical Performance Curves at 25°

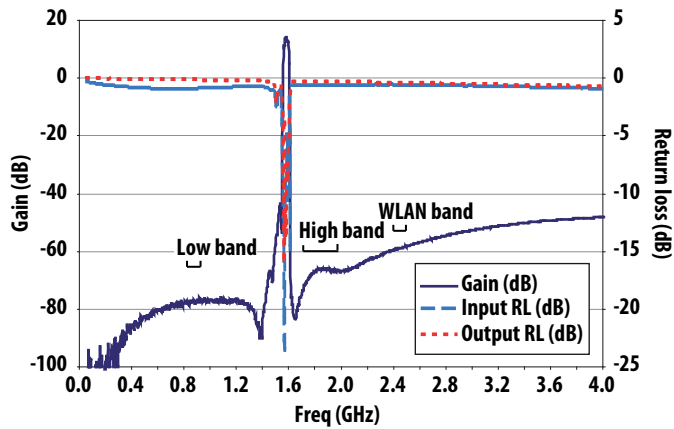

Figure 9a. Typical S-Parameter Plot @ Vdd = 2.7V, Idd = 7.5mA

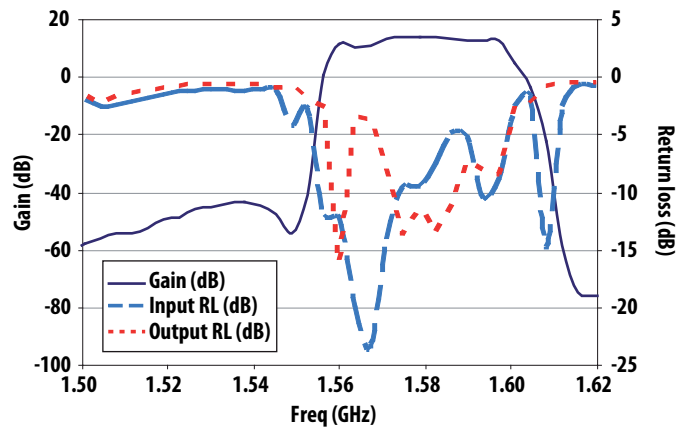

Figure 9b. Passband response of typical S-Parameter Plot @ Vdd = 2.7V, Idd = 7.5mA

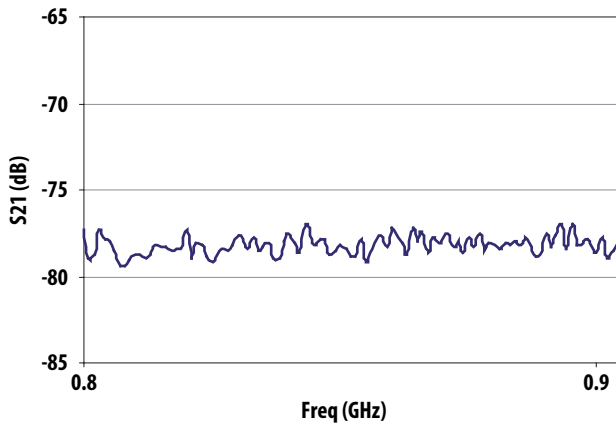

Figure 9c. Rejection plot for Low band @ Vdd = 2.7V, Idd = 7.5mA

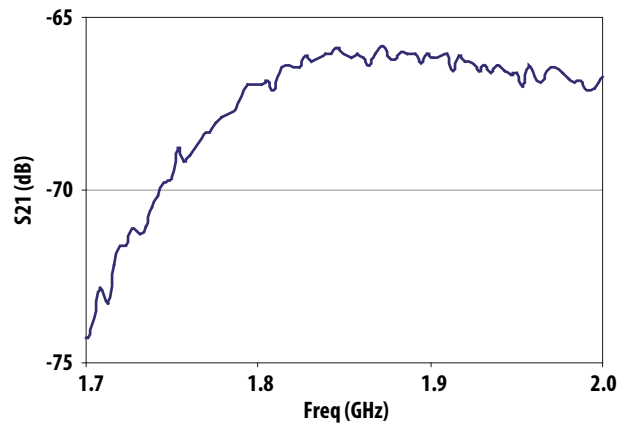

Figure 9d. Rejection plot for High band @ Vdd = 2.7V, Idd = 7.5mA

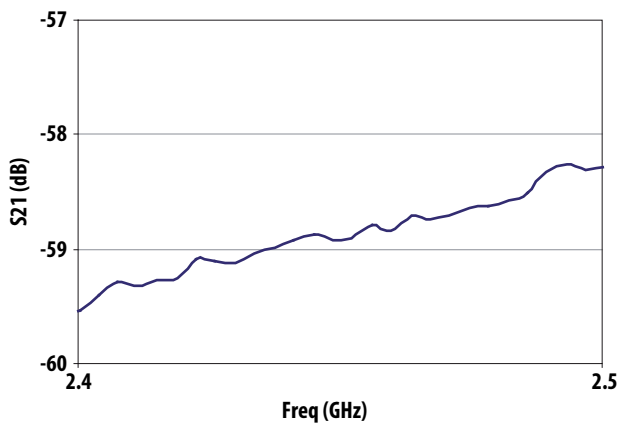

Figure 9e. Rejection plot for WLAN band @ Vdd = 2.7V, Idd = 7.5mA

## ALM-2712 Typical Performance Curves at 25°

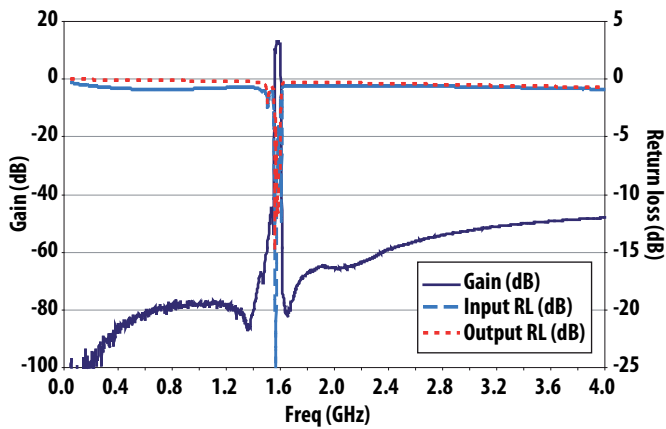

Figure 10a. Typical S-Parameter Plot @  $V_{dd} = 1.8V$ ,  $I_{dd} = 5mA$

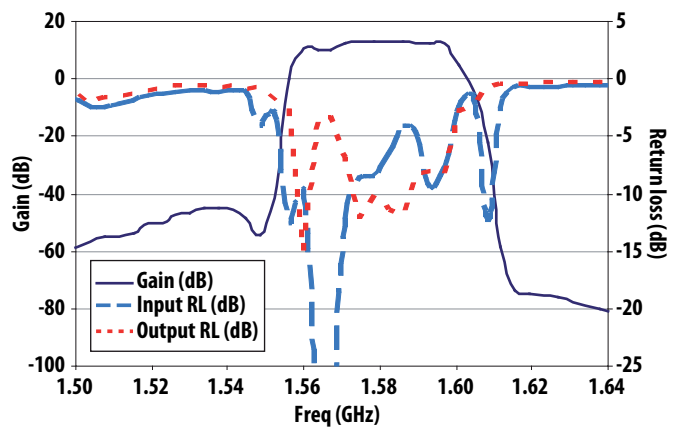

Figure 10b. Passband response of typical S-Parameter Plot @  $V_{dd} = 1.8V$ ,  $I_{dd} = 5mA$

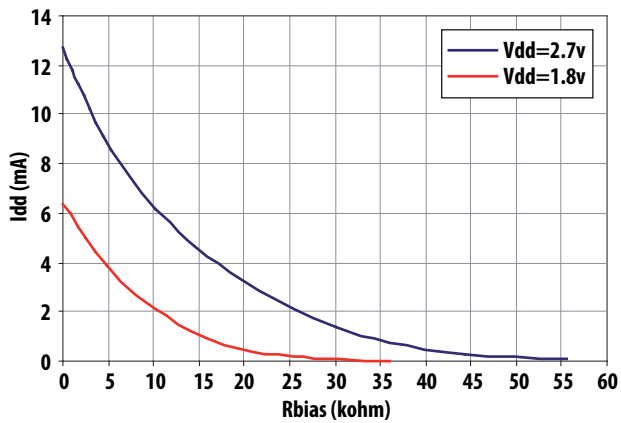

Figure 11.  $I_{dd}$  vs  $R_{bias}$  at 25°C

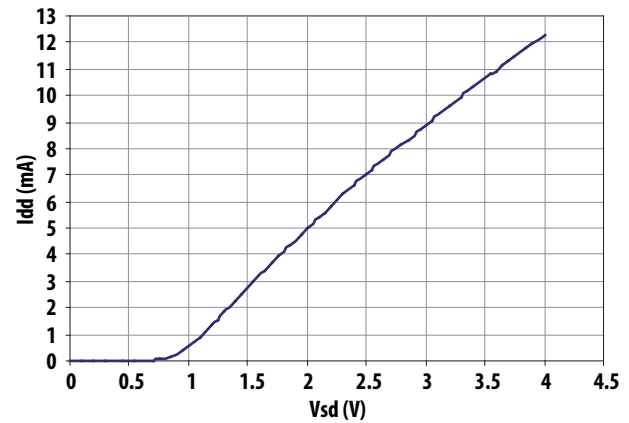

Figure 12.  $I_{dd}$  vs  $V_{sd}$  for  $V_{dd} = 2.7V$ ,  $R_2 = 6.8k \text{ Ohm}$

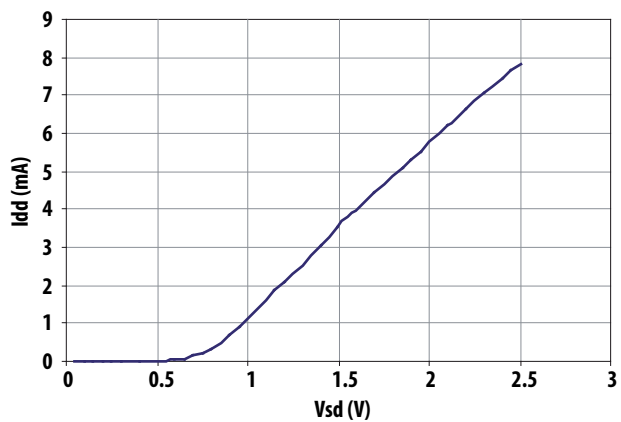

Figure 13.  $I_{dd}$  vs  $V_{sd}$  for  $V_{dd} = 1.8V$ ,  $R_2 = 2.7k \text{ Ohm}$



## ALM-2712 Typical Performance Curves

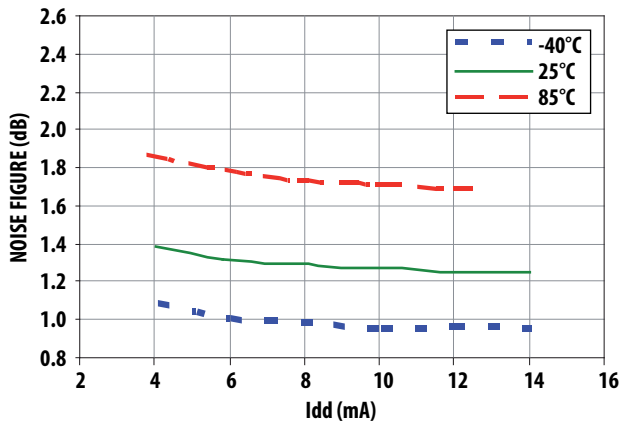

Figure 14. NF vs. Idd at Vdd = 2.7V

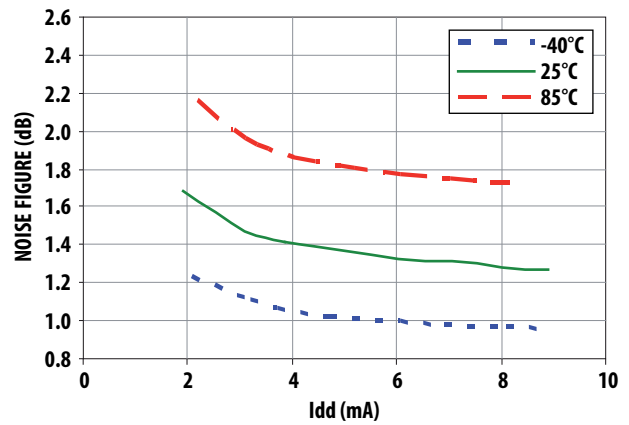

Figure 15. NF vs Idd at Vdd = 1.8V

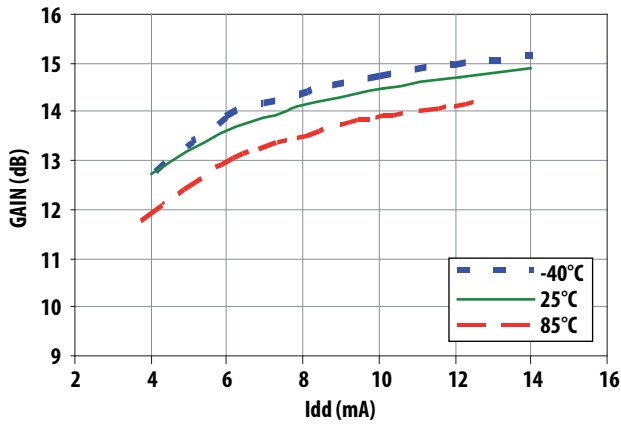

Figure 16. Gain vs. Idd at Vdd = 2.7V

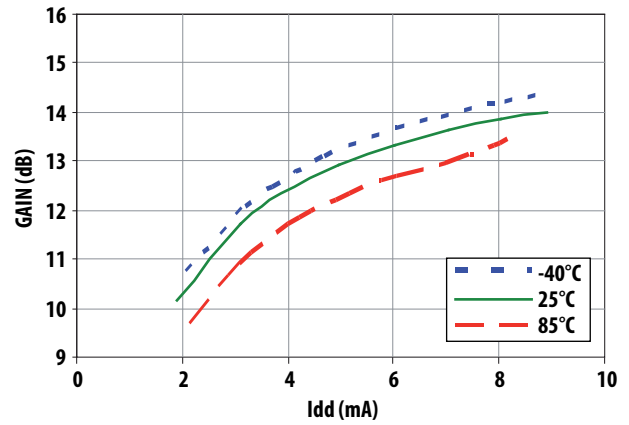

Figure 17. Gain vs. Idd at Vdd = 1.8V

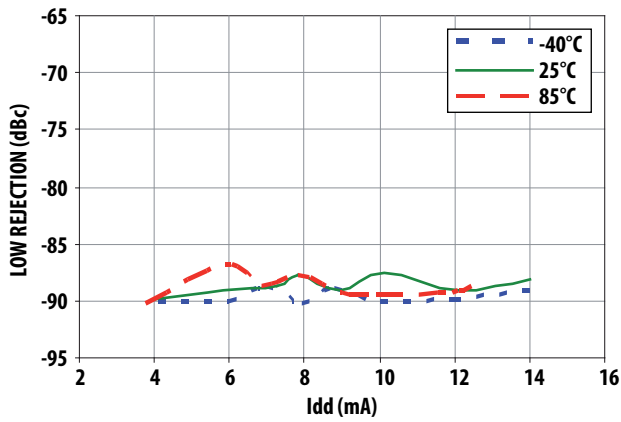

Figure 18. Low band rejection vs. Idd at Vdd = 2.7V

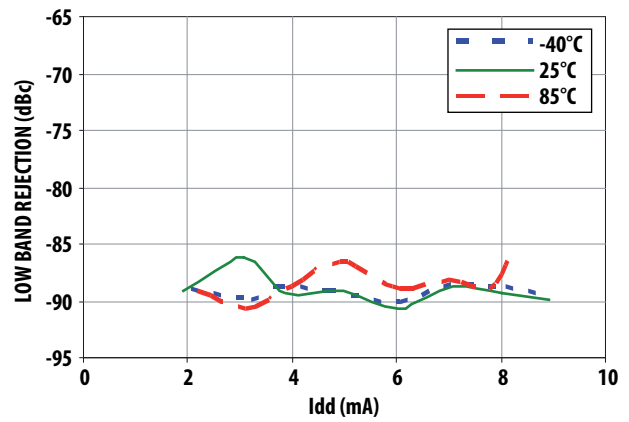

Figure 19. Low band rejection vs. Idd at Vdd = 1.8V

## ALM-2712 Typical Performance Curves

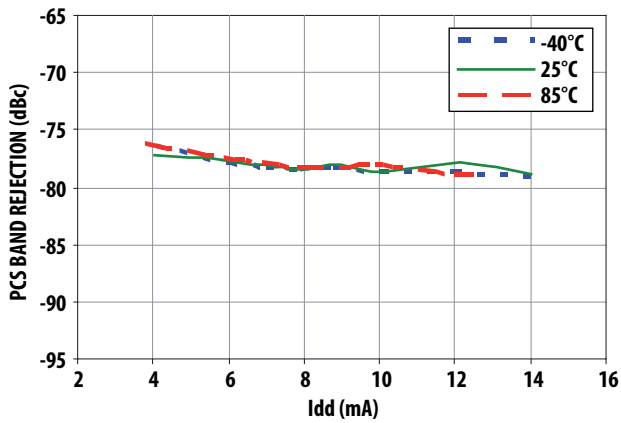

Figure 20. High band rejection vs. Idd at Vdd = 2.7V

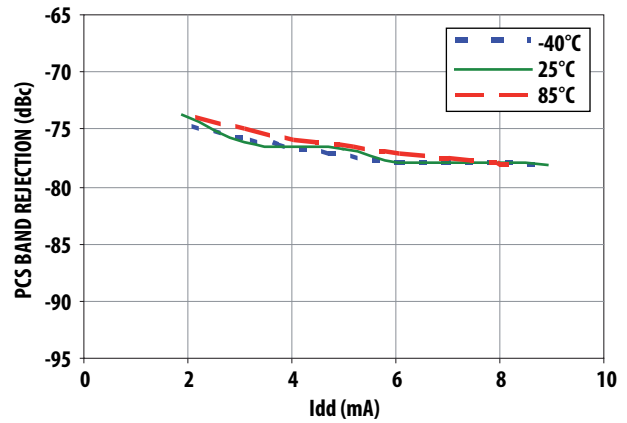

Figure 21. High band rejection vs. Idd at Vdd = 1.8V

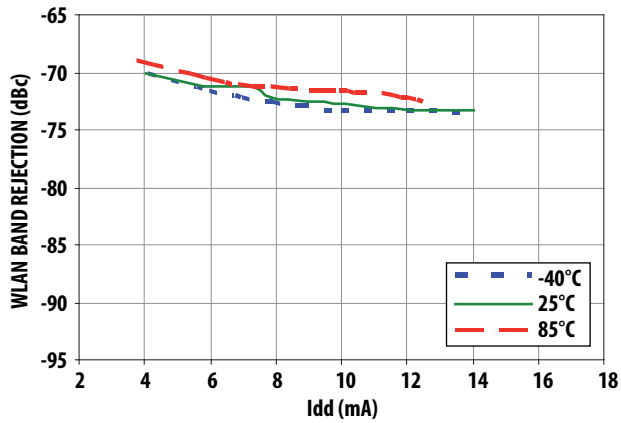

Figure 22. WLAN band rejection vs. Idd at Vdd = 2.7V

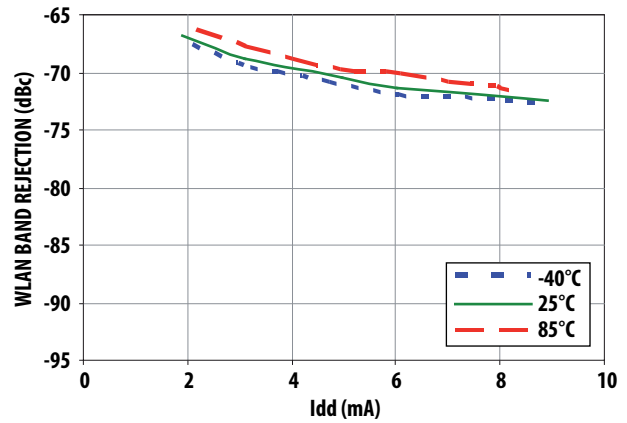

Figure 23. WLAN band rejection vs. Idd at Vdd = 1.8V

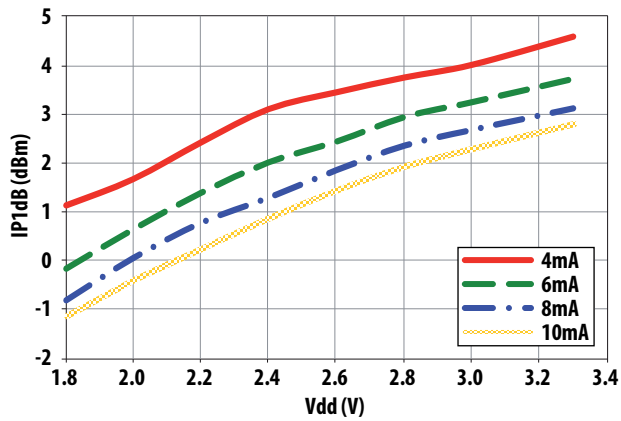

Figure 24. IP1dB vs. Vdd at 25°C

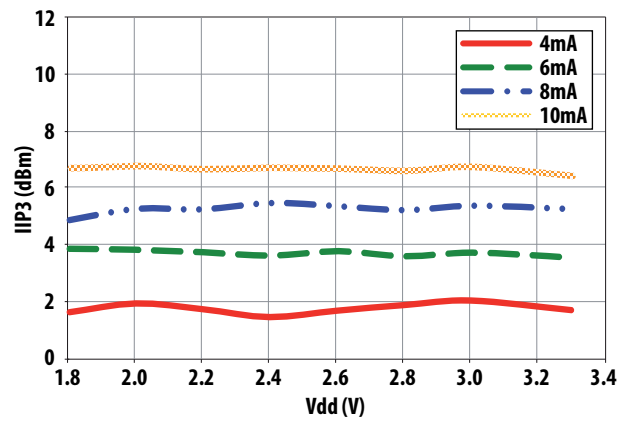

Figure 25. IIP3 vs. Vdd at 25°C

## ALM-2712 Typical Performance Curves at 25°

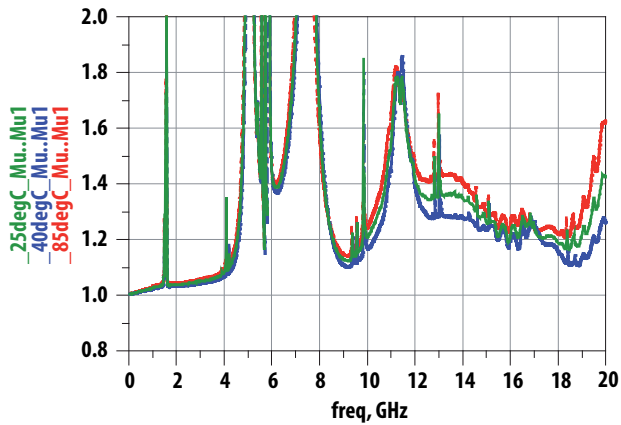

Figure 26. Edwards-Sinsky Output Stability Factor ( $\mu$ ) at  $V_{dd} = 2.7V$

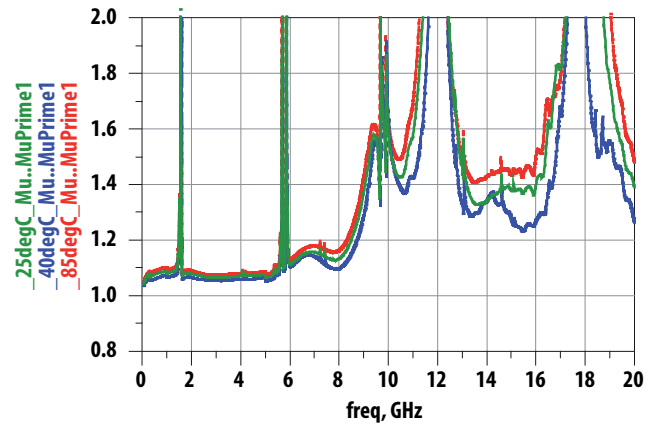

Figure 27. Edwards-Sinsky Input Stability Factor ( $\mu'$ ) at  $V_{dd} = 2.7V$

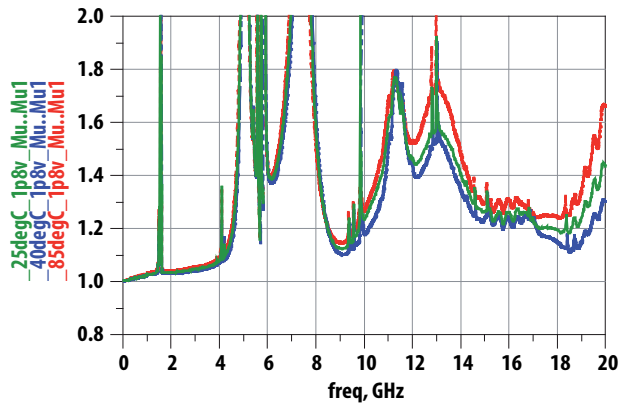

Figure 28. Edwards-Sinsky Output Stability Factor ( $\mu$ ) at  $V_{dd} = 1.8V$

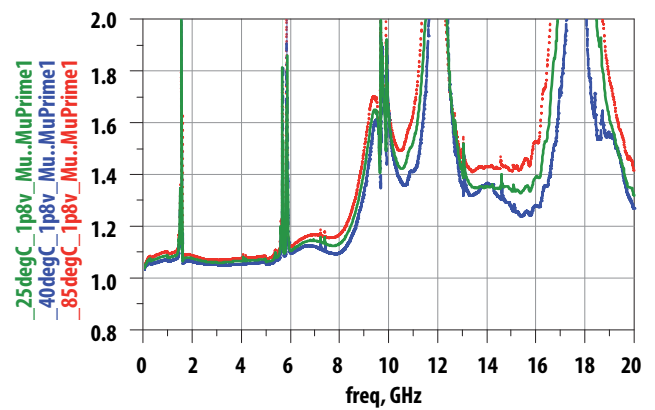

Figure 29. Edwards-Sinsky Input Stability Factor ( $\mu'$ ) at  $V_{dd} = 1.8V$

## ALM-2712 module with differential output

A differential output can be implemented for the ALM-2712 using the schematic shown below. Suggested component values are listed in Table 3. C1, C2 and L1, L2 are to convert the single-ended output to differential outputs while C3, C4 and L3 provide matching to 100 ohm differential impedance.

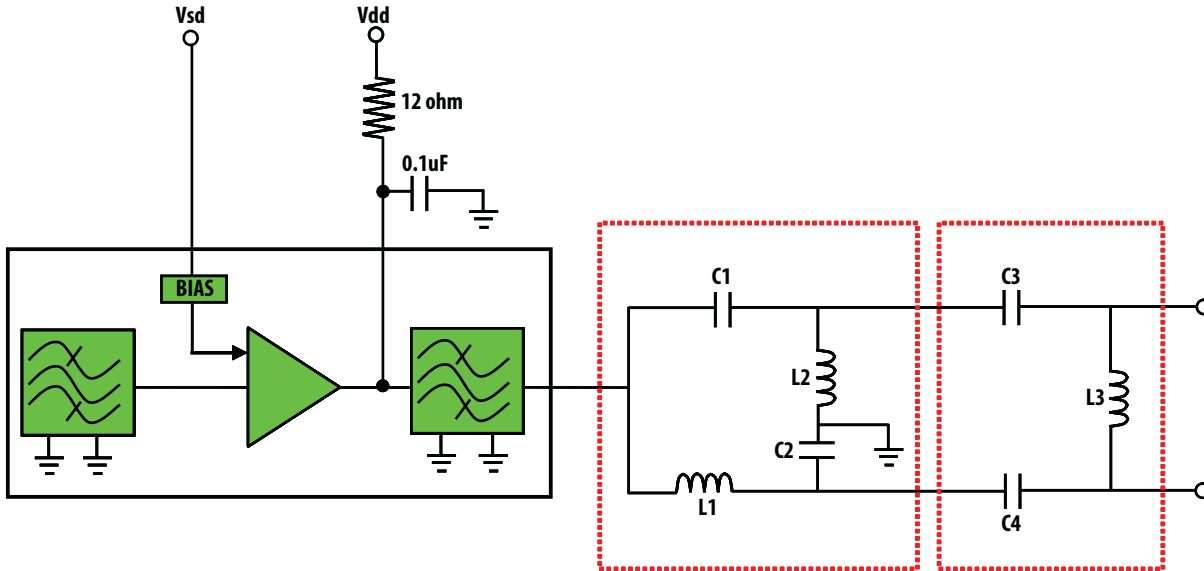

Figure 30. Proposed Balun design for ALM-2712

Table 3. Components table for proposed balun design

Circuit Symbol	Size	Description
C1	0402	GRM1555C1H1R5CZ01 - 1.5pF (Murata)
C2	0402	GRM1555C1H1R5CZ01 - 1.5pF (Murata)
C3	0402	GRM1555C1H101JZ01 - 100pF (Murata)
C4	0402	GRM1555C1H101JZ01 - 100pF (Murata)
L1	0402	LQG15HN6N2S02B - 6.2nH (Murata)
L2	0402	LQG15HN6N2S02B - 6.2nH (Murata)
L3	0402	LQG15HN56NJ02 - 56nH (Murata)

### ALM-2712 Scattering Parameter and Measurement Reference Planes

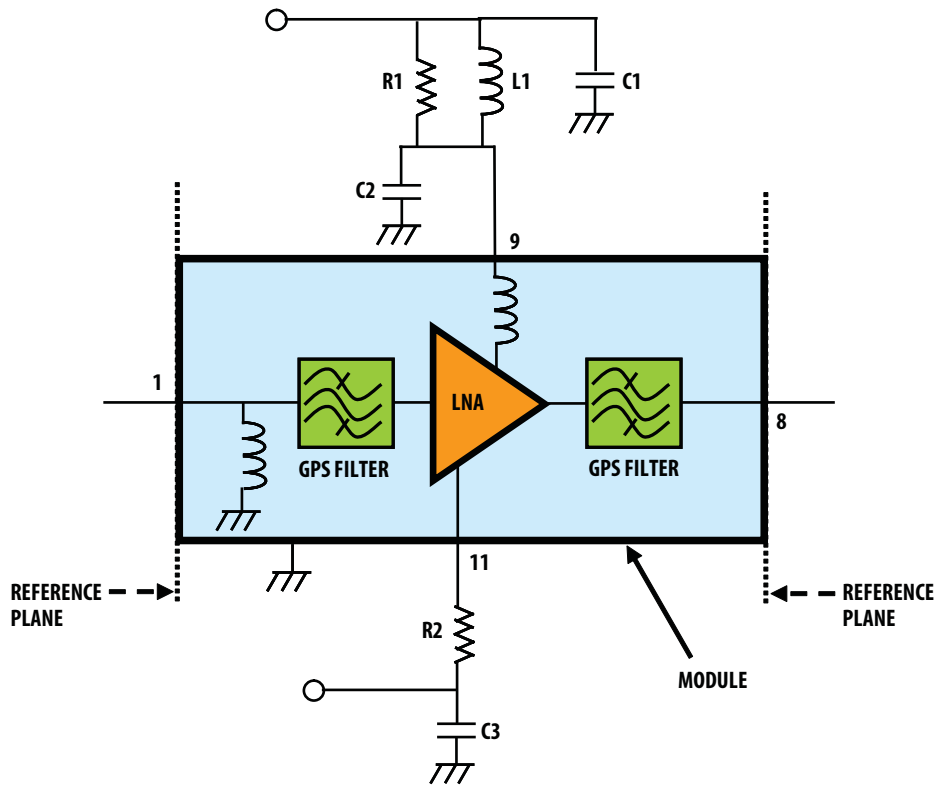

Figure 31. Scattering parameter measurement reference planes

## ALM-2712 Typical Scattering Parameters at 25°C, Vdd = 2.7V, Idd = 7.5mA

The S- and Noise Parameters are measured using a coplanar waveguide PCB with 10 mils Rogers® RO4350. Figure 31 shows the input and output reference planes. The circuit values are as indicated in Figure 7.

Freq (GHz)	S11	S11	S21	S21	S12	S12	S22	S22
	Mag.(dB)	Ang.	Mag.(dB)	Ang.	Mag.(dB)	Ang.	Mag.(dB)	Ang.
0.05	-0.31	170.80	-83.03	-104.09	-82.07	44.11	-0.04	-2.10
0.1	-0.45	162.63	-91.19	-133.63	-87.29	-117.58	-0.04	-4.04
0.2	-0.61	146.95	-85.49	-158.63	-105.71	-138.14	-0.05	-8.05
0.3	-0.69	131.52	-86.12	-170.11	-84.75	173.60	-0.07	-12.05
0.4	-0.63	116.78	-80.42	172.45	-81.30	149.19	-0.09	-16.75
0.5	-0.65	101.23	-76.99	164.58	-79.54	129.05	-0.11	-20.80
0.6	-0.67	85.53	-74.18	152.43	-77.96	123.93	-0.12	-24.96
0.7	-0.70	69.54	-71.57	142.72	-77.13	115.74	-0.14	-28.91
0.8	-0.70	53.51	-69.94	134.56	-77.23	108.18	-0.15	-33.17
0.8275	-0.71	48.94	-69.50	132.51	-78.12	101.20	-0.16	-34.23
0.9	-0.73	37.09	-68.30	124.17	-79.59	98.55	-0.15	-37.27
1.0	-0.71	20.53	-67.39	115.43	-84.87	94.32	-0.18	-41.80
1.1	-0.64	3.58	-66.86	105.52	-86.38	-135.83	-0.26	-46.16
1.2	-0.64	-13.44	-67.13	94.85	-75.73	-136.45	-0.28	-51.10
1.3	-0.66	-31.46	-69.21	85.99	-69.32	-143.51	-0.29	-56.59
1.4	-0.72	-52.97	-70.77	155.40	-64.17	-155.77	-0.31	-63.87
1.5	-3.28	-87.10	-50.68	128.48	-60.23	163.10	-1.27	-81.99
1.575	-6.86	155.59	14.22	158.05	-24.45	109.55	-16.06	48.60
1.6	-1.40	75.37	2.56	-23.68	-35.92	-70.72	-2.87	7.77
1.7	-0.54	-42.34	-72.93	-43.73	-66.72	-157.70	-0.34	-56.92
1.8	-0.55	-64.37	-67.05	-140.19	-62.07	-159.89	-0.33	-65.96
1.885	-0.55	-76.05	-65.86	171.74	-59.97	-167.07	-0.33	-71.06
1.9	-0.54	-77.85	-66.28	167.55	-59.76	-167.56	-0.32	-71.84
2.0	-0.52	-88.32	-68.97	165.02	-57.77	-174.89	-0.30	-76.82
2.1	-0.48	-97.15	-67.77	-167.31	-56.38	179.56	-0.29	-81.40
2.2	-0.47	-104.75	-63.73	-159.31	-55.14	173.45	-0.29	-85.72
2.3	-0.45	-111.48	-60.55	-161.04	-53.94	168.47	-0.30	-89.76
2.4	-0.42	-117.48	-58.09	-167.11	-53.02	164.21	-0.28	-93.56
2.5	-0.42	-122.83	-56.14	-173.64	-52.16	159.82	-0.29	-97.37
3.0	-0.39	-143.61	-49.78	157.21	-48.64	141.38	-0.31	-113.86
3.5	-0.38	-159.85	-46.25	130.99	-45.99	125.86	-0.38	-129.21
4.0	-0.41	-175.25	-43.82	103.12	-43.47	110.17	-0.57	-147.20
4.5	-0.43	169.03	-42.02	66.73	-40.64	87.29	-1.49	179.88
5.0	-0.45	152.81	-43.25	13.11	-40.32	28.92	-13.91	-1.00
6.0	-0.74	133.10	-34.84	-41.55	-45.21	-18.94	-2.78	-127.80
7.0	-1.03	84.73	-23.30	-162.23	-33.21	-171.36	-5.31	166.63
8.0	-1.26	47.03	-17.99	69.49	-24.52	63.46	-3.22	-171.73
9.0	-4.34	-6.32	-23.93	-24.57	-27.17	-37.05	-0.92	131.53
10.0	-4.99	-41.52	-32.95	28.66	-39.02	-143.79	-1.74	86.44
11.0	-5.07	-81.98	-17.92	-12.54	-31.83	38.92	-4.49	21.14
12.0	-9.49	-60.36	-16.24	-131.21	-26.66	-90.81	-3.09	3.65
13.0	-2.31	-96.01	-16.02	172.58	-24.60	-156.01	-2.18	-31.75
14.0	-1.86	-143.41	-13.71	113.85	-20.54	140.40	-2.65	-52.46
15.0	-2.24	-164.69	-10.91	48.60	-16.10	71.01	-3.81	-53.45
16.0	-1.53	-179.61	-13.27	-10.99	-17.57	4.74	-2.11	-65.14
17.0	-3.24	149.33	-12.37	-32.48	-18.09	-15.22	-2.37	-95.58
18.0	-13.98	-109.52	-12.08	-53.35	-15.98	-30.05	-1.01	-123.66
19.0	-7.00	168.64	-6.40	-112.24	-9.24	-87.81	-1.72	-141.00
20.0	-10.28	172.65	-2.59	173.75	-4.38	-165.83	-20.74	95.73

**ALM-2712 Typical Scattering Parameters at 25°C, Vdd = 1.8V, Idd = 5mA**

Freq (GHz)	S11	S11	S21	S21	S12	S12	S22	S22
	Mag.(dB)	Ang.	Mag.(dB)	Ang.	Mag.(dB)	Ang.	Mag.(dB)	Ang.
0.05	-0.31	170.81	-77.61	-81.92	-80.55	-58.15	-0.04	-2.10
0.1	-0.45	162.64	-94.26	-167.43	-87.82	118.85	-0.04	-4.03
0.2	-0.61	146.96	-96.81	135.59	-94.38	-173.28	-0.05	-8.04
0.3	-0.69	131.53	-88.74	147.68	-84.55	166.83	-0.07	-12.05
0.4	-0.63	116.79	-84.40	166.61	-82.69	144.01	-0.09	-16.76
0.5	-0.65	101.24	-79.10	165.96	-80.74	125.53	-0.11	-20.81
0.6	-0.67	85.55	-74.78	146.65	-78.31	117.68	-0.12	-24.96
0.7	-0.69	69.56	-73.51	140.49	-78.18	118.80	-0.13	-28.92
0.8	-0.70	53.54	-71.44	134.00	-77.80	105.74	-0.15	-33.17
0.8275	-0.71	48.96	-71.30	131.37	-77.54	104.95	-0.15	-34.24
0.9	-0.72	37.11	-70.19	126.32	-78.57	93.95	-0.14	-37.27
1.0	-0.70	20.56	-69.21	120.45	-83.41	100.05	-0.18	-41.81
1.1	-0.64	3.61	-68.64	113.54	-86.60	-148.54	-0.26	-46.17
1.2	-0.64	-13.41	-68.93	104.86	-75.47	-136.57	-0.28	-51.12
1.3	-0.66	-31.42	-71.27	98.24	-69.48	-143.75	-0.29	-56.61
1.4	-0.71	-52.93	-69.91	167.28	-64.36	-154.58	-0.31	-63.89
1.5	-3.27	-87.09	-52.30	133.00	-60.25	168.15	-1.27	-82.00
1.575	-6.62	169.84	12.90	162.11	-21.82	100.95	-13.61	57.50
1.6	-1.21	76.66	1.31	-22.01	-33.19	-81.74	-2.99	7.65
1.7	-0.53	-42.32	-76.33	-67.22	-68.06	-133.30	-0.33	-56.94
1.8	-0.55	-64.34	-65.49	-150.00	-61.97	-160.04	-0.33	-65.97
1.885	-0.54	-76.02	-63.54	175.01	-59.86	-167.29	-0.33	-71.08
1.9	-0.53	-77.80	-63.44	171.11	-59.56	-167.56	-0.31	-71.85
2.0	-0.51	-88.30	-65.49	160.86	-57.74	-174.81	-0.30	-76.83
2.1	-0.48	-97.12	-65.69	-179.62	-56.42	178.84	-0.29	-81.41
2.2	-0.46	-104.71	-62.61	-167.76	-55.07	174.31	-0.29	-85.72
2.3	-0.44	-111.44	-59.59	-167.37	-54.02	169.37	-0.30	-89.76
2.4	-0.42	-117.46	-57.12	-171.77	-53.01	164.16	-0.28	-93.55
2.5	-0.41	-122.79	-55.34	-177.94	-52.13	159.89	-0.29	-97.36
3.0	-0.38	-143.57	-49.45	154.06	-48.61	141.44	-0.30	-113.86
3.5	-0.37	-159.81	-46.14	129.65	-45.96	125.97	-0.37	-129.26
4.0	-0.40	-175.18	-43.72	104.76	-43.49	110.10	-0.56	-147.34
4.5	-0.42	169.08	-41.69	71.59	-40.74	87.15	-1.47	179.69
5.0	-0.45	152.85	-43.01	17.04	-40.77	30.19	-13.70	-6.62
6.0	-0.72	133.14	-36.12	-33.98	-45.30	-12.03	-2.83	-129.05
7.0	-1.01	84.76	-24.40	-161.09	-33.57	-172.42	-5.84	168.64
8.0	-1.25	46.81	-18.71	73.57	-24.83	66.78	-3.27	-174.08
9.0	-4.36	-5.43	-24.36	-26.76	-26.84	-38.03	-0.89	131.47
10.0	-4.98	-41.21	-33.39	32.50	-40.93	-164.30	-1.84	85.82
11.0	-5.17	-82.21	-18.05	-12.05	-29.46	34.91	-4.45	21.32
12.0	-8.58	-58.62	-16.59	-134.08	-25.33	-93.88	-3.11	4.41
13.0	-2.24	-97.70	-16.73	171.51	-23.94	-154.79	-2.58	-28.58
14.0	-1.86	-144.22	-14.44	112.09	-20.14	142.24	-2.66	-50.63
15.0	-2.23	-166.30	-11.88	50.77	-15.99	77.15	-3.40	-55.52
16.0	-1.70	179.38	-13.55	-9.10	-16.80	11.54	-1.95	-64.65
17.0	-3.87	149.02	-12.86	-37.76	-16.33	-13.32	-1.96	-95.34
18.0	-13.35	-100.14	-13.12	-52.83	-15.15	-31.69	-1.02	-126.61
19.0	-5.76	179.34	-6.66	-106.45	-8.01	-87.53	-2.40	-146.31
20.0	-7.61	164.77	-3.09	174.03	-4.01	-170.19	-19.04	5.34

**ALM-2712 Typical Noise Parameters at 25°C,  
Freq = 1.575 GHz, Vdd = 2.7V, Idd = 7.5mA**

Freq (GHz)	Fmin (dB)	GAMMA OPT		
		Mag	Ang	Rn/50
1.575	1.14	0.084	44.1	0.1714

**ALM-2712 Typical Noise Parameters at 25°C,  
Freq = 1.575 GHz, Vdd = 1.8V, Idd = 5mA**

Freq (GHz)	Fmin (dB)	GAMMA OPT		
		Mag	Ang	Rn/50
1.575	1.21	0.100	78.1	0.1780

Notes:

The exceptional noise figure performance of the ALM-2712 is due to its highly optimized design. In this regard, the Fmin of the ALM-2712 shown above is locked down by the internal input pre-match. This allows the use of relatively inexpensive chip inductors for external matching.

**Part Number Ordering Information**

Part Number	Qty	Container
ALM-2712-BLKG	100	7" Reel
ALM-2712-TR1G	3000	13" Reel
ALM-2712-SG1G	3000	13" Reel

**Package Dimensions**

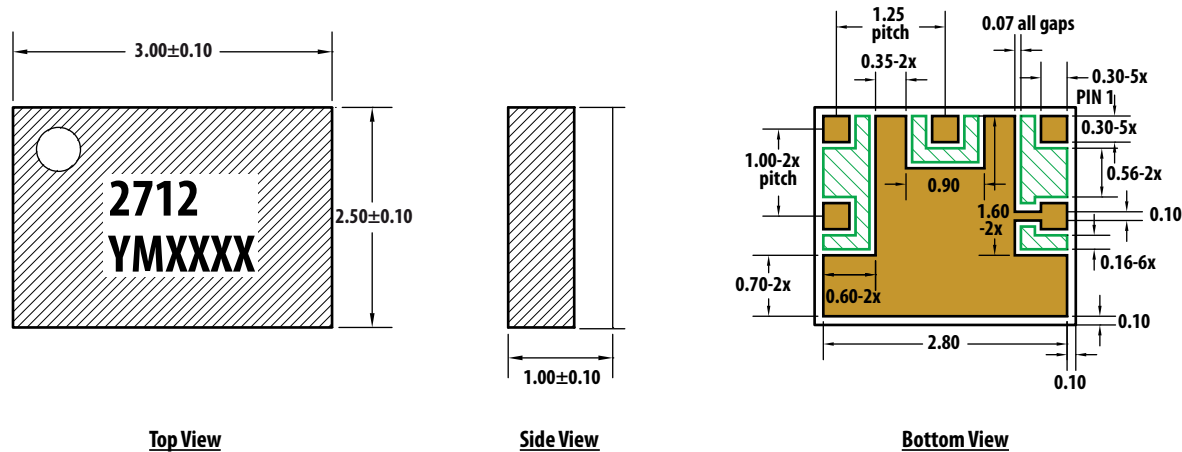

Notes:

1. All dimensions are in millimeters.
2. Dimensions are inclusive of plating.
3. Dimensions are exclusive of mold flash and metal burr.
4. Y refers to year, M refers to month & XXXX refers to last 4 digit of lot number.



## PCB Land Patterns and Stencil Design

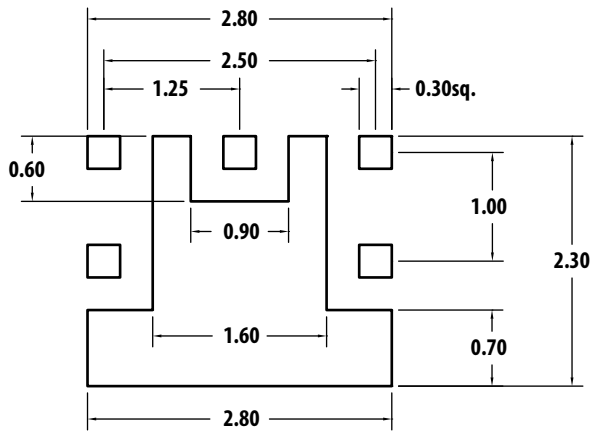

Land Pattern

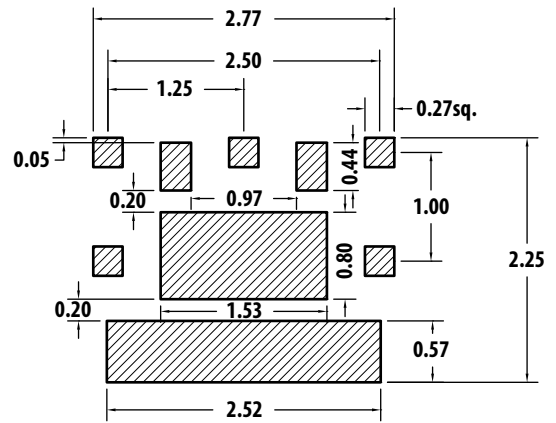

Stencil Opening

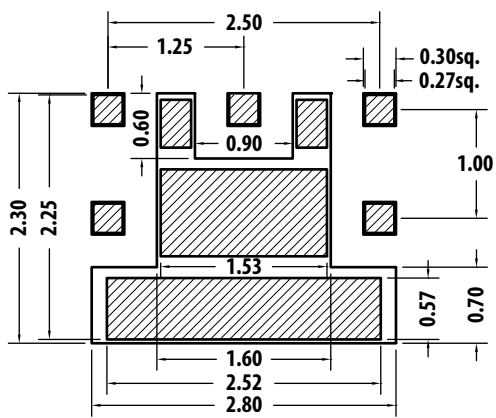

Combination of Land Pattern and Stencil Opening

Notes:

1. All dimensions are in millimeters
2. Recommended stencil thickness is 4mils

## Device Orientation

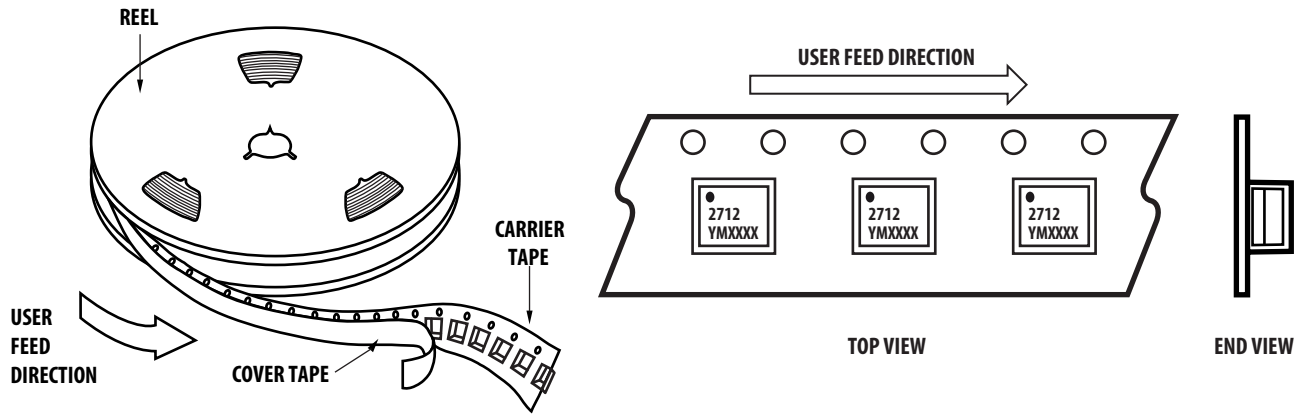

## Tape Dimensions

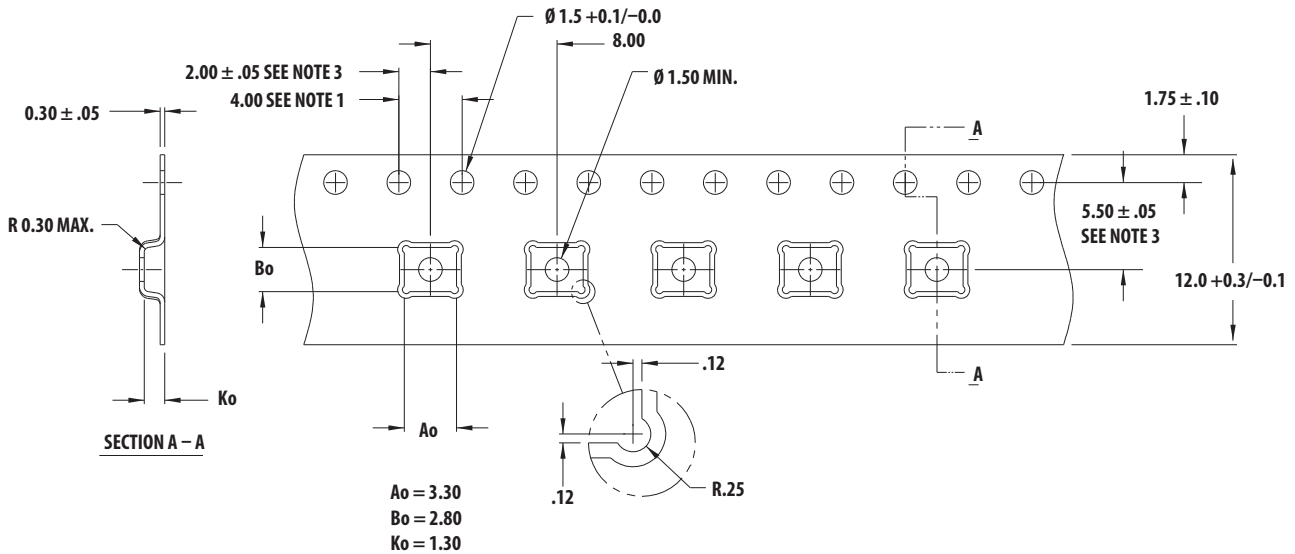

### Notes:

1. All dimensions in mm
2. 10 sprocket hole pitch cumulative tolerance  $\pm 0.2$
3. Camber in compliance with EIA 481
4. Pocket position relative to sprocket hole measured as true position of pocket, not pocket hole
5. Ao and Bo are calculated on a plane at a distance "R" above the bottom of the pocket.

# Reel Dimensions (7" reel)

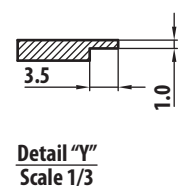
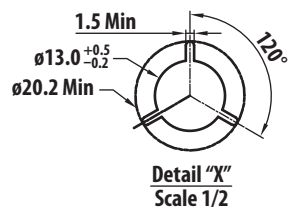
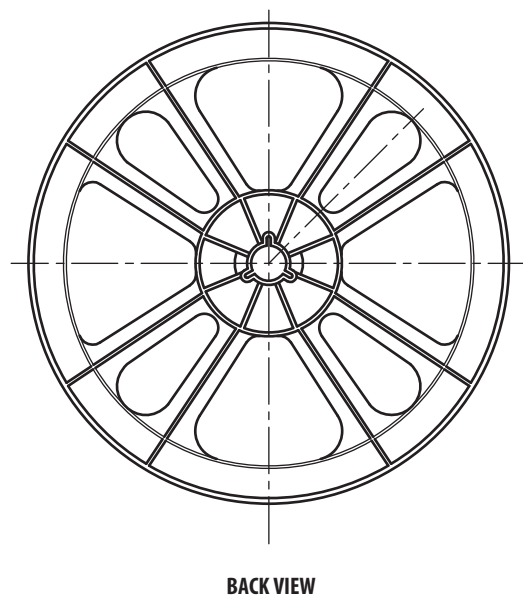
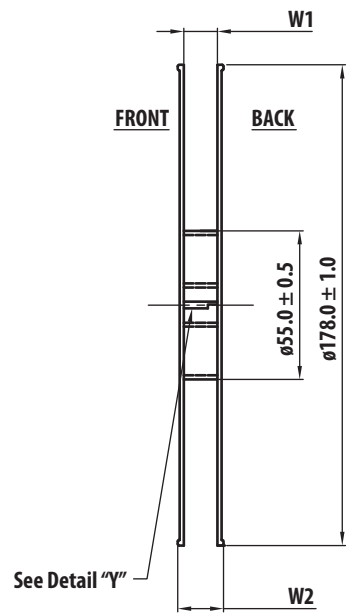
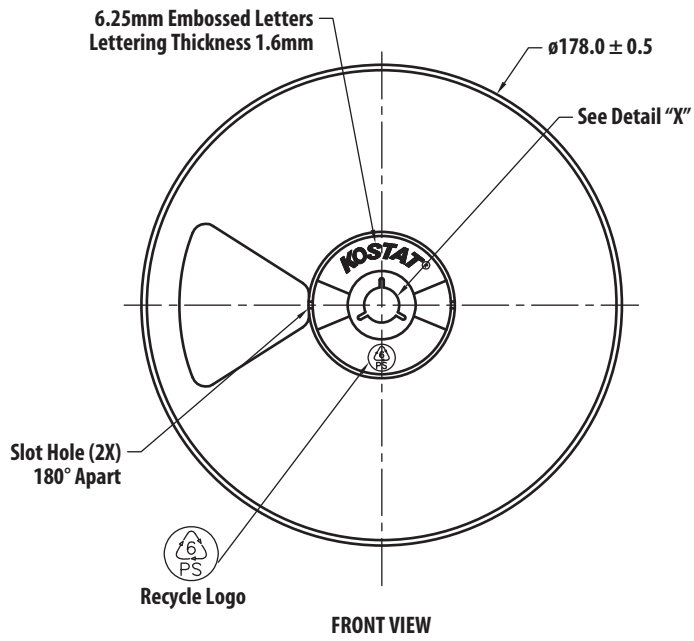

# Reel Dimensions (13" reel)

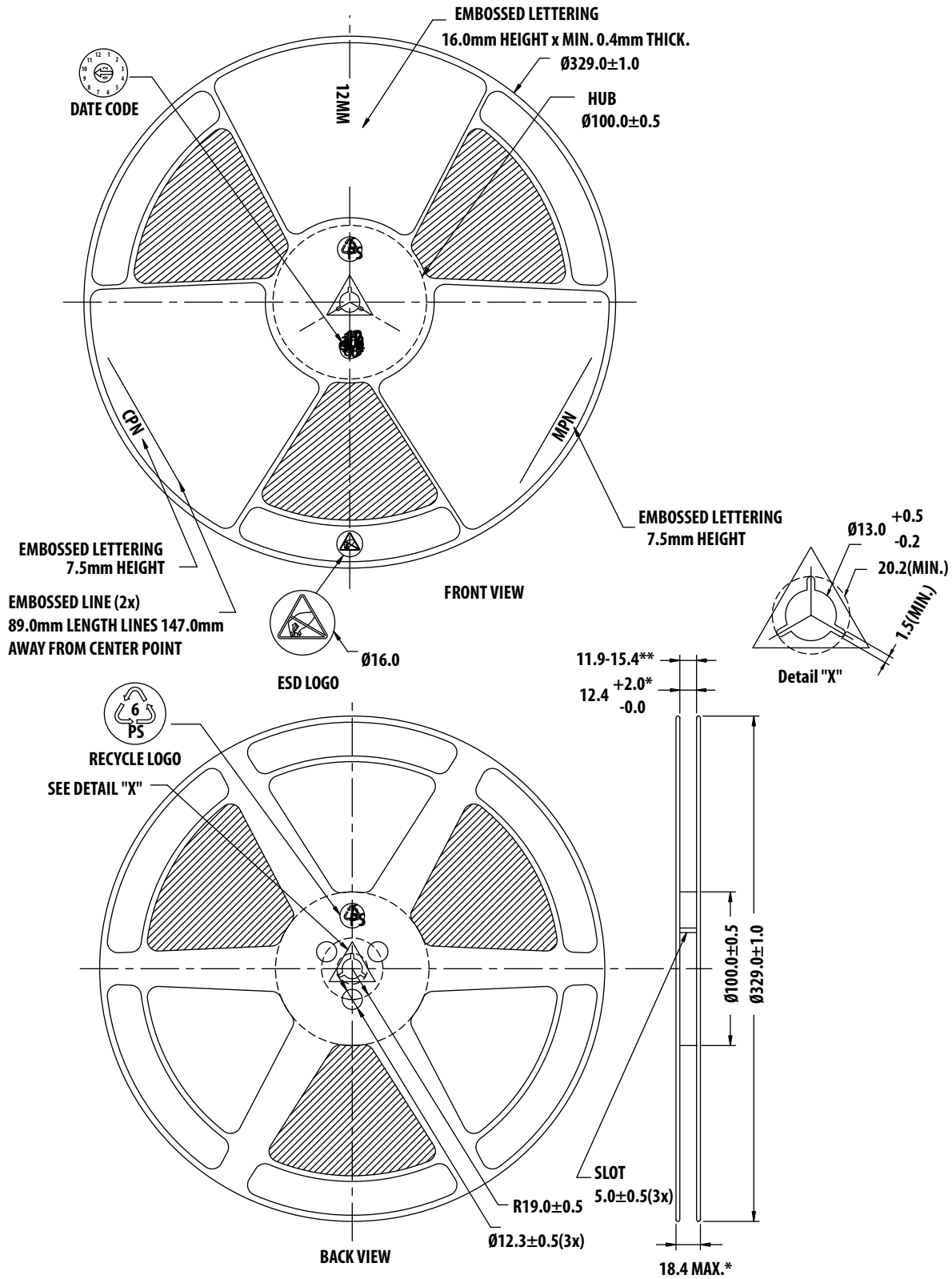

For product information and a complete list of distributors, please go to our web site: [www.avagotech.com](http://www.avagotech.com)

Avago, Avago Technologies, and the A logo are trademarks of Avago Technologies in the United States and other countries. Data subject to change. Copyright © 2005-2010 Avago Technologies. All rights reserved. AV02-2369EN - September 9, 2010

