

ALM-1612

GPS LNA-Filter Front-End Module



Data Sheet

Description

Avago Technologies' ALM-1612 is a GPS front-end module that combines a low-noise amplifier (LNA) with a GPS FBAR filter. The LNA uses Avago Technologies' proprietary GaAs Enhancement-mode pHEMT process to achieve high gain with very low noise figure and high linearity. Noise figure distribution is very tightly controlled. A CMOS-compatible shutdown pin is included either for turning the LNA on/off, or for current adjustment. The integrated filter utilizes an Avago Technologies' leading-edge FBAR filter for exceptional rejection at Cell/PCS-Band frequencies.

The low noise figure and high gain, coupled with low current consumption make it suitable for use in critical low-power GPS applications or during low-battery situations.

Component Image

Surface Mount 3.3x2.1x1 mm³ 12-lead MCOB

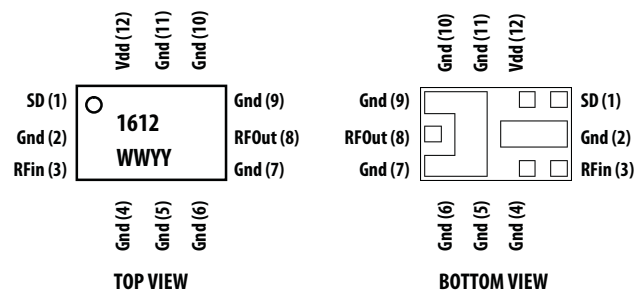

Note:
Package marking provides orientation and identification
"1612" = Product Code
"YY" = Year of manufacture
"WW" = Work week of manufacture

Application Circuit

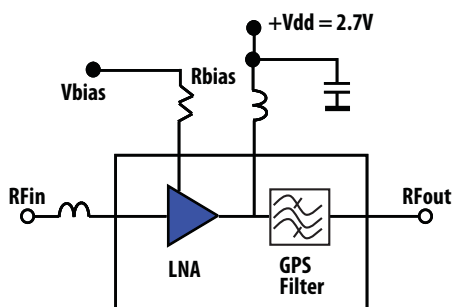

Features

- Very Low Noise Figure: 0.95 dB typ.
- High Gain: 18.2 dB typ.
- High IIP3 and IP1dB
- Exceptional Cell/PCS-Band rejection
- Advanced GaAs E-pHEMT & FBAR Technology
- Low external component count
- Shutdown current: < 5 uA
- CMOS compatible shutdown pin (SD) current @ 2.7 V: 0.1mA
- ESD: For RFin (Pin 3): ESD Human Body Model > 3kV; All other pins: ESD Machine Model = 70V, ESD Human Body Model = 300V
- Meets MSL3
- Useable down to 1.8V supply
- Adjustable current via single external resistor/voltage
- Small package dimension: 3.3(L)x2.1(W)x1(H) mm³

Specifications (Typical performance @ 25°C)

At 1.575GHz, Vdd = 2.7V, Idd = 6.0mA

- Gain = 18.2 dB
- NF = 0.95 dB
- IIP3 = +2 dBm, IP1dB = -8 dBm
- S11 = -9 dB, S22 = -14 dB
- Cell-Band Rejection: 69 dBc
- PCS-Band Rejection: 67 dBc

Application

- GPS Receiver Front-end Module

Absolute Maximum Rating^[1] T_A = 25°C

Symbol	Parameter	Units	Absolute Max.
V _{dd}	Device Drain to Source Voltage ^[2]	V	3.6
I _{dd}	Drain Current ^[2]	mA	15
P _{in,max}	CW RF Input Power (V _{dd} = 2.7V, I _{dd} = 6mA)	dBm	13
P _{diss}	Total Power Dissipation ^[4]	mW	54
T _L	Operating Temperature	°C	-40 to 85
T _j	Junction Temperature	°C	150
T _{STG}	Storage Temperature	°C	-65 to 150

Thermal Resistance^[3]

(V_{dd} = 2.7 V, I_{dd} = 6mA), θ_{jc} = 133.3°C/W

Notes:

1. Operation of this device in excess of any of these limits may cause permanent damage.
2. Assuming DC quiescent conditions.
3. Thermal resistance measured using Infra-Red measurement technique.
4. Board (module belly) temperature T_B is 25°C. Derate 7.5 mW/°C for T_B > 142°C.

Product Consistency Distribution Charts^[5,6]

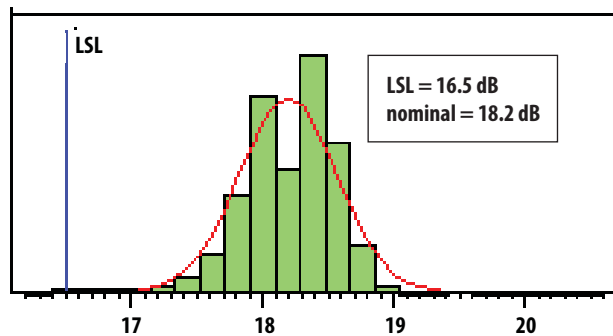

Figure 1. Gain at 1.575 GHz

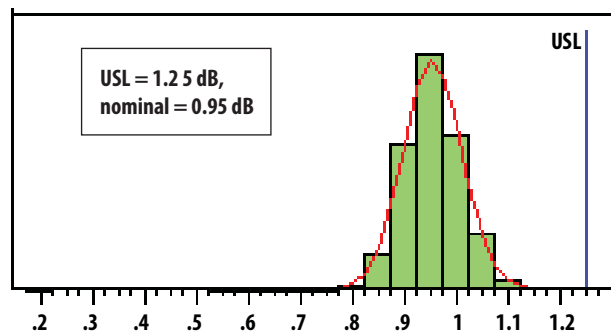

Figure 2. NF at 1.575GHz

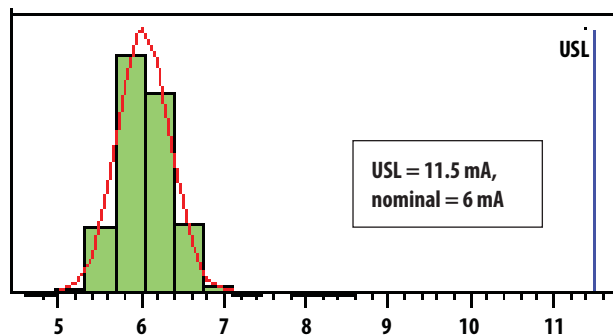

Figure 3. Id at 1.575 GHz

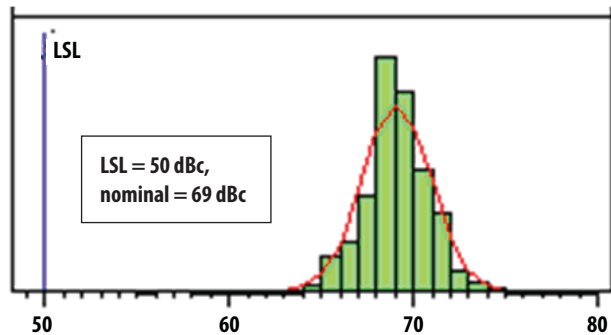

Figure 4. Cell band Rejection at 827.5MHz relative to 1.575 GHz

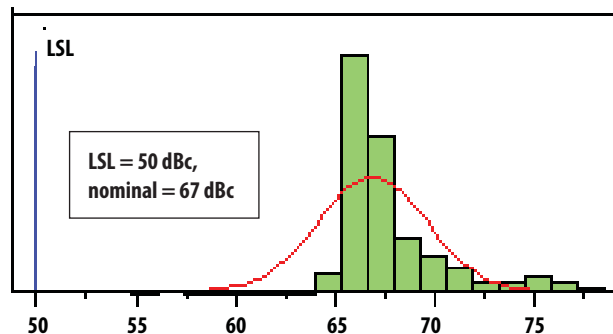

Figure 5. PCS band Rejection at 1885MHz relative to 1.575 GHz

Notes:

5. Distribution data sample size is 5900 samples taken from 7 different LNA wafer lots and 2 different filter wafer lots. Future wafers allocated to this product may have nominal values anywhere between the upper and lower limits.
6. Measurements are made on a production test board, which represents a trade-off between optimal Gain, NF, IIP3, IP1 dB, VSWR, Cell Band and PCS Band Rejection. Circuit trace losses have not been de-embedded from actual measurements.

Electrical Specifications

$T_A = 25^\circ\text{C}$, DC bias for RF parameters is as specified below. Freq=1.575GHz – Typical Performance^[7]

Table 1a. Performance table under nominal operating conditions (Vdd = Vsd 2.7V, Idd = 6mA, R2 = 3.9 kOhm)

Symbol	Parameter and Test Condition	Units	Min.	Typ.	Max.
G	Gain	dB	16.5	18.2	-
NF	Noise Figure	dB	-	0.95	1.25
IP1dB	Input 1dB Compressed Power	dBm	-	-8	-
IIP3 ^[2]	Input 3rd Order Intercept Point (2-tone @ Fc +/- 2.5MHz)	dBm	-	+2	-
S11	Input Return Loss	dB	-	-9	-
S22	Output Return Loss	dB	-	-14	-
S12	Reverse Isolation	dB	-	-27	-
Cell Band Rejection	Relative to 1.575GHz @ 827.5MHz	dBc	50	69	-
PCS Band Rejection	Relative to 1.575GHz @ 1885MHz	dBc	50	67	-
IP1dB _{1885MHz}	Input 1dB gain compression interferer signal level at 1885MHz	dBm	-	-8.0	-
IP1dB _{890MHz}	Input 1dB gain compression interferer signal level at 890MHz	dBm	-	+1.0	-
Idd	Supply DC current at Shutdown (SD) voltage Vsd=2.7V	mA	-	6	11.5
Ish	Shutdown Current @ VSD = 0V	uA	-	0.5	-

Table 1b. Performance table at low voltage operation (Vdd = Vsd 1.8V, Idd = 4mA, R2 = 3.9 kOhm)

Symbol	Parameter and Test Condition	Units	Typ.
G	Gain	dB	16.1
NF	Noise Figure	dB	1.05
IP1dB	Input 1dB Compressed Power	dBm	-8.5
IIP3 ^[8]	Input 3rd Order Intercept Point (2-tone @ Fc +/- 2.5MHz)	dBm	0
S11	Input Return Loss	dB	-7.2
S22	Output Return Loss	dB	-14.5
S12	Reverse Isolation	dB	-28
Cell Band Rejection	Relative to 1.575GHz @ 827.5MHz	dBc	68
PCS Band Rejection	Relative to 1.575GHz @ 1885MHz	dBc	67
IP1dB _{1885MHz}	Input 1dB gain compression interferer signal level at 1885MHz	dBm	-5.0
IP1dB _{890MHz}	Input 1dB gain compression interferer signal level at 890MHz	dBm	0
Idd	Supply DC current at Shutdown (SD) voltage Vsd=1.8V	mA	4
Ish	Shutdown Current @ VSD = 0V	uA	0.5

Notes:

7. Measurements at 1.575GHz obtained using demo board described in Figures 6 and 7

8. 1.575GHz IIP3 test condition: $F_{RF1} = 1572.5 \text{ MHz}$, $F_{RF2} = 1577.5 \text{ MHz}$ with input power of -20dBm per tone measured at the worst case side band

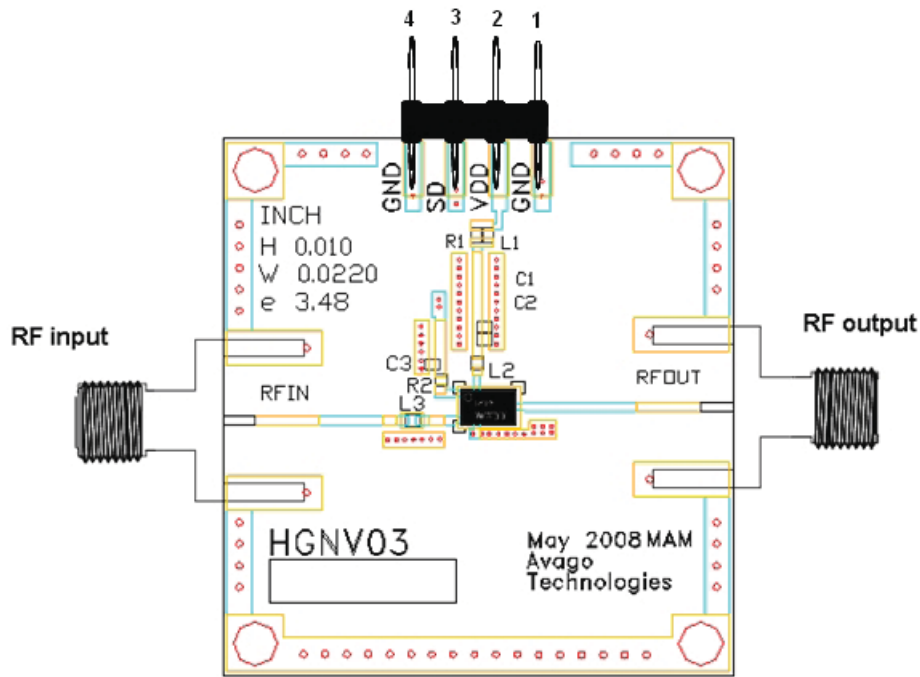

DC Pin Configuration of 4-pin connector

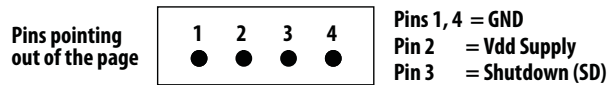

Circuit Symbol	Size	Description
L1	0402	22 nH Inductor (Taiyo Yuden HK100522NJ-T)
L2	0402	2.2 nH Inductor (Taiyo Yuden AQ1052N2S-T)
L3	0402	9.1 nH Inductor (Taiyo Yuden AQ1059N1J-T)
C1	0402	0.1 uF Capacitor (Murata GRM155F51C104ZA01E)
C2	0402	47 pF Capacitor (Murata GRM1555C1H470JZ01D)
C3	0402	330 pF Capacitor (Murata GRM1555C1H331JA01D)
R1	0402	10 Ohms Resistor (KOA RK73B1ETTB100J)
R2	0402	3.9 kOhm Resistor (KOA RK73B1ETTB392J)

Figure 6. Demoboard and application circuit components table

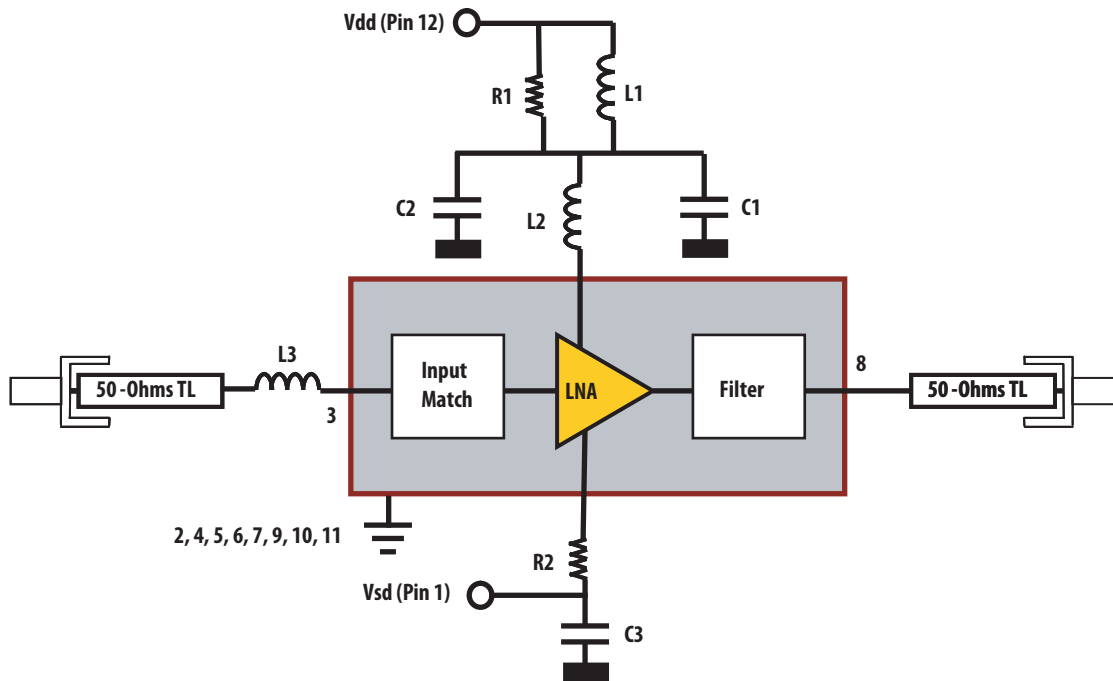

Figure 7. Demoboard and application schematic diagram

Notes

- L3 and the module's internal input pre-match form the input matching network. The RFin pin, pin 3, is directly connected to a shunt inductor that is grounded. The RF output filter blocks DC. Best noise performance is obtained using high-Q wirewound inductors. This circuit demonstrates that low noise figures are obtainable with standard 0402 chip inductors. Replacing L2 and L3 with high-Q wirewound inductors (eg. Coilcraft 0402CS series) will yield lower NF and higher Gain.
- C2 and L2 form a matching network at the output of the LNA, which can be tuned to optimize gain, output return loss and linearity. For example, higher gain can be obtained by increasing the value of C2 but at the expense of stability.
- L1 and R1 isolates the demoboard from external disturbances during measurement. It is not needed in actual application. Likewise, C1 and C3 mitigate the effect of external noise pickup on the Vdd and SD lines respectively. These components are not required in actual operation.
- The output of the module is internally ac-coupled to pin 8.
- Bias control is achieved by either varying the SD voltage with/ without R2, or fixing the SD voltage to Vdd and adjusting R2 for the desired current. $R2 = 3.9 \text{ k}\Omega$ will result in 6mA when $V_{dd}=V_{sd} = 2.7V$ and 4mA when $V_{dd} = V_{sd} = 1.8V$.

ALM-1612 Typical Performance Curves at 25°

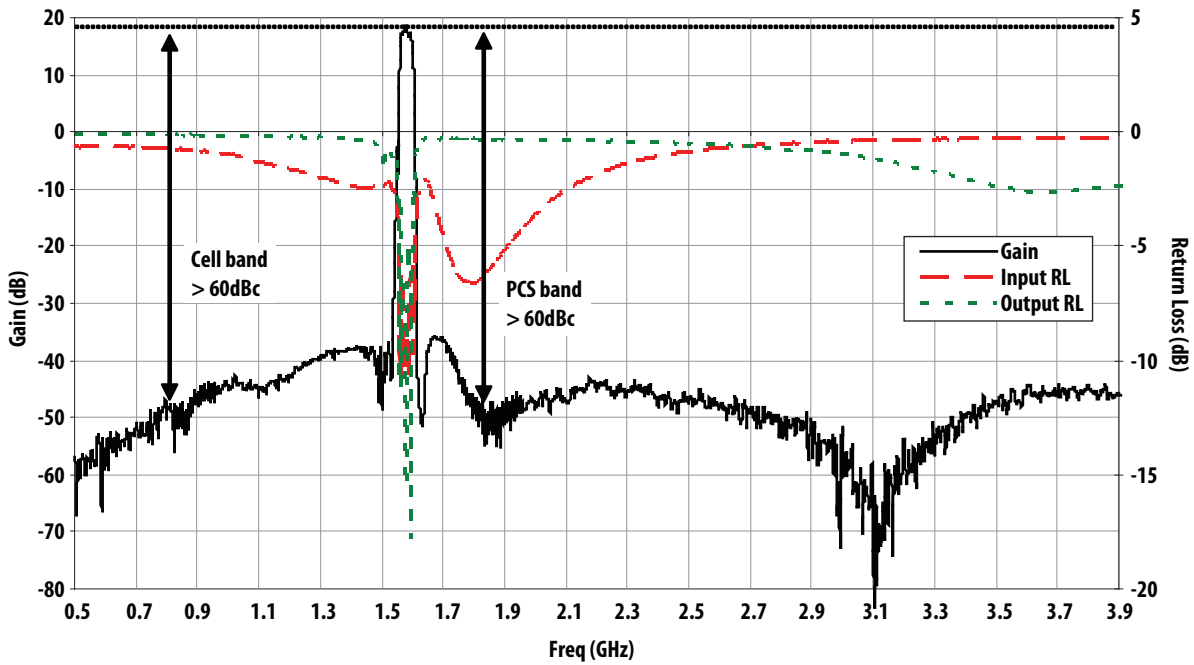

Figure 8a. Typical S-Parameter Plot @ Vdd = 2.7V, Idd = 6mA.

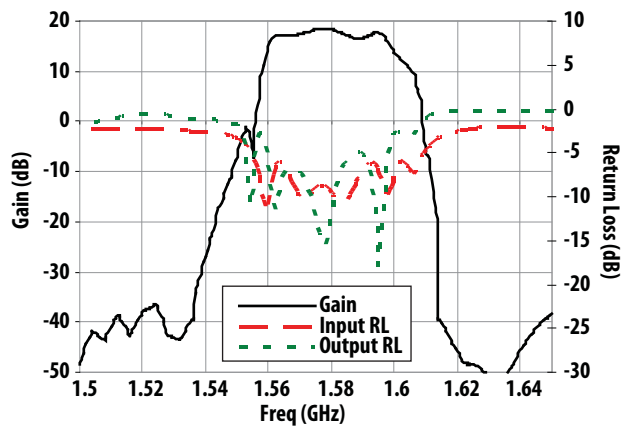

Figure 8b. Passband response of typical S-Parameter Plot @ Vdd = 2.7V, Idd = 6mA

ALM-1612 Typical Performance Curves at 25°

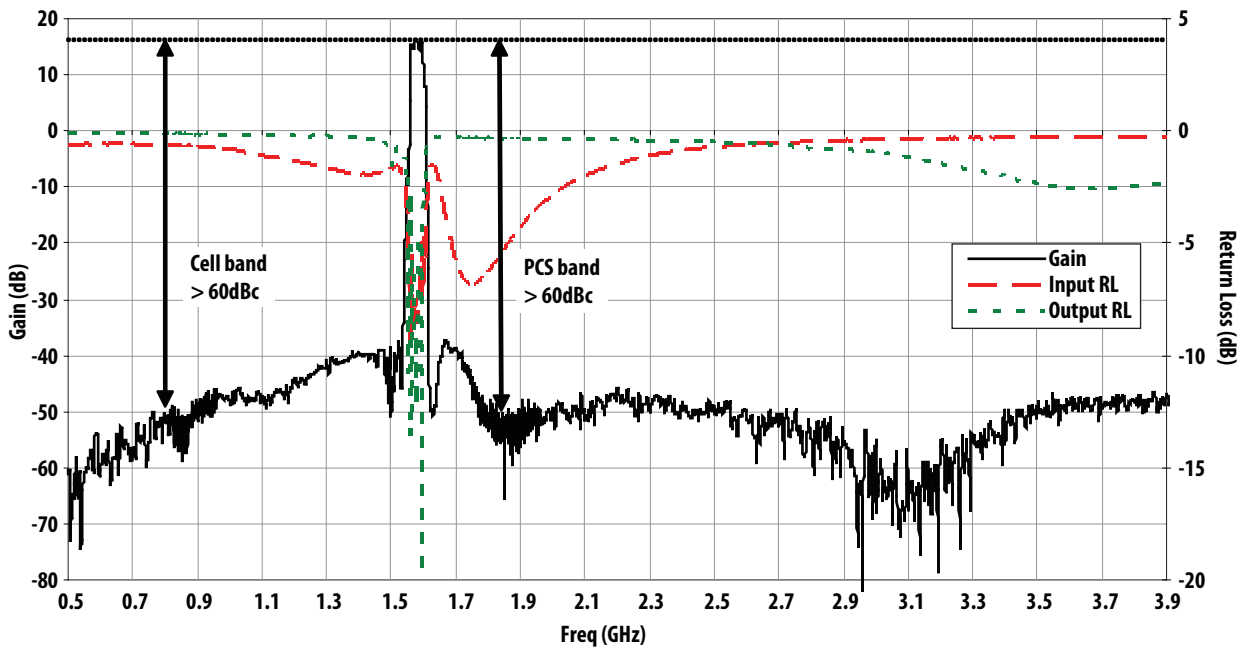

Figure 9a. Typical S-Parameter Plot @ Vdd = 1.8V, Idd = 4mA.

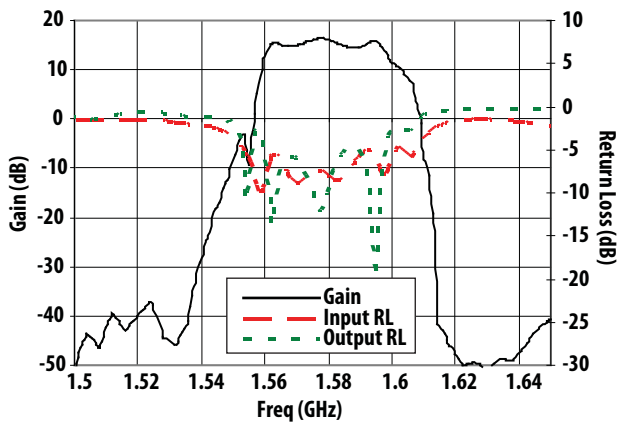

Figure 9b. Passband response of typical S-Parameter Plot @ Vdd = 1.8V, Idd = 4mA

ALM-1612 Typical Performance Curves at 25°C, R2 = 3.9kohm

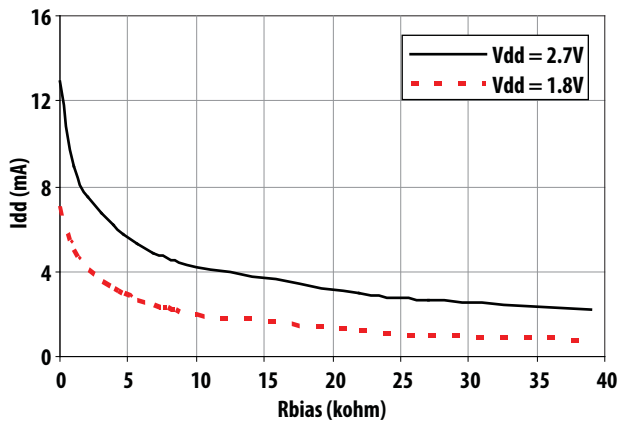

Figure 10. Idd vs Rbias at 25°C

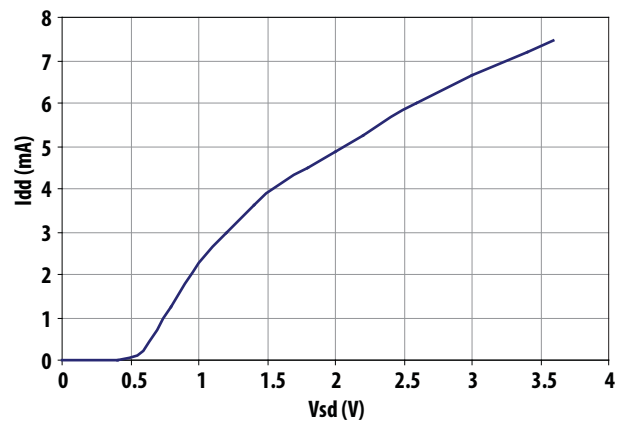

Figure 11. Idd vs Vsd for Vdd = 2.7V, Rbias = 3.9k Ohm

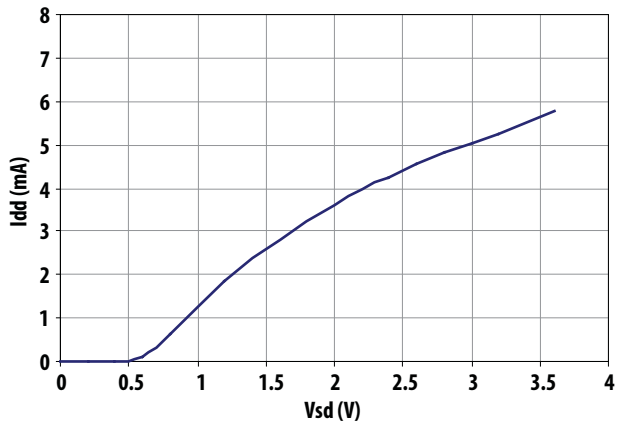

Figure 12. Idd vs Vsd for Vdd = 1.8V, Rbias = 3.9k Ohm

ALM-1612 Typical Performance Curves, R2 = 3.9kohm

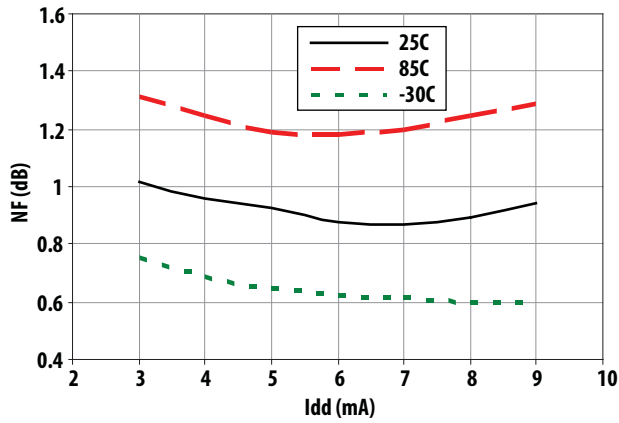

Figure 13. NF vs. Idd at Vdd = 2.7V

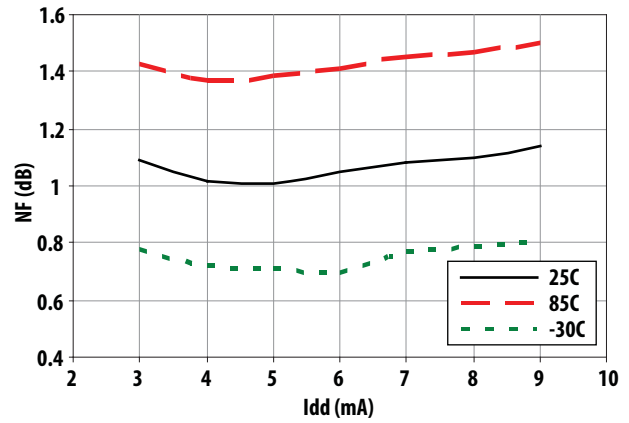

Figure 14. NF vs Idd at Vdd = 1.8V

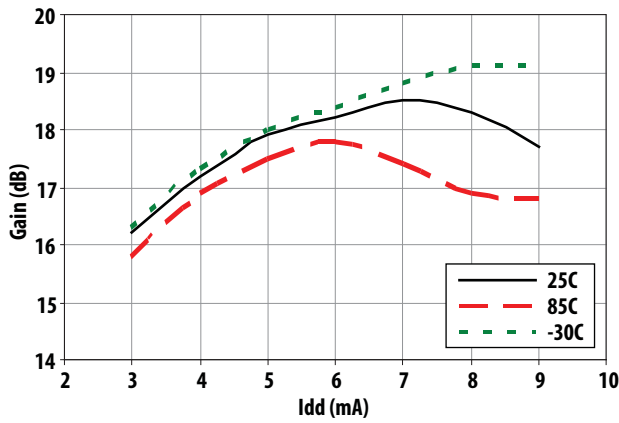

Figure 15. Gain vs. Idd at Vdd = 2.7V

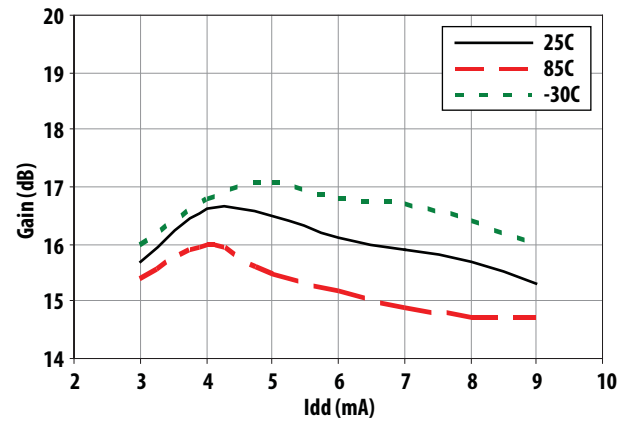

Figure 16. Gain vs. Idd at Vdd = 1.8V

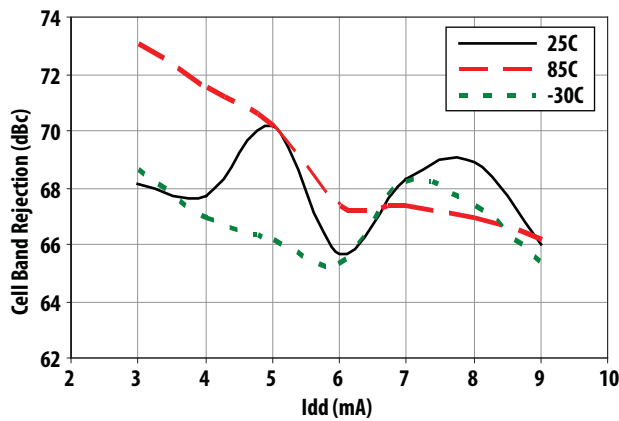

Figure 17. Cell band rejection vs. Idd at Vdd = 2.7V

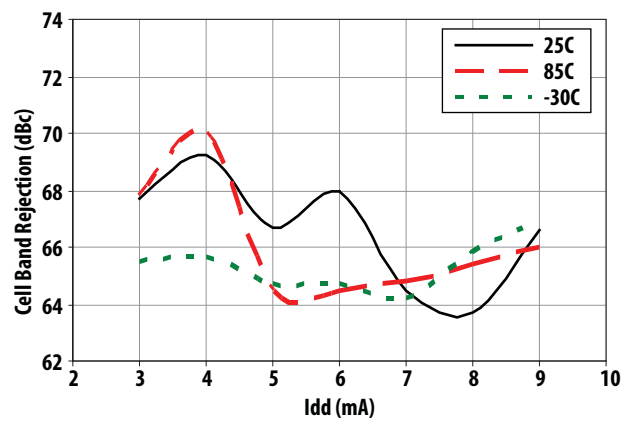

Figure 18. Cell band rejection vs. Idd at Vdd = 1.8V

ALM-1612 Typical Performance Curves, R2 = 3.9kohm

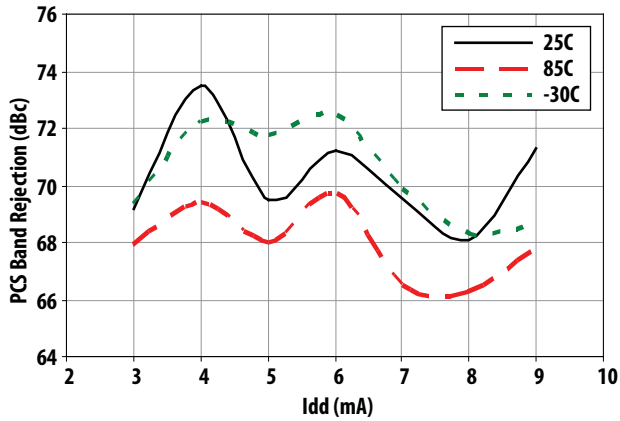

Figure 19. PCS band rejection vs. Idd at Vdd = 2.7V

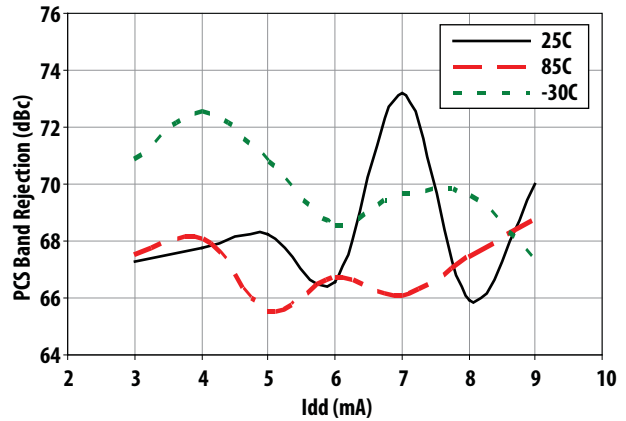

Figure 20. PCS band rejection vs. Idd at Vdd = 1.8V

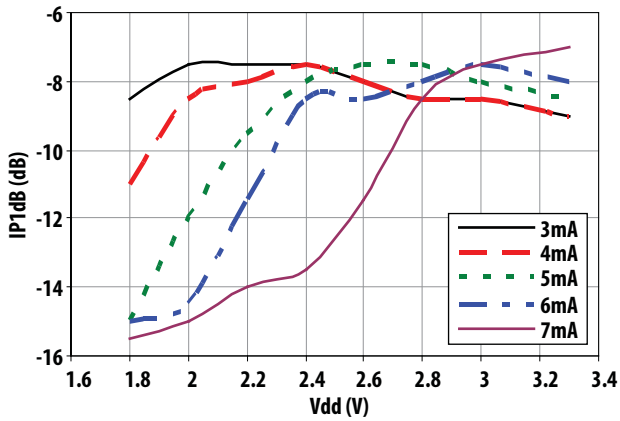

Figure 21. IP1dB vs. Vdd at 25°C

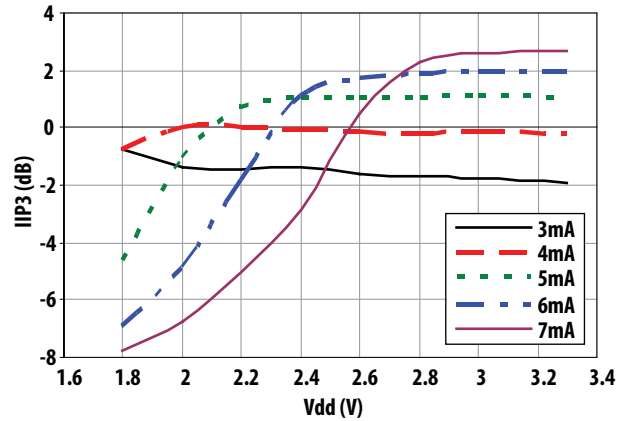

Figure 22. IIP3 vs. Vdd at 25°C

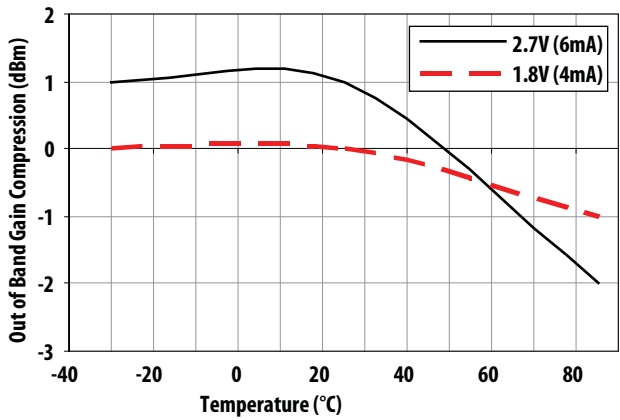

Figure 23. Input signal required at 890MHz interference signal to cause 1dB gain compression at 1.575GHz

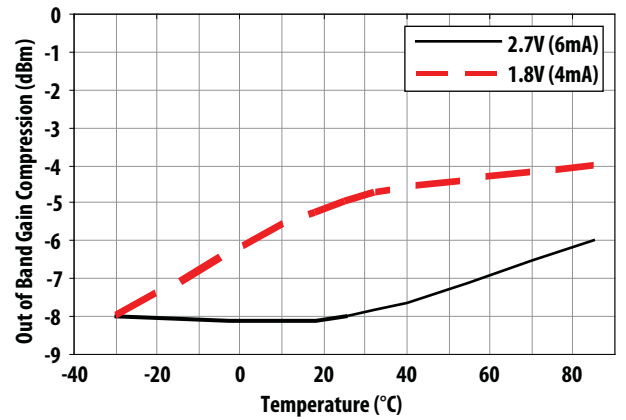

Figure 24. Input signal required at 1885MHz interference signal to cause 1dB gain compression at 1.575GHz

ALM-1612 Typical Performance Curves at 25°C, R2 = 3.9 kohm

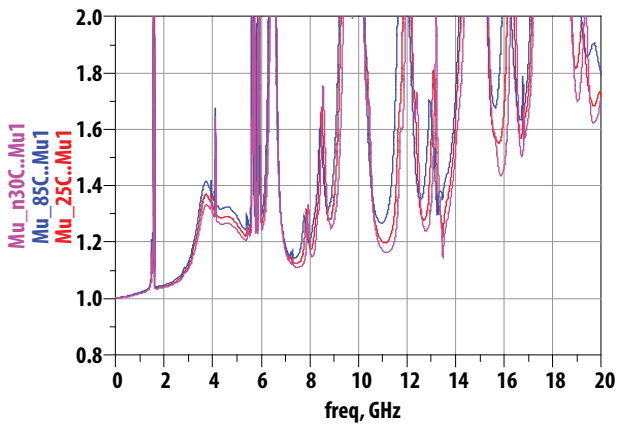

Figure 25. Edwards-Sinsky Output Stability Factor (Mu) at Vdd = 2.7V

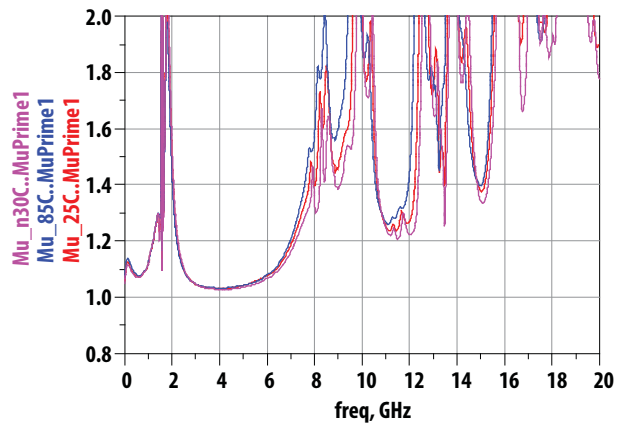

Figure 26. Edwards-Sinsky Input Stability Factor (Mu') at Vdd = 2.7V

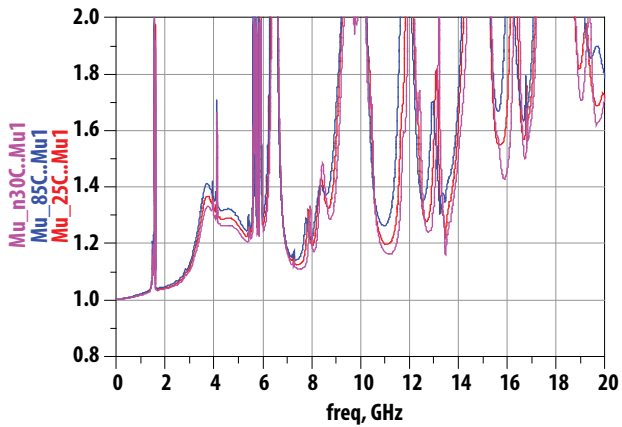

Figure 27. Edwards-Sinsky Output Stability Factor (Mu) at Vdd = 1.8V

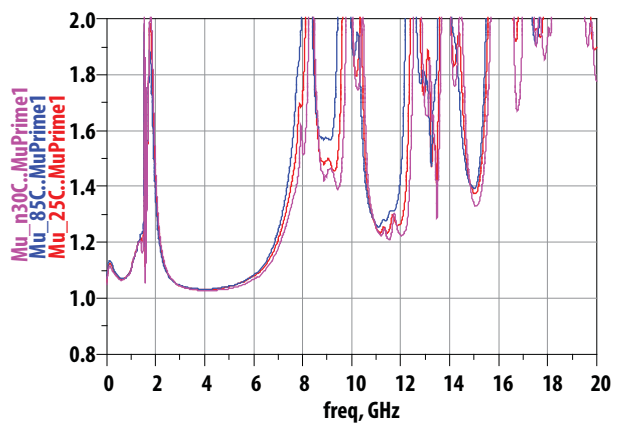

Figure 28. Edwards-Sinsky Input Stability Factor (Mu') at Vdd = 1.8V

ALM-1612 Scattering Parameter and Measurement Reference Planes

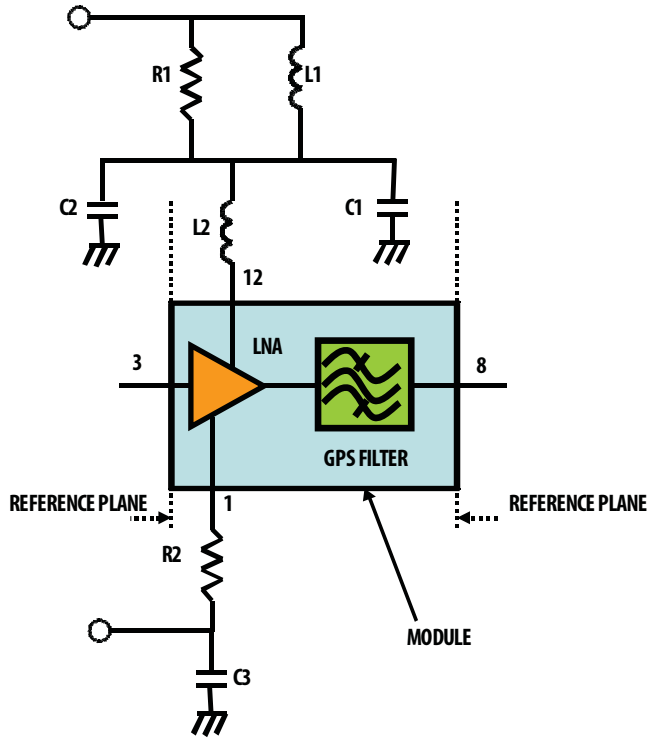

Figure 29. Scattering parameter measurement reference planes

ALM-1612 Scattering Parameter Measurement with Vdd = 2.7V, Idd = 6mA, L2 = 2.2nH Inductor (Taiyo Yuden AQ1052N2S-T)

The S- and Noise Parameters are measured using a microstrip PCB with 10 mils Rogers® RO4350. Figure 29 shows the input and output reference planes. The circuit values, with the exception of L3 are as indicated in Figure 6.

Freq (GHz)	S11	S11	S21	S21	S12	S12	S22	S22
	Mag.	Ang.	Mag.	Ang.	Mag.	Ang.	Mag.	Ang.
0.1	0.9011	133.8906	0.0002	162.4060	0.0003	-160.2437	0.9977	-3.2200
0.2	0.8980	99.6744	0.0001	49.2316	0.0002	172.0262	0.9957	-6.4314
0.3	0.9126	74.6020	0.0004	23.3848	0.0001	-162.4954	0.9927	-9.6559
0.4	0.9241	56.4170	0.0008	3.7308	0.0000	109.1453	0.9942	-13.2123
0.5	0.9273	42.1121	0.0013	-1.1644	0.0001	145.2972	0.9928	-16.6106
0.6	0.9278	30.8024	0.0019	-12.2284	0.0000	139.2982	0.9919	-20.0765
0.7	0.9269	21.5111	0.0026	-22.2183	0.0001	104.0626	0.9906	-23.5842
0.8	0.9253	13.6464	0.0035	-31.0402	0.0001	66.4424	0.9886	-27.2216
0.8275	0.9249	11.6861	0.0037	-32.7566	0.0000	90.4991	0.9878	-28.2619
0.9	0.9233	6.8022	0.0046	-40.1241	0.0000	76.5968	0.9864	-30.9806
1.0	0.9215	0.6024	0.0059	-50.2759	0.0000	142.3765	0.9847	-34.9112
1.1	0.9121	-7.1807	0.0070	-65.5288	0.0000	-62.4462	0.9876	-36.6507
1.2	0.9043	-12.1974	0.0066	-71.6486	0.0000	-144.6072	0.9846	-41.2440
1.3	0.9088	-17.0041	0.0080	-73.5260	0.0001	-124.2978	0.9802	-46.6048
1.4	0.9229	-22.3355	0.0092	-79.8967	0.0001	-146.3362	0.9697	-54.1724
1.5	0.9484	-30.3868	0.0044	-52.7930	0.0004	-146.8740	0.8535	-72.8194
1.575	0.8063	-34.3512	5.0546	-107.4403	0.0211	-137.5272	0.2315	-166.2251
1.6	0.8577	-30.6951	2.9376	-37.2565	0.0121	-64.9184	0.7248	30.4754
1.7	0.7366	-49.8667	0.0139	-172.7375	0.0002	-178.5973	0.9710	-43.7009
1.8	0.6637	-41.2810	0.0052	162.7898	0.0003	172.8707	0.9679	-53.8307
1.885	0.6802	-40.6629	0.0024	-145.1663	0.0003	-164.1941	0.9650	-59.6027
1.9	0.6826	-40.8099	0.0025	-130.1838	0.0003	-176.7934	0.9650	-60.5616
2.0	0.6912	-42.8826	0.0048	-105.3196	0.0004	-172.9826	0.9627	-66.5227
2.1	0.6915	-45.6692	0.0066	-105.7879	0.0006	-163.8139	0.9605	-72.2160
2.2	0.6878	-48.5894	0.0082	-109.2695	0.0007	-166.6162	0.9576	-77.9044
2.3	0.6814	-51.7149	0.0092	-115.1088	0.0008	-178.4480	0.9548	-83.6658
2.4	0.6739	-54.8193	0.0101	-119.9899	0.0008	-176.8636	0.9518	-89.5453
2.5	0.6655	-57.9923	0.0105	-125.8088	0.0010	178.2377	0.9486	-95.6380
3.0	0.6258	-74.1391	0.0060	-146.8467	0.0016	157.3313	0.9291	-130.4831
3.5	0.6077	-89.8611	0.0284	-33.6772	0.0027	116.9722	0.8618	174.5646
4.0	0.6141	-103.0407	0.1301	-106.6236	0.0033	15.9666	0.6586	34.4266
4.5	0.6333	-112.0169	0.1545	-170.9774	0.0039	-80.7080	0.8365	-82.7483
5.0	0.6534	-116.7876	0.1731	155.6017	0.0063	-108.7870	0.8886	-125.4567
6.0	0.6467	-123.5441	0.2073	115.1264	0.0190	-118.1782	0.7884	-155.7150
7.0	0.5886	-135.9739	0.0997	-46.3875	0.0381	104.0196	0.8321	-144.2912
8.0	0.6385	-172.5148	0.1043	1.2566	0.0319	177.8397	0.8484	140.6174
9.0	0.5774	144.8882	0.1155	114.0135	0.1716	27.8864	0.8736	121.7759
10.0	0.3742	175.4429	0.0445	-28.6075	0.0467	-48.6952	0.8166	112.5356
11.0	0.3056	150.3862	0.0912	8.1618	0.0960	-3.5172	0.8299	71.2884
12.0	0.2181	174.0406	0.0957	-62.9113	0.0996	-71.9903	0.7125	46.6607
13.0	0.3654	-137.3695	0.1166	-98.9524	0.1335	-107.4183	0.8320	16.2948
14.0	0.6930	173.0097	0.0942	-152.1249	0.1230	-166.3571	0.8440	-8.9180
15.0	0.8560	124.4684	0.0553	177.3663	0.0843	146.8316	0.8323	-29.5940
16.0	0.9184	97.3077	0.0456	172.3875	0.0543	116.8732	0.7788	-64.3523
17.0	0.9213	76.6553	0.0500	164.4238	0.0258	102.6632	0.6829	-143.0165
18.0	0.8832	46.8002	0.0601	143.0559	0.0393	138.1294	0.7659	137.6027
19.0	0.7924	11.8101	0.0673	103.4993	0.0696	89.2434	0.7953	73.8127
20.0	0.9023	-19.2639	0.0532	91.8400	0.0615	60.3323	0.8491	22.1366

ALM-1612 Scattering Parameter Measurement with Vdd = 1.8V, Idd = 4mA, L2 = 2.2nH Inductor (Taiyo Yuden AQ1052N2S-T)

Freq (GHz)	S11	S11	S21	S21	S12	S12	S22	S22
	Mag.	Ang.	Mag.	Ang.	Mag.	Ang.	Mag.	Ang.
0.1	0.9014	133.9390	0.0002	144.6375	0.0001	140.1618	0.9978	-3.2184
0.2	0.8999	99.6634	0.0001	-57.2546	0.0001	125.9008	0.9956	-6.4408
0.3	0.9163	74.6107	0.0001	8.4159	0.0001	-151.8508	0.9927	-9.6661
0.4	0.9294	56.3981	0.0004	17.2949	0.0000	-68.3960	0.9942	-13.2328
0.5	0.9341	42.0617	0.0009	0.6865	0.0001	125.0121	0.9928	-16.6305
0.6	0.9362	30.6904	0.0012	-11.8292	0.0001	28.9504	0.9918	-20.0899
0.7	0.9370	21.3498	0.0018	-19.8628	0.0000	123.0281	0.9905	-23.6103
0.8	0.9368	13.4083	0.0024	-27.4617	0.0001	70.6606	0.9886	-27.2527
0.8275	0.9368	11.4275	0.0026	-27.6460	0.0001	134.2380	0.9878	-28.2910
0.9	0.9362	6.4782	0.0032	-34.5340	0.0002	-104.9196	0.9863	-31.0074
1.0	0.9356	0.2054	0.0042	-45.3717	0.0001	-154.0931	0.9848	-34.9434
1.1	0.9271	-7.6247	0.0051	-60.8247	0.0000	-171.5592	0.9876	-36.6880
1.2	0.9210	-12.7981	0.0048	-67.0944	0.0000	61.3205	0.9846	-41.2850
1.3	0.9251	-17.7188	0.0060	-67.8615	0.0001	-154.3034	0.9802	-46.6408
1.4	0.9388	-23.0717	0.0071	-75.3642	0.0002	-143.7797	0.9696	-54.2174
1.5	0.9647	-31.2214	0.0037	-50.4929	0.0003	-161.5621	0.8534	-72.8634
1.575	0.8343	-34.1755	3.6932	-109.2937	0.0230	-147.2273	0.3350	-175.5357
1.6	0.8818	-31.8885	2.2220	-34.2096	0.0136	-69.5840	0.7331	27.4056
1.7	0.7417	-45.3283	0.0095	176.4327	0.0002	-162.3618	0.9710	-43.7489
1.8	0.7337	-41.0048	0.0033	161.3556	0.0002	178.2060	0.9679	-53.8854
1.885	0.7448	-42.4662	0.0016	-142.8030	0.0004	-174.1026	0.9650	-59.6501
1.9	0.7457	-42.8365	0.0018	-128.5098	0.0004	-169.4542	0.9650	-60.6137
2.0	0.7478	-45.8473	0.0034	-103.7281	0.0004	-159.3585	0.9628	-66.5732
2.1	0.7433	-49.2546	0.0048	-103.7389	0.0006	-159.3276	0.9605	-72.2634
2.2	0.7365	-52.6817	0.0059	-107.6328	0.0006	-166.8025	0.9575	-77.9626
2.3	0.7273	-56.2590	0.0068	-113.3094	0.0007	-172.7269	0.9547	-83.7315
2.4	0.7173	-59.8054	0.0073	-118.1646	0.0009	-176.3840	0.9518	-89.6052
2.5	0.7067	-63.4121	0.0078	-123.9088	0.0011	-170.7909	0.9486	-95.6964
3.0	0.6556	-81.5348	0.0048	-147.8666	0.0018	155.2566	0.9289	-130.5755
3.5	0.6245	-98.6153	0.0209	-31.0252	0.0029	112.8778	0.8617	174.4766
4.0	0.6153	-112.2833	0.0995	-105.1721	0.0037	13.4278	0.6583	34.2996
4.5	0.6154	-121.0594	0.1202	-170.4479	0.0042	-81.0704	0.8363	-82.9208
5.0	0.6141	-125.2191	0.1363	154.9150	0.0071	-108.6404	0.8882	-125.6518
6.0	0.5700	-131.0511	0.1609	110.6471	0.0223	-120.9389	0.7849	-156.1253
7.0	0.4744	-143.6596	0.0660	-54.7179	0.0434	96.3475	0.8321	-144.6875
8.0	0.4515	167.7910	0.0787	-51.2484	0.0436	157.9946	0.8379	140.8050
9.0	0.3286	138.4936	0.1554	58.6481	0.1658	9.4260	0.8351	120.2698
10.0	0.5025	176.8214	0.0323	-22.5398	0.0287	-43.3654	0.8177	112.3089
11.0	0.3409	158.3015	0.0987	7.3298	0.0823	2.0696	0.8304	70.9087
12.0	0.2763	171.3689	0.0977	-61.6828	0.0903	-65.6062	0.7116	46.3559
13.0	0.3144	-142.3535	0.1251	-95.9315	0.1316	-101.6738	0.8299	16.0130
14.0	0.6675	173.8507	0.1062	-151.3318	0.1247	-164.2497	0.8418	-9.0788
15.0	0.8476	124.7610	0.0672	174.7685	0.0850	147.4447	0.8311	-29.7012
16.0	0.9152	97.0739	0.0533	159.9537	0.0546	116.6987	0.7775	-64.5392
17.0	0.9148	75.8350	0.0484	148.4729	0.0264	99.9913	0.6825	-143.2780
18.0	0.8676	45.5628	0.0543	136.3047	0.0365	136.0207	0.7655	137.2866
19.0	0.7662	10.5320	0.0669	99.2020	0.0652	88.9409	0.7945	73.4128
20.0	0.8720	-19.9148	0.0555	84.0075	0.0573	61.5727	0.8484	21.7248

ALM-1612 Typical Noise Parameters

25°C, Freq = 1.575 GHz, Vdd = 2.7V, Idd = 6mA

Freq (GHz)	Fmin (dB)	GAMMA OPT		
		Mag	Ang	Rn/50
1.575	0.77	0.58	31	0.38

ALM-1612 Typical Noise Parameters

25°C, Freq = 1.575 GHz, Vdd = 1.8V, Idd = 4mA

Freq (GHz)	Fmin (dB)	GAMMA OPT		
		Mag	Ang	Rn/50
1.575	1.05	0.63	30	0.54

Note:

The exceptional noise figure performance of the ALM-1612 is due to its highly optimized design. In this regard, the Fmin of the ALM-1612 shown above is locked down by the internal input pre-match. This allows the use of relatively inexpensive chip inductors for external matching.

Package Dimensions

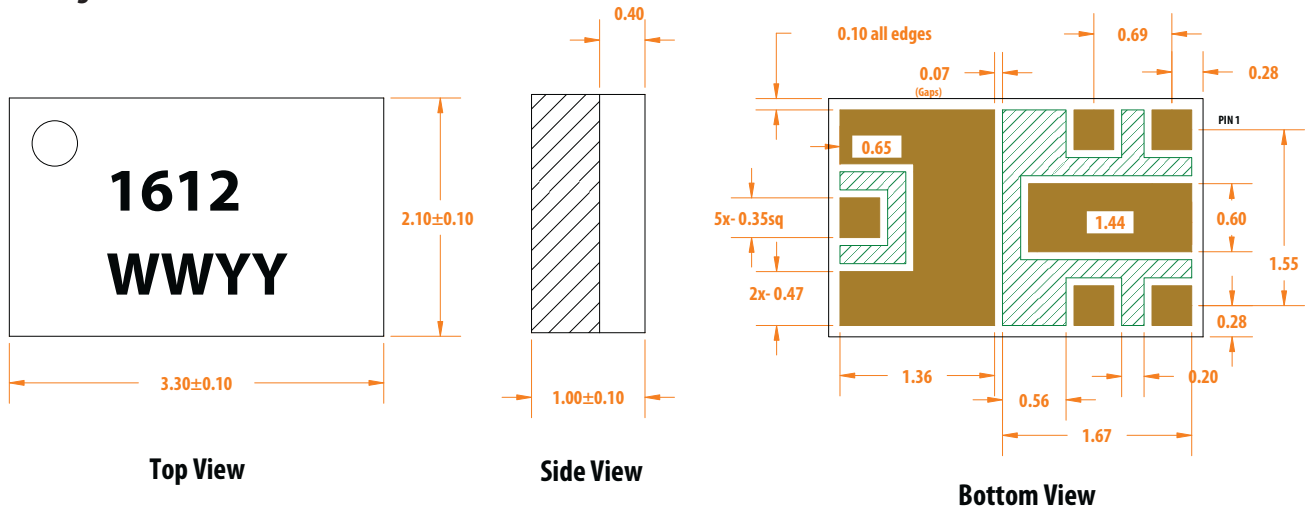

Notes:

1. All dimensions are in millimeters.
2. Dimensions are inclusive of plating.
3. Dimensions are exclusive of mold flash and metal burr.

PCB Land Patterns and Stencil Design

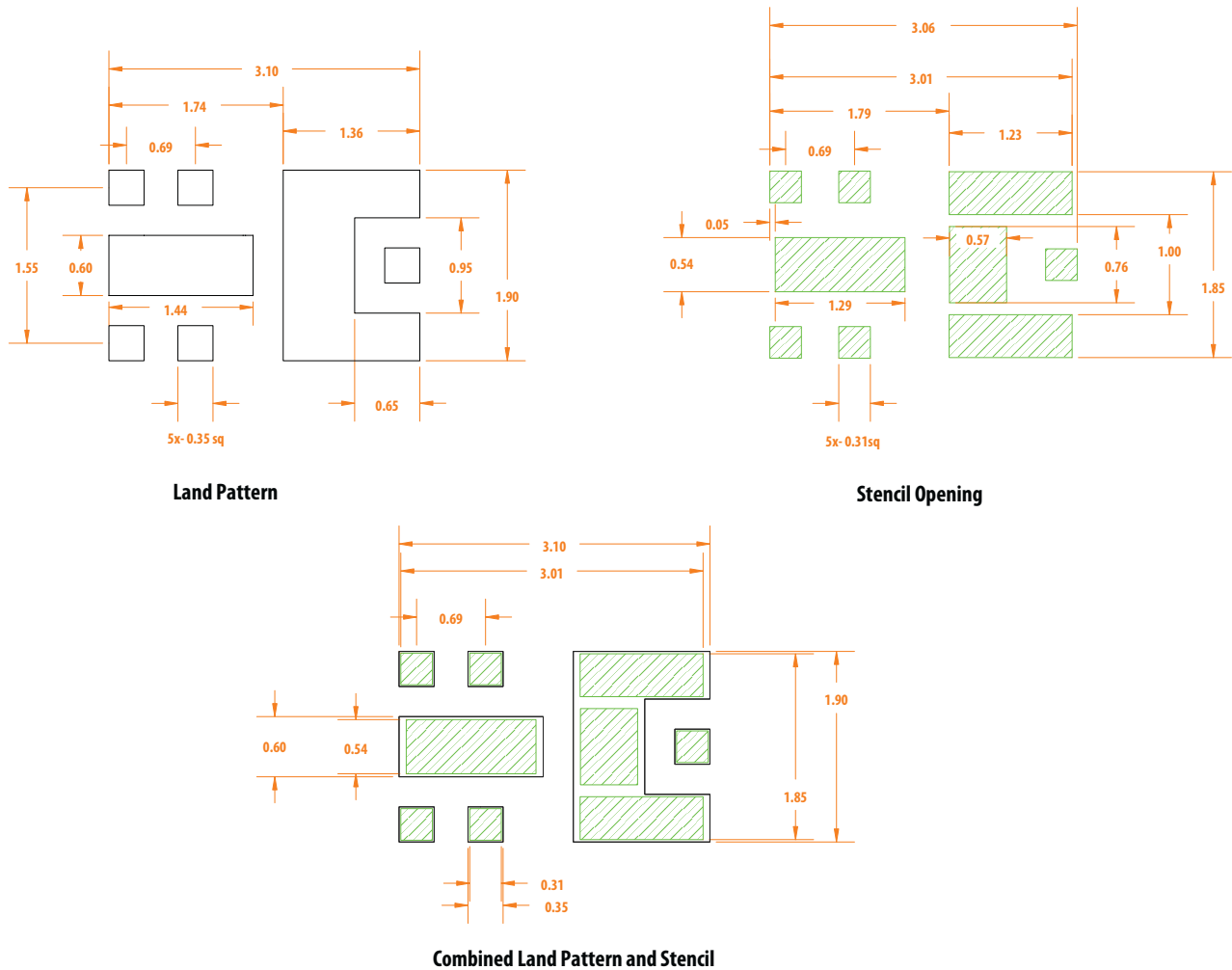

Dimensions are in mm

Device Orientation

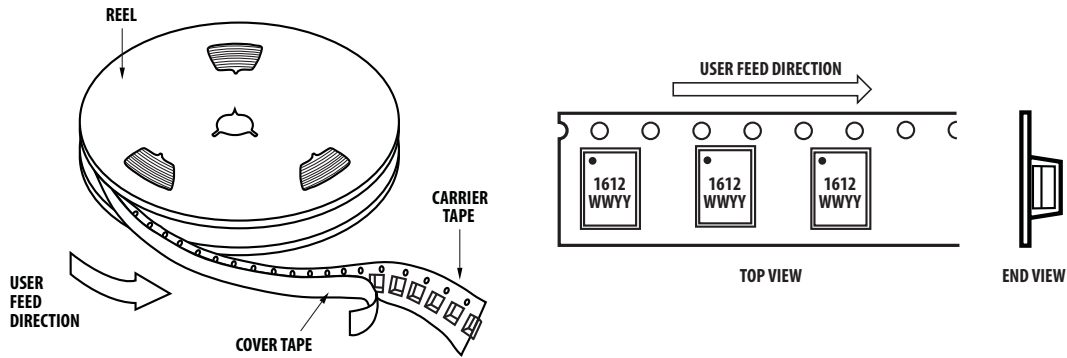

Tape Dimensions (all dimension in mm)

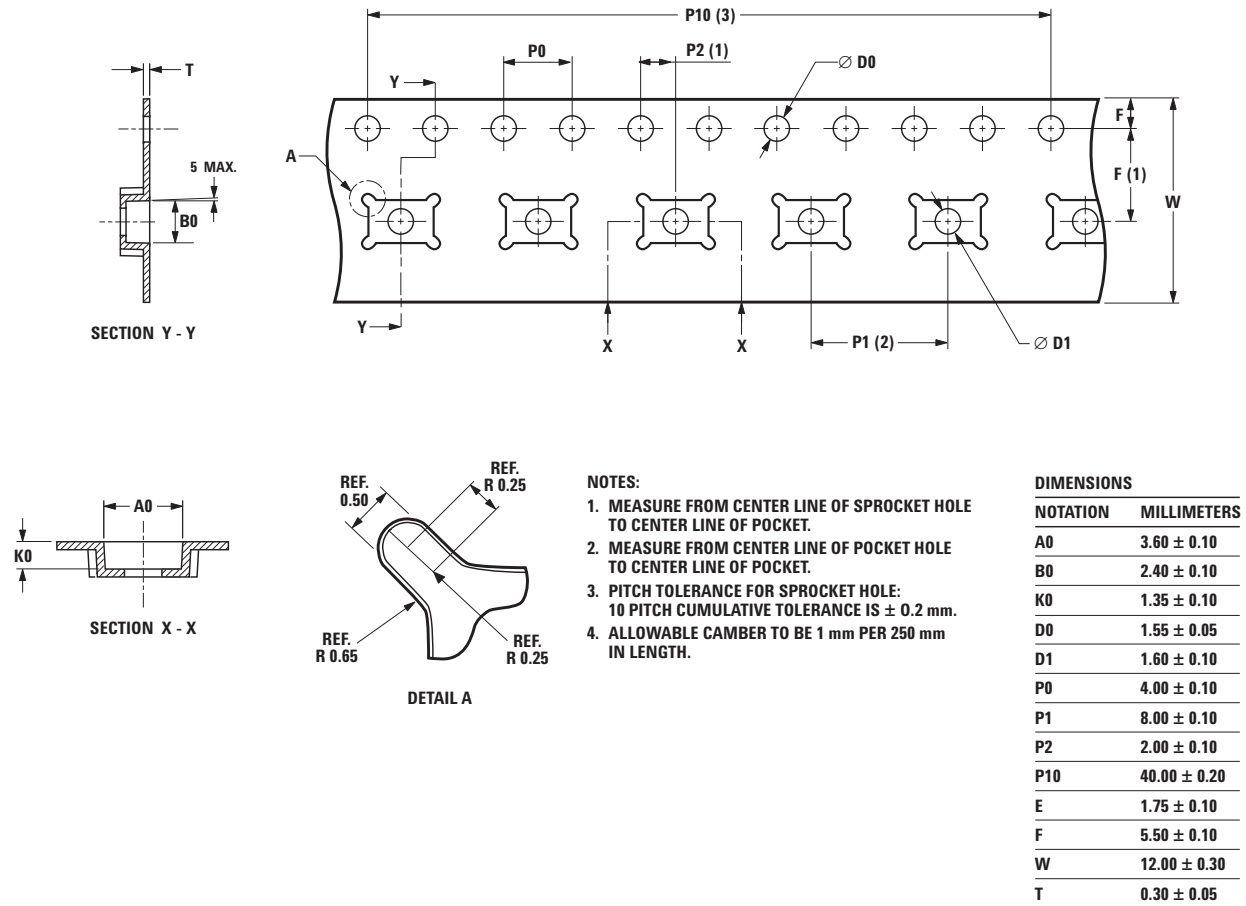

Part Number Ordering Information

Part #	Qty	Container
ALM-1612-BLKG	100	Antistatic Bag
ALM-1612-TR1G	3000	13" Reel

Reel Dimensions (13" reel)

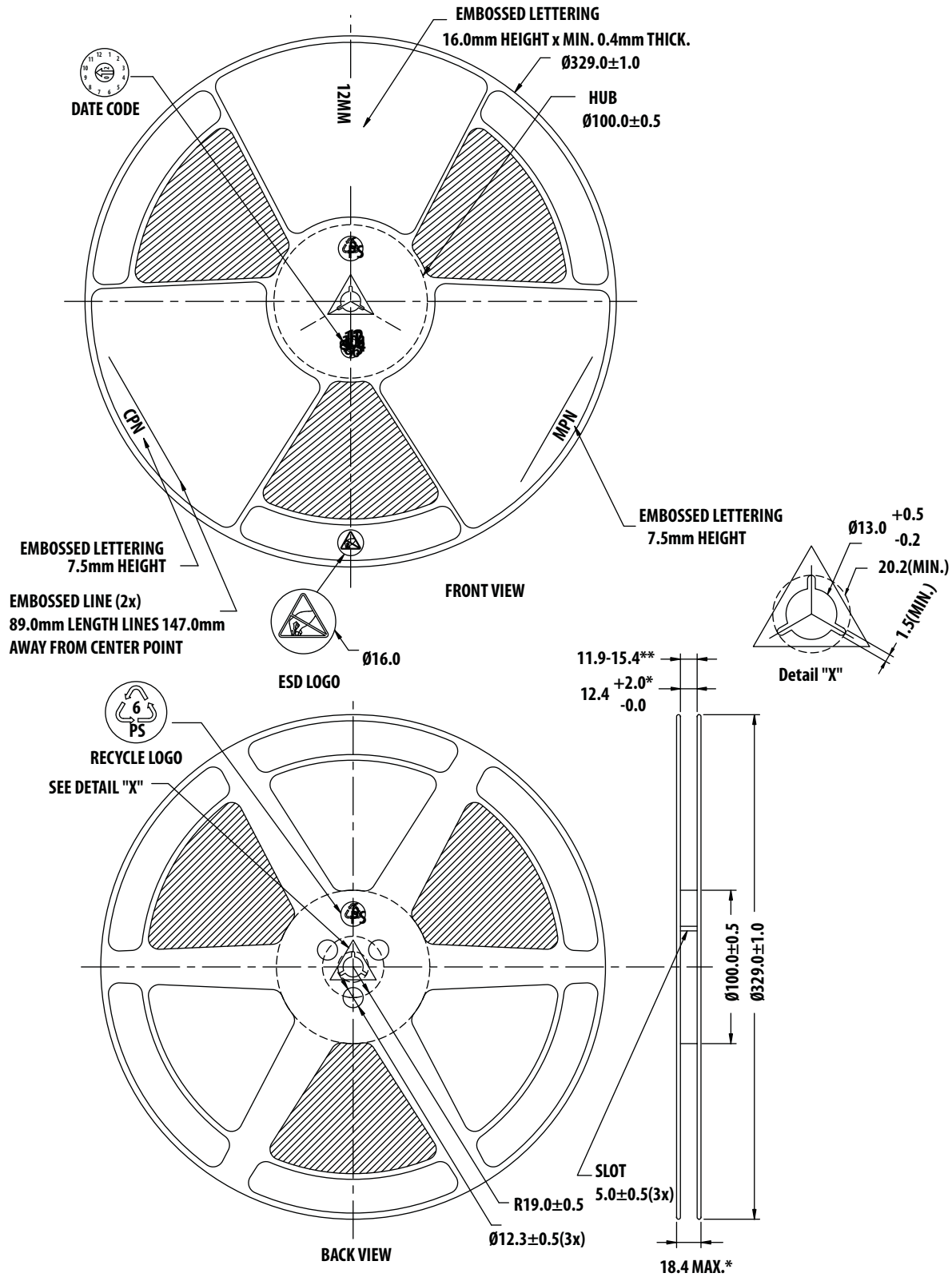

For product information and a complete list of distributors, please go to our web site: www.avagotech.com

Avago, Avago Technologies, and the A logo are trademarks of Avago Technologies in the United States and other countries. Data subject to change. Copyright © 2005-2010 Avago Technologies. All rights reserved. AV02-1463EN - February 5, 2010

