

# MSA-0286

## Cascadable Silicon Bipolar MMIC Amplifier



### Data Sheet

#### Description

The MSA-0286 is a high performance silicon bipolar Monolithic Microwave Integrated Circuit (MMIC) housed in a low cost, surface mount plastic package. This MMIC is designed for use as a general purpose 50Ω gain block. Typical applications include narrow and broad band IF and RF amplifiers in commercial and industrial applications.

The MSA-series is fabricated using Avago's 10 GHz  $f_T$ , 25 GHz  $f_{MAX}$ , silicon bipolar MMIC process which uses nitride self-alignment, ion implantation, and gold metallization to achieve excellent performance, uniformity and reliability. The use of an external bias resistor for temperature and current stability also allows bias flexibility.

#### Features

- Cascadable 50 Ω Gain Block
- 3 dB Bandwidth: DC to 2.5 GHz
- 12.0 dB Typical Gain at 1.0 GHz
- Unconditionally Stable ( $k > 1$ )
- Surface Mount Plastic Package
- Tape-and-Reel Packaging Option Available
- Lead-free Option Available

#### 86 Plastic Package

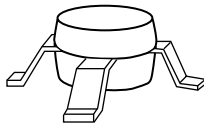

#### Typical Biasing Configuration

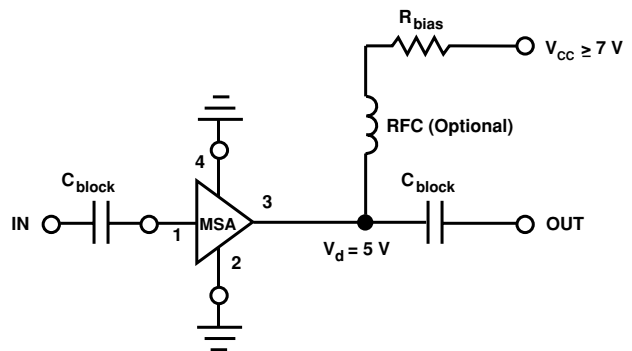

### MSA-0286 Absolute Maximum Ratings

| Parameter                          | Absolute Maximum <sup>[1]</sup> |
|------------------------------------|---------------------------------|
| Device Current                     | 60 mA                           |
| Power Dissipation <sup>[2,3]</sup> | 325 mW                          |
| RF Input Power                     | +13 dBm                         |
| Junction Temperature               | 150°C                           |
| Storage Temperature                | -65 to 150°C                    |

#### Thermal Resistance<sup>[2]:</sup>

$$\theta_{jc} = 105^{\circ}\text{C/W}$$

#### Notes:

1. Permanent damage may occur if any of these limits are exceeded.
2.  $T_{\text{CASE}} = 25^{\circ}\text{C}$ .
3. Derate at  $9.5 \text{ mW}/^{\circ}\text{C}$  for  $T_{\text{C}} > 116^{\circ}\text{C}$ .

### Electrical Specifications<sup>[1]</sup>, $T_{\text{A}} = 25^{\circ}\text{C}$

| Symbol                | Parameters and Test Conditions: $I_{\text{d}} = 25 \text{ mA}$ , $Z_{\text{O}} = 50 \Omega$ | Units                        | Min. | Typ.         | Max. |
|-----------------------|---|------------------------------|------|--------------|------|
| $G_{\text{P}}$        | Power Gain ( $ S_{21} ^2$ )<br>$f = 0.1 \text{ GHz}$<br>$f = 1.0 \text{ GHz}$               | dB                           | 10.0 | 12.5<br>12.0 |      |
| $\Delta G_{\text{P}}$ | Gain Flatness<br>$f = 0.1 \text{ to } 1.6 \text{ GHz}$                                      | dB                           |      | $\pm 0.6$    |      |
| $f_{\text{3 dB}}$     | 3 dB Bandwidth  | GHz                          |      | 2.5          |      |
| VSWR                  | Input VSWR<br>$f = 0.1 \text{ to } 3.0 \text{ GHz}$   |                              |      | 1.5:1        |      |
|                       | Output VSWR<br>$f = 0.1 \text{ to } 3.0 \text{ GHz}$  |                              |      | 1.4:1        |      |
| NF                    | 50 $\Omega$ Noise Figure<br>$f = 1.0 \text{ GHz}$   | dB                           |      | 6.5          |      |
| $P_{1 \text{ dB}}$    | Output Power at 1 dB Gain Compression<br>$f = 1.0 \text{ GHz}$                              | dBm                          |      | 4.5          |      |
| $\text{IP}_3$         | Third Order Intercept Point<br>$f = 1.0 \text{ GHz}$  | dBm                          |      | 17.0         |      |
| $t_{\text{D}}$        | Group Delay<br>$f = 1.0 \text{ GHz}$  | psec                         |      | 140          |      |
| $V_{\text{d}}$        | Device Voltage  | V                            | 4.0  | 5.0          | 6.0  |
| $\text{dV}/\text{dT}$ | Device Voltage Temperature Coefficient  | $\text{mV}/^{\circ}\text{C}$ |      | -8.0         |      |

#### Note:

1. The recommended operating current range for this device is 18 to 40 mA. Typical performance as a function of current is on the following page.

### Ordering Information

| Part Numbers  | No. of Devices | Comments |
|---------------|----------------|----------|
| MSA-0286-BLK  | 100            | Bulk     |
| MSA-0286-BLKG | 100            | Bulk     |
| MSA-0286-TR1  | 1000           | 7" Reel  |
| MSA-0286-TR1G | 1000           | 7" Reel  |
| MSA-0286-TR2  | 4000           | 13" Reel |
| MSA-0286-TR2G | 4000           | 13" Reel |

**Note:** Order part number with a "G" suffix if lead-free option is desired.

**MSA-0286 Typical Scattering Parameters ( $Z_0 = 50 \Omega$ ,  $T_A = 25^\circ\text{C}$ ,  $I_d = 25 \text{ mA}$ )**

| Freq.<br>GHz | $S_{11}$ |     | $S_{21}$ |      |     | $S_{12}$ |      |     | $S_{22}$ |      |
|--------------|----------|-----|----------|------|-----|----------|------|-----|----------|------|
|              | Mag      | Ang | dB       | Mag  | Ang | dB       | Mag  | Ang | Mag      | Ang  |
| 0.1          | .10      | 171 | 12.5     | 4.22 | 175 | -18.5    | .119 | 1   | .16      | -5   |
| 0.2          | .10      | 161 | 12.5     | 4.20 | 170 | -18.3    | .121 | 3   | .16      | -11  |
| 0.4          | .10      | 144 | 12.4     | 4.16 | 159 | -18.2    | .122 | 6   | .15      | -24  |
| 0.6          | .09      | 129 | 12.2     | 4.09 | 149 | -18.0    | .126 | 6   | .15      | -36  |
| 0.8          | .08      | 119 | 12.1     | 4.01 | 139 | -18.0    | .127 | 9   | .14      | -48  |
| 1.0          | .08      | 108 | 11.9     | 3.91 | 129 | -17.4    | .135 | 8   | .14      | -62  |
| 1.5          | .06      | 111 | 11.3     | 3.67 | 106 | -16.5    | .149 | 12  | .11      | -99  |
| 2.0          | .08      | 141 | 10.5     | 3.35 | 84  | -15.7    | .164 | 11  | .11      | -141 |
| 2.5          | .14      | 150 | 9.6      | 3.01 | 67  | -14.8    | .182 | 9   | .12      | -176 |
| 3.0          | .21      | 142 | 8.6      | 2.68 | 48  | -14.3    | .194 | 5   | .13      | 155  |
| 3.5          | .29      | 132 | 7.5      | 2.37 | 30  | -14.0    | .200 | 1   | .14      | 140  |
| 4.0          | .36      | 121 | 6.4      | 2.09 | 15  | -13.5    | .211 | -3  | .16      | 134  |
| 5.0          | .50      | 101 | 4.1      | 1.61 | -12 | -13.3    | .216 | -12 | .20      | 132  |

**Typical Performance,  $T_A = 25^\circ\text{C}$** 

(unless otherwise noted)

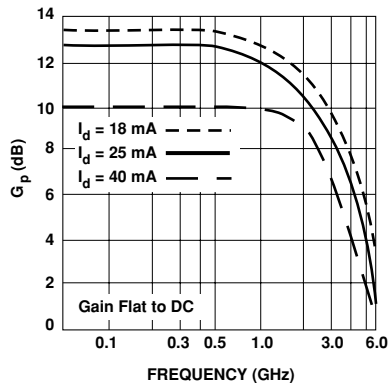
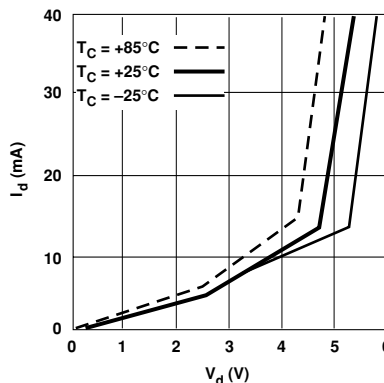
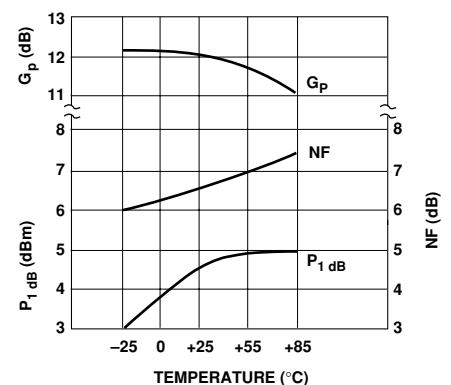
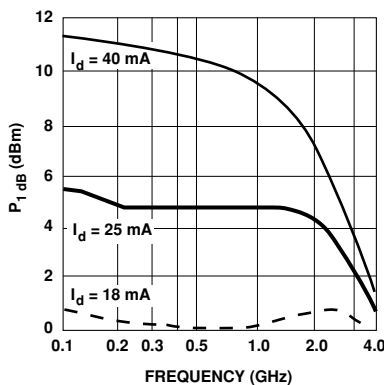
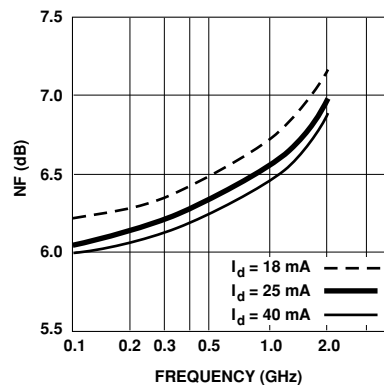
**Figure 1. Typical Power Gain vs. Frequency.**

**Figure 2. Device Current vs. Voltage.**

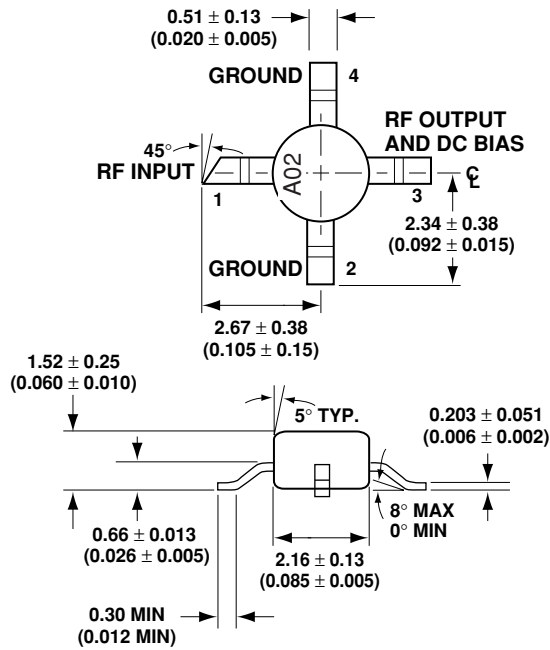
**Figure 3. Output Power at 1 dB Gain Compression, NF and Power Gain vs. Case Temperature,  $f = 1.0 \text{ GHz}$ ,  $I_d = 25 \text{ mA}$ .**

**Figure 4. Output Power at 1 dB Gain Compression vs. Frequency.**

**Figure 5. Noise Figure vs. Frequency.**

## 86 Plastic Package Dimensions



DIMENSIONS ARE IN MILLIMETERS (INCHES)

For product information and a complete list of distributors, please go to our web site:  
[www.avagotech.com](http://www.avagotech.com)

Avago, Avago Technologies, and the A logo are trademarks of Avago Technologies, Limited in the United States and other countries.  
 Data subject to change. Copyright © 2006 Avago Technologies, Limited. All rights reserved.  
 Obsoletes 5965-9564E  
 5989-2749EN September 16, 2006

**AVAGO**  
 TECHNOLOGIES