

ALM-1106

GPS Low Noise amplifier with Variable bias current and Shutdown function



Data Sheet

Description

Avago Technologies's ALM-1106 is a LNA designed for GPS/ISM/Wimax applications in the (0.9-3.5)GHz frequency range. The LNA uses Agilent Technologies's proprietary GaAs Enhancement-mode pHEMT process to achieve high gain operation with very low noise figures and high linearity. Noise figure distribution is very tightly controlled. Gain and supply current are guaranteed parameters. A CMOS compatible shutdown pin is included to turn the LNA off and provide a variable bias.

The ALM-1106 LNA is useable down to 1V operation. It achieves low noise figures and high gain even at 1V, making it suitable for use in critical low power GPS/ISM band applications.

Simplified Schematic

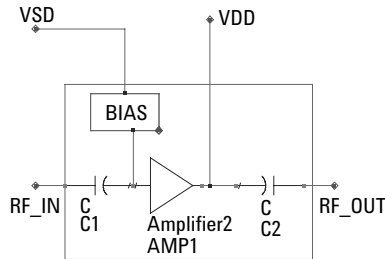

Surface Mount
2.0 x 2.0 x 1.1 mm³



Note:
Package marking provides Orientation and identification
"A" = Product Code
"Y" = Year
"WW" = Work Week

Pin Configuration

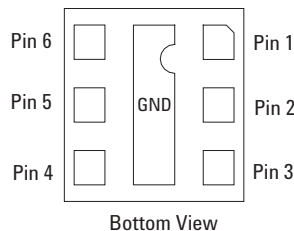

LNA I/O's :
1. NC 4. VSD
2. RF_IN 5. RF_OUT
3. NC 6. VDD
BOTTOM PADDLE : GND

Features

- Advanced GaAs E-pHEMT
- Low Noise: 0.8 dB typ
- High Gain : 14.3 dB typ
- Low component count
- High IIP3 and IP1dB
- Wide Supply Voltage: 1V to 3.6V
- Shutdown current : < 0.1uA
- CMOS compatible shutdown pin (VSD) current @ 2.85V : 90uA
- Adjustable bias current via one single external resistor/voltage
- Small Footprint: 2x2mm²
- Low Profile: 1.1mm typ
- Ext matching for non-GPS freq band operation

Specifications (25 deg): At 1.575GHz, 2.85V 8mA (Typ)

- Gain = 14.3 dB (Typ)
- NF = 0.8 dB (Typ)
- IIP3 = 4.7 dBm (Typ)
- IP1dB = 1.8 dBm (Typ)
- S11 = -11.8 dB (Typ)
- S22 = -12.4 dB (Typ)

Typical performance @ 1.0V supply

S21 = 12.3dB

NF = 1.0dB

Ids = 3.6mA

Note:
Measurements obtained using demoboard described in Figure 4.

Absolute Maximum Ratings [1]

Symbol	Parameter	Units	Absolute Maximum
VDS	Drain - Source Voltage[2]	V	3.6
IDS	Drain Current[2]	mA	15
Pdiss	Total Power Dissipation [3]	mW	54
Pin max.	RF Input Power	dBm	+10
TCH	Channel Temperature	°C	150
TSTG	Storage Temperature	°C	-65 to 150
θ_{ch_b}	Thermal Resistance [4]	°C/W	232

Notes:

1. Operation of this device above any one of these parameters may cause permanent damage.
2. Assuming DC quiescent conditions.
3. Board (package belly) temperature T_B is 25°C. Derate 4.32mW/°C for $T_B > 137$ °C.
4. Channel-to-board thermal resistance measured using 150°C Liquid Crystal Measurement method.

Product Consistency Distribution Charts [5,6]

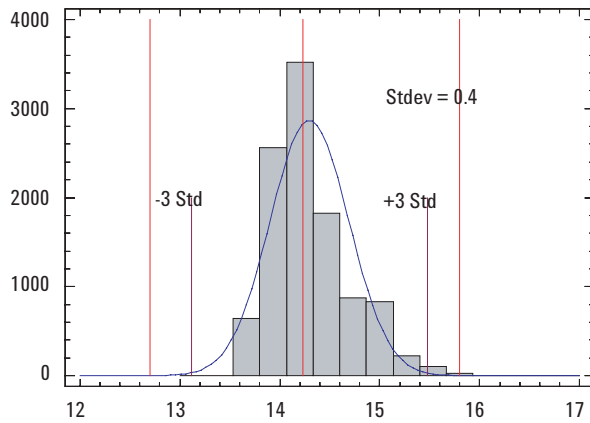

Figure 1. Gain @ 1.575GHz; LSL = 12.7dB, Nominal = 14.3dB, USL = 15.8dB

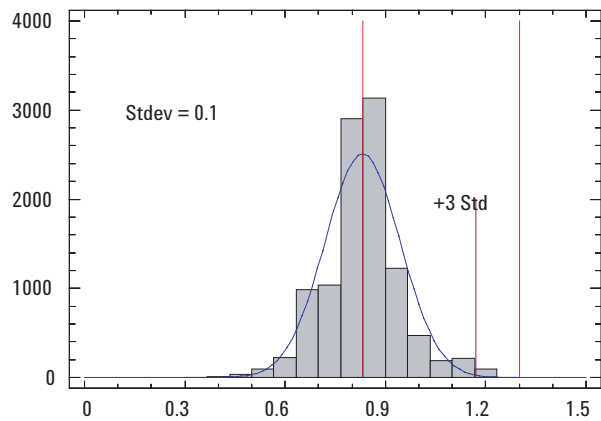

Figure 2. NF @ 1.575GHz; Nominal = 0.8dB, USL = 1.3dB

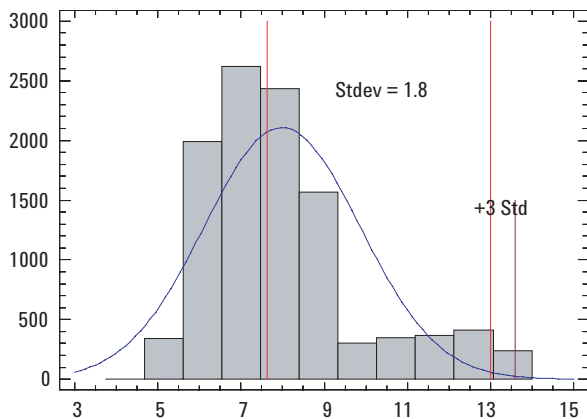

Figure 3. Ids @ 1.575GHz; Nominal = 8mA, USL = 13mA

Notes:

5. Distribution data sample size is 10K samples taken from 3 different wafers and 3 different lots. Future wafers allocated to this product may have nominal values anywhere between the upper and lower limits.
6. Measurements are made on production test board, which represents a trade-off between optimal Gain, NF, IIP3, IP1dB and VSWR. Circuit losses have been de-embedded from actual measurements.

Electrical Specifications

$T_A = 25\text{ }^\circ\text{C}$, DC bias for RF parameter is $V_{DD} = V_{SD} = +2.85\text{V}$ @ 8mA (unless otherwise specified)

$V_{DD} = V_{SD} = +2.85\text{V}$, $R_1 = 18\text{K Ohm}$, Freq=1.575GHz – Typical Performance

Table 1. Performance table at nominal operating conditions

Symbol	Parameter and Test Condition	Units	Min.	Typ	Max.
G	Gain	dB	12.7	14.3	15.8
NF	Noise Figure	dB	-	0.8	1.3
IP1dB	Input 1dB Compressed Power	dBm		1.8	
IIP3	Input 3rd Order Intercept Point (2-tone @ $F_c \pm 2.5\text{MHz}$)	dBm		4.7	
S11	Input Return Loss	dB		-11.8	
S22	Output Return Loss	dB		-12.4	
I _{ds}	Supply Current	mA		8	13
I _{sh}	Shutdown Current @ $V_{SD} = 0\text{V}$	uA		0.1	
V _{ds}	Supply Voltage	V		2.85	
IP1dB _{1710M}	Out of Band IP1dB (DCS 1710MHz) blocking	dBm		2.9	
IIP3 _{OUT}	Out of Band IIP3 (DCS 1775MHz & 1950MHz)	dBm		5.5	

$V_{DD} = +2\text{V}$, $V_{DD} = +1.5\text{V}$ & $V_{DD} = +1.0\text{V}$, Freq=1.575GHz – Typical Performance ($V_{SD} = V_{DD}$, $R_1 = 0\text{ Ohm}$)

Table 2 – Typical performance at low operation voltages with R1 (see Fig 5) set to 0 Ohm

Symbol	Parameter and Test Condition	Units	VDD=2V	VDD=1.5V	VDD=1.0V
G	Gain	dB	15	14.2	12.3
NF	Noise Figure	dB	0.8	0.9	1
IP1dB	Input 1dB Compressed Power	dBm	-1.4	-2.4	-3.8
IIP3	Input 3rd Order Intercept Point (2-tone @ $F_c \pm 2.5\text{MHz}$)	dBm	7.3	4.9	5.2
S11	Input Return Loss	dB	-13.8	-11.5	-8
S22	Output Return Loss	dB	-15.5	-14.5	-11.7
I _{ds}	Supply Current	mA	13	7.5	3.6
I _{sh}	Shutdown Current @ $V_{SD} = 0\text{V}$	uA	0.1	0.1	0.1
V _{ds}	Supply Voltage	V	2	1.5	1.0
IP1dB _{1710M}	Out of Band IP1dB (DCS 1710MHz) blocking	dBm	-0.3	-1.9	-2.9
IIP3 _{OUT}	Out of Band IIP3 (DCS 1775MHz & 1950MHz)	dBm	8.7	5.8	3

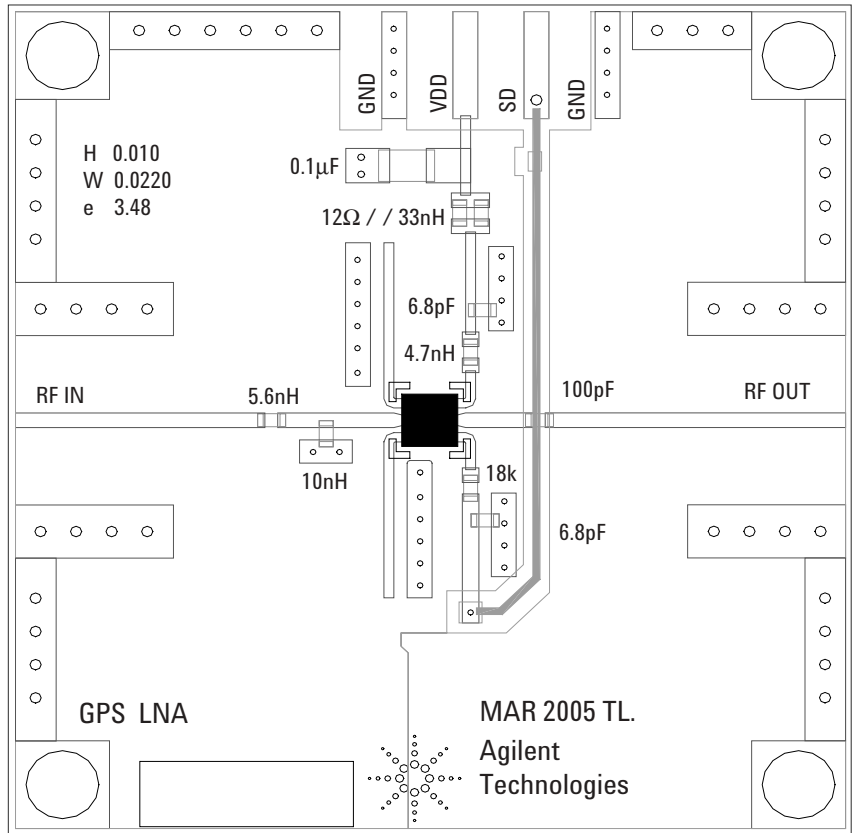

Figure 4. Demoboard and Application Circuit Components

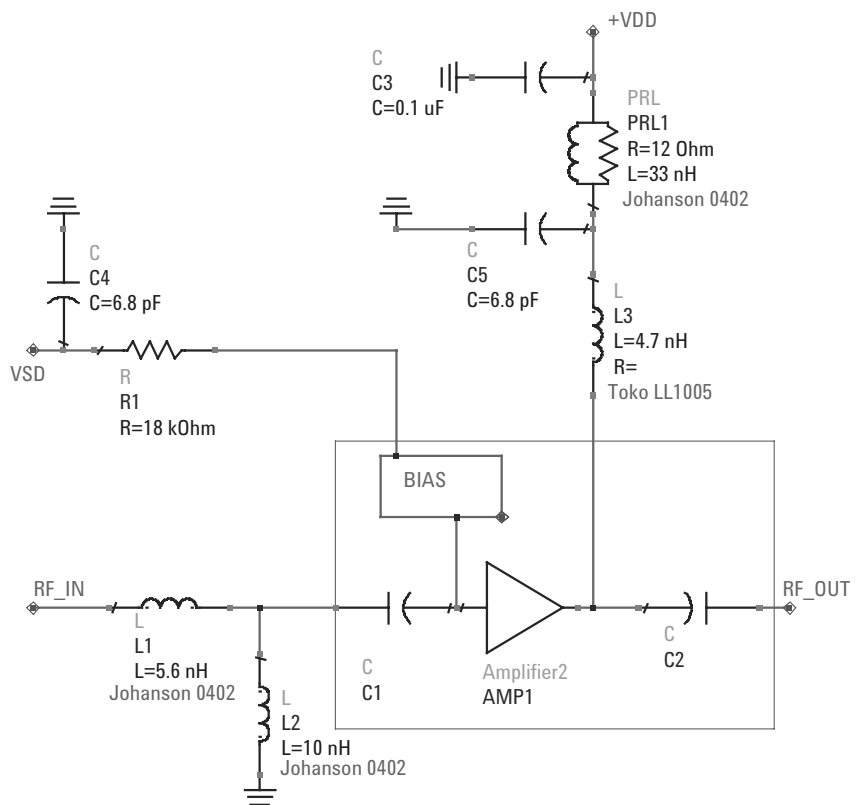

Figure 5. Demoboard schematic

Notes

- L1 and L2 form the input matching network. The LNA module has an integrated coupling and DC-blocking capacitors at the input and output. Best noise performance is obtained using high-Q wirewound inductors. This circuit demonstrates that low noise figures are obtainable with standard 0402 chip inductors. Replacing L1, L2 and L3 with high-Q wirewound inductors (eg. Cilcraft 0402CS series) will yield 0.1dB lower NF and 0.6dB higher Gain.
- L3 is an output matching inductor.
- C5 is a RF bypass capacitor.
- PRL1 is a network that isolates the measurement demoboard from external disturbances. C3 and C4 mitigate the effect of external noise pickup on the VSD and VDD lines. These components are not required in actual operation.
- Bias control is achieved by either varying the VSD voltage without R1 or fixing the VSD voltage to VDD and varying R1. Typical value for R1 is 18k Ohm for 8mA total current at VDD=+2.85V.
- Higher gain and IP3 performance can be obtained by increasing the supply current. This can be achieved by reducing the value for R1 to obtain desired current.
- For low voltage operation such as 1.5V or 1.0V, the R1 may be omitted and VSD connected directly to the supply pins.

ALM-1106 Typical Performance Curves, R1 = 18K Ohm (At 25°C unless specified otherwise)

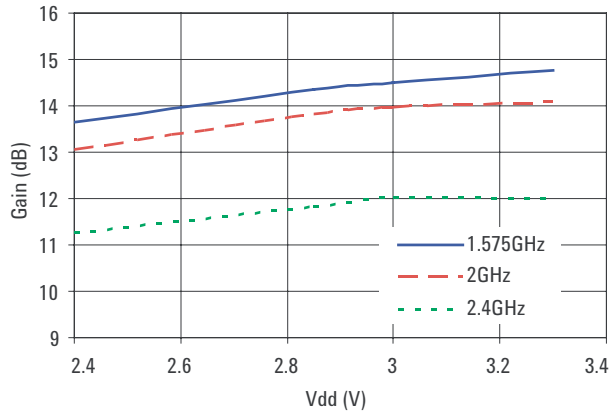

Figure 6. Gain vs Vdd vs Freq

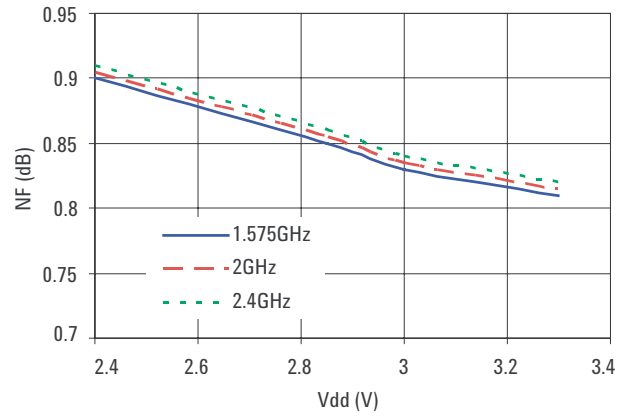

Figure 7. NF vs Vdd vs Freq

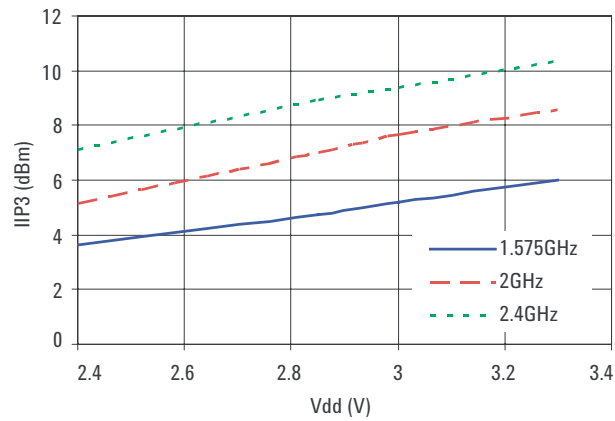

Figure 8. IIP3 vs Vdd vs Freq

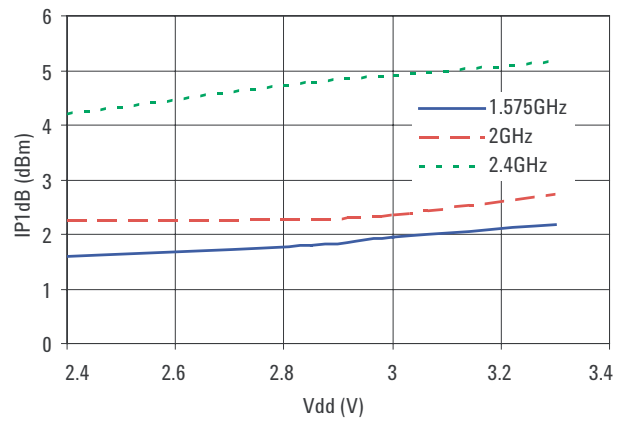

Figure 9. IP1dB vs Vdd vs Freq

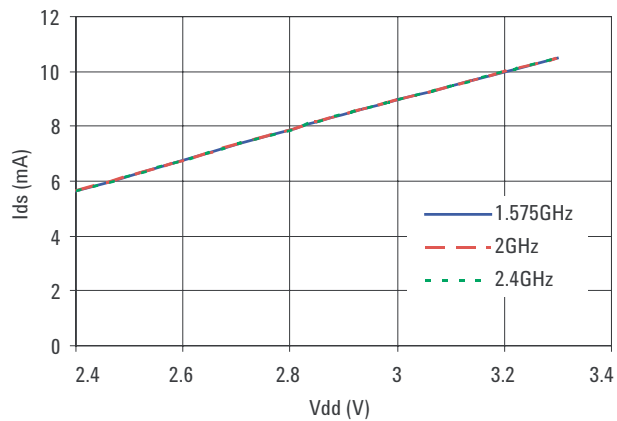

Figure 10. Ids vs Vdd vs Freq

ALM-1106 Typical Performance Curves, R1 = 18K Ohm (At 25°C unless specified otherwise)

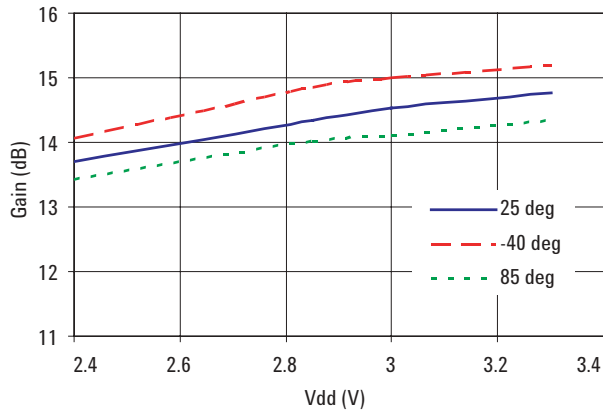

Figure 11. Gain vs Vdd vs Temp

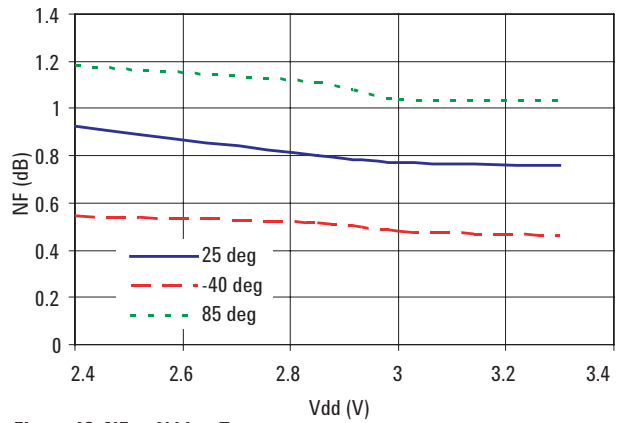

Figure 12. NF vs Vdd vs Temp

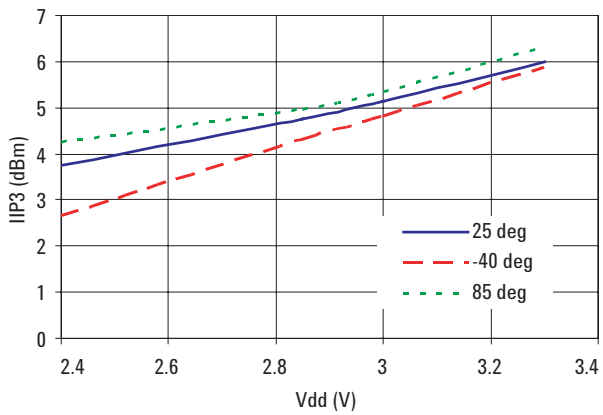

Figure 13. IIP3 vs Vdd vs Temp

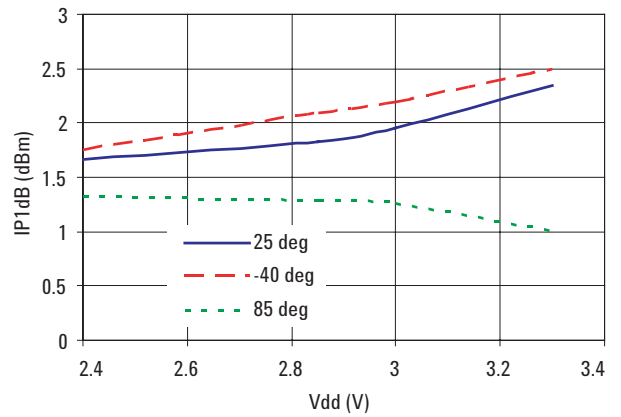

Figure 14. IP1dB vs Vdd vs Temp

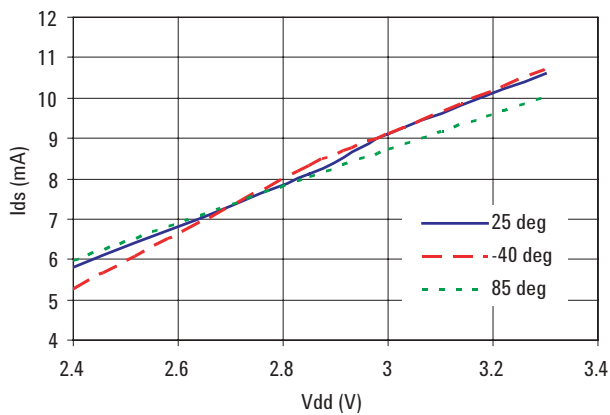

Figure 15. Ids vs Vdd vs Temp

ALM-1106 Typical Scattering Parameters at 25°C, V_{DD} = 2.85V, I_{DS} = 8 mA

Freq.	S11		S21		S12		S22			
	Mag.	Ang.	(dB)	Mag.	Ang.	(dB)	Mag.	Ang.	Mag.	Ang.
0.1	0.998	-4.7	15.01	5.633	176.7	-47.96	0.004	89.2	0.526	-5
0.5	0.946	-23.5	14.62	5.381	153.1	-34.42	0.019	78.6	0.503	-19
0.9	0.866	-40.4	13.72	4.854	134.1	-29.90	0.032	71.8	0.475	-31.9
1	0.843	-44.4	13.47	4.714	129.7	-29.37	0.034	70.5	0.468	-34.9
1.1	0.821	-48.2	13.20	4.573	125.5	-28.64	0.037	69.3	0.459	-37.9
1.2	0.8	-52	12.95	4.44	121.5	-27.96	0.04	68.5	0.451	-40.5
1.3	0.78	-55.8	12.69	4.31	117.6	-27.33	0.043	67.4	0.443	-43.2
1.4	0.757	-59.7	12.42	4.178	113.6	-26.94	0.045	66.5	0.435	-45.8
1.5	0.731	-63.4	12.13	4.039	109.7	-26.38	0.048	65.7	0.428	-48.2
1.6	0.705	-66.8	11.83	3.905	106.1	-26.02	0.05	64.8	0.421	-50.7
1.7	0.683	-69.7	11.55	3.78	102.9	-25.51	0.053	64.7	0.414	-52.8
1.8	0.663	-71.6	11.29	3.669	99.5	-25.19	0.055	63.9	0.408	-55.5
1.9	0.643	-73.4	10.99	3.544	96	-24.73	0.058	63.1	0.399	-58
2	0.623	-75.3	10.48	3.343	97	-24.58	0.059	66.3	0.398	-58.8
2.1	0.603	-77.2	10.25	3.253	93.5	-24.15	0.062	65.5	0.398	-59.6
2.2	0.583	-79	10.01	3.165	90.2	-23.74	0.065	64.6	0.397	-60.3
2.3	0.563	-80.9	9.77	3.079	87	-23.48	0.067	63.8	0.396	-61.1
2.4	0.543	-82.8	9.49	2.983	83.8	-23.10	0.07	63	0.396	-62.1
2.5	0.522	-85.3	9.23	2.895	81.1	-22.73	0.073	62.3	0.395	-62.7
3	0.434	-105.2	7.95	2.498	66.6	-21.21	0.087	56.9	0.345	-74.4
3.5	0.334	-119.5	6.47	2.105	57.3	-20.26	0.097	54	0.324	-86.8
4	0.302	-132.1	6.25	2.054	48.8	-18.42	0.12	53.7	0.271	-108
4.5	0.297	-141.8	5.50	1.883	33.1	-16.95	0.142	43.4	0.265	-113.3
5	0.274	-157.1	4.44	1.667	23.9	-15.97	0.159	38	0.259	-118.6
5.5	0.254	-170.1	3.63	1.519	16.1	-15.04	0.177	33.7	0.26	-133.2
6	0.211	178.7	2.82	1.383	6.3	-14.11	0.197	25.3	0.249	-142.7
6.5	0.204	165.4	1.89	1.243	-0.7	-13.64	0.208	16.7	0.263	-154.7
7	0.189	137.1	1.56	1.197	-5.4	-13.27	0.217	12.7	0.306	-171.3
7.5	0.193	117.3	1.03	1.126	-14.4	-12.88	0.227	9.5	0.31	179.8
8	0.206	90.6	0.87	1.105	-22.2	-12.40	0.24	4.7	0.314	170.8

ALM-1106 Typical Noise Parameters, V_{DD} = 2.85V, I_{DS} = 8mA

Freq (GHz)	F _{min} (dB)	Γ _{opt} Mag.	Γ _{opt} Ang.	R _n /50	NF @ 50dB
0.5	0.53	0.64	13.8	0.41	1.46
0.9	0.65	0.69	32.2	0.28	1.07
1.5	0.8	0.71	47.4	0.24	1.22
1.7	0.82	0.69	58.1	0.22	1.14
2	0.91	0.68	59.5	0.23	1.1
2.4	0.93	0.64	71.3	0.27	1.72
3	1.21	0.52	99.2	0.16	1.45
3.5	1.33	0.44	135.8	0.12	1.6
4	1.69	0.35	161.3	0.08	1.27
4.5	1.73	0.31	171.3	0.06	1.47
5	1.82	0.32	-179.6	0.06	1.65
5.5	1.98	0.34	-171.2	0.08	2.16
5.8	2.37	0.43	-174.8	0.14	2.88

Package Dimensions

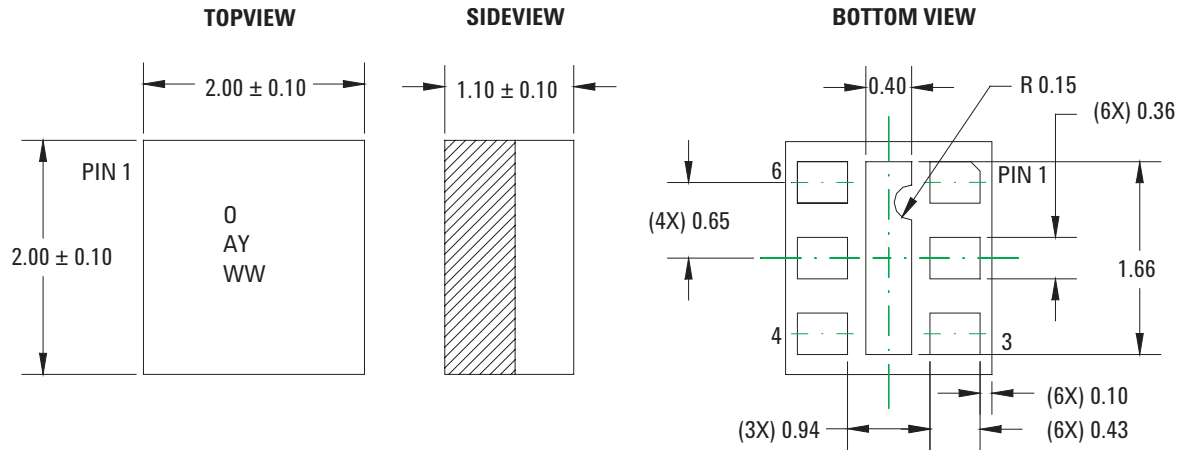

Device Orientation

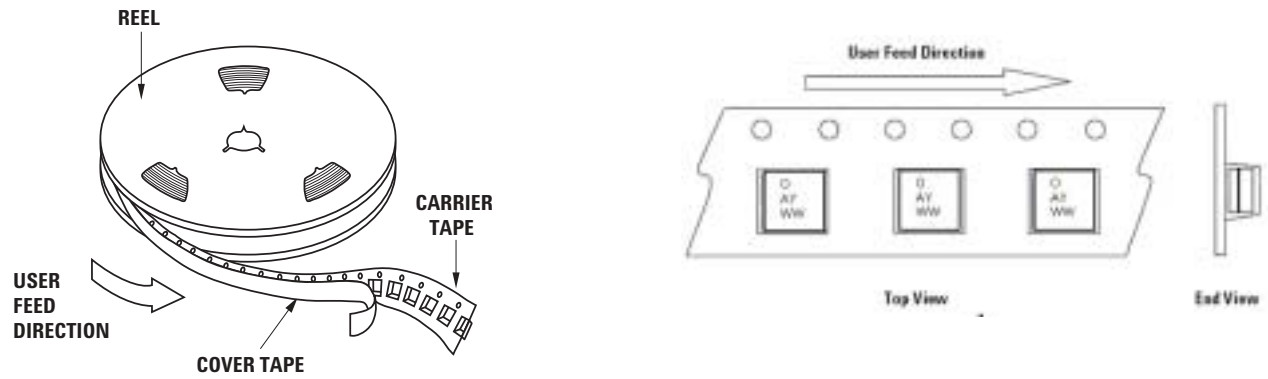

Tape Dimensions

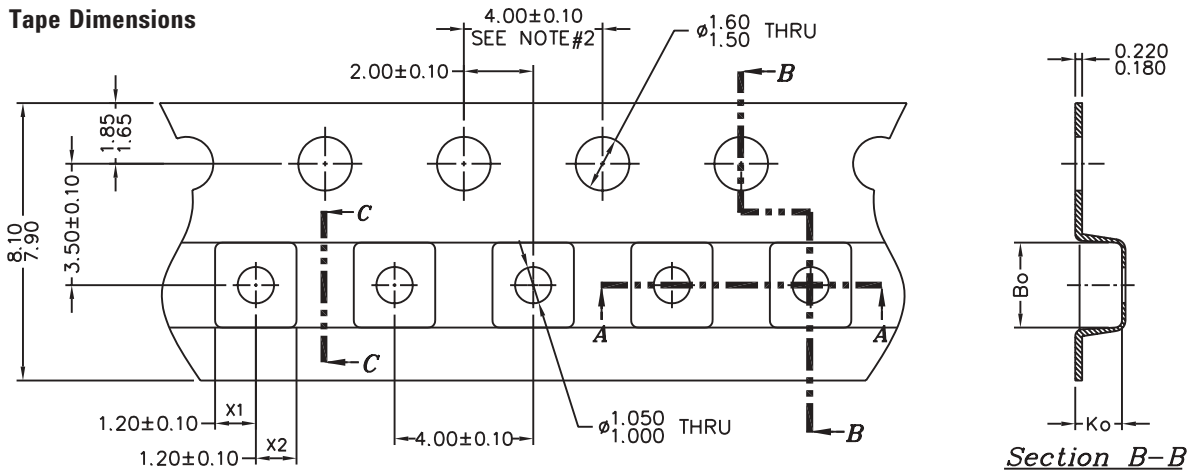

Notes:

1. Measured from centerline of sprocket hole to centerline of pocket
 2. Cumulative tolerance of 10 sprocket holes is ± 0.20
- All dimensions in millimeters unless otherwise stated.

Reel Dimensions

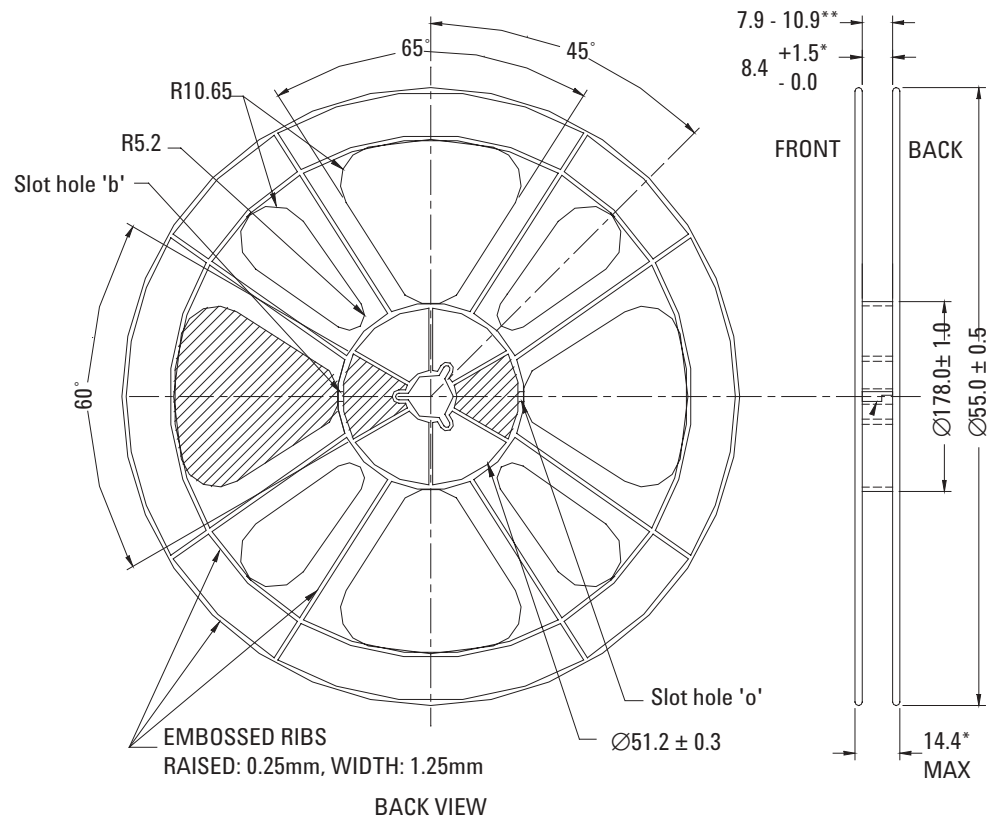
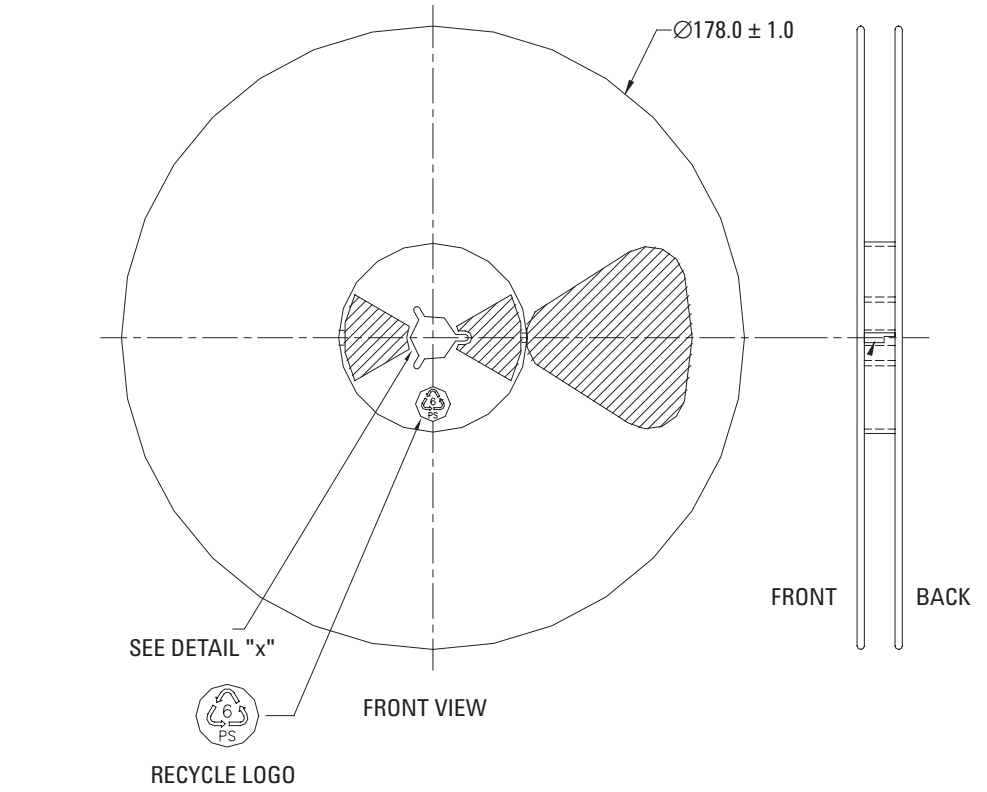

Part Number Ordering Information

Part Number	No. of Devices	Container
ALM-1106-TR1	3000	7" Reel
ALM-1106-TR2	10000	13" Reel
ALM-1106-BLK	100	antistatic bag

For product information and a complete list of distributors, please go to our web site: www.avagotech.com

Avago, Avago Technologies, and the A logo are trademarks of Avago Technologies, Pte. in the United States and other countries.
Data subject to change. Copyright © 2006 Avago Technologies Pte. All rights reserved. Obsoletes 5989-3889EN
AV01-0028EN - February 22, 2006

