



# BIPOLAR ANALOG INTEGRATED CIRCUIT

## $\mu$ PC3242TB

### 3.3 V, SILICON GERMANIUM MMIC WIDE BAND AMPLIFIER

#### DESCRIPTION

The  $\mu$ PC3242TB is a silicon germanium monolithic integrated circuit designed as IF amplifier for DBS LNB. This device exhibits low noise figure and high power gain characteristics. This IC is manufactured using our UHSK3 (Ultra High Speed Process) silicon germanium bipolar process.

#### FEATURES

- Low current :  $I_{CC} = 4.3$  mA TYP.
- Power gain :  $G_P = 22$  dB TYP. @  $f = 1.0$  GHz  
:  $G_P = 22$  dB TYP. @  $f = 2.2$  GHz
- Gain flatness :  $\Delta G_P = 0.4$  dB TYP. @  $f = 1.0$  to  $2.2$  GHz
- Noise figure :  $NF = 4.0$  dB TYP. @  $f = 1.0$  GHz  
:  $NF = 4.0$  dB TYP. @  $f = 2.2$  GHz
- High linearity :  $P_{O(1\text{ dB})} = -7.5$  dBm TYP. @  $f = 1.0$  GHz  
:  $P_{O(1\text{ dB})} = -9.5$  dBm TYP. @  $f = 2.2$  GHz
- Supply voltage :  $V_{CC} = +3.0$  to  $+3.6$  V
- Port impedance : input/output  $50 \Omega$

#### APPLICATIONS

- IF amplifiers in DBS LNB, other L-band amplifiers, etc.

#### ORDERING INFORMATION

Part Number	Order Number	Package	Marking	Supplying Form
$\mu$ PC3242TB-E3	$\mu$ PC3242TB-E3-A	6-pin super minimold (Pb-Free)	C3Z	<ul style="list-style-type: none"><li>• Embossed tape 8 mm wide</li><li>• Pin 1, 2, 3 face the perforation side of the tape</li><li>• Qty 3 kpcs/reel</li></ul>

**Remark** To order evaluation samples, please contact your nearby sales office.  
Part number for sample order:  $\mu$ PC3242TB

**Caution** Observe precautions when handling because these devices are sensitive to electrostatic discharge.

The information in this document is subject to change without notice. Before using this document, please confirm that this is the latest version.

**PIN CONNECTIONS AND INTERNAL BLOCK DIAGRAM**

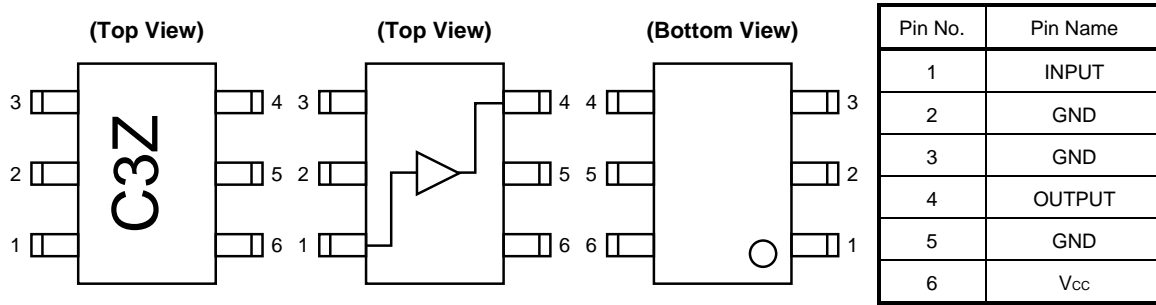

**PRODUCT LINE-UP OF 5 V or 3.3 V-BIAS SILICON MMIC WIDE BAND AMPLIFIER**

(T<sub>A</sub> = +25°C, V<sub>CC</sub> = +5.0 V or +3.3 V, Z<sub>s</sub> = Z<sub>L</sub> = 50 Ω)

Part No.	V <sub>CC</sub> (V)	I <sub>CC</sub> (mA)	G <sub>P</sub> (dB)	NF (dB)	P <sub>O(sat)</sub> (dBm)	P <sub>O(1 dB)</sub> (dBm)	Package	Marking
μPC2711TB	+5.0	12.0	13.0 (1.0 GHz)	5.0 (1.0 GHz)	+1.0 (1.0 GHz)	-	6-pin super minimold	C1G
μPC2712TB		12.0	20.0 (1.0 GHz)	4.5 (1.0 GHz)	+3.0 (1.0 GHz)	-		C1H
μPC3215TB		14.0	20.5 (1.5 GHz)	2.3 (1.5 GHz)	+3.5 (1.5 GHz)	+1.5 (1.5 GHz)		C3H
μPC3224TB		9.0	21.5 (1.0 GHz)	4.3 (1.0 GHz)	+4.0 (1.0 GHz)	-3.5 (1.0 GHz)		C3K
				4.3 (2.2 GHz)	+1.5 (2.2 GHz)	-5.5 (2.2 GHz)		
μPC3227TB	4.8	22.0 (1.0 GHz)	4.7 (1.0 GHz)	-1.0 (1.0 GHz)	-6.5 (1.0 GHz)	C3P		
			4.6 (2.2 GHz)	-3.5 (2.2 GHz)	-8.0 (2.2 GHz)			
μPC3240TB	+3.3	13.0	25.0 (1.0 GHz)	4.3 (1.0 GHz)	-	+1.0 (1.0 GHz)	C3W	
			24.5 (2.2 GHz)	4.5 (2.2 GHz)	-	-4.0 (2.2 GHz)		
μPC3242TB		4.3	22.0 (1.0 GHz)	4.0 (1.0 GHz)	-0.5 (1.0 GHz)	-7.5 (1.0 GHz)		C3Z
				4.0 (2.2 GHz)	-4.0 (2.2 GHz)	-9.5 (2.2 GHz)		

**Remark** Typical performance. Please refer to **ELECTRICAL CHARACTERISTICS** in detail.

**ABSOLUTE MAXIMUM RATINGS**

Parameter	Symbol	Conditions	Ratings	Unit
Supply Voltage	V <sub>CC</sub>	T <sub>A</sub> = +25°C	4.0	V
Total Circuit Current	I <sub>CC</sub>	T <sub>A</sub> = +25°C	10	mA
Power Dissipation	P <sub>D</sub>	T <sub>A</sub> = +85°C <b>Note</b>	270	mW
Operating Ambient Temperature	T <sub>A</sub>		-40 to +85	°C
Storage Temperature	T <sub>stg</sub>		-55 to +150	°C
Input Power	P <sub>in</sub>	T <sub>A</sub> = +25°C	-10	dBm

**Note** Mounted on double-sided copper-clad 50 × 50 × 1.6 mm epoxy glass PWB

**RECOMMENDED OPERATING RANGE**

Parameter	Symbol	Conditions	MIN.	TYP.	MAX.	Unit
Supply Voltage	V <sub>CC</sub>		+3.0	+3.3	+3.6	V
Operating Ambient Temperature	T <sub>A</sub>		-40	+25	+85	°C

**ELECTRICAL CHARACTERISTICS** ( $T_A = +25^\circ\text{C}$ ,  $V_{CC} = +3.3\text{ V}$ ,  $Z_s = Z_L = 50\ \Omega$ , unless otherwise specified)

Parameter	Symbol	Test Conditions	MIN.	TYP.	MAX.	Unit
Circuit Current	$I_{CC}$	No input signal	3.6	4.3	5.0	mA
Power Gain 1	$G_{P1}$	$f = 0.25\text{ GHz}$ , $P_{in} = -40\text{ dBm}$	19	22	25	dB
Power Gain 2	$G_{P2}$	$f = 1.0\text{ GHz}$ , $P_{in} = -40\text{ dBm}$	19	22	25	
Power Gain 3	$G_{P3}$	$f = 1.8\text{ GHz}$ , $P_{in} = -40\text{ dBm}$	19	22	25	
Power Gain 4	$G_{P4}$	$f = 2.2\text{ GHz}$ , $P_{in} = -40\text{ dBm}$	19	22	25	
Gain 1 dB Compression Output Power 1	$P_{O(1\text{ dB})1}$	$f = 1.0\text{ GHz}$	-10	-7.5	-	dBm
Gain 1 dB Compression Output Power 2	$P_{O(1\text{ dB})2}$	$f = 2.2\text{ GHz}$	-12.5	-9.5	-	
Noise Figure 1	NF1	$f = 1.0\text{ GHz}$	-	4.0	4.8	dB
Noise Figure 2	NF2	$f = 2.2\text{ GHz}$	-	4.0	4.8	
Isolation 1	ISL1	$f = 1.0\text{ GHz}$ , $P_{in} = -40\text{ dBm}$	31	36.5	-	dB
Isolation 2	ISL2	$f = 2.2\text{ GHz}$ , $P_{in} = -40\text{ dBm}$	34	40.5	-	
Input Return Loss 1	$RL_{in1}$	$f = 1.0\text{ GHz}$ , $P_{in} = -40\text{ dBm}$	10	14	-	dB
Input Return Loss 2	$RL_{in2}$	$f = 2.2\text{ GHz}$ , $P_{in} = -40\text{ dBm}$	6	8.5	-	
Output Return Loss 1	$RL_{out1}$	$f = 1.0\text{ GHz}$ , $P_{in} = -40\text{ dBm}$	8	11	-	dB
Output Return Loss 2	$RL_{out2}$	$f = 2.2\text{ GHz}$ , $P_{in} = -40\text{ dBm}$	8	11	-	

**STANDARD CHARACTERISTICS FOR REFERENCE**

( $T_A = +25^\circ\text{C}$ ,  $V_{CC} = +3.3\text{ V}$ ,  $Z_s = Z_L = 50\ \Omega$ , unless otherwise specified)

Parameter	Symbol	Test Conditions	Reference Value	Unit
Power Gain 5	$G_{P5}$	$f = 2.6\text{ GHz}$ , $P_{in} = -40\text{ dBm}$	20.5	dB
Power Gain 6	$G_{P6}$	$f = 3.0\text{ GHz}$ , $P_{in} = -40\text{ dBm}$	19	
Gain Flatness	$\Delta G_P$	$f = 1.0\text{ to }2.2\text{ GHz}$ , $P_{in} = -40\text{ dBm}$	0.4	dB
Saturated Output Power 1	$P_{O(sat)1}$	$f = 1.0\text{ GHz}$ , $P_{in} = -15\text{ dBm}$	-0.5	dBm
Saturated Output Power 2	$P_{O(sat)2}$	$f = 2.2\text{ GHz}$ , $P_{in} = -15\text{ dBm}$	-4.0	
K factor 1	K1	$f = 1.0\text{ GHz}$ , $P_{in} = -40\text{ dBm}$	2.5	-
K factor 2	K2	$f = 2.2\text{ GHz}$ , $P_{in} = -40\text{ dBm}$	3.4	-
Output 3rd Order Intercept Point 1	OIP <sub>3</sub> 1	$f_1 = 1\ 000\text{ MHz}$ , $f_2 = 1\ 001\text{ MHz}$	1.5	dBm
Output 3rd Order Intercept Point 2	OIP <sub>3</sub> 2	$f_1 = 2\ 200\text{ MHz}$ , $f_2 = 2\ 201\text{ MHz}$	-0.5	
Input 3rd Order Intercept Point 1	IIP <sub>3</sub> 1	$f_1 = 1\ 000\text{ MHz}$ , $f_2 = 1\ 001\text{ MHz}$	-20	dBm
Input 3rd Order Intercept Point 2	IIP <sub>3</sub> 2	$f_1 = 2\ 200\text{ MHz}$ , $f_2 = 2\ 201\text{ MHz}$	-22	
2nd Order Intermodulation Distortion	IM <sub>2</sub>	$f_1 = 1\ 000\text{ MHz}$ , $f_2 = 1\ 001\text{ MHz}$ , $P_{in} = -40\text{ dBm/ tone}$	22	dBc
2nd Harmonics	2f <sub>0</sub>	$f_0 = 1.0\text{ GHz}$ , $P_{in} = -40\text{ dBm}$	28.5	dBc

## TEST CIRCUIT

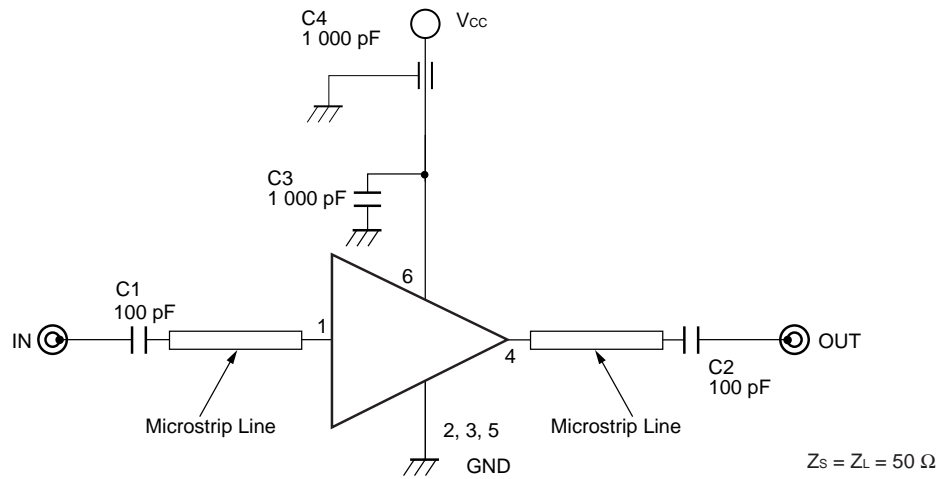

The application circuits and their parameters are for reference only and are not intended for use in actual design-ins.

#### COMPONENTS OF TEST CIRCUIT FOR MEASURING ELECTRICAL CHARACTERISTICS

	Type	Value
C1, C2	Chip Capacitor	100 pF
C3	Chip Capacitor	1 000 pF
C4	Feed-through Capacitor	1 000 pF

#### CAPACITORS FOR THE V<sub>cc</sub>, INPUT AND OUTPUT PINS

Capacitors of 1 000 pF are recommendable as the bypass capacitor for the V<sub>cc</sub> pin and the coupling capacitors for the input and output pins.

The bypass capacitor connected to the V<sub>cc</sub> pin is used to minimize ground impedance of V<sub>cc</sub> pin. So, stable bias can be supplied against V<sub>cc</sub> fluctuation.

The coupling capacitors, connected to the input and output pins, are used to cut the DC and minimize RF serial impedance. Their capacitances are therefore selected as lower impedance against a 50 Ω load. The capacitors thus perform as high pass filters, suppressing low frequencies to DC.

ILLUSTRATION OF THE TEST CIRCUIT ASSEMBLED ON EVALUATION BOARD

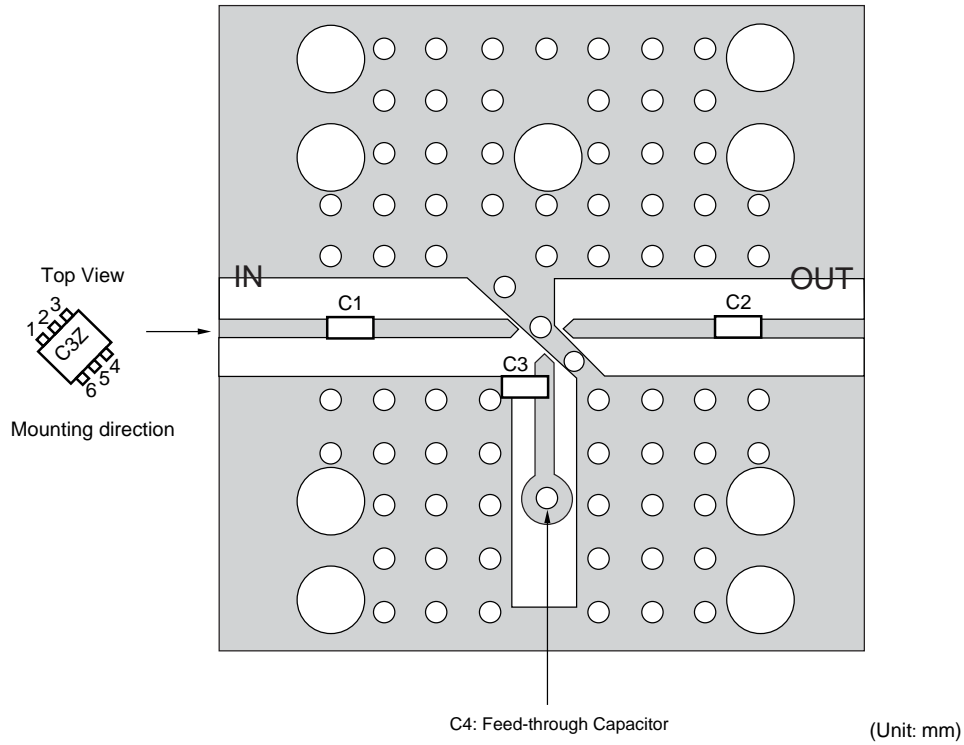

Notes

1. 30 × 30 × 0.4 mm double sided 35 μm copper clad polyimide board.
2. Back side: GND pattern
3. Au plated on pattern
4. o: Through holes

COMPONENT LIST

	Type	Value	Size
C1, C2	Chip Capacitor	100 pF	1608
C3	Chip Capacitor	1 000 pF	1608
C4	Feed-through Capacitor	1 000 pF	-

**TYPICAL CHARACTERISTICS ( $T_A = +25^\circ\text{C}$ ,  $V_{CC} = +3.3\text{ V}$ ,  $Z_s = Z_L = 50\ \Omega$ , unless otherwise specified)**

**CIRCUIT CURRENT vs. SUPPLY VOLTAGE**

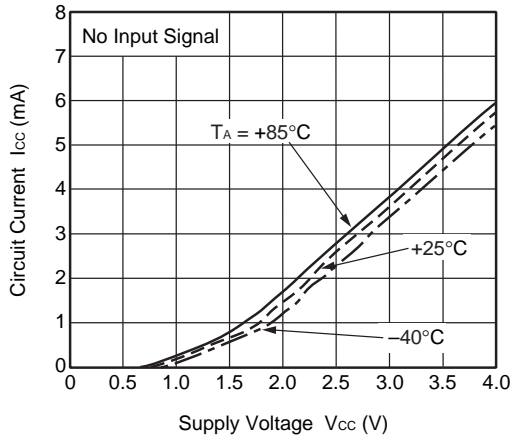

**CIRCUIT CURRENT vs. OPERATING AMBIENT TEMPERATURE**

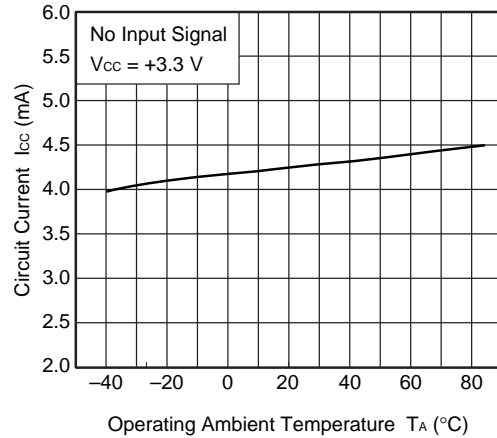

**POWER GAIN vs. FREQUENCY**

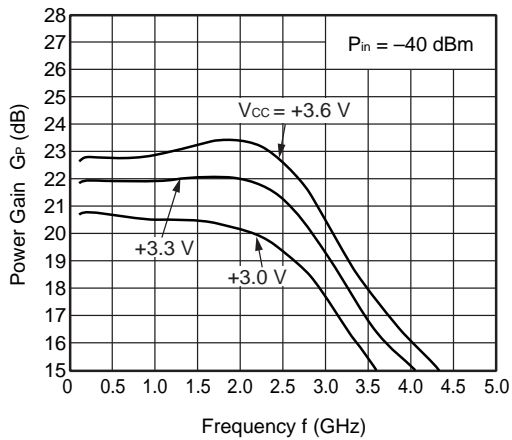

**INPUT RETURN LOSS vs. FREQUENCY**

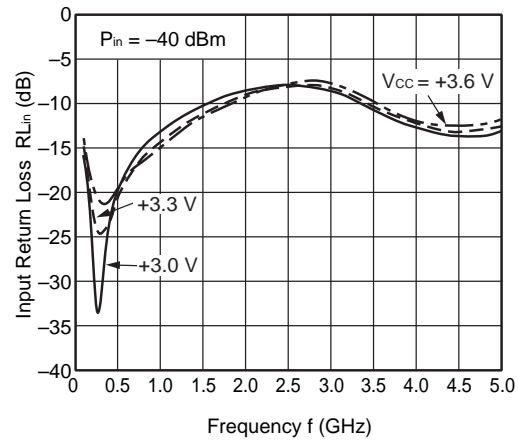

**ISOLATION vs. FREQUENCY**

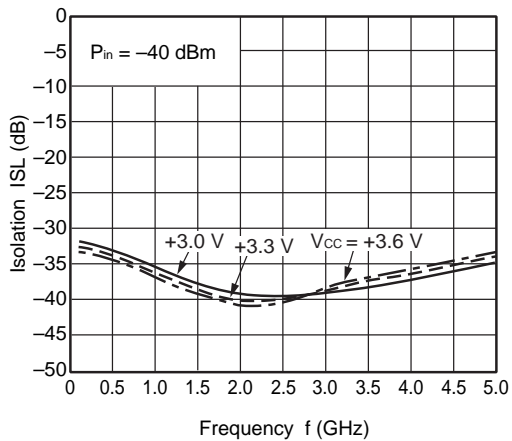

**OUTPUT RETURN LOSS vs. FREQUENCY**

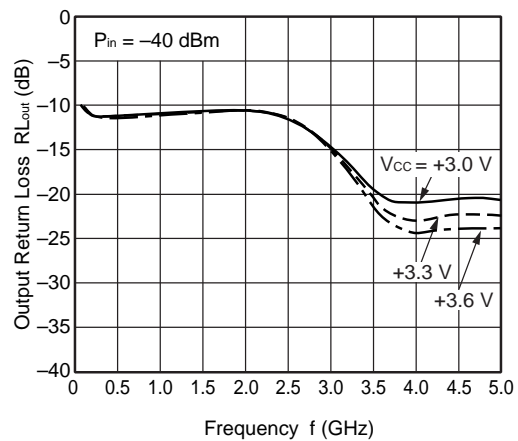

**Remark** The graphs indicate nominal characteristics.

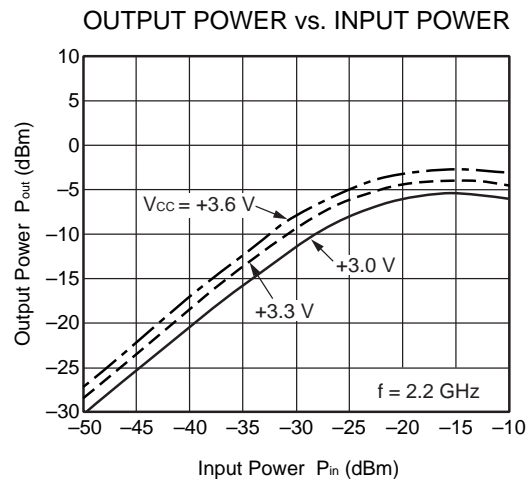
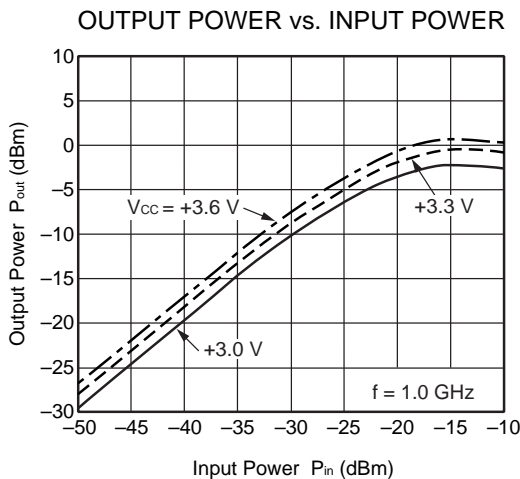
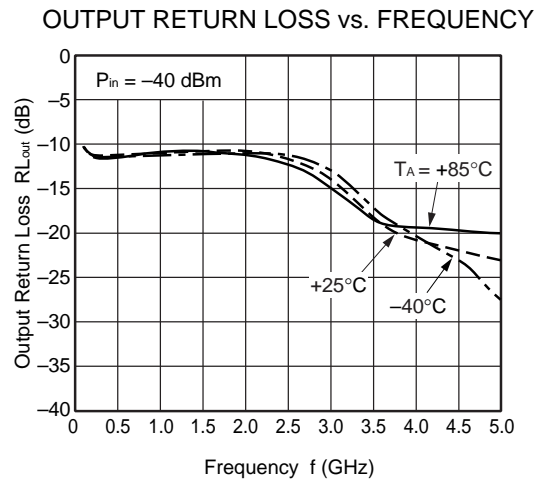
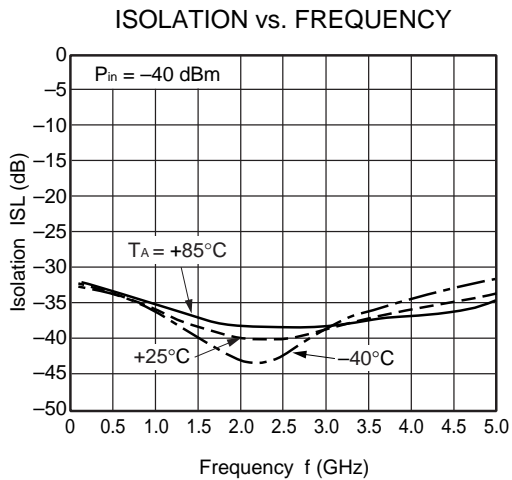
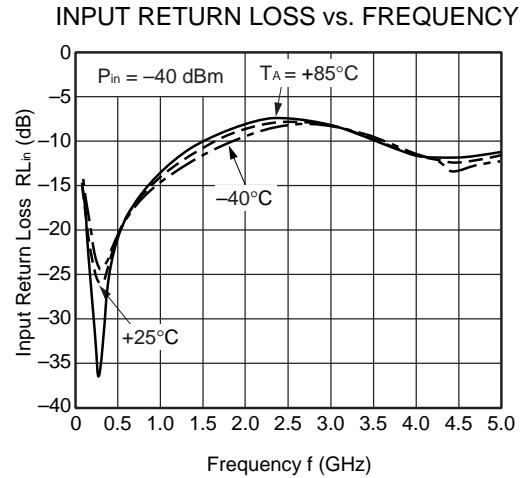
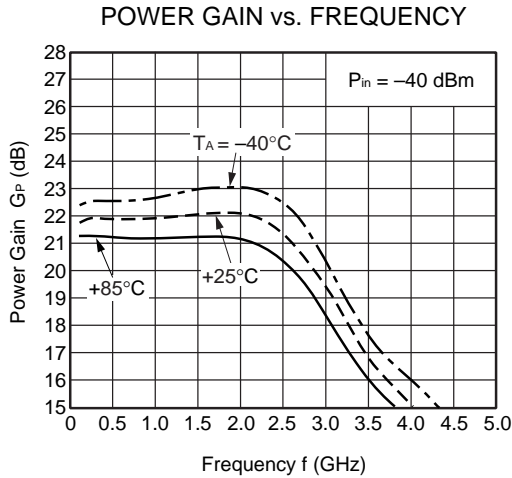

**Remark** The graphs indicate nominal characteristics.



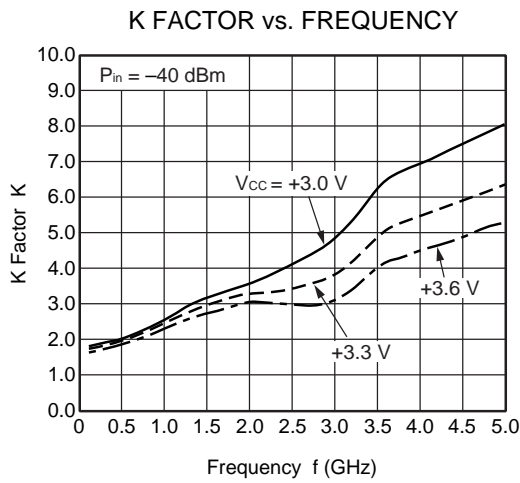
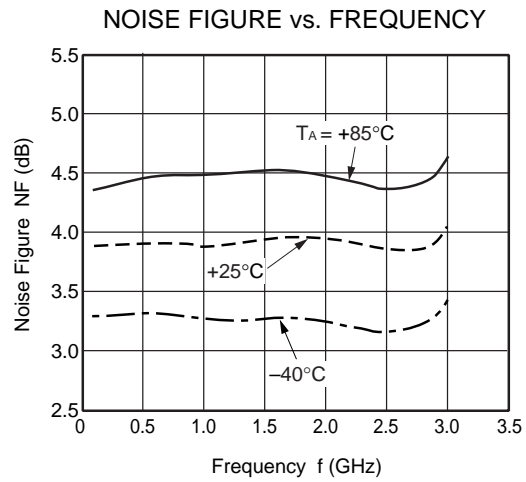
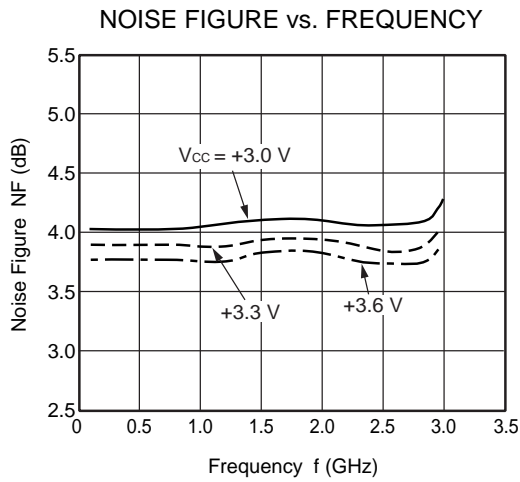
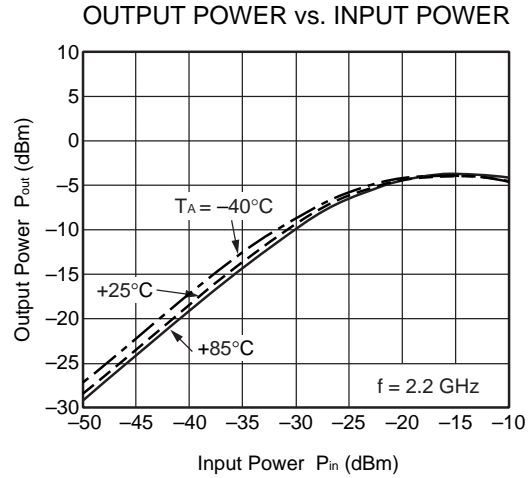
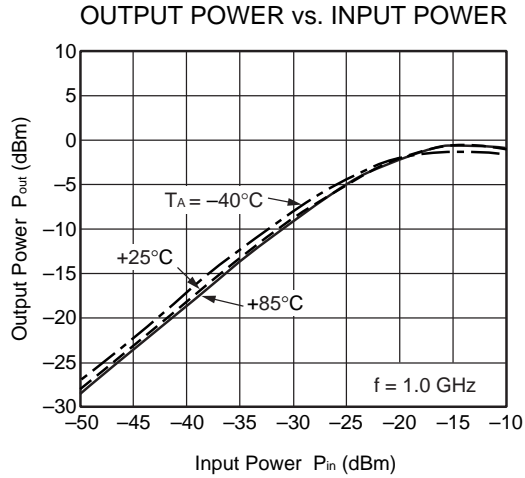

**Remark** The graphs indicate nominal characteristics.

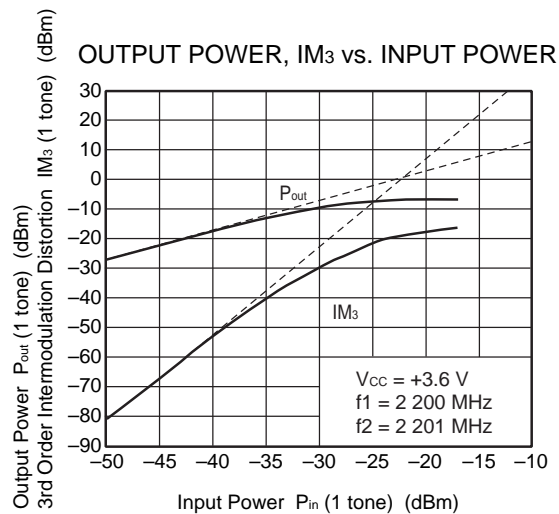
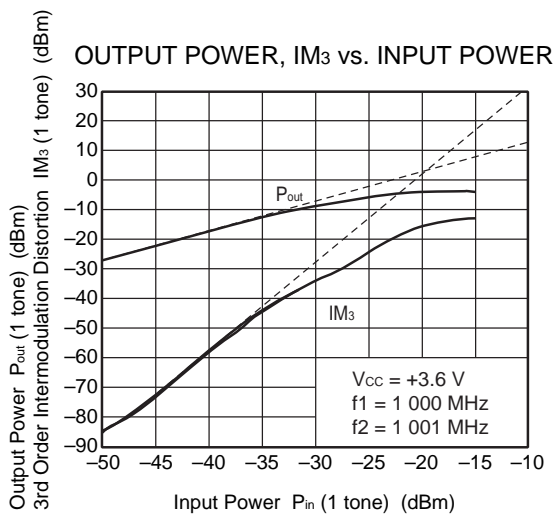
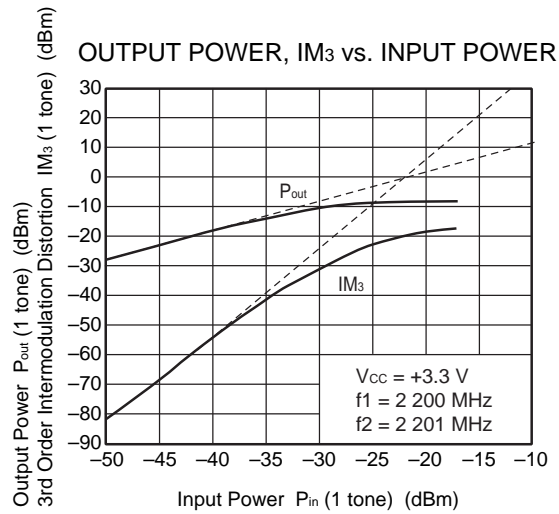
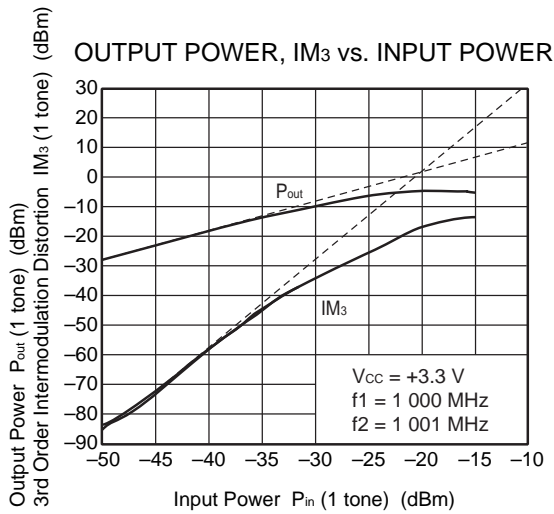
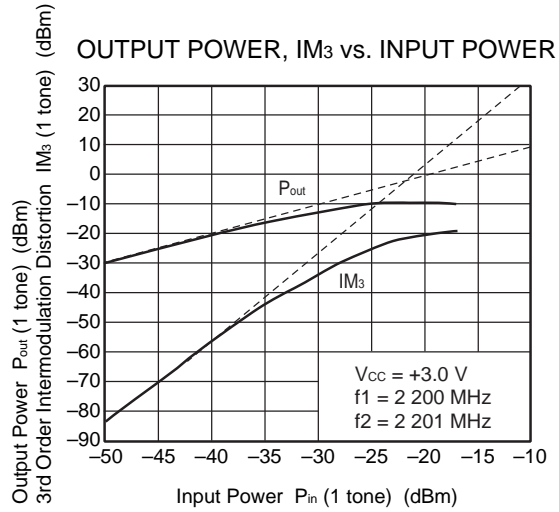
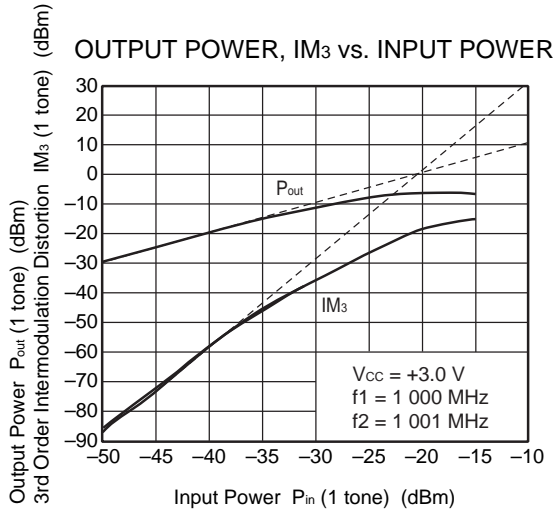

**Remark** The graphs indicate nominal characteristics.

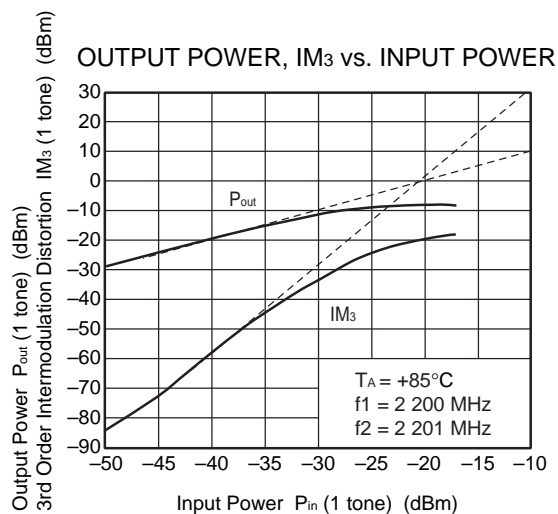
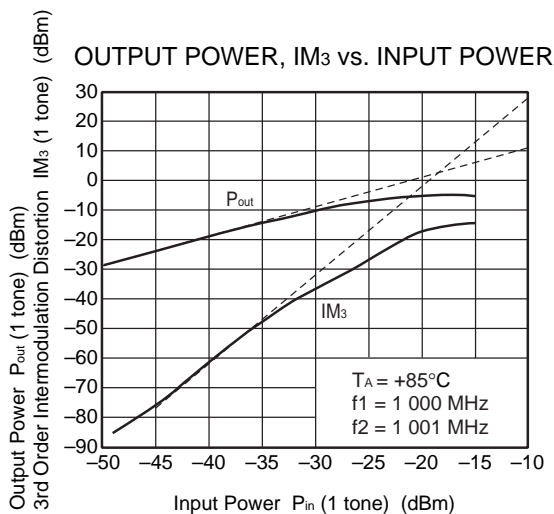
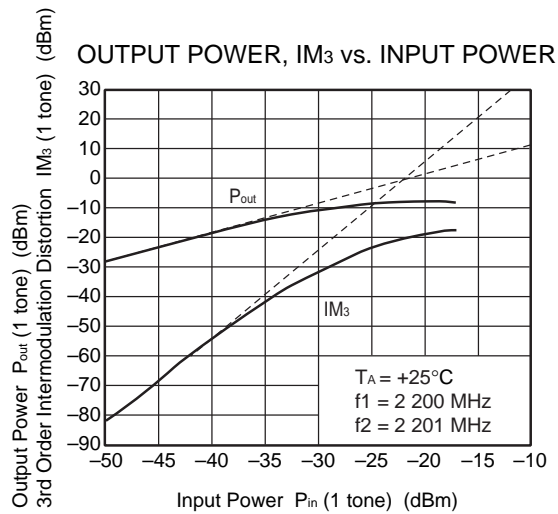
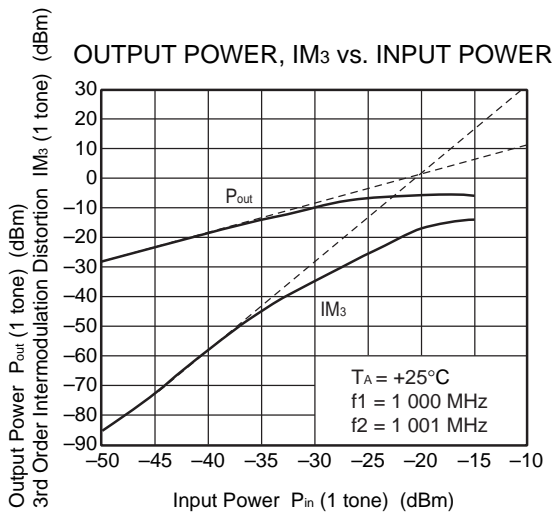
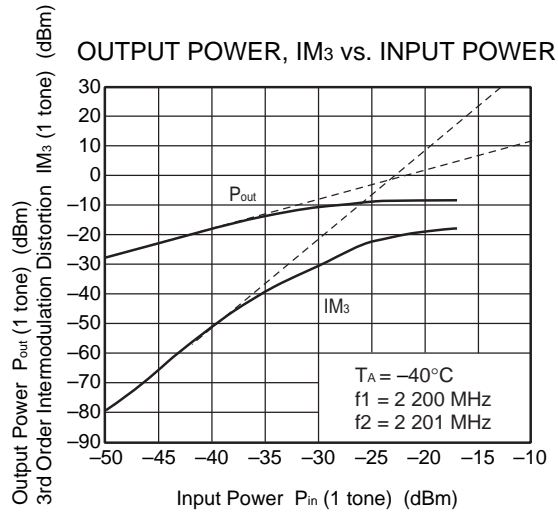
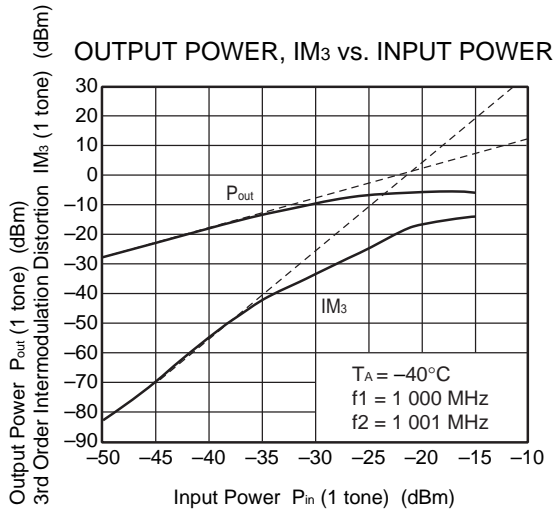

**Remark** The graphs indicate nominal characteristics.

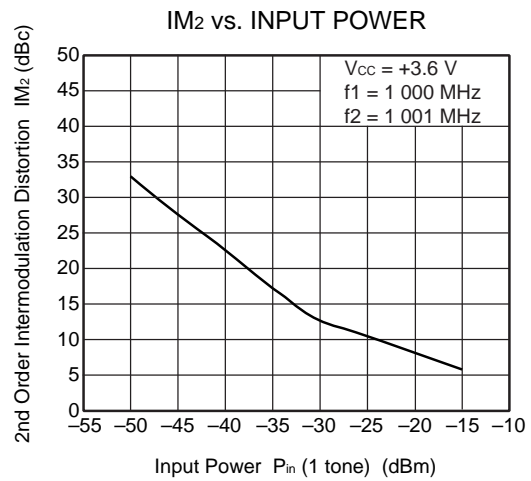
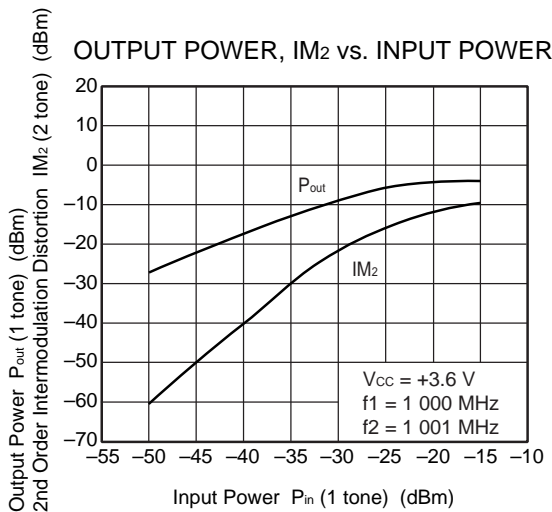
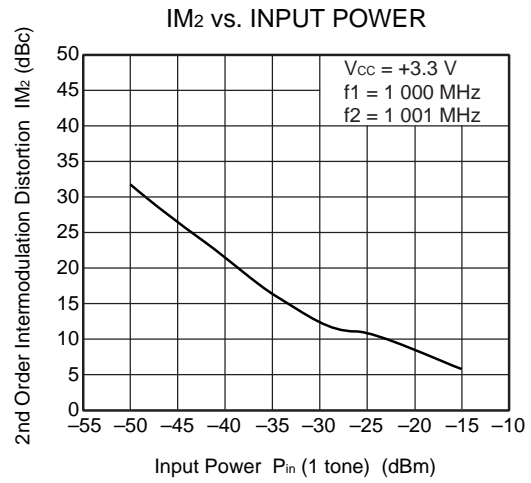
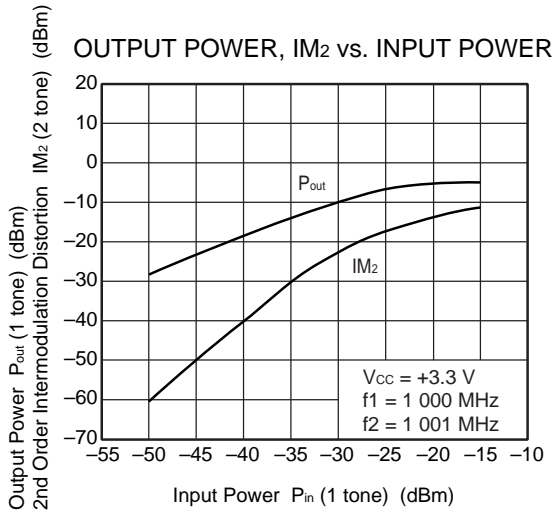
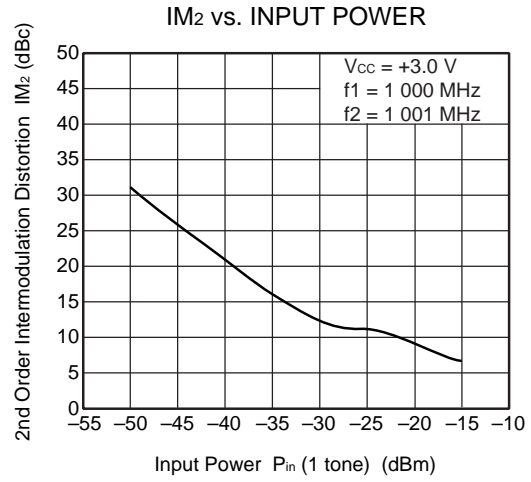
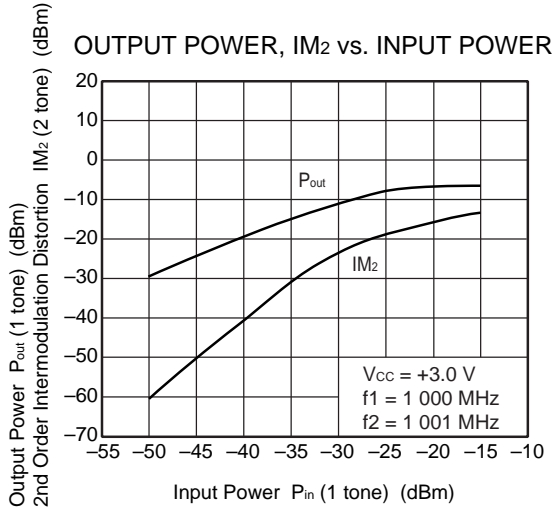

**Remark** The graphs indicate nominal characteristics.

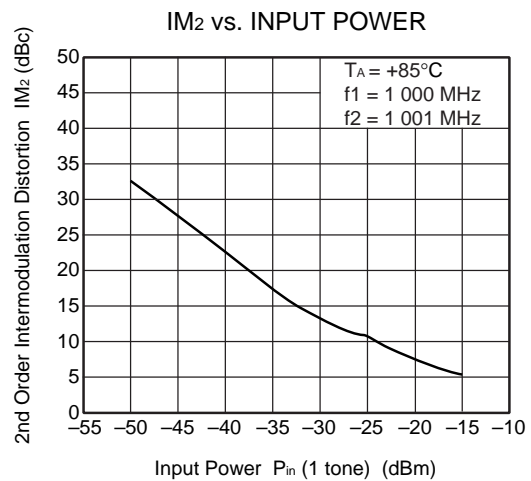
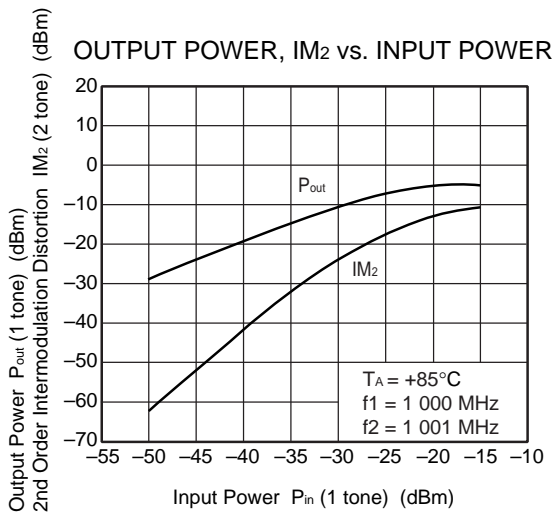
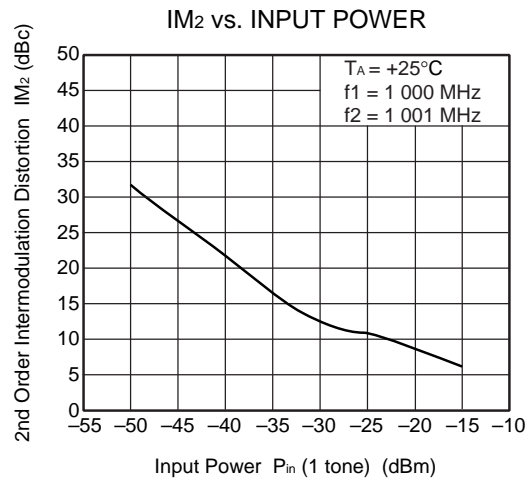
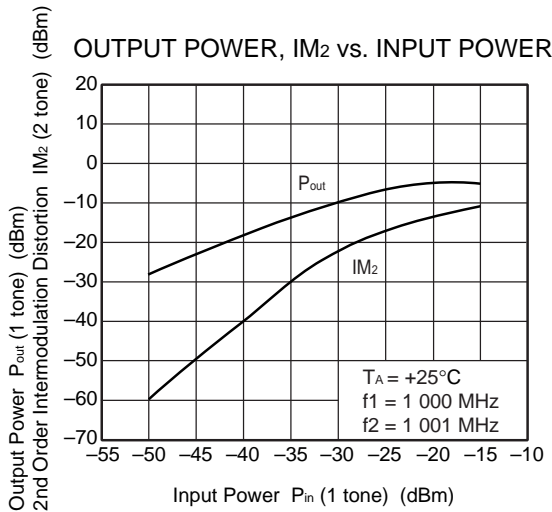
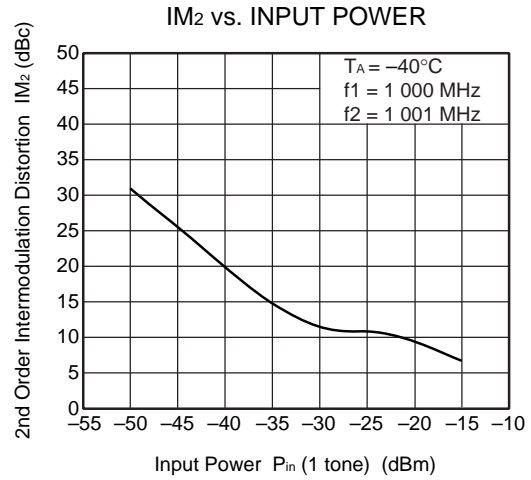
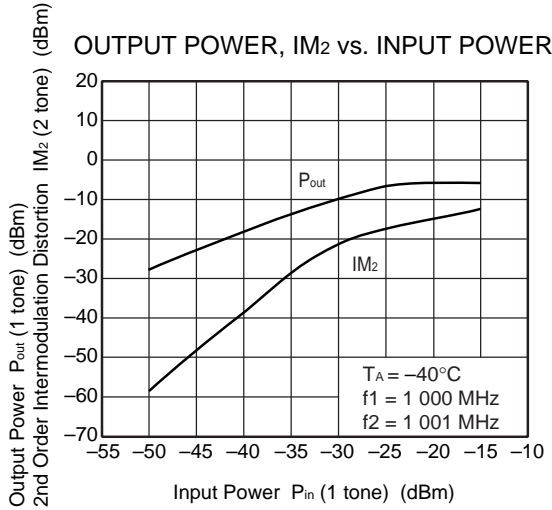

**Remark** The graphs indicate nominal characteristics.

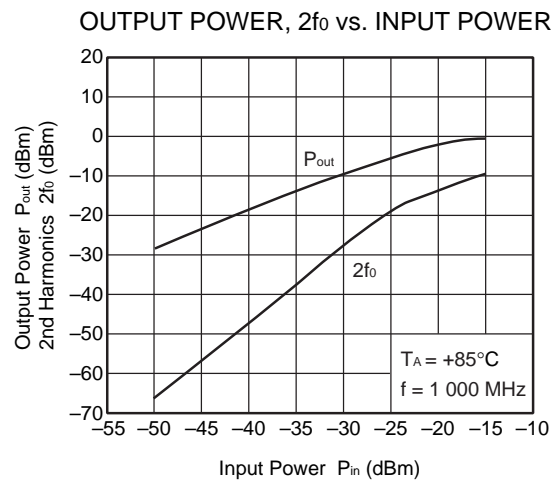
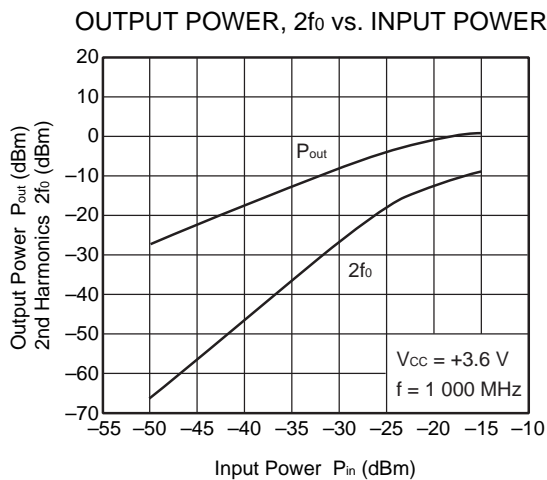
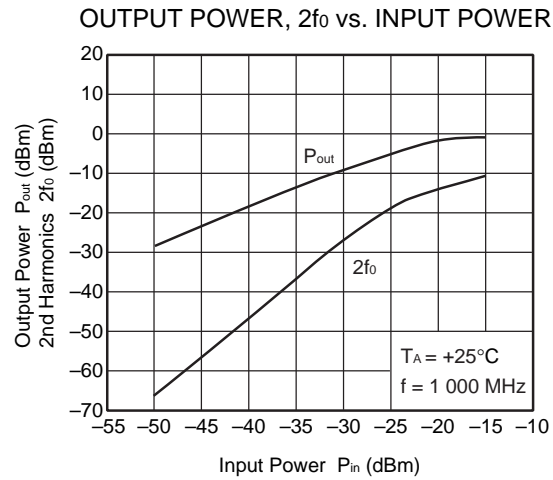
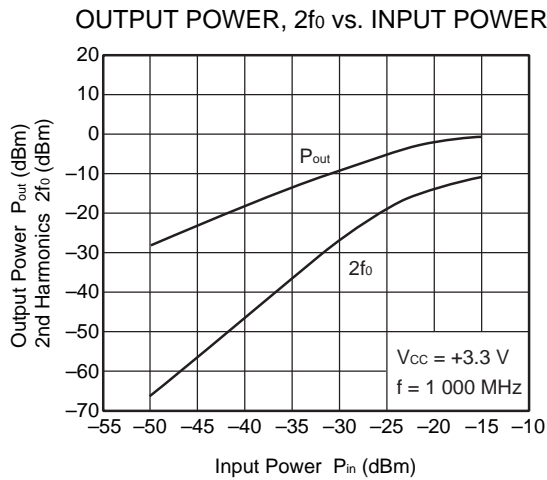
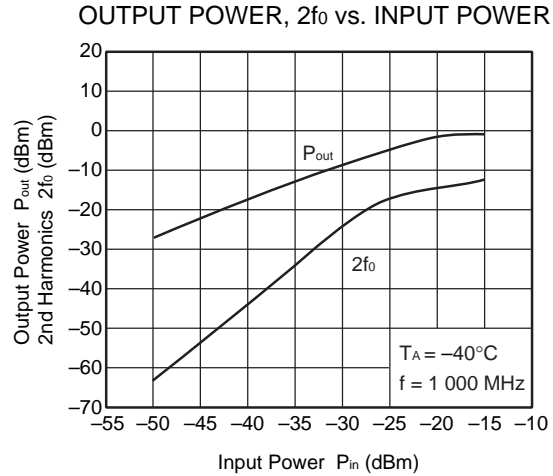
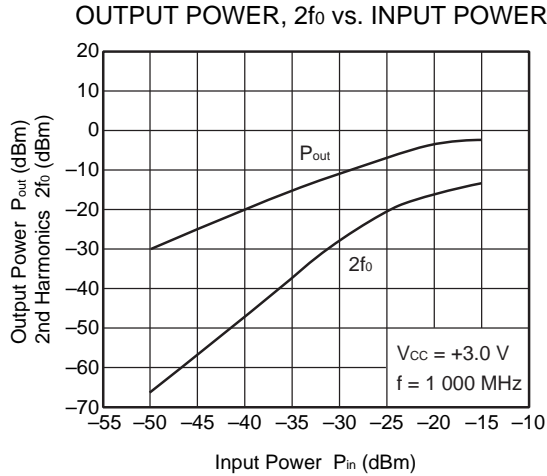

**Remark** The graphs indicate nominal characteristics.

**S-PARAMETERS (T<sub>A</sub> = +25°C, V<sub>CC</sub> = 3.3 V, P<sub>in</sub> = -40 dBm)**

**S<sub>11</sub>-FREQUENCY**

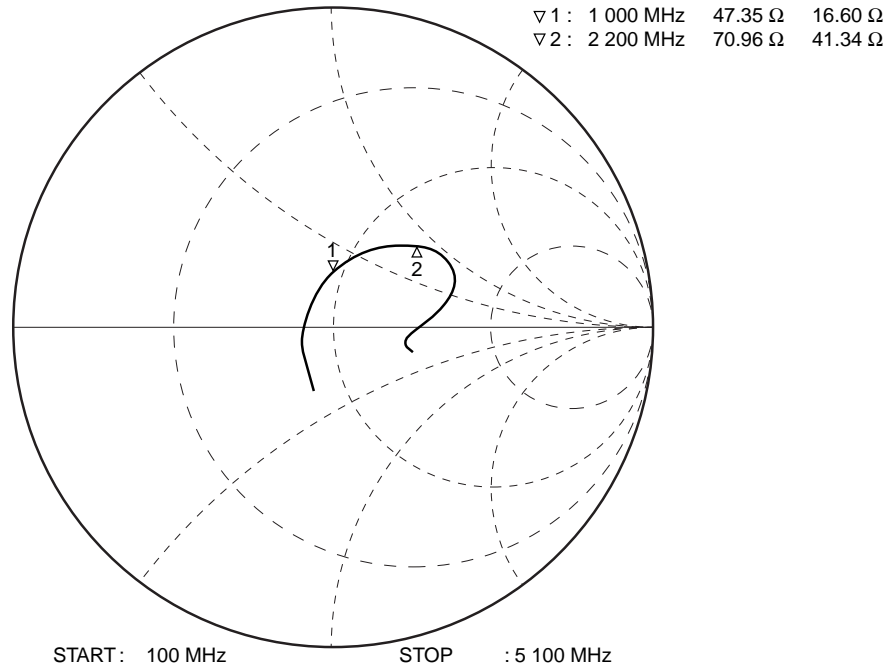

**S<sub>22</sub>-FREQUENCY**

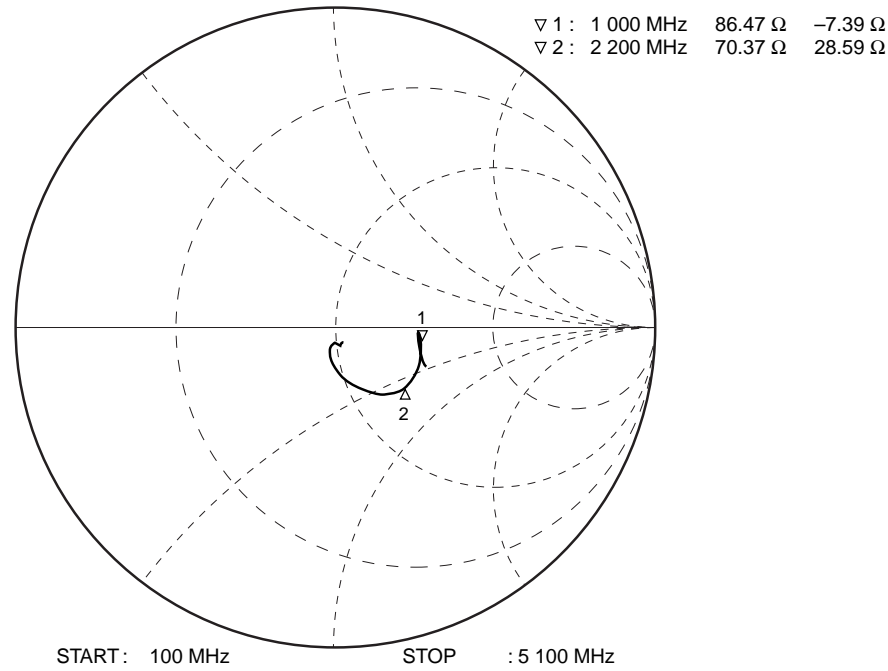

- Remarks 1.** Measured on the test circuit of evaluation board.  
**2.** The graphs indicate nominal characteristics.

**S-PARAMETERS**

S-parameters and noise parameters are provided on our Web site in a format (S2P) that enables the direct import of the parameters to microwave circuit simulators without the need for keyboard inputs.

Click here to download S-parameters.

[RF and Microwave] → [Device Parameters]

URL <http://www.necel.com/microwave/en/>



PACKAGE DIMENSIONS

6-PIN SUPER MINIMOLD (UNIT: mm)

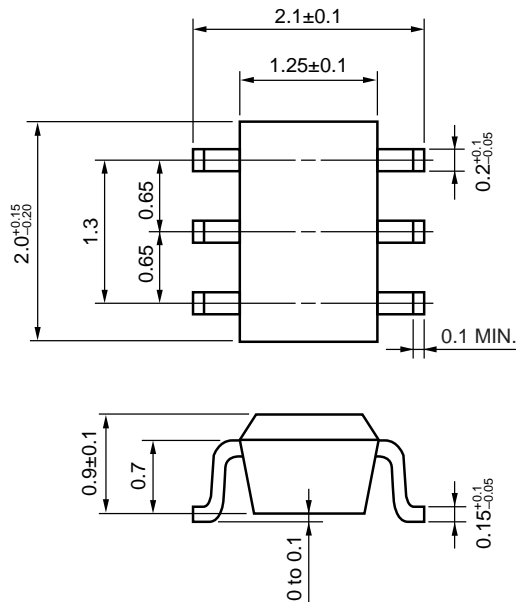

**NOTES ON CORRECT USE**

- (1) Observe precautions for handling because of electro-static sensitive devices.
- (2) Form a ground pattern as widely as possible to minimize ground impedance (to prevent undesired oscillation).  
All the ground terminals must be connected together with wide ground pattern to decrease impedance difference.
- (3) The bypass capacitor should be attached to the Vcc line.
- (4) The DC cut capacitor must be attached to input and output pin.

**RECOMMENDED SOLDERING CONDITIONS**

This product should be soldered and mounted under the following recommended conditions. For soldering methods and conditions other than those recommended below, contact your nearby sales office.

Soldering Method	Soldering Conditions	Condition Symbol
Infrared Reflow	Peak temperature (package surface temperature) : 260°C or below Time at peak temperature : 10 seconds or less Time at temperature of 220°C or higher : 60 seconds or less Preheating time at 120 to 180°C : 120±30 seconds Maximum number of reflow processes : 3 times Maximum chlorine content of rosin flux (% mass) : 0.2%(Wt.) or below	IR260
Wave Soldering	Peak temperature (molten solder temperature) : 260°C or below Time at peak temperature : 10 seconds or less Preheating temperature (package surface temperature) : 120°C or below Maximum number of flow processes : 1 time Maximum chlorine content of rosin flux (% mass) : 0.2%(Wt.) or below	WS260
Partial Heating	Peak temperature (terminal temperature) : 350°C or below Soldering time (per side of device) : 3 seconds or less Maximum chlorine content of rosin flux (% mass) : 0.2%(Wt.) or below	HS350

**Caution Do not use different soldering methods together (except for partial heating).**

- **The information in this document is current as of March, 2010. The information is subject to change without notice. For actual design-in, refer to the latest publications of NEC Electronics data sheets, etc., for the most up-to-date specifications of NEC Electronics products. Not all products and/or types are available in every country. Please check with an NEC Electronics sales representative for availability and additional information.**
- No part of this document may be copied or reproduced in any form or by any means without the prior written consent of NEC Electronics. NEC Electronics assumes no responsibility for any errors that may appear in this document.
- NEC Electronics does not assume any liability for infringement of patents, copyrights or other intellectual property rights of third parties by or arising from the use of NEC Electronics products listed in this document or any other liability arising from the use of such products. No license, express, implied or otherwise, is granted under any patents, copyrights or other intellectual property rights of NEC Electronics or others.
- Descriptions of circuits, software and other related information in this document are provided for illustrative purposes in semiconductor product operation and application examples. The incorporation of these circuits, software and information in the design of a customer's equipment shall be done under the full responsibility of the customer. NEC Electronics assumes no responsibility for any losses incurred by customers or third parties arising from the use of these circuits, software and information.
- While NEC Electronics endeavors to enhance the quality and safety of NEC Electronics products, customers agree and acknowledge that the possibility of defects thereof cannot be eliminated entirely. In addition, NEC Electronics products are not taken measures to prevent radioactive rays in the product design. When customers use NEC Electronics products with their products, customers shall, on their own responsibility, incorporate sufficient safety measures such as redundancy, fire-containment and anti-failure features to their products in order to avoid risks of the damages to property (including public or social property) or injury (including death) to persons, as the result of defects of NEC Electronics products.
- NEC Electronics products are classified into the following three quality grades: "Standard", "Special" and "Specific".

The "Specific" quality grade applies only to NEC Electronics products developed based on a customer-designated "quality assurance program" for a specific application. The recommended applications of an NEC Electronics product depend on its quality grade, as indicated below. Customers must check the quality grade of each NEC Electronics product before using it in a particular application.

"Standard": Computers, office equipment, communications equipment, test and measurement equipment, audio and visual equipment, home electronic appliances, machine tools, personal electronic equipment and industrial robots.

"Special": Transportation equipment (automobiles, trains, ships, etc.), traffic control systems, anti-disaster systems, anti-crime systems, safety equipment and medical equipment (not specifically designed for life support).

"Specific": Aircraft, aerospace equipment, submersible repeaters, nuclear reactor control systems, life support systems and medical equipment for life support, etc.

The quality grade of NEC Electronics products is "Standard" unless otherwise expressly specified in NEC Electronics data sheets or data books, etc. If customers wish to use NEC Electronics products in applications not intended by NEC Electronics, they must contact an NEC Electronics sales representative in advance to determine NEC Electronics' willingness to support a given application.

(Note)

- (1) "NEC Electronics" as used in this statement means NEC Electronics Corporation and also includes its majority-owned subsidiaries.
- (2) "NEC Electronics products" means any product developed or manufactured by or for NEC Electronics (as defined above).