



Features

- High Output Power of 2.0W P1dB
- High Linearity
- High Power-Added Efficiency
- Thermally-Enhanced Packaging
- Broadband Platform Design Approach, 450MHz to 2500MHz

Applications

- GaAs Pre-Driver for Basestation Amplifiers
- PA Stage for Commercial Wireless Infrastructure
- Class AB Operation for NMT, GSM, DCS, PCS, and UMTS Transceiver Applications
- 2nd/3rd Stage LNA for Wireless Infrastructure

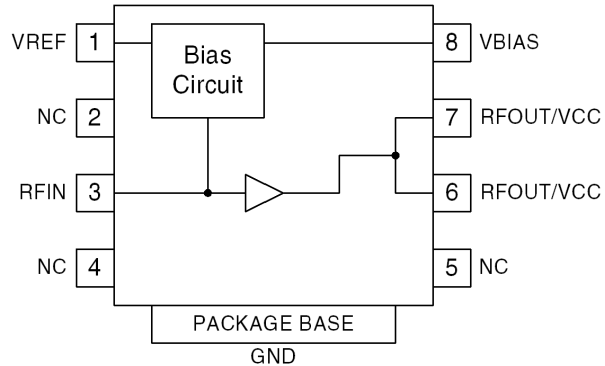

Functional Block Diagram

Product Description

The RF3809 is a GaAs pre-driver power amplifier, specifically designed for wireless infrastructure applications. Using a highly reliable GaAs HBT fabrication process, this high-performance single-stage amplifier achieves high output power over a broad frequency range. The RF3809 also provides excellent efficiency and thermal stability through the use of a thermally-enhanced surface-mount plastic-slug package. Ease of integration is accomplished through the incorporation of an optimized evaluation board design provided to achieve proper 50Ω operation. Various evaluation boards are available to address a broad range of wireless infrastructure applications: NMT 450MHz; GSM850MHz; GSM900MHz; DCS1800MHz; PCS1900MHz; and, UMTS2200MHz.

Ordering Information

RF3809	GaAs HBT Pre-Driver Amplifier
RF3809PCK-410	Fully Assembled Evaluation Board, 450MHz
RF3809PCK-411	Fully Assembled Evaluation Board, 869MHz to 894MHz
RF3809PCK-412	Fully Assembled Evaluation Board, 920MHz to 960MHz
RF3809PCK-413	Fully Assembled Evaluation Board, 1800MHz to 1880MHz
RF3809PCK-414	Fully Assembled Evaluation Board, 1930MHz to 1990MHz
RF3809PCK-415	Fully Assembled Evaluation Board, UMTS

Optimum Technology Matching® Applied

- | | | | |
|--|--------------------------------------|-------------------------------------|-----------------------------------|
| <input checked="" type="checkbox"/> GaAs HBT | <input type="checkbox"/> SiGe BiCMOS | <input type="checkbox"/> GaAs pHEMT | <input type="checkbox"/> GaN HEMT |
| <input type="checkbox"/> GaAs MESFET | <input type="checkbox"/> Si BiCMOS | <input type="checkbox"/> Si CMOS | <input type="checkbox"/> RF MEMS |
| <input type="checkbox"/> InGaP HBT | <input type="checkbox"/> SiGe HBT | <input type="checkbox"/> Si BJT | <input type="checkbox"/> LDMOS |

RF MICRO DEVICES®, RFMD®, Optimum Technology Matching®, Enabling Wireless Connectivity™, PowerStar®, POLARIS™ TOTAL RADIO™ and UltimateBlue™ are trademarks of RFMD, LLC. BLUETOOTH is a trademark owned by Bluetooth SIG, Inc., U.S.A. and licensed for use by RFMD. All other trade names, trademarks and registered trademarks are the property of their respective owners. ©2006, RF Micro Devices, Inc.

Absolute Maximum Ratings

Parameter	Rating	Unit
Supply Voltage	9.0	V
Reference Current (I_{REF})	30	mA
RF - Input Power	See below	
Operating Current	750	mA
Load VSWR	4:1	
Operating Temperature	-40 to +85	°C
Storage Temperature	-40 to +105	°C



Caution! ESD sensitive device.

Exceeding any one or a combination of the Absolute Maximum Rating conditions may cause permanent damage to the device. Extended application of Absolute Maximum Rating conditions to the device may reduce device reliability. Specified typical performance or functional operation of the device under Absolute Maximum Rating conditions is not implied.

RoHS status based on EUDirective2002/95/EC (at time of this document revision).

The information in this publication is believed to be accurate and reliable. However, no responsibility is assumed by RF Micro Devices, Inc. ("RFMD") for its use, nor for any infringement of patents, or other rights of third parties, resulting from its use. No license is granted by implication or otherwise under any patent or patent rights of RFMD. RFMD reserves the right to change component circuitry, recommended application circuitry and specifications at any time without prior notice.

Parameter	Specification			Unit	Condition
	Min.	Typ.	Max.		
Overall - 450MHz					
Frequency	420		480	MHz	$I_{REF}=15\text{mA}$, $V_{CC}=8\text{V}$, $V_{REF}=8\text{V}$, $V_{BIAS}=8\text{V}$, Temp = +25°C
P1dB		+33.0		dBm	
P_{IN} , Maximum			24.0	dBm	
Total Efficiency		45.0		%	@P1dB
Total Power Added Efficiency		44.0		%	@P1dB
Gain (S21)		13		dB	
Second Harmonic (2fo)		-27		dBc	@P1dB
Third Harmonic (3fo)		-36		dBc	@P1dB
Input Return Loss (S11)		-16		dB	
Output Return Loss (S22)		-5.5		dB	
Two-Tone Specification					
OIP3		46.5		dBm	19dBm/tone

Parameter	Specification			Unit	Condition
	Min.	Typ.	Max.		
Overall - GSM800					
Frequency	869		894	MHz	$I_{REF}=15\text{mA}$, $V_{CC}=8\text{V}$, $V_{REF}=8\text{V}$, $V_{BIAS}=8\text{V}$, Temp = +25 °C
P1dB	33	35		dBm	Frequency=880MHz
P_{IN} , Maximum			24	dBm	
Total Efficiency		50.5		%	@P1dB
Total Power Added Efficiency		49.5		%	@P1dB
Gain (S21)	12.5	13.5	14.5	dB	Frequency=880MHz
Second Harmonic (2fo)		-28.0		dBc	@P1dB
Third Harmonic (3fo)		-38.0		dBc	@P1dB
Input Return Loss (S11)		-18.0		dB	
Output Return Loss (S22)		-13.0		dB	
Two-Tone Specification					
OIP3	43.5	45.5		dBm	19dBm/tone, Frequency=880MHz
Overall - GSM900					
Frequency	920		960	MHz	$I_{REF}=14\text{mA}$, $V_{CC}=8\text{V}$, $V_{REF}=8\text{V}$, $V_{BIAS}=8\text{V}$, Temp = +25 °C
P1dB		+34.5		dBm	
P_{IN} , Maximum			24	dBm	
Total Efficiency		49.0		%	@P1dB
Total Power Added Efficiency		48.0		%	@P1dB
Gain (S21)		13.5		dB	
Second Harmonic (2fo)		-28.0		dBc	@P1dB
Third Harmonic (3fo)		-29.5		dBc	@P1dB
Input Return Loss (S11)		-21.0		dB	
Output Return Loss (S22)		-8.0		dB	
Two-Tone Specification					
OIP3		48.5		dBm	19dBm/tone

Parameter	Specification			Unit	Condition
	Min.	Typ.	Max.		
Overall - DCS1800					
Frequency	1805		1880	MHz	$I_{REF}=15\text{mA}$, $V_{CC}=8\text{V}$, $V_{REF}=8\text{V}$, $V_{BIAS}=8\text{V}$, Temp = +25°C
P1dB		+34.0		dBm	
P_{IN} , Maximum			26	dBm	
Total Efficiency		50.0		%	@P1dB
Total Power Added Efficiency		49.0		%	@P1dB
Gain (S21)		11.5		dB	
Second Harmonic (2fo)		-24.0		dBc	@P1dB
Third Harmonic (3fo)		-48.0		dBc	@P1dB
Input Return Loss (S11)		-15.0		dB	
Output Return Loss (S22)		-12.0		dB	
Two-Tone Specification					
OIP3		47.0		dBm	19dBm/tone
Overall - PCS1900					
Frequency	1930		1990	MHz	$I_{REF}=15\text{mA}$, $V_{CC}=8\text{V}$, $V_{REF}=8\text{V}$, $V_{BIAS}=8\text{V}$, Temp = +25°C
P1dB		+32.5		dBm	
P_{IN} , Maximum			26	dBm	
Total Efficiency		47.5		%	@P1dB
Total Power Added Efficiency		46.5		%	@P1dB
Gain (S21)		10.5		dB	
Second Harmonic (2fo)		-26.0		dBc	@P1dB
Third Harmonic (3fo)		-65.0		dBc	@P1dB
Input Return Loss (S11)		-12.0		dB	
Output Return Loss (S22)		-9.0		dB	
Two-Tone Specification					
OIP3		45.5		dBm	19dBm/tone

Parameter	Specification			Unit	Condition
	Min.	Typ.	Max.		
UMTS 2100					
Frequency	2110		2170	MHz	$I_{REF}=15\text{mA}$, $V_{CC}=8\text{V}$, $V_{REF}=8\text{V}$, $V_{BIAS}=8\text{V}$, Temp= $+25^{\circ}\text{C}$
P1dB		+32.5		dBm	
P_{IN} , Maximum			26	dBm	
Total Efficiency		47.5		%	@P1dB
Total Power Added Efficiency		46.5		%	@P1dB
Gain (S21)		10		dB	
Second Harmonic (2fo)		-32.0		dBc	@P1dB
Third Harmonic (3fo)		-52.0		dBc	@P1dB
Input Return Loss (S11)		-15.0		dB	
Output Return Loss (S22)		-11.0		dB	
Two-Tone Specification					
OIP3		44.5		dBm	19dBm/tone
Power Supply					
Power Supply Voltage	4.5	8	9	V	
Supply Current ($I_{CC}+I_{BIAS}$)	180	270	316	mA	$V_{CC}=V_{REF}=V_{BIAS}=8\text{V}$, $R_{BIAS}=300\Omega$
Control Current (I_{REF})		15		mA	$V_{CC}=V_{REF}=V_{BIAS}=8\text{V}$, $R_{BIAS}=300\Omega$
Power Down Current			30	μA	$V_{REF}=0\text{V}$, $V_{CC}=8\text{V}$

Bias Table

V_{CC}	V_{BIAS}	V_{REF}	V_{REF_PIN}	R_{BIAS}	I_{REF}	I_{CQ}	Comments
8	8	8	3.5	300	15	258	
5	5	5	3.825	47	25	265	For equivalent I_{CQ} to 8V case

Pin	Function	Description
1	VREF	Control input to internal bias circuitry.
2	NC	No connection.
3	RFIN	Input for RF signal.
4	NC	No connection.
5	NC	No connection.
6	RFOUT/VCC	RF output pin and V _{CC} supply pin.
7	RFOUT/VCC	RF output pin and V _{CC} supply pin.
8	VBIAS	RF supply to internal bias circuitry.
Pkg Base	GND	Backside of package should be connected to a short path to ground.

Theory of Operation and Application Information

RF3809 design accommodates use in a variety of applications:

- Linear driver from 450MHz to 2500MHz
- 2nd/3rd stage high linearity LNA, with noise figure in the 3dB to 4dB range from 800MHz to 2200MHz
- High efficiency (>50%) output stage for non-linear applications

Nominal data sheet shows specification for $V_{CC}=V_{BIAS}=V_{REF}=8V$. RF3809 can easily be configured for 5V operation, with a simple bias resistor change at V_{REF} . “Bias Table” on page 5 shows resistor values for $V_{CC}=V_{BIAS}=V_{REF}=5V$. Generally speaking, 5V data will compare to that for 8V as follows:

- 3dB to 3.5dB reduction in OP1dB
- 0.4dB to 0.5dB increase in small signal gain

For operation at other than 5V, bias R can be calculated as follows ($V_{CC}=V_{BIAS}=V_{REF}=5V$ is used here to illustrate, operation at different voltage is determined with same methodology).

1. Use nominal 8V case as a starting point: $V_{CC}=V_{BIAS}=V_{REF}=8V$, $I_{REF}=15mA$, $I_{CQ}=258mA$. Target condition will be to achieve same I_{CQ} with $V_{CC}=V_{BIAS}=V_{REF}=5V$.
2. Using evaluation board with separate lab supplies on (V_{CC}/V_{BIAS}) and (V_{REF}), set $V_{CC}/V_{BIAS}=5V$, $V_{REF}=8V$. I_{REF} is maintained at 15mA, and I_{CQ} drops from nominal value of 258mA.
3. V_{REF} can then be increased >8V until I_{CQ} is restored. I_{REF} increase to 23mA is required (as seen in “Bias Table” on page 5).
4. At this point, pin voltage at V_{REF} is calculated (or measured with DVM): $V_{PIN}=V_{REF}$ at eval board input – $I_{REF} * \text{bias R} = 10.8 - 0.023 * 300 = 3.9V$.
5. Next, calculate new bias R for $V_{REF}=5V$: $\text{Bias R} = (5 - 3.9) / 0.023 = 47.8\Omega$. See “Bias Table” on page 5, standard resistor value = 47Ω is called out. In this way, bias R can be calculated for any $V_{CC}=V_{BIAS}=V_{REF}$ configuration. The maximum I_{REF} limit for RF3809 = 30mA.

Junction-to-case thermal resistance ($R_{TH_{JC}}$) is shown versus output power in the graph section of this data sheet. The graph was generated with nominal $V_{CC}=V_{BIAS}=V_{REF}=8V$, $I_{REF}=15mA$, where ambient temperature = $85^{\circ}C$. Using this curve along with operating condition, junction temperature can be calculated. Resultant T_J for this case yields $MTTF \geq 100$ years. Standard RF3809 evaluation boards are matched for high efficiency at O_{P1dB} . To ensure reliability for operation at high power, output match achieving equivalent or better efficiency on system board should be the goal.

Typical s-parameter responses for each evaluation board are shown within the data sheet. These boards were matched with two specifications in mind:

- Output load impedance set for optimum OIP_3/ACP (Adjacent Channel Power for commonly used modulation standards).
- Output load impedance set for high efficiency at O_{P1dB} , with ruggedness (survival) into output 4:1 VSWR.

In some cases, low power operation being one, it may be desirable to improve output return loss seen on evaluation board. This can be done with output match adjust. The result will be an increase in small signal gain. Tradeoffs between return loss, gain, OIP_3 , and compression point can then be considered in obtaining optimum performance for a particular application.

Finally, infrastructure qualification report for RF3809 can be obtained by contacting RFMD.

Package Drawing

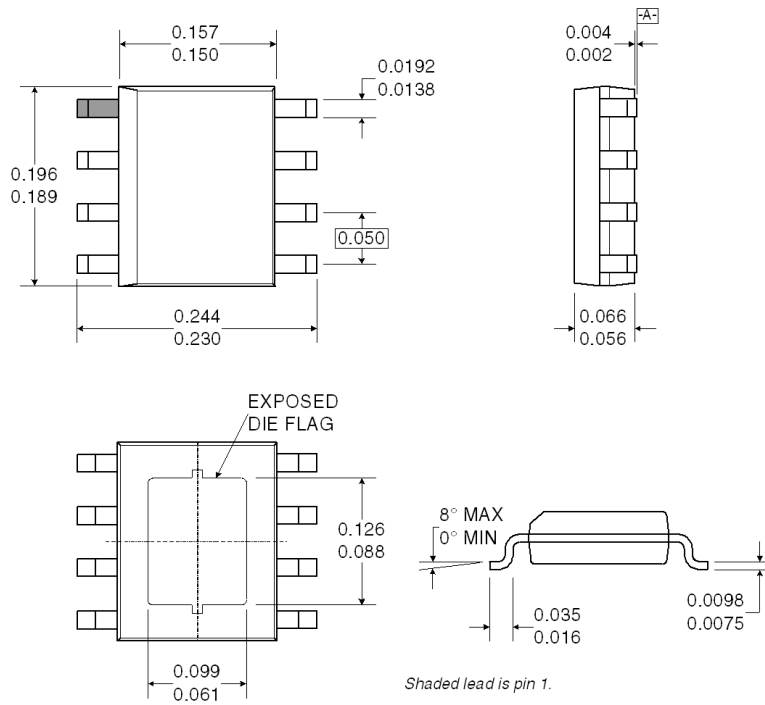

Evaluation Board Schematic
400MHz (RF3809410)

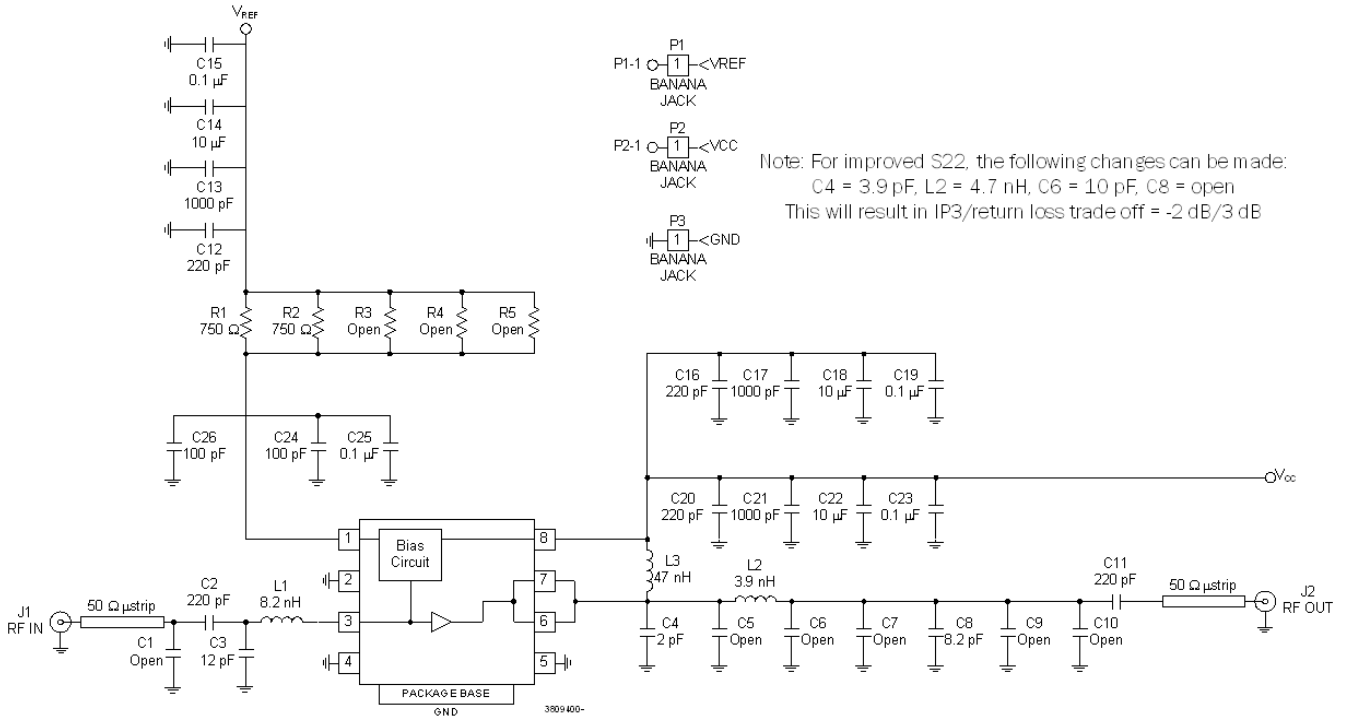

Evaluation Board Schematic
800MHz to 1000MHz (CDMA800, ISM, EGSM)

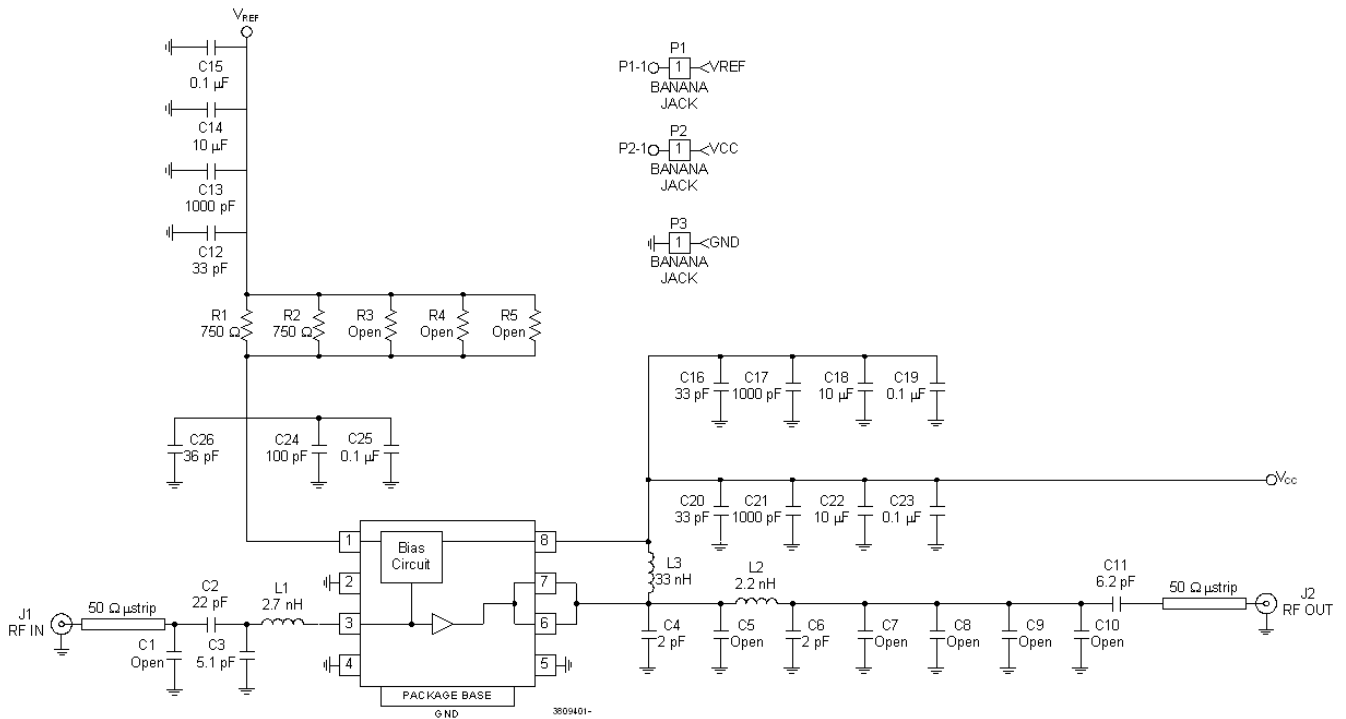

Evaluation Board Schematic 869MHz to 894MHz (GSM800) (RF3809411)

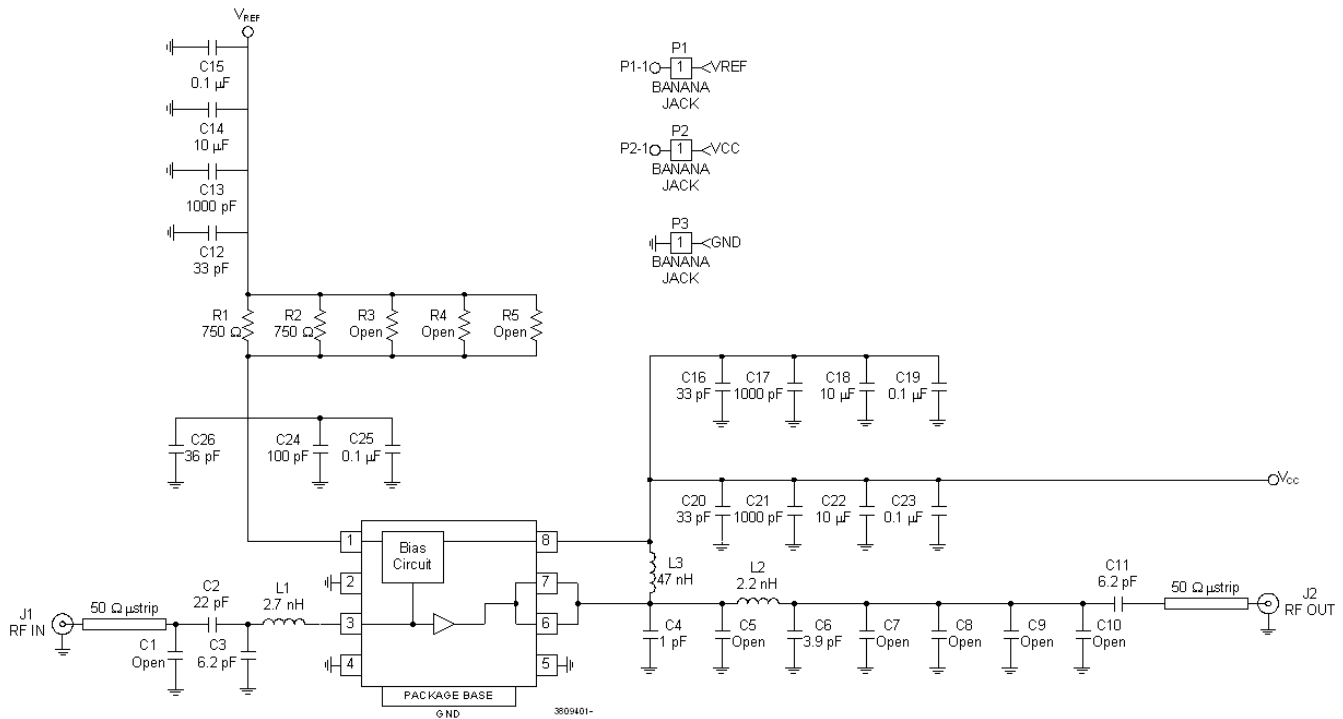

Evaluation Board Schematic 920MHz to 960MHz (GSM900) (RF3809412)

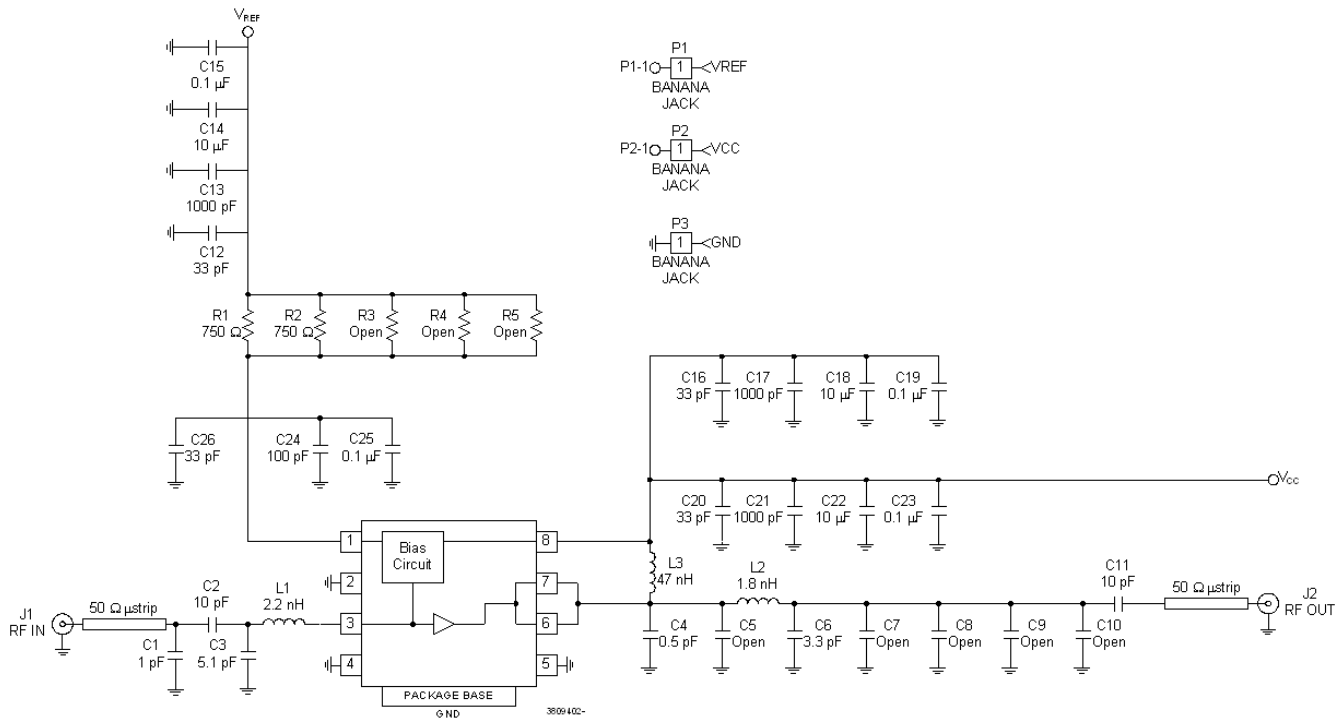

Evaluation Board Schematic
1805MHz to 1880MHz (DCS1800) (RF3809413)

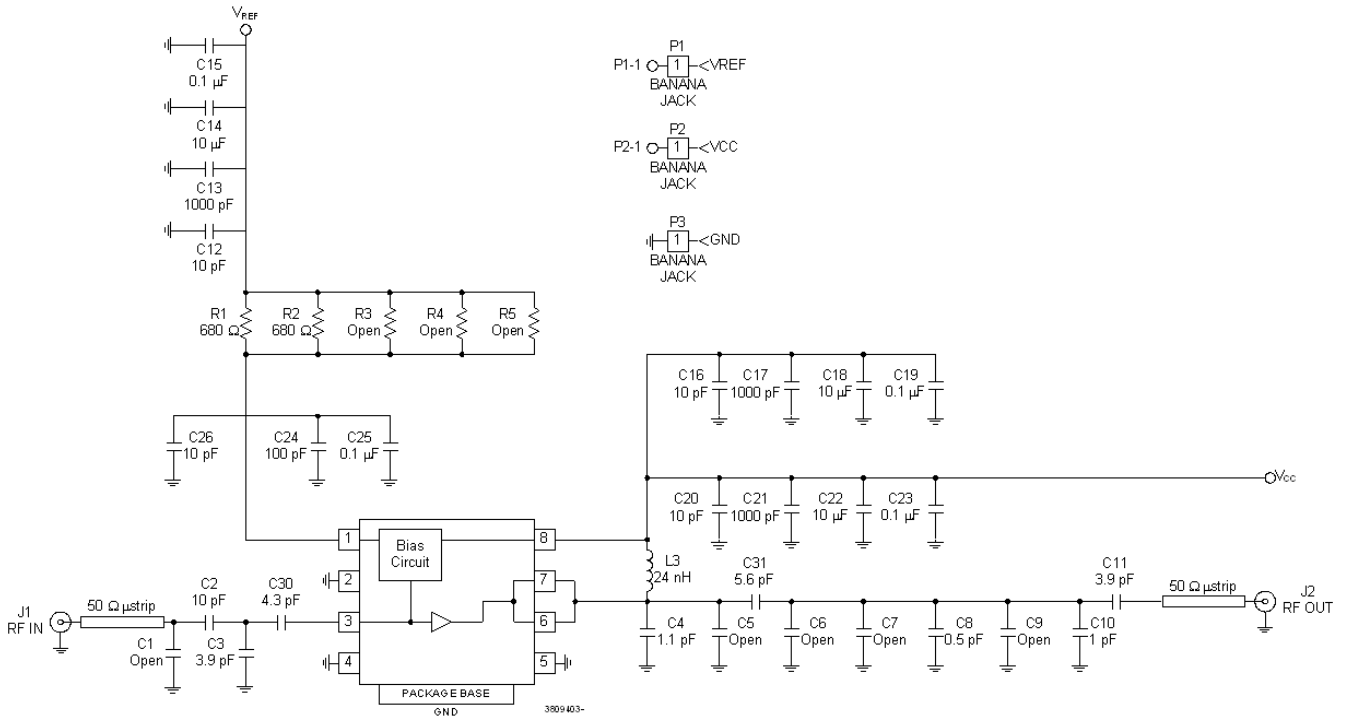

Evaluation Board Schematic
1930MHz to 1990MHz (PCS1900) (RF3809414)

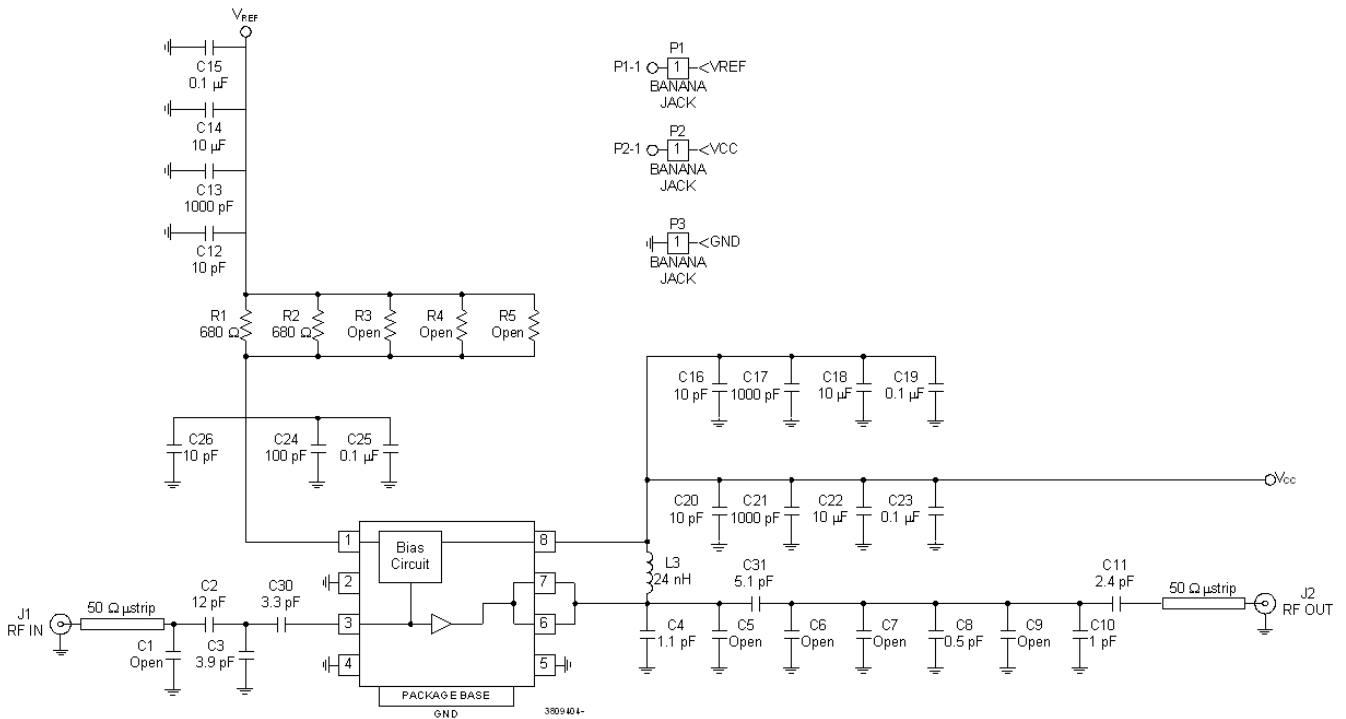

Evaluation Board Schematic UMTS (RF3809415)

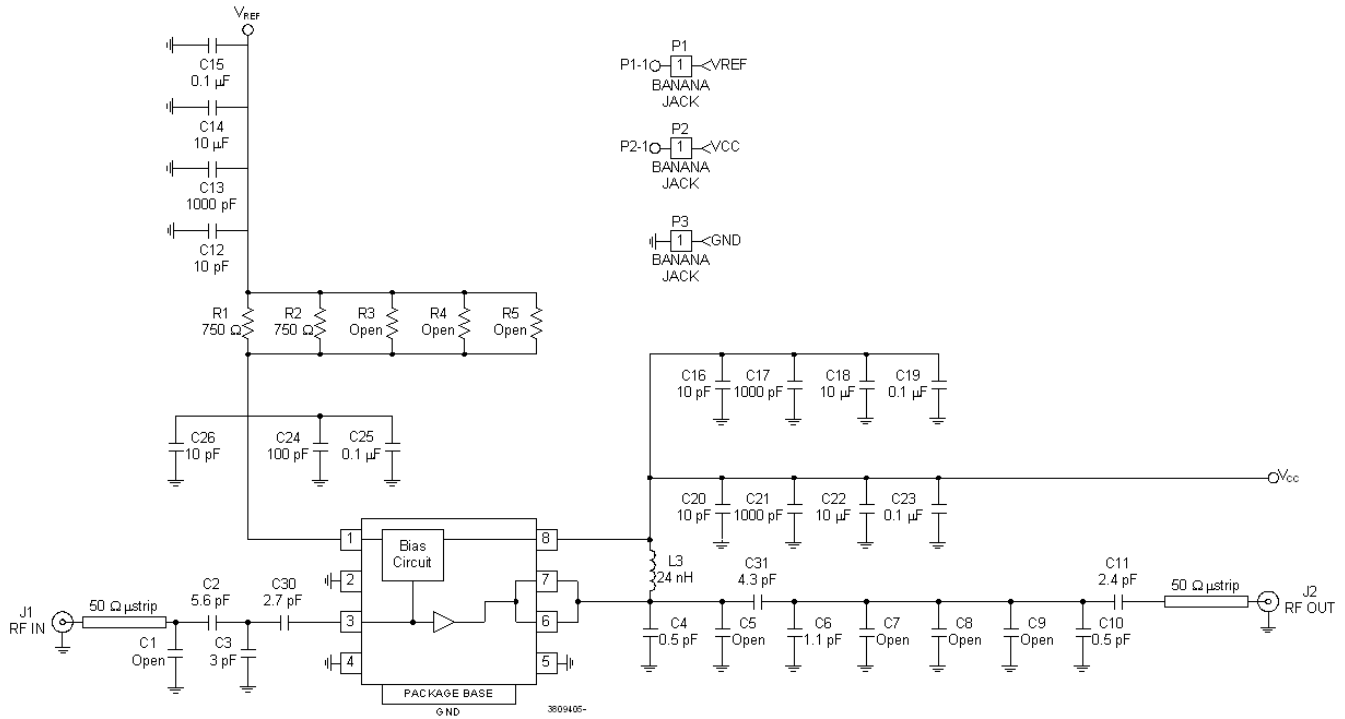

Evaluation Board Layout
Board Size 2.0" x 2.0"

Board Thickness 0.023", Board Material Rogers 4530

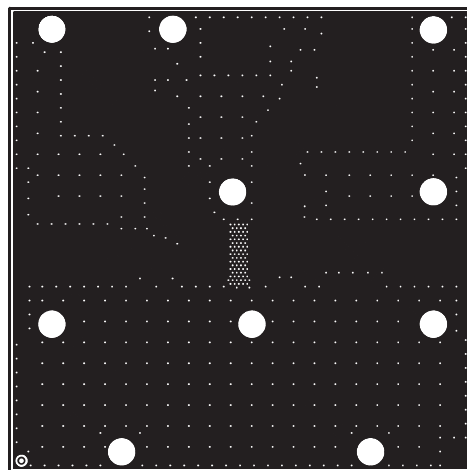
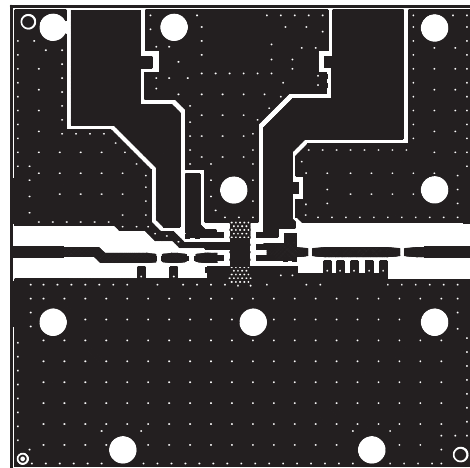
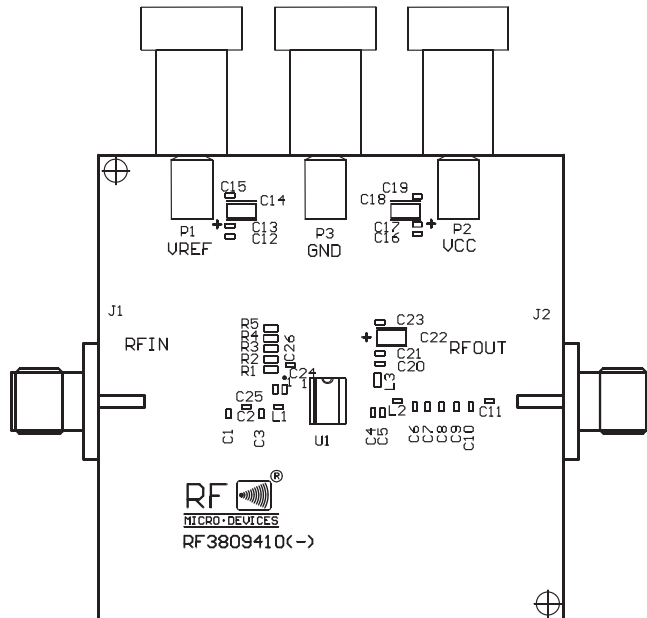

PCB Design Requirements

PCB Surface Finish

The PCB surface finish used for RFMD's qualification process is electroless nickel, immersion gold. Typical thickness is 3µinch to 8µinch gold over 180µinch nickel.

PCB Land Pattern Recommendation

PCB land patterns for PFMD components are based on IPC-7351 standards and RFMD empirical data. The pad pattern shown has been developed and tested for optimized assembly at RFMD. The PCB land pattern has been developed to accommodate lead and package tolerances. Since surface mount processes vary from company to company, careful process development is recommended.

PCB Metal Land Pattern

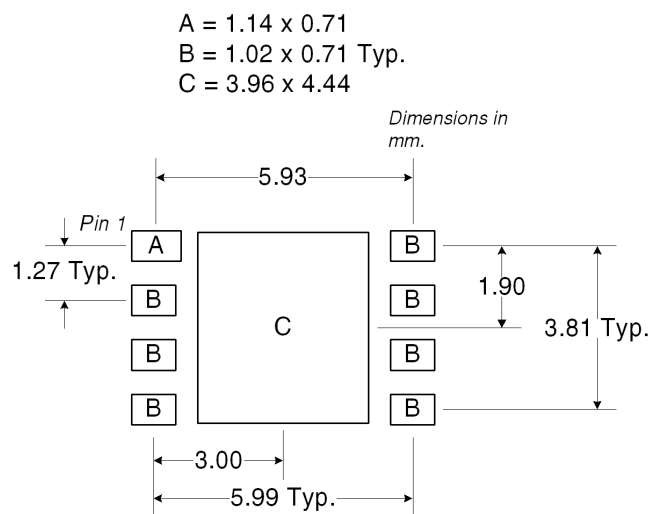

PCB Solder Mask Pattern

Liquid Photo-Imageable (LPI) solder mask is recommended. The solder mask footprint will match what is shown for the PCB metal land pattern with a 2mil to 3mil expansion to accommodate solder mask registration clearance around all pads. The center-grounding pad shall also have a solder mask clearance. Expansion of the pads to create solder mask clearance can be provided in the master data or requested from the PCB fabrication supplier.

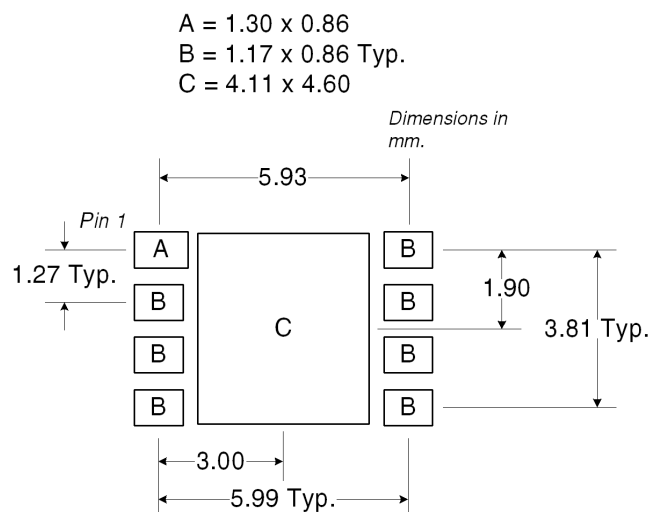

Thermal Pad and Via Design

The DUT must be connected to the PCB backside ground through a low inductance, low thermal resistance path. The required interface is achieved with the via pattern shown below for both low inductance as well as low thermal resistance. The footprint provided below worked well on the RFMD 20mil thick Rogers 4350 PCB and also standard FR4. The vias are 8mil vias that are partially plated through and are finished to 8mils±2mils with a minimum plating of 1.5mil. Failure to place these vias within the DUT mounting area on the PCB in this prescribed manner may result in electrical performance and/or reliability degradation.

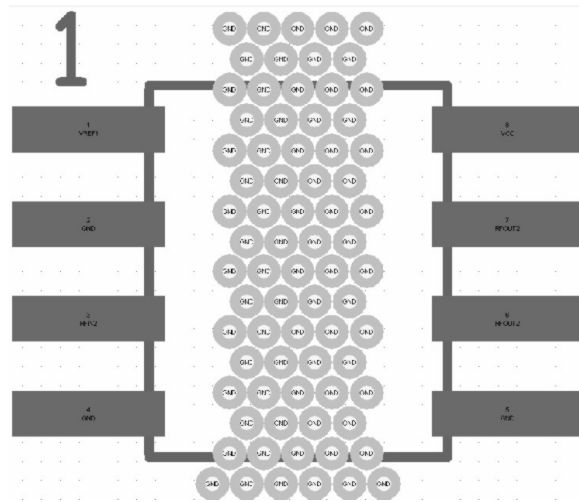

Tape and Reel Information

Carrier tape basic dimensions are based on EIA481. The pocket is designed to hold the part for shipping and loading onto SMT manufacturing equipment, while protecting the board and the solder terminals from damaging stresses. The individual pocket design can vary from vendor to vendor, but width and pitch will be consistent.

Carrier tape is wound or placed on a shipping reel with a diameter of either 330mm (13inches) or 178mm (7inches). The center hub design is large enough to ensure the radius formed by the carrier tape around it does not put unnecessary stress on the parts.

Prior to shipping, moisture sensitive parts (MSL level 2a to 5a) are baked and placed into the pockets of the carrier tape. A cover tape is sealed over the top of the entire length of the carrier tape. The reel is sealed in a moisture barrier, ESD bag, which is placed in a cardboard shipping box. It is important to note that unused moisture sensitive parts need to be resealed in the moisture barrier bag. If the reels exceed the exposure limit and need to be rebaked, most carrier tape and shipping reels are not rate as bakeable at 125 °C. If baking is required, devices may be baked according to section 4, table 4-1, column 8 of Joint Industry Standard IPC/JEDECJ-STD-033A.

The following table provides useful information for carrier tape and reels used for shipping the devices described in this document.

RFMD Part Number	Reel Diameter Inch (mm)	Hub Diameter Inch (mm)	Width (mm)	Pocket Pitch (mm)	Feed	Units per Reel
RF3809TR13	13 (330)	4 (102)	12	8	Single	2500
RF3809TR7	7 (178)	2.4 (61)	12	8	Single	750

Carrier Tape Drawing with Part Orientation

Notes:

- 1. All dimensions are in millimeters (mm).
- 2. Unless otherwise specified, all dimension tolerances per EIA-481.

$A_o = 6.70 \pm 0.10$
 $B_o = 5.40 \pm 0.10$
 $F = 5.50 \pm 0.05$
 $K_o = 2.10 \pm 0.10$
 $P = 8.00 \pm 0.10$
 $W = 12.00 +0.30/-0.10$

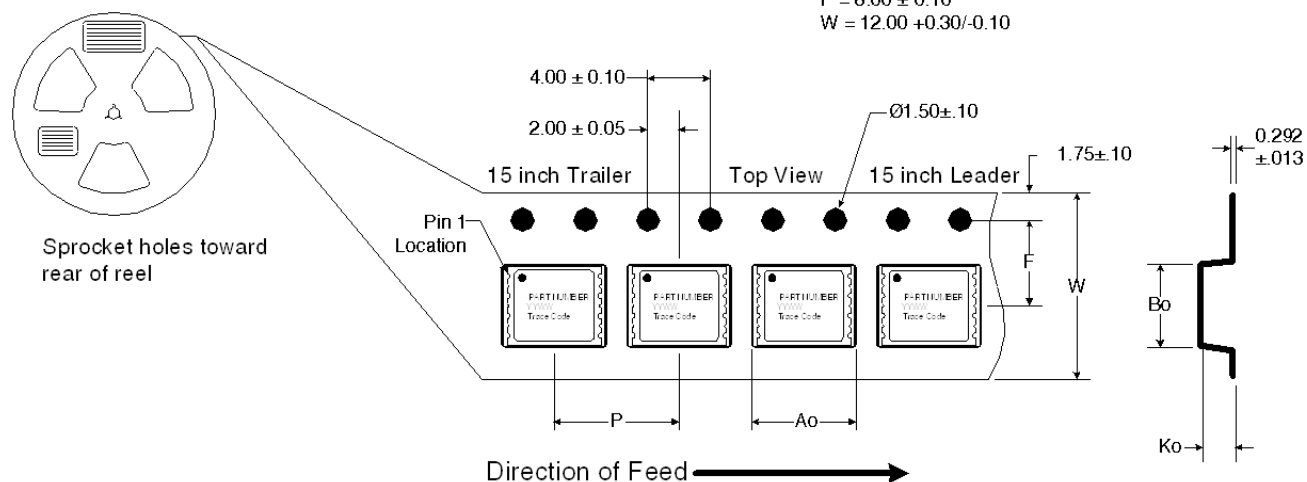

RF3809410 Evaluation Board S-Parameters

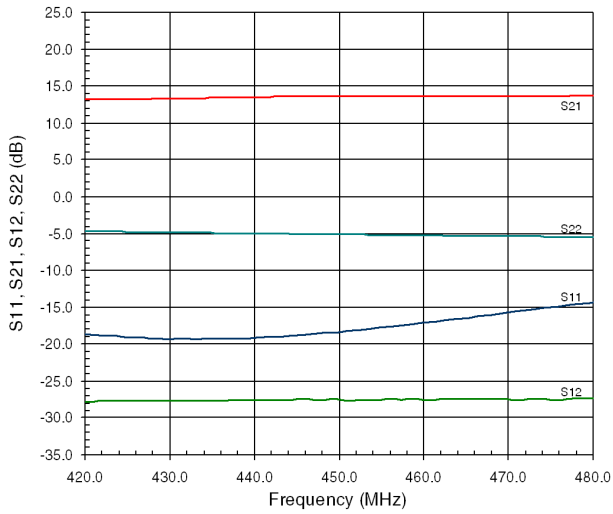

RF3809411 Evaluation Board S-Parameters

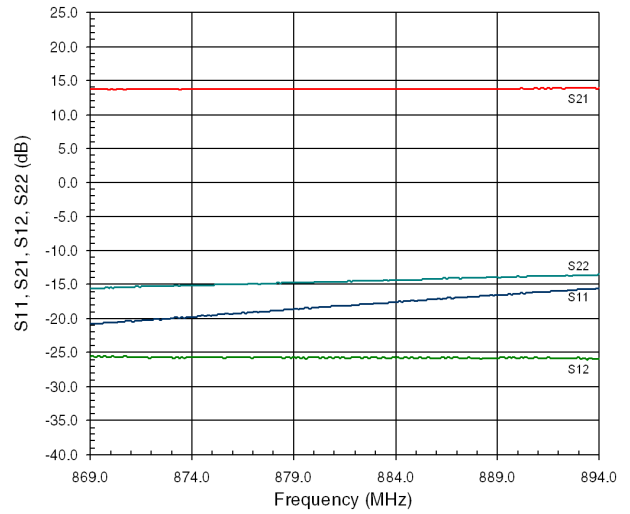

RF3809412 Evaluation Board S-Parameters

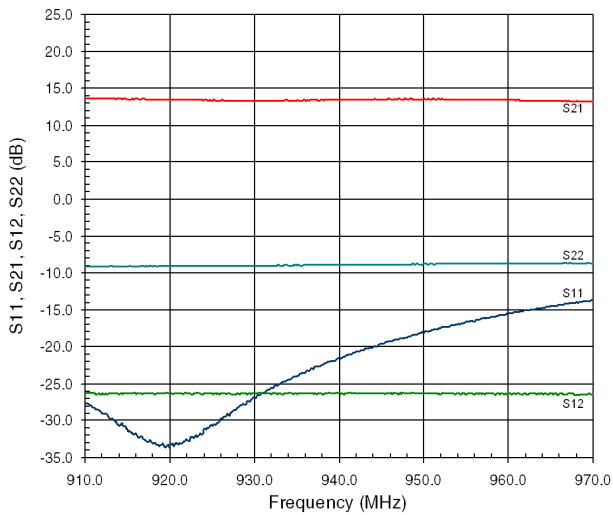

RF3809413 Evaluation Board S-Parameters

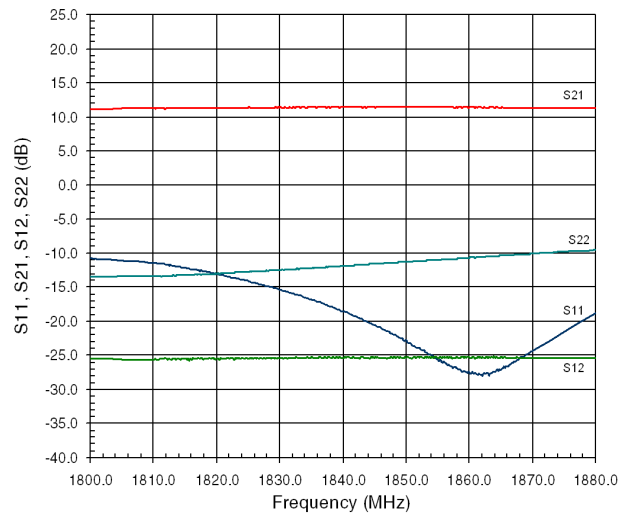

RF3809414 Evaluation Board S-Parameters

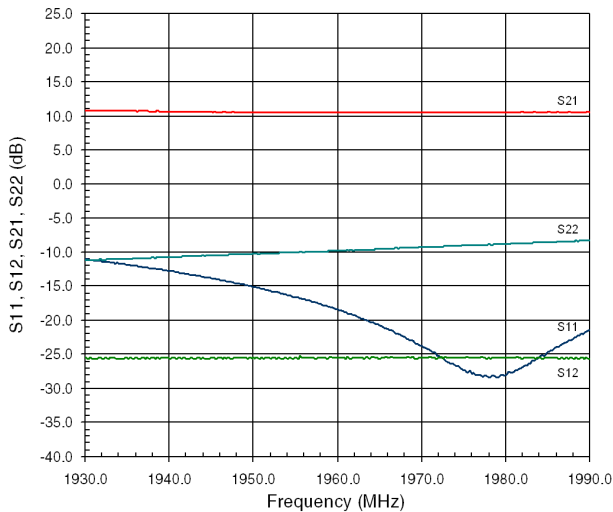

RF3809415 Evaluation Board S-Parameters

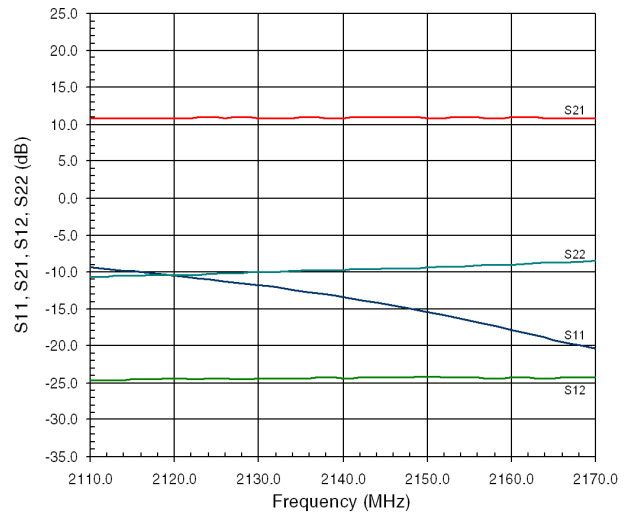

CDMA2K ACPR Performance for RS SMIQ03HD Sig Gen & FSU8 Spec Analyzer (1960 MHz, 882 MHz, & 450 MHz Source Signals)

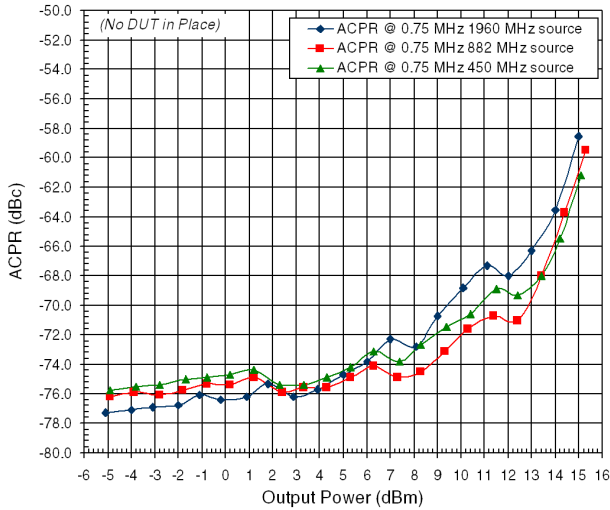

W-CDMA ACPR Performance for RS SMIQ03HD Sig Gen & FSU8 Spec Analyzer (2140 MHz & 882 MHz Source Signals)

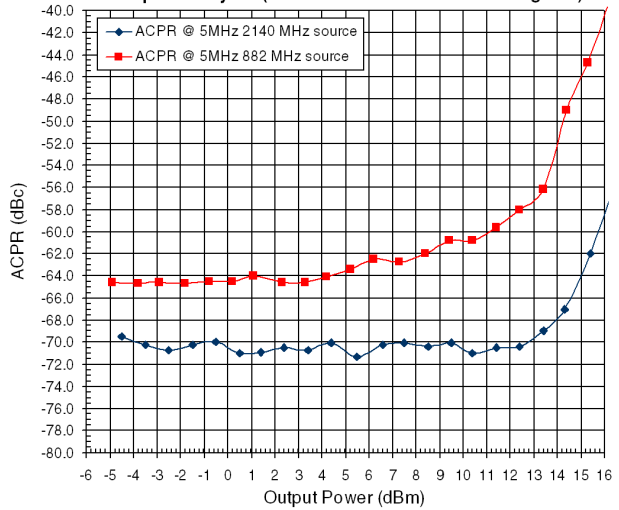

**RF3809410 @ 450 MHz CDMA2K
SR1 and 9 Channels**

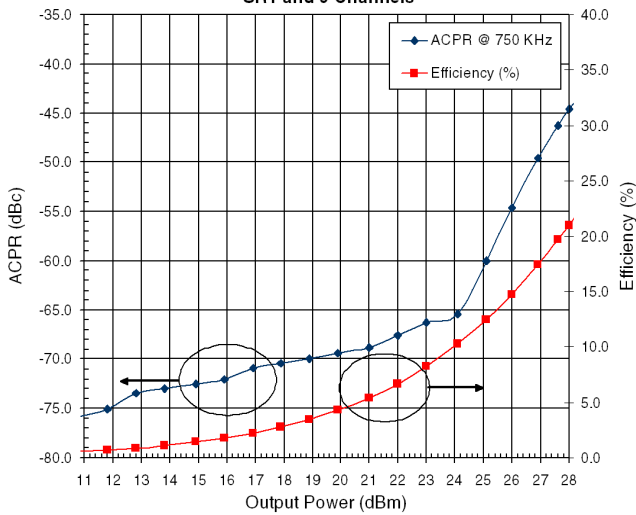

**RF3809411 @ 882 MHz CDMA2K
SR1 and 9 Channels**

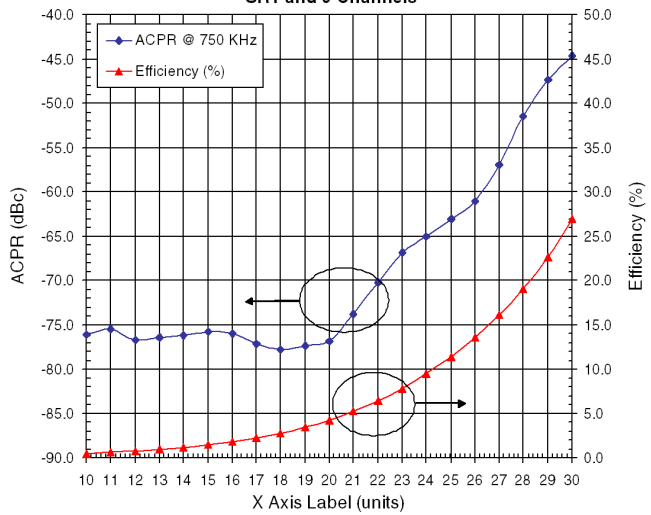

**3809411 @ 882 MHz W-CDMA
64 Channels and No Clipping**

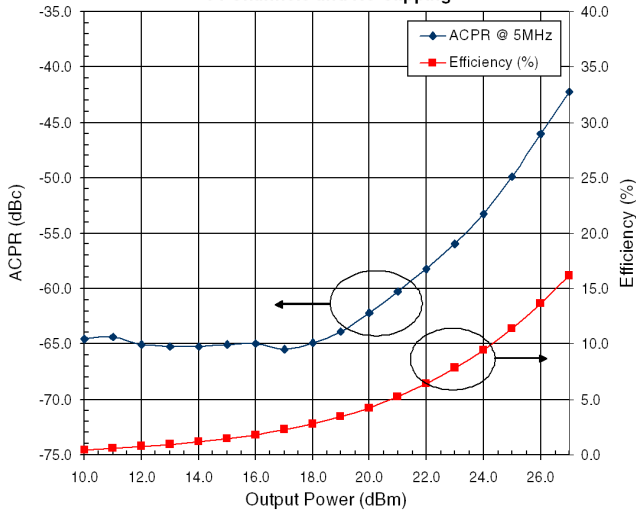

**RF3809412 @ 940 MHz
EDGE EVM**

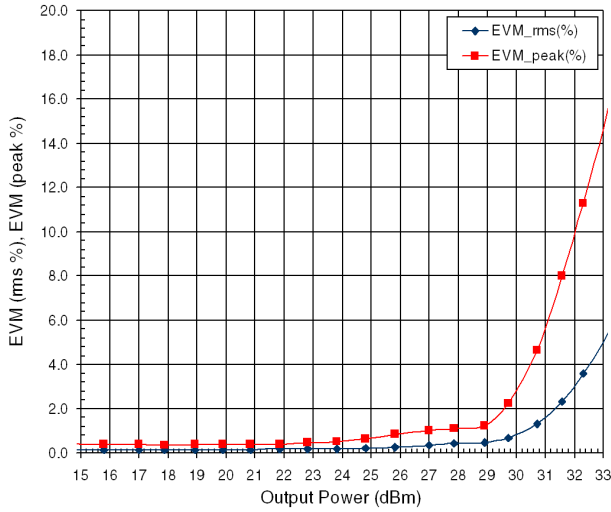

**RF3809413 @ 1840 MHz
EDGE EVM**

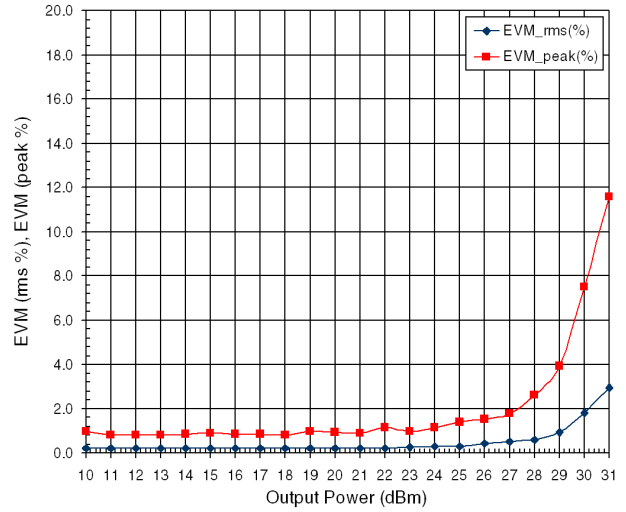

**RF3809414 @ 1960 MHz CDMA2K
SR1 and 9 Channels**

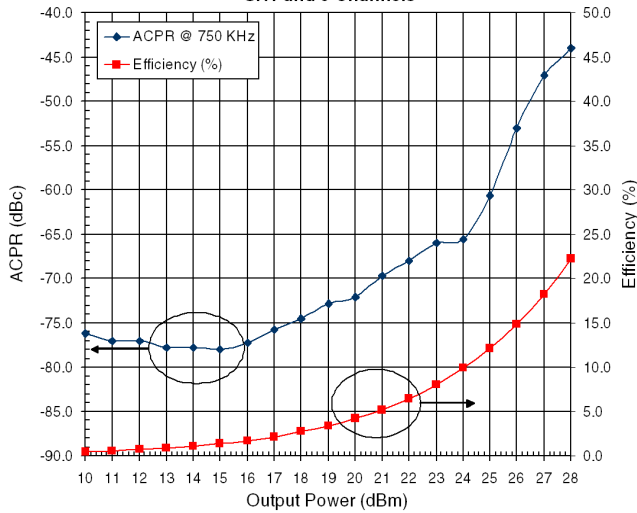

**RF3809415 @ 2140 MHz W-CDMA UMTS
64 Channels and No Clipping**

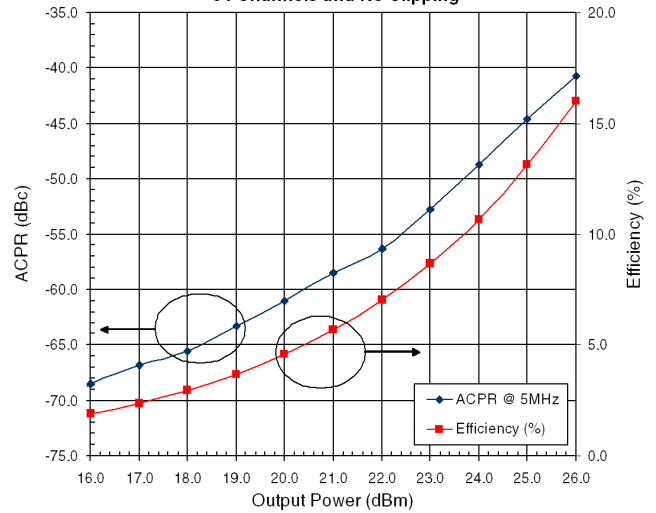

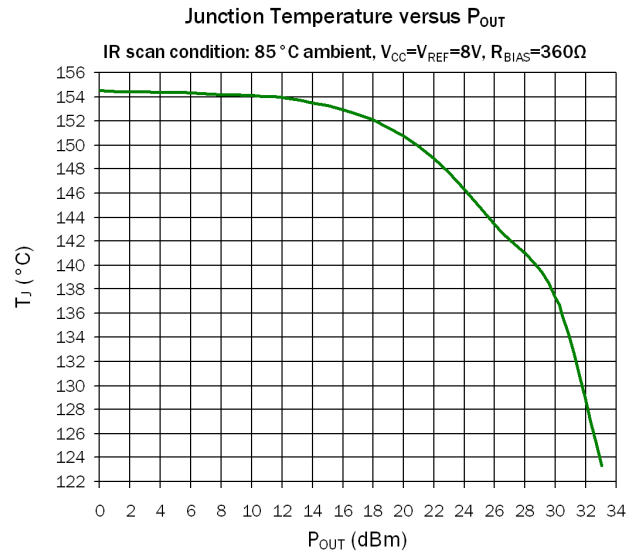
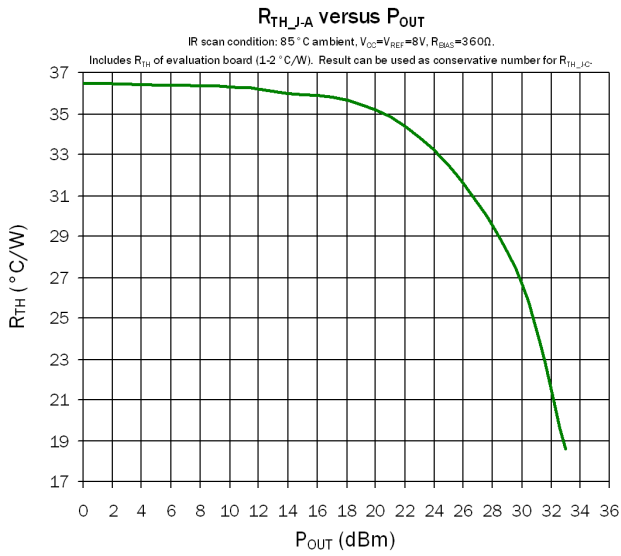

RoHS* Banned Material Content

RoHS Compliant: Yes
 Package total weight in grams (g): 0.08
 Compliance Date Code: N/A
 Bill of Materials Revision: B
 Pb Free Category: e3

Bill of Materials	Parts Per Million (PPM)					
	Pb	Cd	Hg	Cr VI	PBB	PBDE
Die	0	0	0	0	0	0
Molding Compound	0	0	0	0	0	0
Lead Frame	0	0	0	0	0	0
Die Attach Epoxy	0	0	0	0	0	0
Wire	0	0	0	0	0	0
Solder Plating	0	0	0	0	0	0

This RoHS banned material content declaration was prepared solely on information, including analytical data, provided to RFMD by its suppliers, and applies to the Bill of Materials (BOM) revision noted above.

* DIRECTIVE 2002/95/EC OF THE EUROPEAN PARLIAMENT AND OF THE COUNCIL of 27 January 2003 on the restriction of the use of certain hazardous substances in electrical and electronic equipment

