

RoHS Compliant & Pb-Free Product  
Package Style: CJ2BAT0

**Features**

- DC to 3.0GHz Operation
- Internally Matched Input and Output
- 15 dB Small Signal Gain
- 4.9dB Noise Figure
- +47 dBm Output IP<sub>3</sub>
- Single 9V to 12V Power Supply

**Applications**

- CATV Distribution Amplifiers
- Cable Modems
- Broadband Gain Blocks
- Laser Diode Driver
- Return Channel Amplifier
- Base Stations

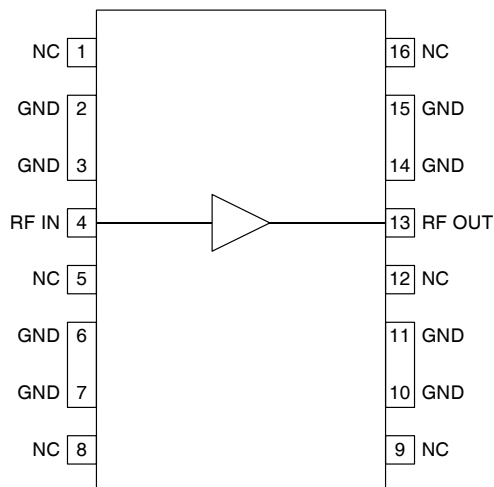

Functional Block Diagram

**Product Description**

The RF2317 is a general purpose, low-cost high-linearity RF amplifier IC. The device is manufactured on an advanced Gallium Arsenide Heterojunction Bipolar Transistor (HBT) process, and has been designed for use as an easily cascadable 75Ω gain block. The gain flatness of better than ±0.5dB from 50MHz to 1000MHz, and the high linearity, make this part ideal for cable TV applications. Other applications include IF and RF amplification in wireless voice and data communication products operating in frequency bands up to 3GHz. The device is self-contained with 75Ω input and output impedances and requires only two external DC biasing elements to operate as specified.

**Ordering Information**

RF2317	Linear CATV Amplifier
RF2317 PCBA	Fully Assembled Evaluation Board - 50Ω
RF2317 PCBA	Fully Assembled Evaluation Board - 75Ω

**Optimum Technology Matching® Applied**

- |  |                                      |                                     |                                   |
|--|--------------------------------------|-------------------------------------|-----------------------------------|
| <input checked="" type="checkbox"/> GaAs HBT | <input type="checkbox"/> SiGe BiCMOS | <input type="checkbox"/> GaAs pHEMT | <input type="checkbox"/> GaN HEMT |
| <input type="checkbox"/> GaAs MESFET         | <input type="checkbox"/> Si BiCMOS   | <input type="checkbox"/> Si CMOS    |                                   |
| <input type="checkbox"/> InGaP HBT           | <input type="checkbox"/> SiGe HBT    | <input type="checkbox"/> Si BJT     |                                   |

RF MICRO DEVICES®, RFMD®, Optimum Technology Matching®, Enabling Wireless Connectivity™, PowerStar®, POLARIS™ TOTAL RADIO™ and UltimateBlue™ are trademarks of RFMD, LLC. BLUETOOTH is a trademark owned by Bluetooth SIG, Inc., U.S.A. and licensed for use by RFMD. All other trade names, trademarks and registered trademarks are the property of their respective owners. ©2006, RF Micro Devices, Inc.

## Absolute Maximum Ratings

Parameter	Rating	Unit
Device Current	250	mA
Input RF Power	+18	dBm
Output Load VSWR	20:1	
Ambient Operating Temperature	-40 to +85	°C
Storage Temperature	-40 to +150	°C



**Caution!** ESD sensitive device.

Exceeding any one or a combination of the Absolute Maximum Rating conditions may cause permanent damage to the device. Extended application of Absolute Maximum Rating conditions to the device may reduce device reliability. Specified typical performance or functional operation of the device under Absolute Maximum Rating conditions is not implied.

RoHS status based on EU Directive 2002/95/EC (at time of this document revision).

The information in this publication is believed to be accurate and reliable. However, no responsibility is assumed by RF Micro Devices, Inc. ("RFMD") for its use, nor for any infringement of patents, or other rights of third parties, resulting from its use. No license is granted by implication or otherwise under any patent or patent rights of RFMD. RFMD reserves the right to change component circuitry, recommended application circuitry and specifications at any time without prior notice.

Parameter	Specification			Unit	Condition
	Min.	Typ.	Max.		
<b>Overall (50Ω)</b>					T = +25 °C, I <sub>CC</sub> = 180 mA, R <sub>C</sub> = 10.2Ω, 50Ω System
Frequency Range	DC		3000	MHz	3dB Bandwidth
Gain	13.5	14.3	15.0	dB	
Noise Figure		4.9		dB	From 100 MHz to 1000 MHz
Input VSWR		1.7:1			Appropriate values for the DC blocking capacitors and bias inductor are required to maintain this VSWR at the intended operating frequency range.
Output VSWR		2.3:1			Appropriate values for the DC blocking capacitors and bias inductor are required to maintain this VSWR at the intended operating frequency range.
Output IP <sub>3</sub>		+47		dBm	At 100 MHz
	+37	+42		dBm	At 500 MHz
		+37		dBm	At 900 MHz
Output IP <sub>2</sub>		+55		dBm	F <sub>1</sub> = 400 MHz, F <sub>2</sub> = 500 MHz, F <sub>OUT</sub> = 100 MHz
Output P <sub>1dB</sub>		+25.5		dBm	At 100 MHz
		+24		dBm	At 500 MHz
		+22		dBm	At 900 MHz
Reverse Isolation		19.5		dB	
<b>Thermal</b>					
Theta <sub>JC</sub>		55		°C/W	I <sub>CC</sub> = 150 mA, P <sub>DISS</sub> = 1.2 W, T <sub>AMB</sub> = 85 °C
Maximum Junction Temperature		150		°C	
Mean Time To Failures		3100		years	T <sub>AMB</sub> = +85 °C
Theta <sub>JC</sub>		58		°C/W	I <sub>CC</sub> = 180 mA, P <sub>DISS</sub> = 1.5 W, T <sub>AMB</sub> = 85 °C
Maximum Junction Temperature		175		°C	
Mean Time To Failures		380		years	T <sub>AMB</sub> = +85 °C
<b>Power Supply (50Ω)</b>					
Device Voltage		8.5		V	On pin 13, I <sub>CC</sub> = 150 mA
		9.3		V	On pin 13, I <sub>CC</sub> = 180 mA
Operating Current Range	100	180	200	mA	Actual current determined by V <sub>CC</sub> and R <sub>C</sub>

Parameter	Specification			Unit	Condition
	Min.	Typ.	Max.		
<b>Overall (75Ω)</b>					T = 25 °C, I <sub>CC</sub> = 180 mA, R <sub>C</sub> = 14.3Ω, 75Ω System
Frequency Range	DC		3000	MHz	3 dB Bandwidth
Gain		15.0		dB	
Noise Figure		4.8		dB	From 100 MHz to 1000 MHz
Input VSWR		1.3:1			Appropriate values for the DC blocking capacitors and bias inductor are required to maintain this VSWR at the intended operating frequency range.
Output VSWR		1.8:1			Appropriate values for the DC blocking capacitors and bias inductor are required to maintain this VSWR at the intended operating frequency range.
Output IP <sub>3</sub>		+49		dBm	At 100 MHz
	+37	+43		dBm	At 500 MHz
		+38		dBm	At 900 MHz
Output IP <sub>2</sub>		+58		dBm	F <sub>1</sub> = 400 MHz, F <sub>2</sub> = 500 MHz, F <sub>OUT</sub> = 100 MHz
Output P <sub>1dB</sub>		+22		dBm	At 100 MHz
		+22		dBm	At 500 MHz
		+21		dBm	At 900 MHz
Reverse Isolation		19		dB	
<b>133 Channels</b>					10 dBmV per channel, flat, at the input of the amplifier; I <sub>CC</sub> = 150 mA, V <sub>CC</sub> = 10.4 V
XMOD		< -75		dBc	At 55.25 MHz
		< -75		dBc	At 331.25 MHz
		< -75		dBc	At 547.25 MHz
		< -75		dBc	At 853.25 MHz
CTB		-85		dBc	At 55.25 MHz
		-85		dBc	At 331.25 MHz
		-84		dBc	At 547.25 MHz
		-83		dBc	At 853.25 MHz
CSO + 1.25 MHz		-90		dBc	At 55.25 MHz
		-72		dBc	At 331.25 MHz
		-69		dBc	At 853.25 MHz
		-64		dBc	At 547.25 MHz
CSO - 1.25 MHz		-63		dBc	At 55.25 MHz
		-65		dBc	At 331.25 MHz
		-70		dBc	At 547.25 MHz
		-90		dBc	At 853.25 MHz

Parameter	Specification			Unit	Condition
	Min.	Typ.	Max.		
<b>133 Channels</b>					10 dBmV per channel, flat, at the input of the amplifier; $I_{CC} = 180\text{mA}$ , $V_{CC} = 11.4\text{V}$
XMOD		< -75		dBc	At 55.25 MHz
		< -75		dBc	At 331.25 MHz
		< -75		dBc	At 547.25 MHz
		< -75		dBc	At 853.25 MHz
CTB		-89		dBc	At 55.25 MHz
		-86		dBc	At 331.25 MHz
		-86		dBc	At 547.25 MHz
		-84		dBc	At 853.25 MHz
CSO + 1.25 MHz		-89		dBc	At 55.25 MHz
		-74		dBc	At 331.25 MHz
		-69		dBc	At 853.25 MHz
		-62		dBc	At 547.25 MHz
CSO - 1.25 MHz		-63		dBc	At 55.25 MHz
		-65		dBc	At 331.25 MHz
		-71		dBc	At 547.25 MHz
		-91		dBc	At 853.25 MHz
<b>Power Supply (75Ω)</b>					
Device Voltage		8.3		V	On pin 13, $I_{CC} = 150\text{mA}$
		8.9		V	On pin 13, $I_{CC} = 180\text{mA}$
Operating Current Range	100	180	200	mA	Actual current determined by $V_{CC}$ and $R_C$

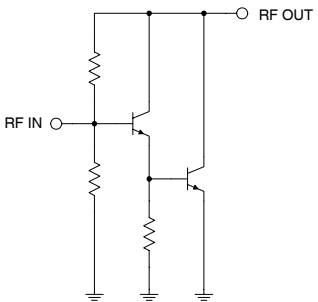
Pin	Function	Description	Interface Schematic
1	NC	This pin is internally not connected.	
2	GND	Ground connection. Keep traces physically short and connect immediately to ground plane for best performance. Each ground pin should have a via to the ground plane.	
3	GND	Same as pin 2.	
4	RF IN	RF input pin. This pin is NOT internally DC blocked. A DC blocking capacitor, suitable for the frequency of operation, should be used in most applications. DC coupling of the input is not allowed, because this will override the internal feedback loop and cause temperature instability.	
5	NC	This pin is internally not connected.	
6	GND	Same as pin 2.	
7	GND	Same as pin 2.	
8	NC	This pin is internally not connected.	
9	NC	This pin is internally not connected.	
10	GND	Same as pin 2.	
11	GND	Same as pin 2.	
12	NC	This pin is internally not connected.	
13	RF OUT	RF output and bias pin. Because DC is present on this pin, a DC blocking capacitor, suitable for the frequency of operation, should be used in most applications. For biasing, an RF choke in series with a resistor is needed. The DC voltage on this pin is typically 8.3V with a current of 150 mA (for 75Ω board). See device voltage versus device current plot. In lower power applications the value of $R_C$ can be increased to lower the current and $V_D$ on this pin.	
14	GND	Same as pin 2.	
15	GND	Same as pin 2.	
16	NC	This pin is internally not connected.	

**Package Drawing**

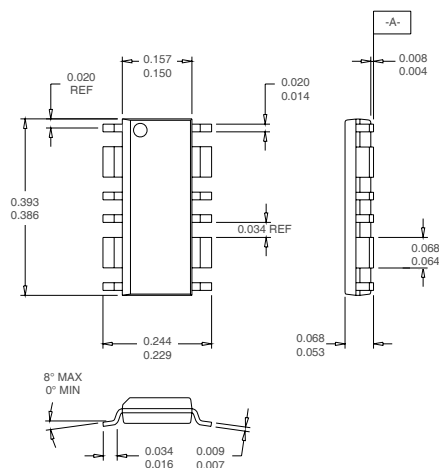

## Application Schematic 5MHz to 50MHz Reverse Path

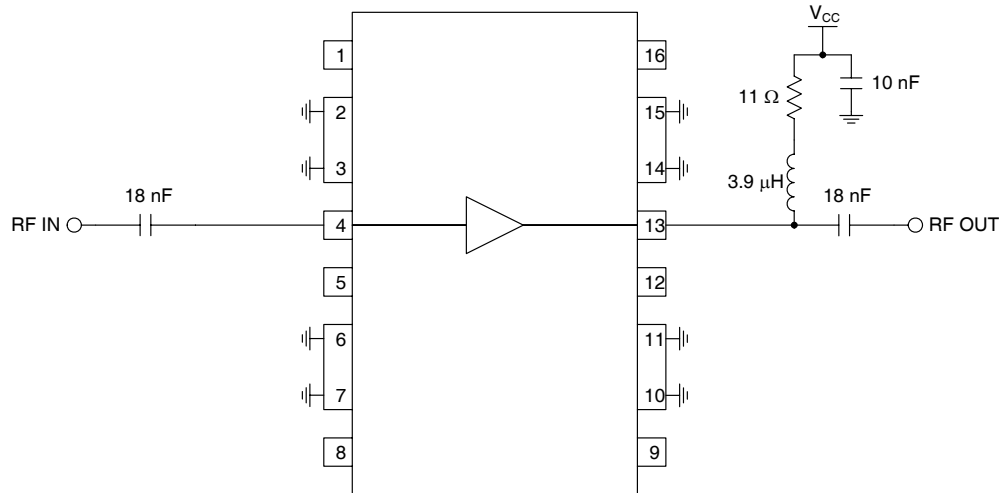

NOTES:  
Gain Flatness <0.5 dB  
Input and Output Return Loss >20 dB in 75 Ω system

## Evaluation Board Schematic - 50Ω (Download [Bill of Materials](http://www.rfmd.com) from [www.rfmd.com](http://www.rfmd.com).)

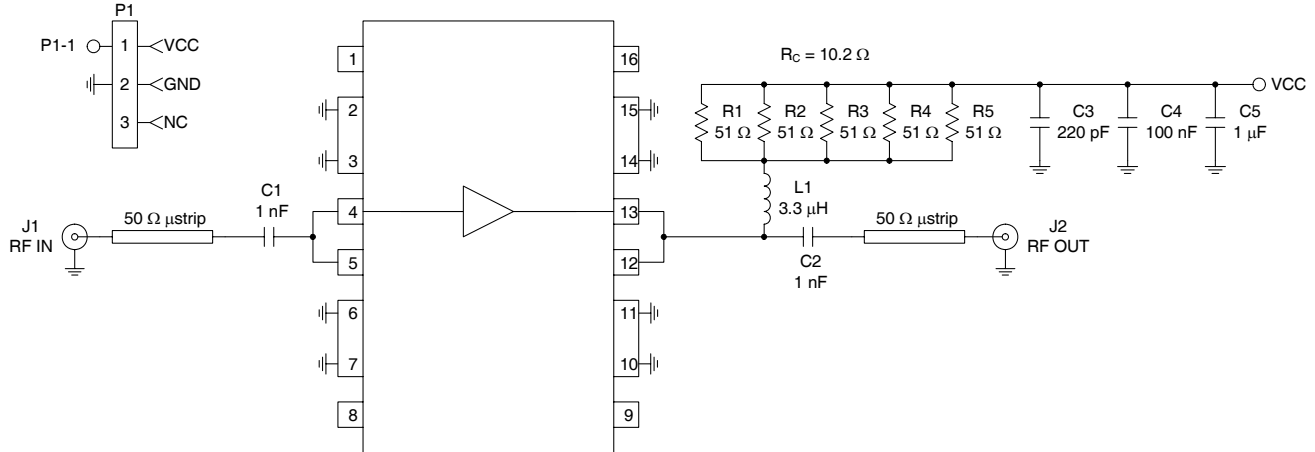

2317400 Rev -

Evaluation Board Schematic - 75Ω

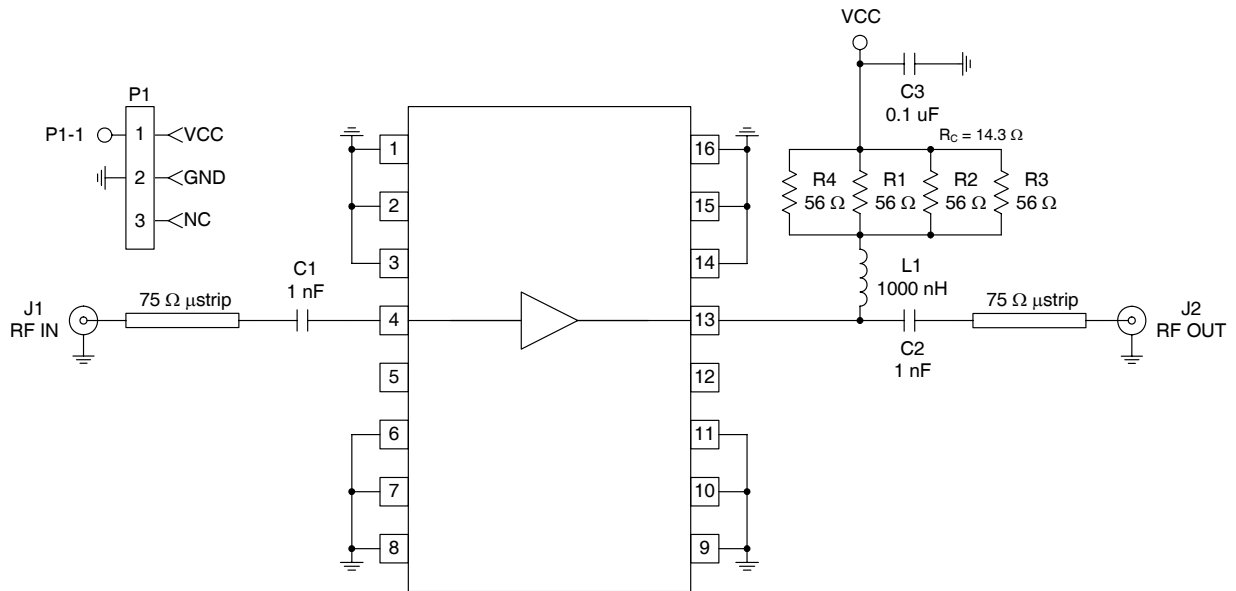

2317401 Rev -

**Evaluation Board Layout - 50Ω**  
**2.0" x 2.0"**  
**Board Thickness 0.031", Board Material FR-4**

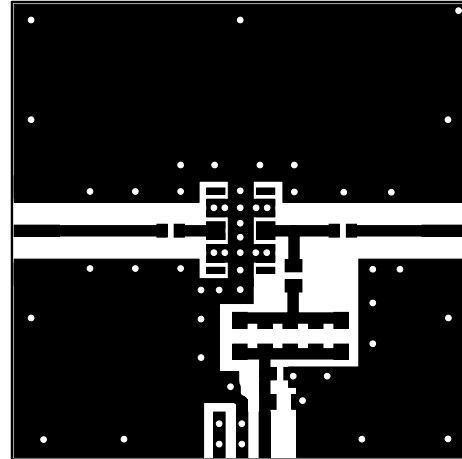
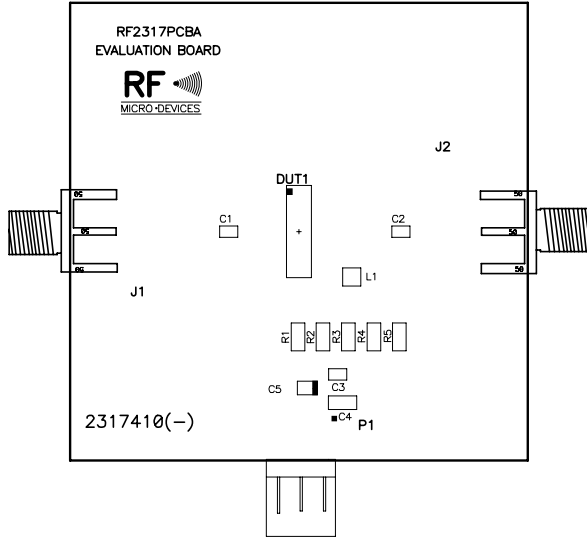

**Evaluation Board Layout - 75Ω**  
**1.40" x 1.40"**  
**Board Thickness 0.062", Board Material FR-4**

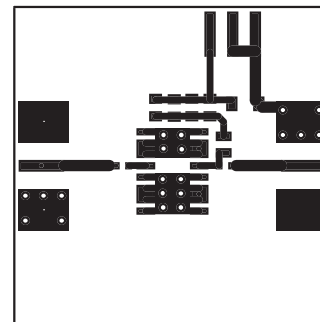
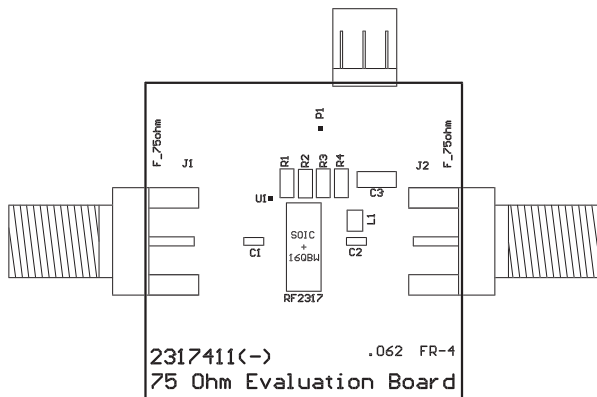



**75Ω, I<sub>CC</sub> = 150mA, Temp = +25°C**

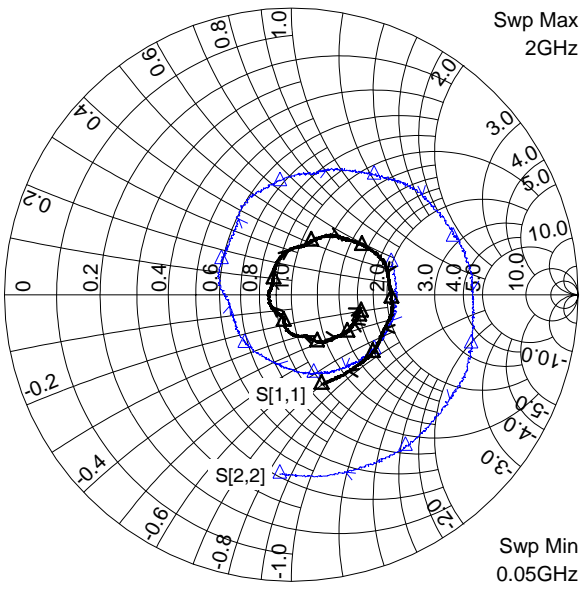

**75Ω, I<sub>CC</sub> = 180mA, Temp = +25°C**

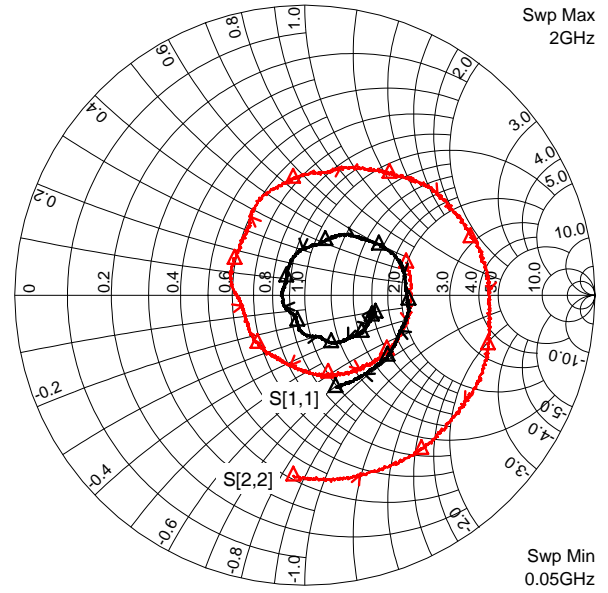

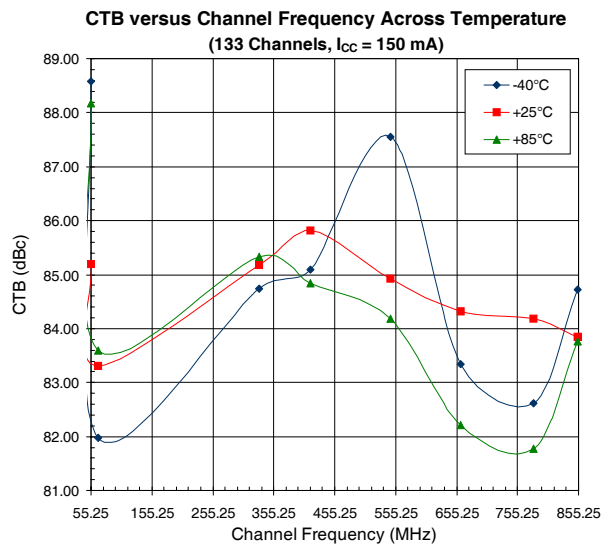
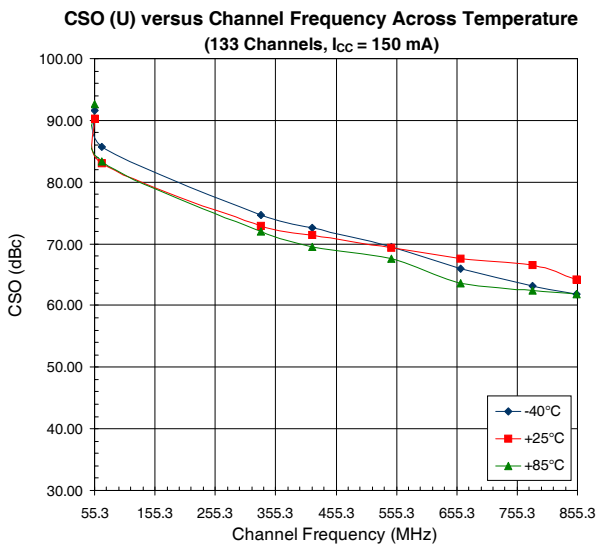
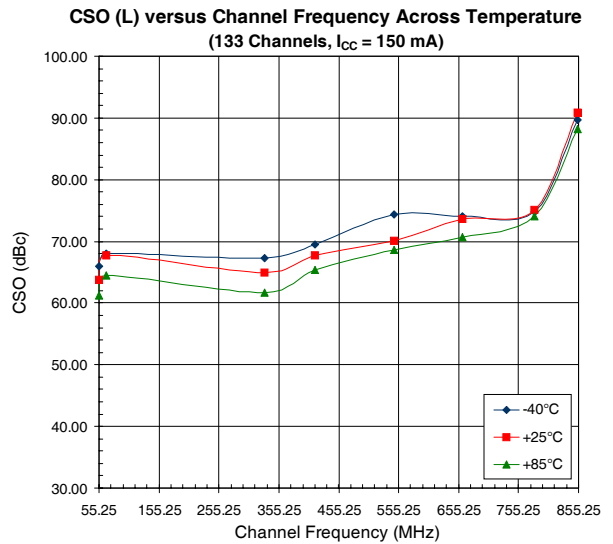
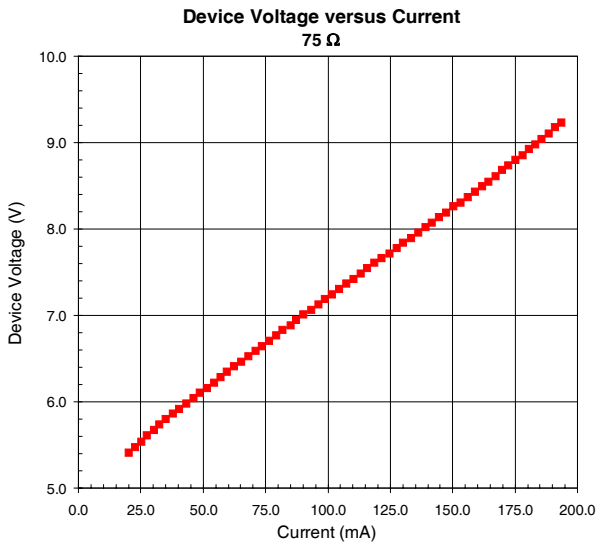
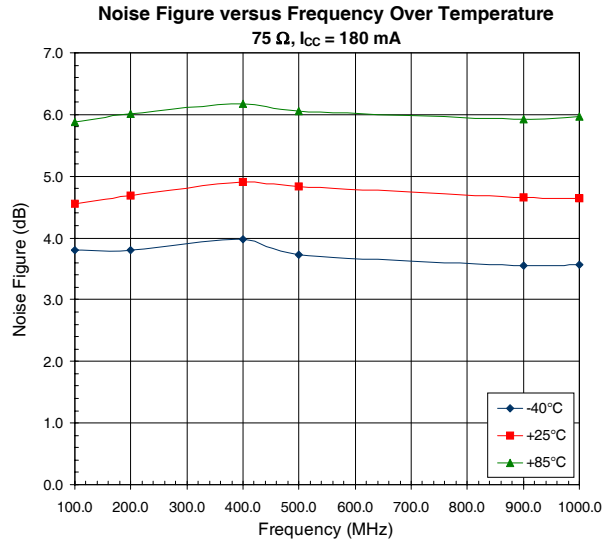
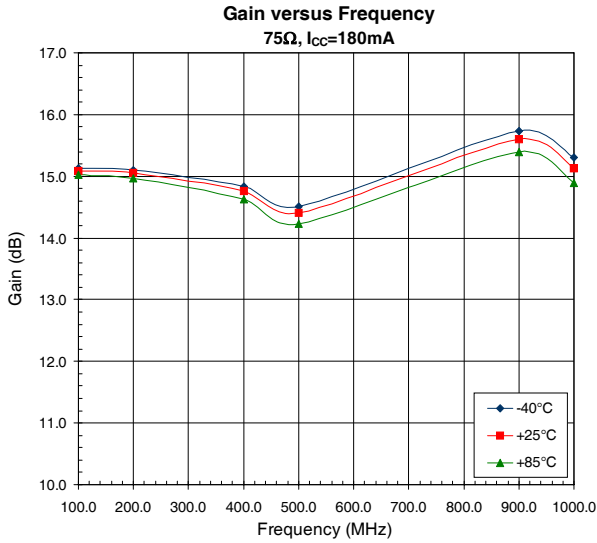

**CSO (L) versus Channel Frequency Across Temperature**  
(133 Channels,  $I_{CC} = 180 \text{ mA}$ )

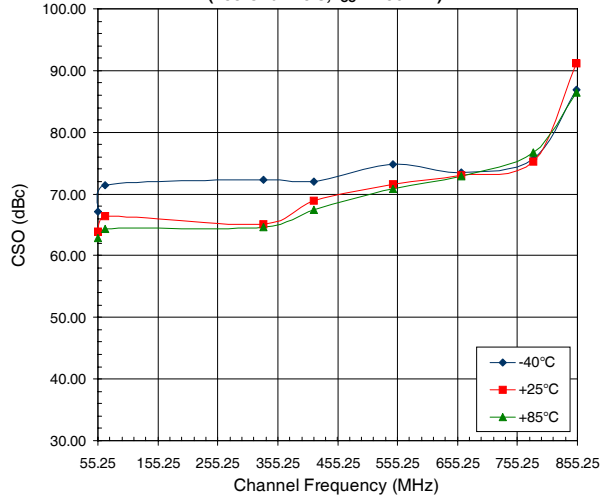

**CSO (U) versus Channel Frequency Across Temperature**  
(133 Channels,  $I_{CC} = 180 \text{ mA}$ )

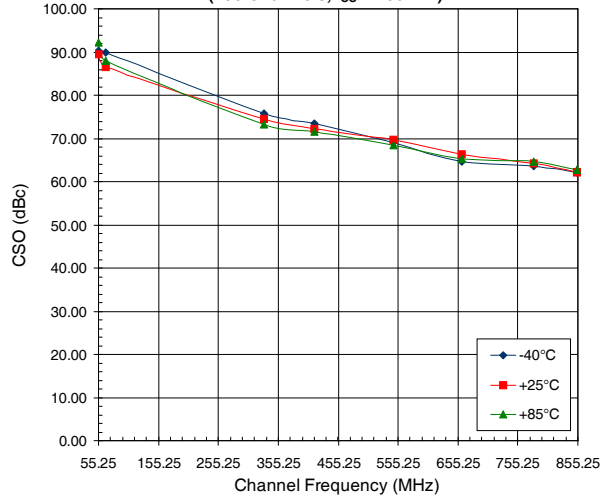

**CTB versus Channel Frequency Across Temperature**  
(133 Channels,  $I_{CC} = 180 \text{ mA}$ )

