

DATA SHEET

SKY65009-70LF: 250–2500 MHz Linear Power Amplifier Driver

Applications

- UHF television, CATV, DBS
- TETRA radio
- GSM, GPRS, CDMA, WCDMA
- AMPS, PCS, DCS, PCS
- ISM band transmitters
- Fixed WCS
- WLAN, WiMAX
- RFID

Features

- Wideband frequency operation: 250–2500 MHz
- High linearity: OIP3 > 40 dBm
- Output P_{1 dB} > 25 dBm
- High efficiency: PAE 40%
- Single DC supply: 3.3 V or 5 V
- On-chip bias circuit
- Low power consumption
- SOT-89 (4-pin 2.4 x 4.5 mm) lead (Pb)-free, RoHS-compliant and Green™ package (MSL-1 @ 260 °C per JEDEC J-STD-020)

Description

Skyworks SKY65009-70LF is a high-performance, ultrawideband Power Amplifier (PA) driver with superior output power, noise figure, linearity, and efficiency. The high linearity and superior Adjacent Channel Power Rejection/Adjacent Channel Leakage Ratio (ACPR/ACLR) performance make the SKY65009-70LF ideal for use in the driver stage of infrastructure transmit chains.

The SKY65009-70LF is fabricated using Skyworks high reliability Aluminum (Al) Gallium Arsenide (GaAs) Heterojunction Bipolar Transistor (HBT) process, which allows for single supply operation while maintaining high efficiency and good linearity. The SKY65009-70LF uses a lead (Pb)-free, RoHS-compliant, SOT-89 industry standard package.

The module can operate over the temperature range of -40 °C to +85 °C. A populated evaluation board is available upon request.

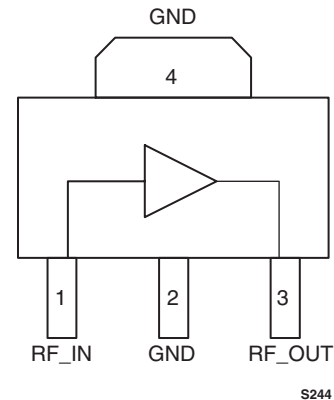

Functional Block Diagram

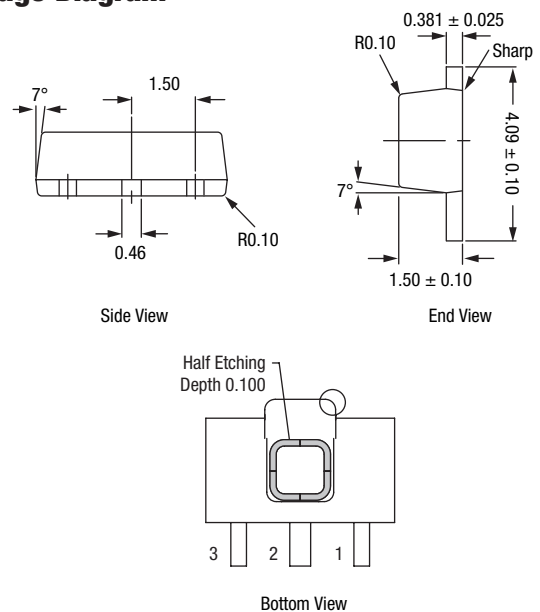

Package Diagram



NEW Skyworks Green™ products are RoHS (Restriction of Hazardous Substances)-compliant, conform to the EIA/EICTA/JEITA Joint Industry Guide (JIG) Level A guidelines, are halogen free according to IEC-61249-2-21, and contain <1,000 ppm antimony trioxide in polymeric materials.

Electrical Characteristics

V_{CC} = 5 V, Z₀ = 50 Ω, T_C = 25 °C, unless otherwise noted

Parameter	Symbol	Condition	Min.	Typ.	Max.	Unit
Test Frequency = 450 MHz						
Frequency	F			450		MHz
Quiescent current	I _{CCQ}	No RF		100		mA
Small signal gain	S ₂₁	P _{IN} = -15 dBm		22		dB
Input return loss	S ₁₁	Small signal		14.5		dB
Output return loss	S ₂₂	Small signal		11.5		dB
Output power at 1 dB compression	P _{1 dB}	CW		26.8		dBm
PAE at output P _{1 dB}	PAE	CW		38.5		%
Output 3rd order intercept point	OIP3	P _{IN} /tone = -5 dBm, ΔF=1 MHz		35		dBm
Noise figure	NF	P _{IN} = -15 dBm		6.5		dB
Test Frequency = 900 MHz						
Frequency	F			900		MHz
Quiescent current	I _{CCQ}	No RF		100		mA
Small signal gain	S ₂₁	P _{IN} = -15 dBm		17		dB
Input return loss	S ₁₁	Small signal		9		dB
Output return loss	S ₂₂	Small signal		7.5		dB
Output power at 1 dB compression	P _{1 dB}	CW		25		dBm
PAE at output P _{1 dB}	PAE	CW		33		%
Output 3rd order intercept point	OIP3	P _{IN} /tone = -2 dBm, ΔF = 1 MHz		41		dBm
Power out @ ACPR = -45 dBc	ACPR	IS-95, 750 kHz offset		19		dBm
Noise figure	NF	P _{IN} = -15 dBm		5		dB
Test Frequency = 1960 MHz						
Frequency	F	Best OIP3 match		1960		MHz
Quiescent current	I _{CCQ}	No RF		100	130	mA
Small signal gain	S ₂₁	P _{IN} = -15 dBm	10.5	12		dB
Input return loss	S ₁₁	Small signal		19		dB
Output return loss	S ₂₂	Small signal		10.5		dB
Output power at 1 dB compression	P _{1 dB}	CW	26	27		dBm
PAE at output P _{1 dB}	PAE	CW	40	47		%
Output 3rd order intercept point	OIP3	P _{IN} /tone = -1 dBm, ΔF = 1 MHz	37	42		dBm
Power out @ ACPR = -45 dBc	ACPR	IS-95, 885 kHz offset	18	20		dBm
Noise figure	NF	P _{IN} = -15 dBm		4.3	5.5	dB

Electrical Characteristics

$V_{CC} = 5\text{ V}$, $Z_0 = 50\ \Omega$, $T_C = 25\ ^\circ\text{C}$, unless otherwise noted

Parameter	Symbol	Condition	Min.	Typ.	Max.	Unit
Test Frequency = 2140 MHz						
Frequency	F			2140		MHz
Quiescent current	I_{CCQ}	$P_{IN} = -15\text{ dBm}$		100		mA
Small signal gain	$ S_{21} $	Small signal		11.5		dB
Input return loss	$ S_{11} $	Small signal		20		dB
Output return loss	$ S_{22} $	Small signal		9.5		dB
Output power at 1 dB compression	$P_{1\text{ dB}}$	CW		26.7		dBm
PAE at output $P_{1\text{ dB}}$	PAE	CW		48		%
Output 3rd order intercept point	OIP3	$P_{IN}/\text{tone} = 0\text{ dBm}$, $\Delta F = 1\text{ MHz}$		42.5		dBm
Power out @ ACLR = -45 dBc	ACLR	3G WCDMA; downlink 64 DPCH, 5 MHz offset		18		dBm
Noise figure	NF	$P_{IN} = -15\text{ dBm}$		3.8		dB
Test Frequency = 2450 MHz						
Frequency	F			2450		MHz
Quiescent current	I_{CCQ}	No RF		100		mA
Small signal gain	$ S_{21} $	$P_{IN} = -15\text{ dBm}$		10.3		dB
Input return loss	$ S_{11} $	Small signal		22		dB
Output return loss	$ S_{22} $	Small signal		15		dB
Output power at 1 dB compression	$P_{1\text{ dB}}$	CW		25.5		dBm
PAE at output $P_{1\text{ dB}}$	PAE	CW		38.7		%
Output 3rd order intercept point	OIP3	$P_{IN}/\text{tone} = 0\text{ dBm}$, $\Delta F = 1\text{ MHz}$		40		dBm
Noise figure	NF	$P_{IN} = -15\text{ dBm}$		4.1		dB

Absolute Maximum Ratings

Characteristic	Value
RF output power (P_{OUT})	26 dBm
Supply voltage (V_{CC})	6 V
Supply current (I_{CC})	300 mA
Power dissipation (P_{DISS})	1.1 W
Junction temperature (T_J)	150 $^\circ\text{C}$
Operating case temperature range (T_C)	-40 $^\circ\text{C}$ to +85 $^\circ\text{C}$
Storage temperature range (T_{ST})	-55 $^\circ\text{C}$ to +125 $^\circ\text{C}$

Performance is guaranteed only under the conditions listed in the specifications table and is not guaranteed under the full range(s) described by the Absolute Maximum specifications. Exceeding any of the absolute maximum/minimum specifications may result in permanent damage to the device and will void the warranty.

CAUTION: Although this device is designed to be as robust as possible, ESD (Electrostatic Discharge) can damage this device. This device must be protected at all times from ESD. Static charges may easily produce potentials of several kilovolts on the human body or equipment, which can discharge without detection. Industry-standard ESD precautions must be employed at all times.

Recommended Operating Conditions

Parameter	Symbol	Condition	Min.	Typ.	Max.	Unit
Supply voltage	V_{CC}			5	5.5	V
Operating frequency	F_0		100		2500	MHz
Operating case temperature	T_C		-40	25	85	°C
Thermal resistance	θ_{JC}	Junction to case		20		°C/W

Typical Performance Data

$V_{CC} = 5\text{ V}$, $Z_0 = 50\ \Omega$, $T_C = 25\ ^\circ\text{C}$, $F = 450\text{ MHz}$, unless otherwise noted

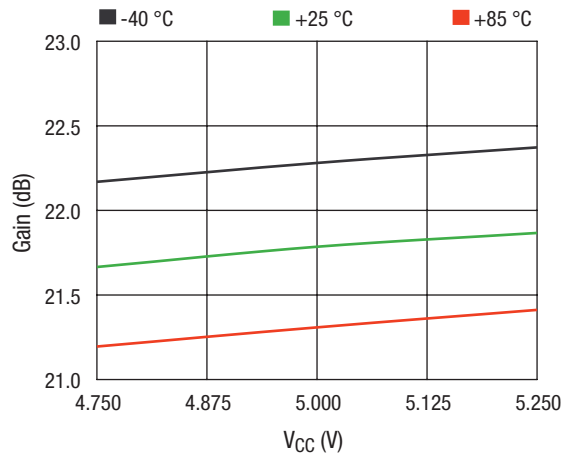

Gain vs. V_{CC} Across Temperature @ $P_{IN} -15\text{ dBm}$

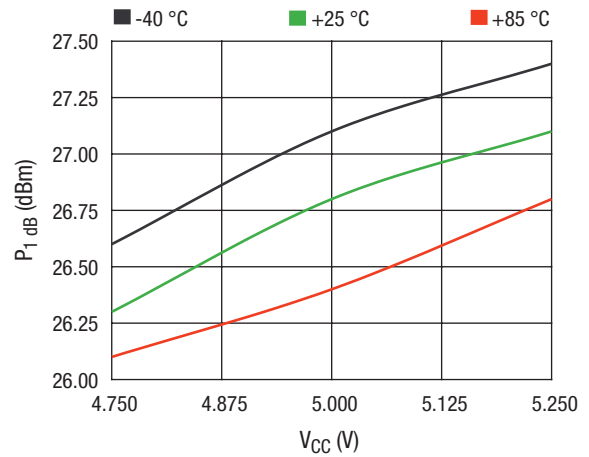

$P_1\text{ dB}$ vs. V_{CC} Across Temperature

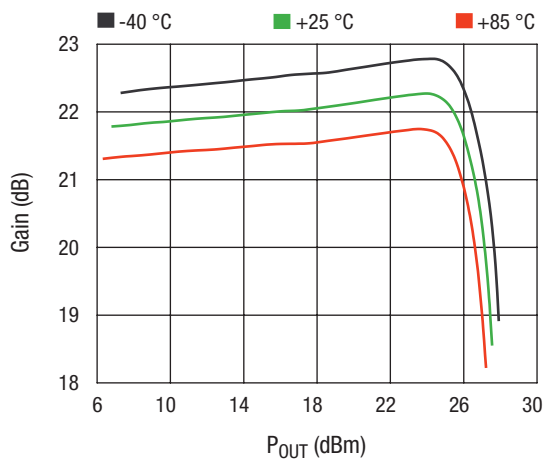

Gain vs. P_{OUT} Across Temperature

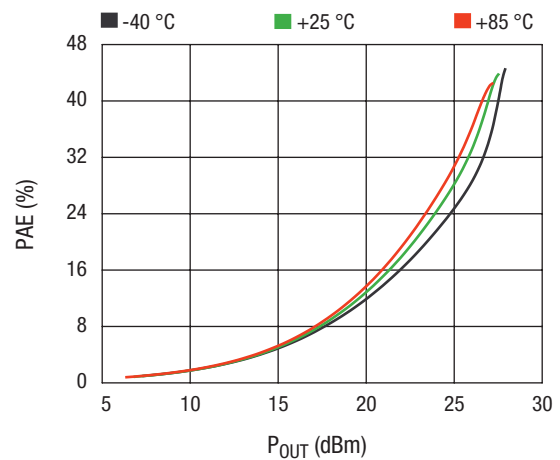

PAE vs. P_{OUT} Across Temperature

Typical Performance Data

$V_{CC} = 5\text{ V}$, $Z_0 = 50\ \Omega$, $T_C = 25\ ^\circ\text{C}$, $F = 450\text{ MHz}$, unless otherwise noted

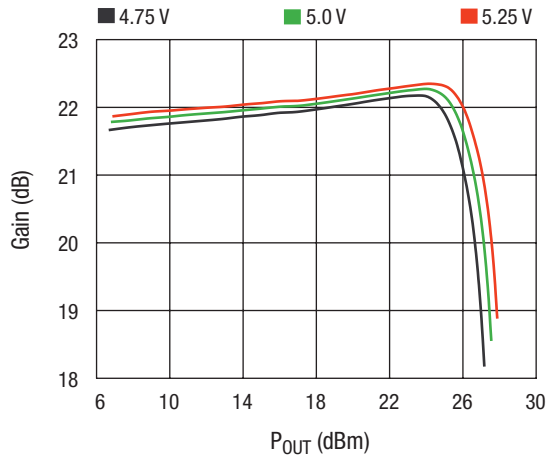

Gain vs. P_{OUT} Across Voltage

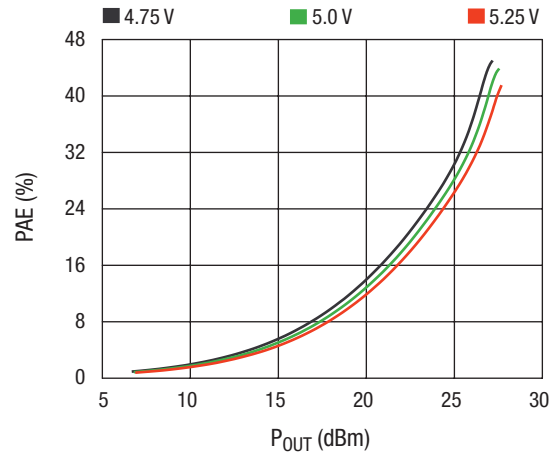

PAE vs. P_{OUT} Across Voltage

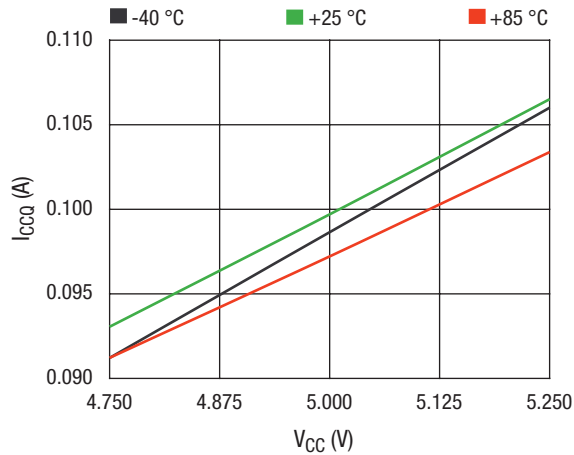

Quiescent Current vs. V_{CC} Across Temperature

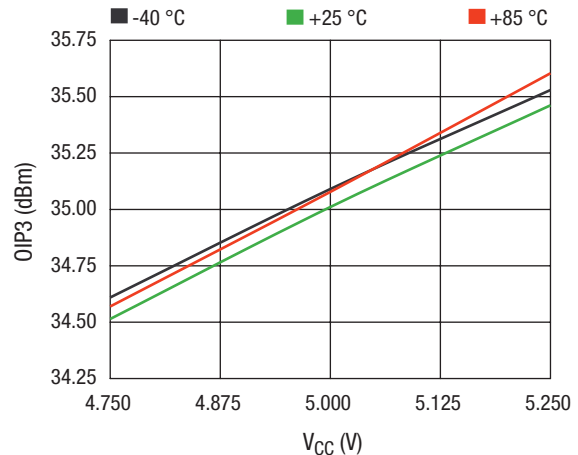

OIP3 vs. V_{CC} Across Temperature, P_{IN}/Tone = -5 dBm

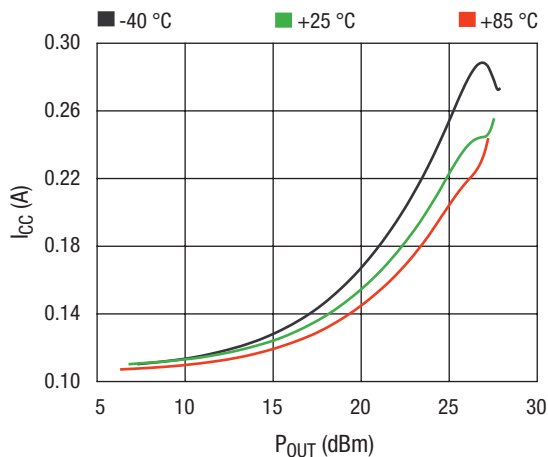

I_{CC} vs. P_{OUT} Across Temperature

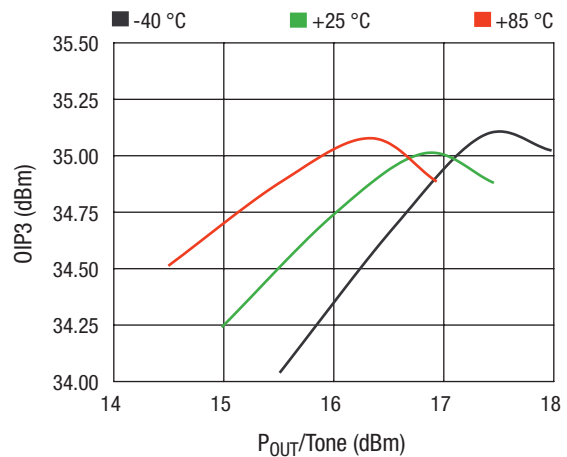

OIP3 vs. P_{OUT}/Tone Across Temperature

Typical Performance Data

$V_{CC} = 5\text{ V}$, $Z_0 = 50\ \Omega$, $T_C = 25\ ^\circ\text{C}$, $F = 450\ \text{MHz}$, unless otherwise noted

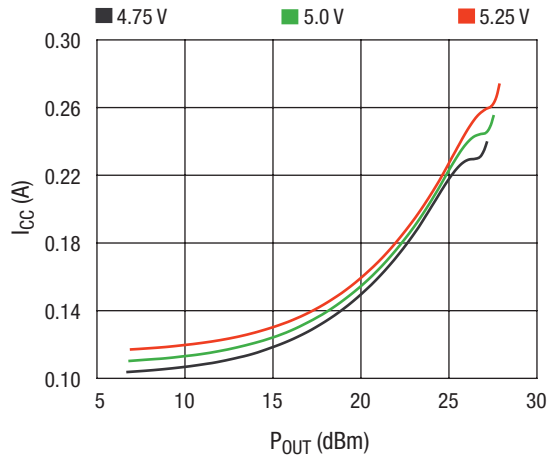

I_{CC} vs. P_{OUT} Across Voltage

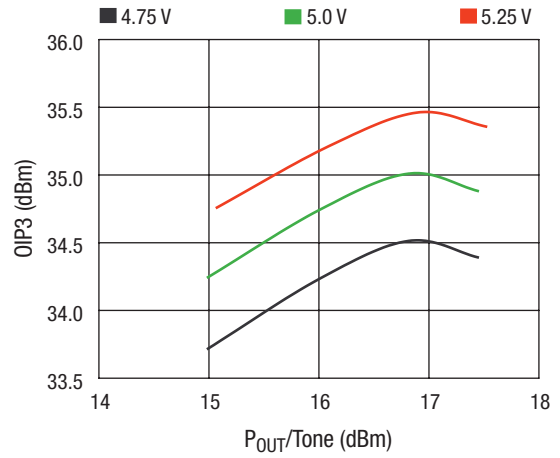

OIP3 vs. P_{OUT}/Tone Across Voltage

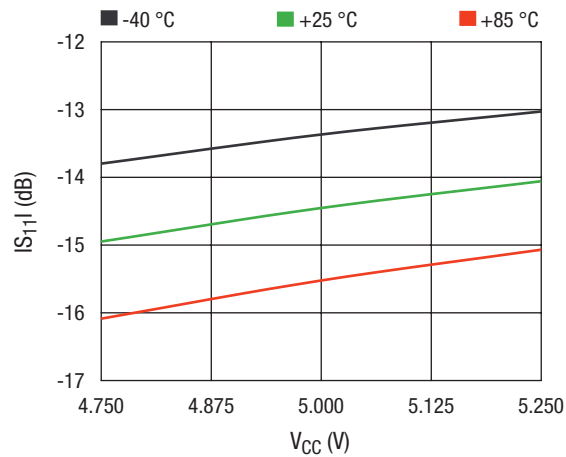

|S₁₁| vs. V_{CC} Across Temperature

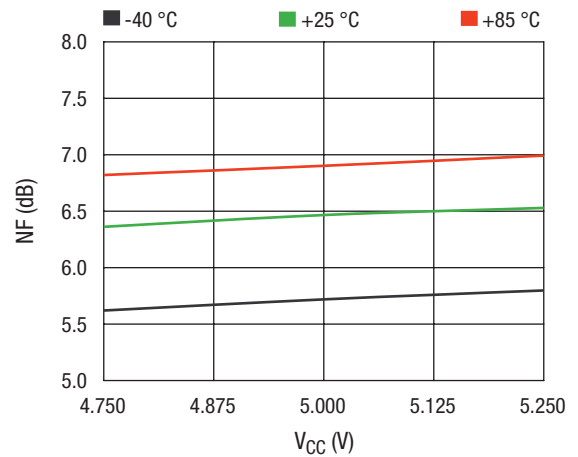

NF vs. V_{CC} Across Temperature

Typical Performance Data

$V_{CC} = 5\text{ V}$, $Z_0 = 50\ \Omega$, $T_C = 25\ ^\circ\text{C}$, $F = 900\text{ MHz}$, unless otherwise noted

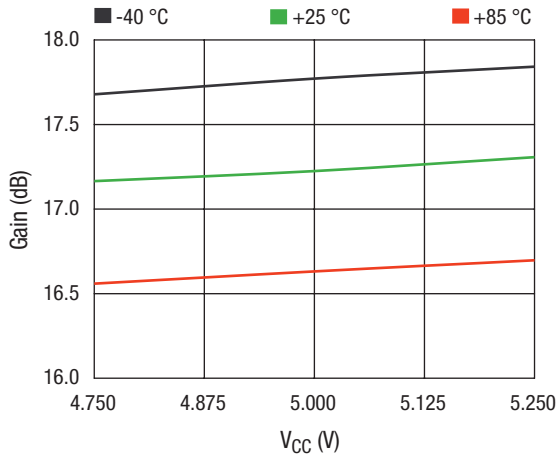

Gain vs. V_{CC} Across Temperature @ $P_{IN} -15\text{ dBm}$

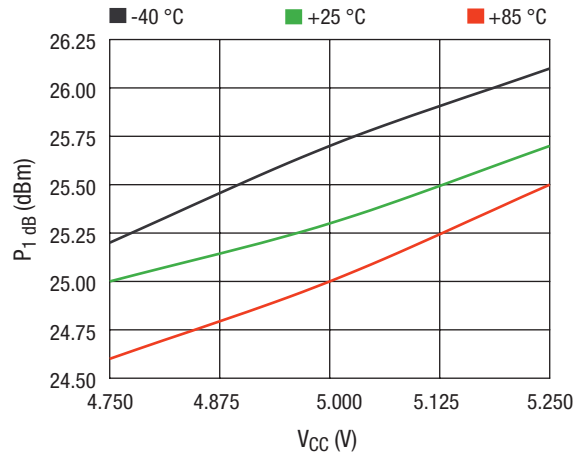

$P_1\text{ dB}$ vs. V_{CC} Across Temperature

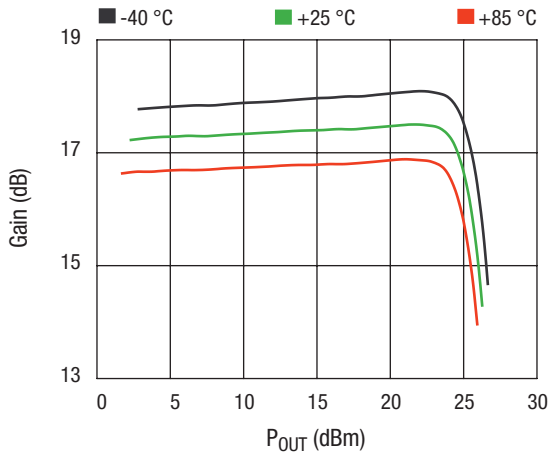

Gain vs. P_{OUT} Across Temperature

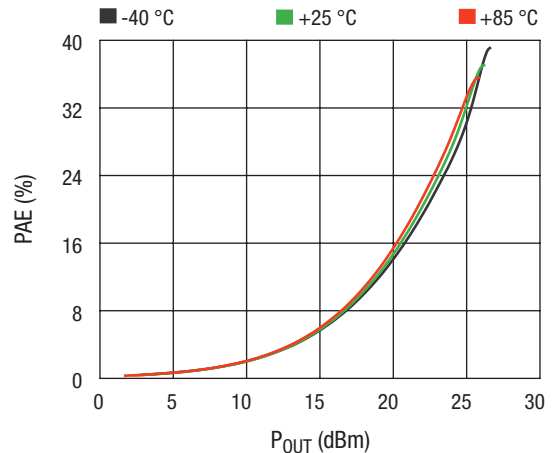

PAE vs. P_{OUT} Across Temperature

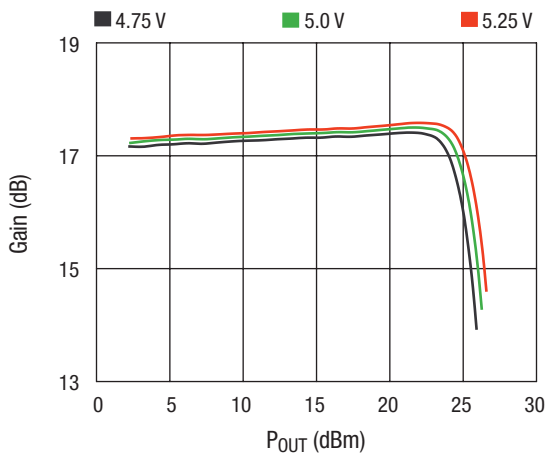

Gain vs. P_{OUT} Across V_{CC}

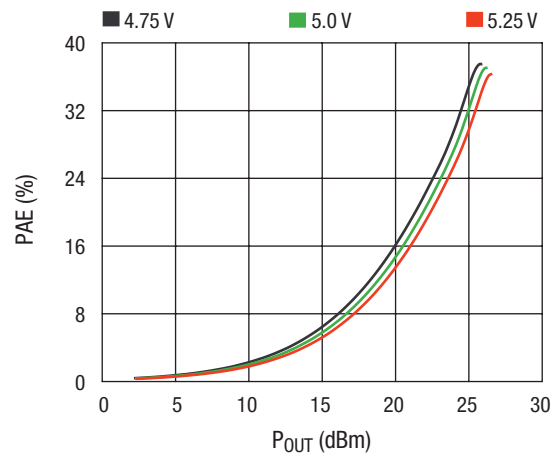

PAE vs. P_{OUT} Across V_{CC}

Typical Performance Data

$V_{CC} = 5\text{ V}$, $Z_0 = 50\ \Omega$, $T_C = 25\ ^\circ\text{C}$, $F = 900\text{ MHz}$, unless otherwise noted

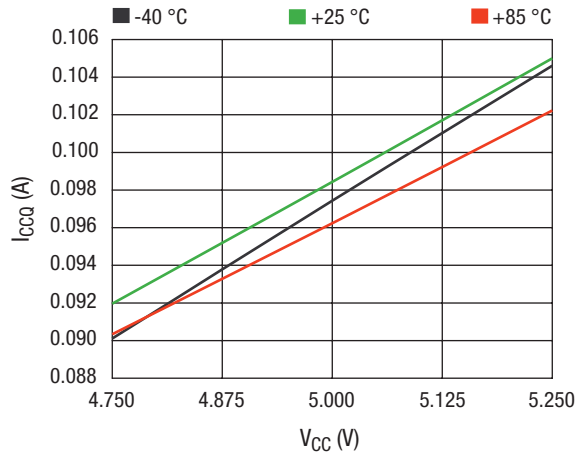

Quiescent Current vs. V_{CC} Across Temperature

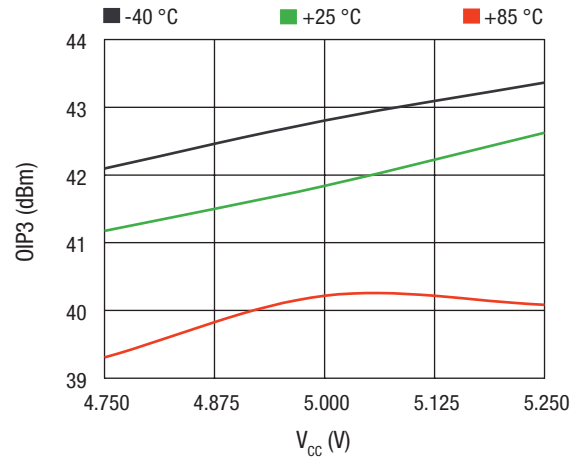

OIP3 vs. V_{CC} Across Temperature, $P_{IN}/\text{Tone} = -2\text{ dBm}$

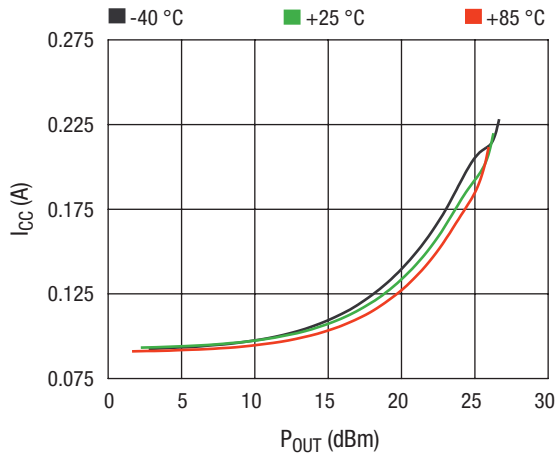

I_{CC} vs. P_{OUT} Across Temperature

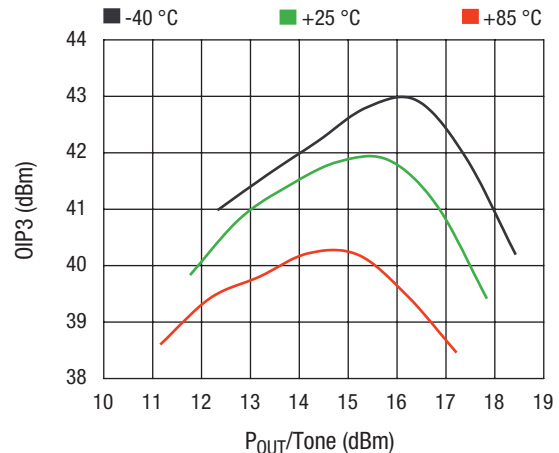

OIP3 vs. P_{OUT}/Tone Across Temperature

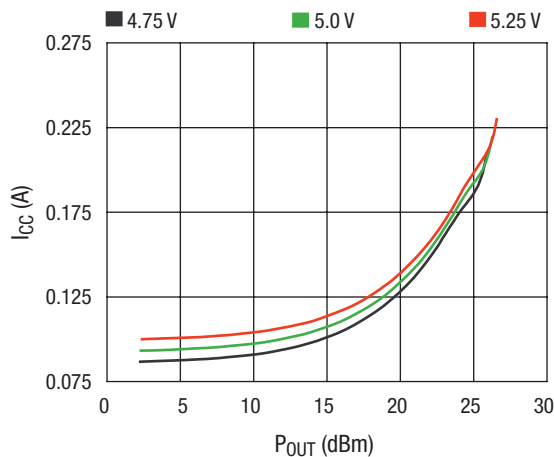

I_{CC} vs. P_{OUT} Across V_{CC}

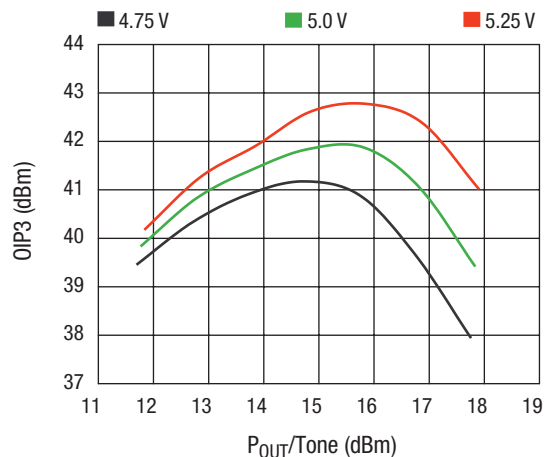

OIP3 vs. P_{OUT}/Tone Across V_{CC}

Typical Performance Data

$V_{CC} = 5\text{ V}$, $Z_0 = 50\ \Omega$, $T_C = 25\ ^\circ\text{C}$, $F = 900\ \text{MHz}$, unless otherwise noted

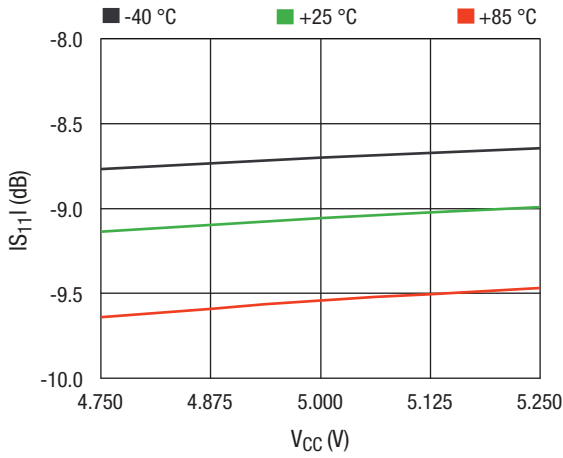

|S₁₁| vs. V_{CC} Across Temperature

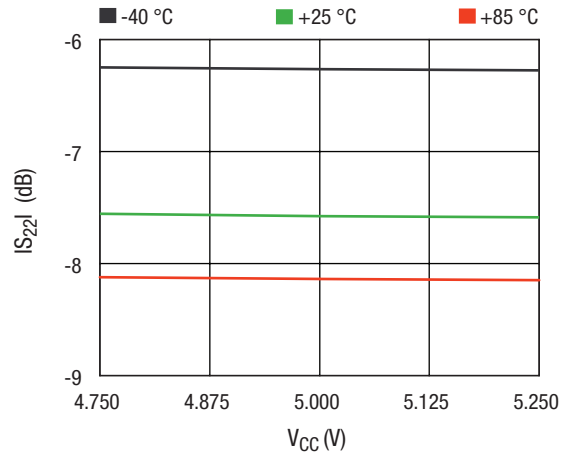

|S₂₂| vs. V_{CC} Across Temperature

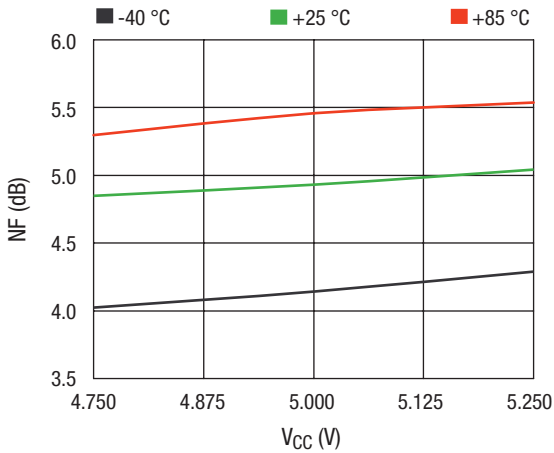

NF vs. V_{CC} Across Temperature

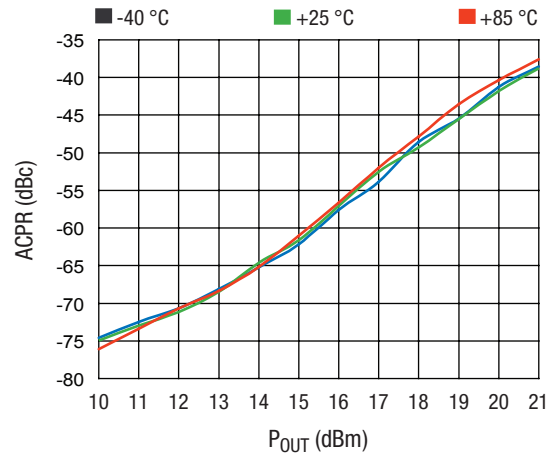

ACPR vs. P_{OUT} Across Temperature

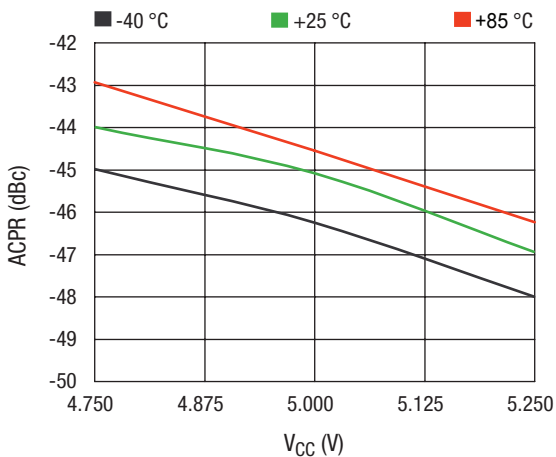

ACPR vs. V_{CC} Across Temperature @ P_{OUT} = 19 dBm

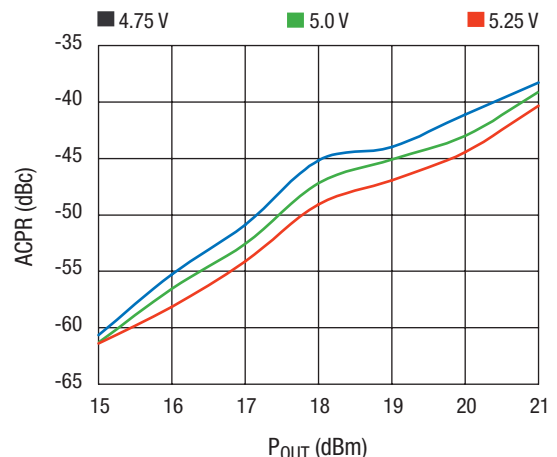

ACPR vs. P_{OUT} Across V_{CC}

Typical Performance Data

$V_{CC} = 5\text{ V}$, $Z_0 = 50\ \Omega$, $T_C = 25\ ^\circ\text{C}$, $F = 1960\ \text{MHz}$ (best OIP3 match), unless otherwise noted

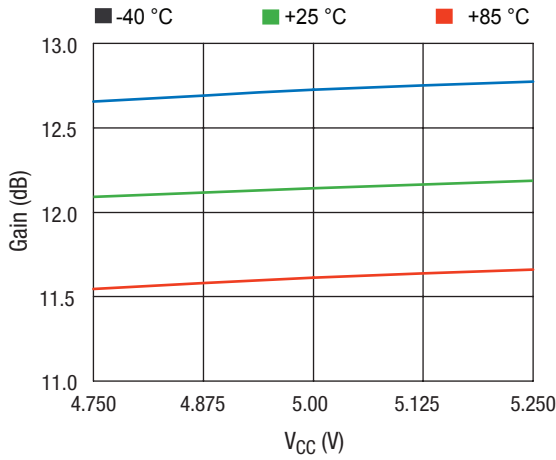

Gain vs. V_{CC} Across Temperature @ $P_{IN} -15\ \text{dBm}$

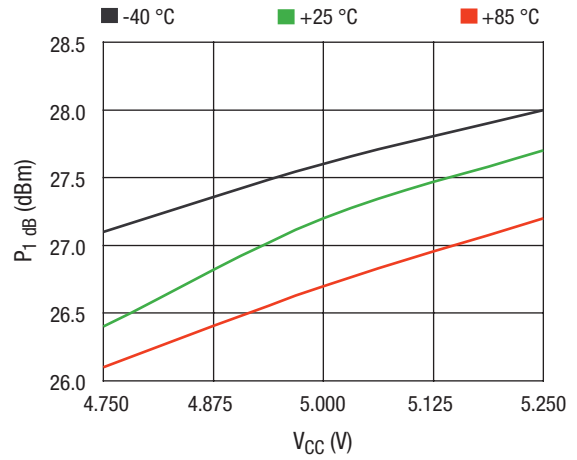

P_1 dB vs. V_{CC} Across Temperature

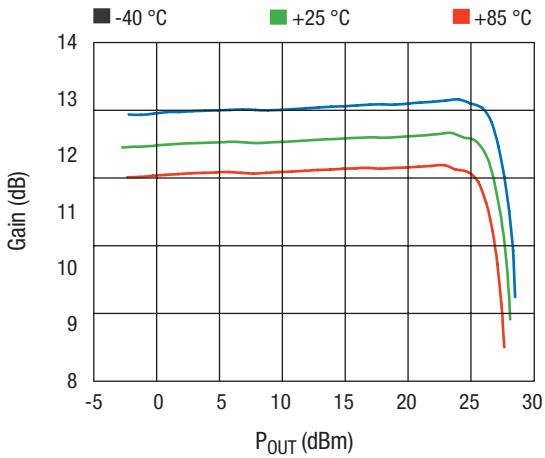

Gain vs. P_{OUT} Across Temperature

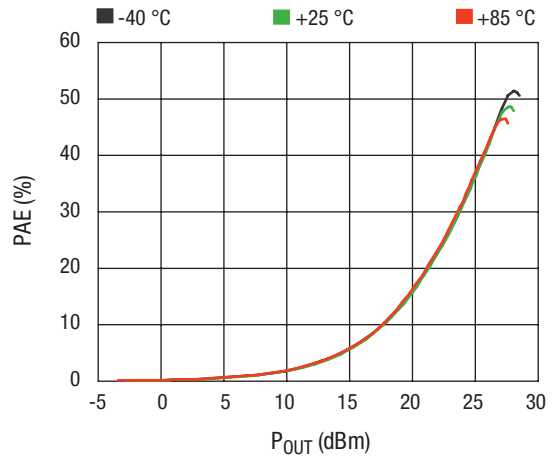

PAE vs. P_{OUT} Across Temperature

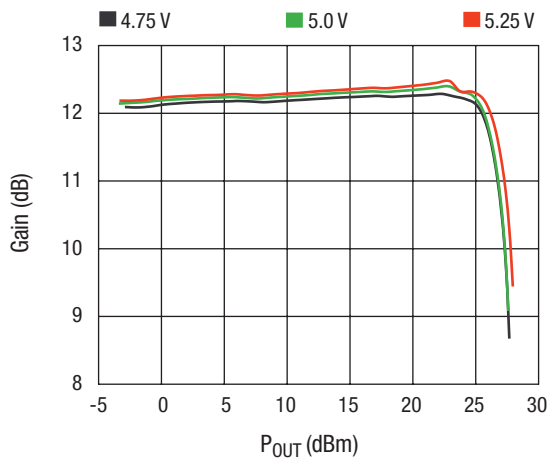

Gain vs. P_{OUT} Across V_{CC}

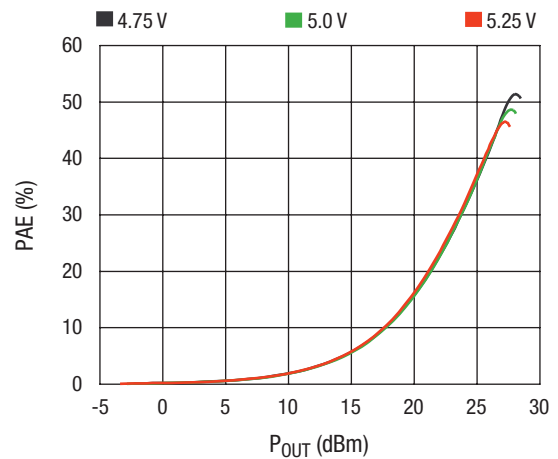

PAE vs. P_{OUT} Across V_{CC}

Typical Performance Data

$V_{CC} = 5\text{ V}$, $Z_0 = 50\ \Omega$, $T_C = 25\ ^\circ\text{C}$, $F = 1960\text{ MHz}$ (best OIP3 match), unless otherwise noted

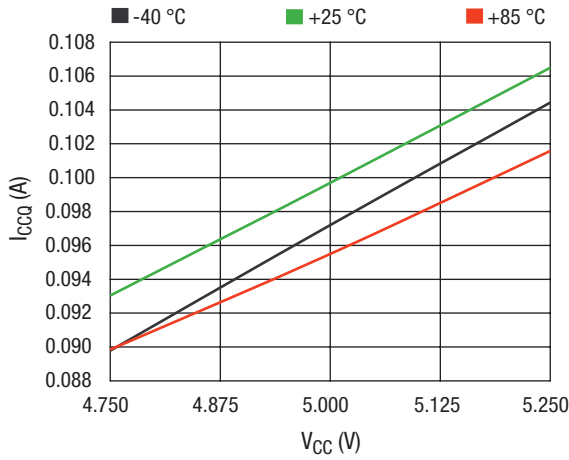

Quiescent Current vs. V_{CC} Across Temperature

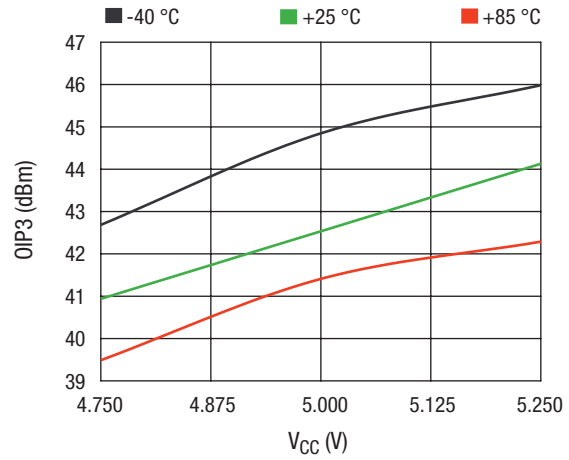

OIP3 vs. V_{CC} Across Temperature, $P_{IN}/\text{Tone} = -1\text{ dBm}$

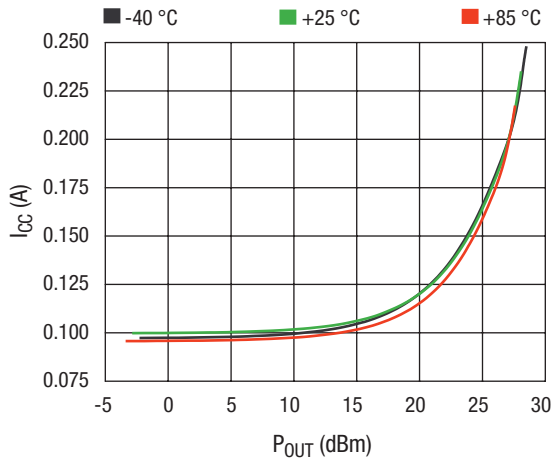

I_{CC} vs. P_{OUT} Across Temperature

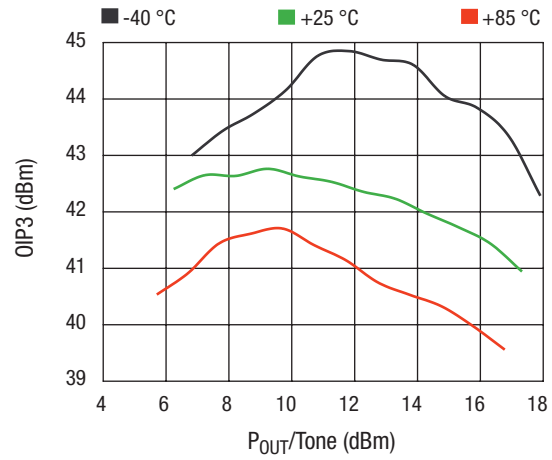

OIP3 vs. P_{OUT}/Tone Across Temperature

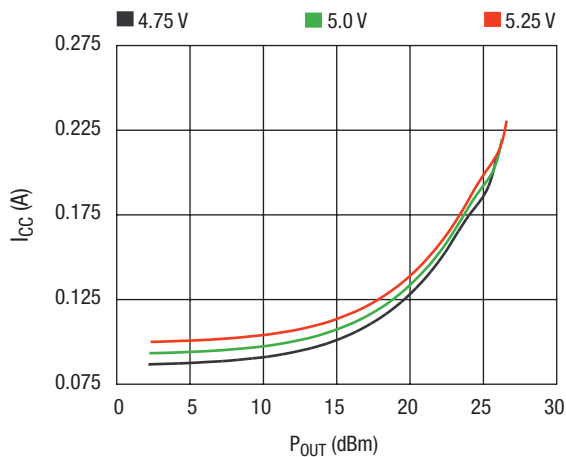

I_{CC} vs. P_{OUT} Across V_{CC}

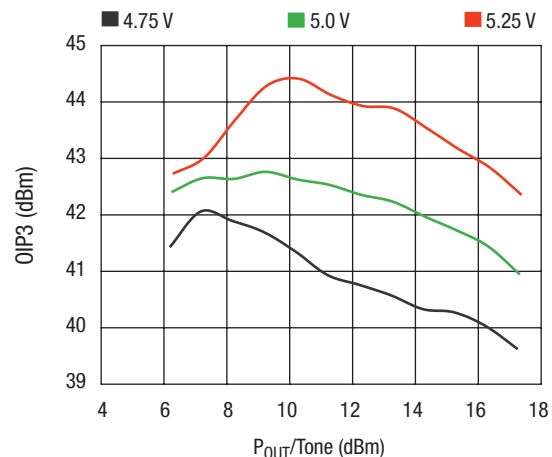

OIP3 vs. P_{OUT}/Tone Across V_{CC}

Typical Performance Data

$V_{CC} = 5\text{ V}$, $Z_0 = 50\ \Omega$, $T_C = 25\ ^\circ\text{C}$, $F = 1960\ \text{MHz}$ (best OIP3 match), unless otherwise noted

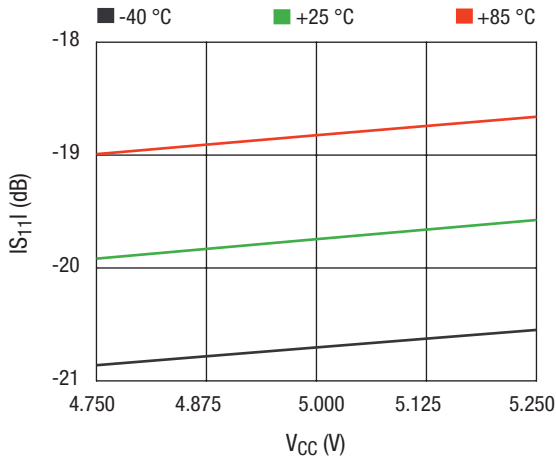

|S₁₁| vs. V_{CC} Across Temperature

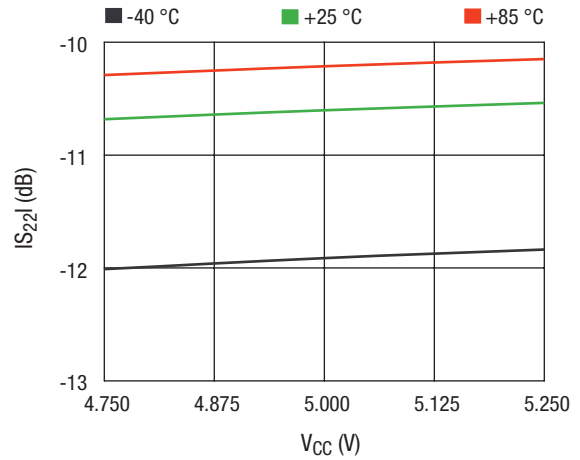

|S₂₂| vs. V_{CC} Across Temperature

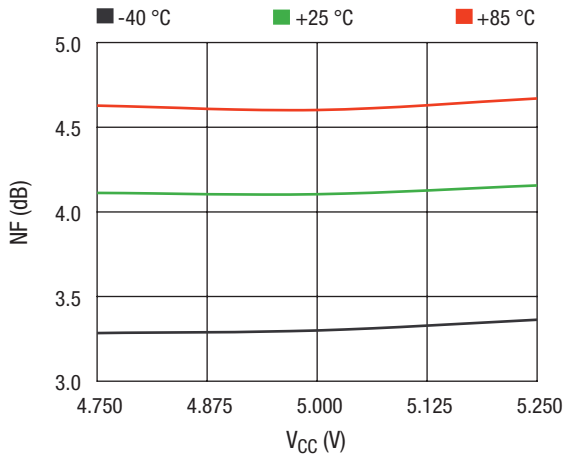

NF vs. V_{CC} Across Temperature

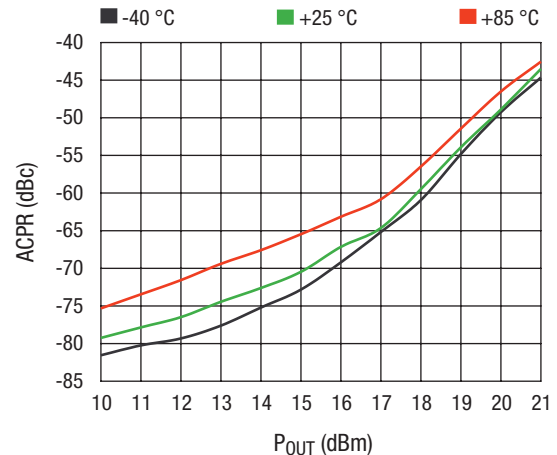

ACPR vs. P_{OUT} Across Temperature

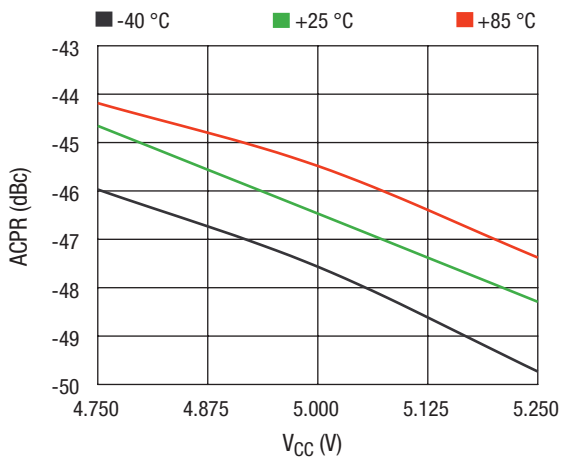

ACPR vs. V_{CC} Across Temperature @ P_{OUT} = 20 dBm

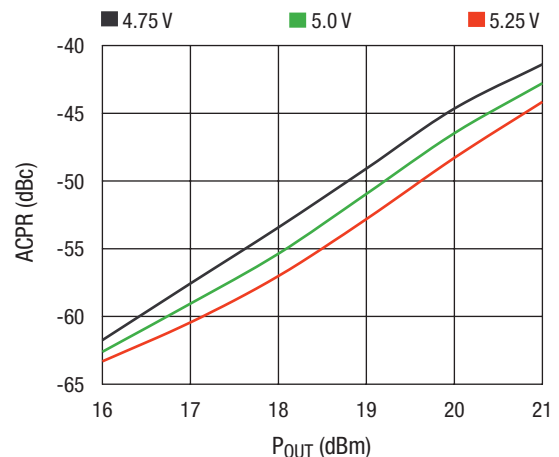

ACPR vs. P_{OUT} Across V_{CC}

Typical Performance Data

$V_{CC} = 5\text{ V}$, $Z_0 = 50\ \Omega$, $T_C = 25\ ^\circ\text{C}$, $F = 2140\ \text{MHz}$, unless otherwise noted

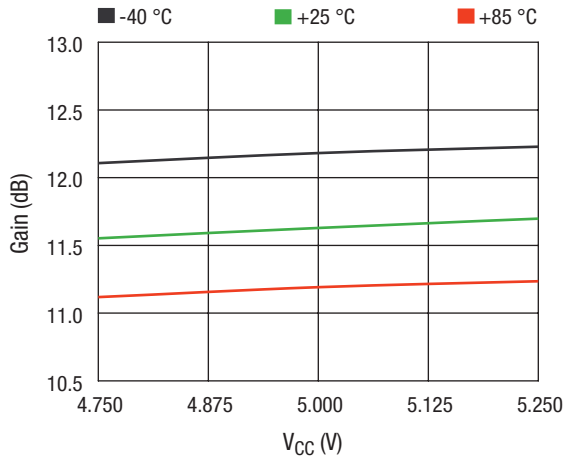

Gain vs. V_{CC} Across Temperature @ $P_{IN} -15\ \text{dBm}$

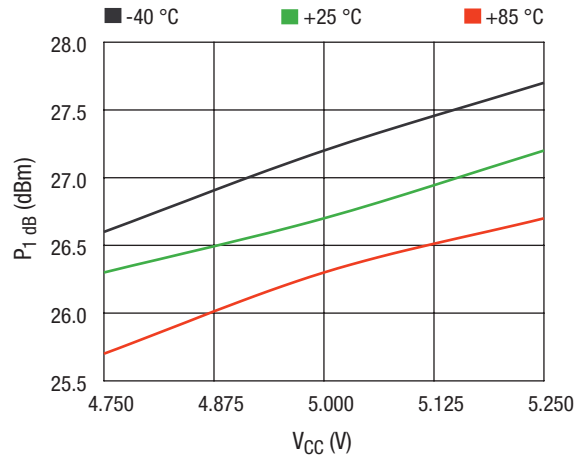

$P_1\ \text{dB}$ vs. V_{CC} Across Temperature

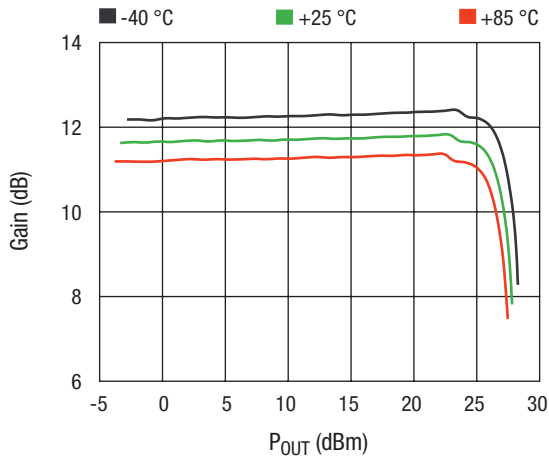

Gain vs. P_{OUT} Across Temperature

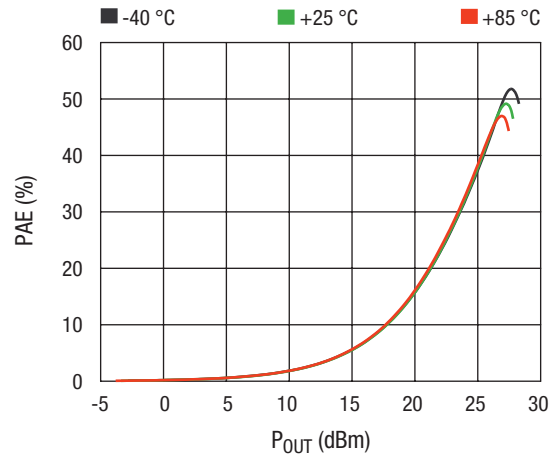

PAE vs. P_{OUT} Across Temperature

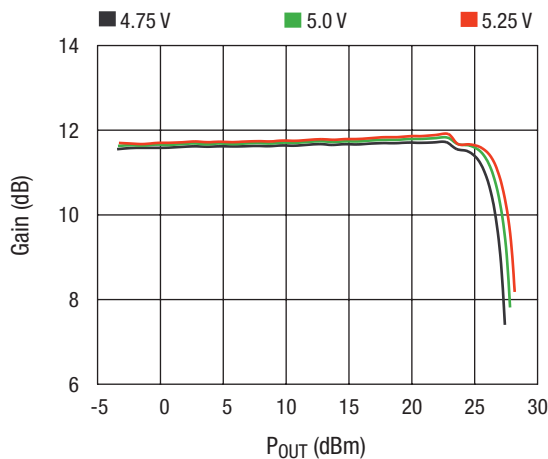

Gain vs P_{OUT} Across V_{CC}

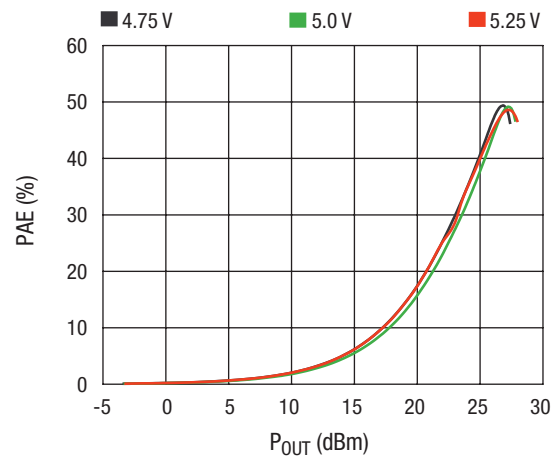

PAE vs. P_{OUT} Across V_{CC}

Typical Performance Data

$V_{CC} = 5\text{ V}$, $Z_0 = 50\ \Omega$, $T_C = 25\ ^\circ\text{C}$, $F = 2140\text{ MHz}$, unless otherwise noted

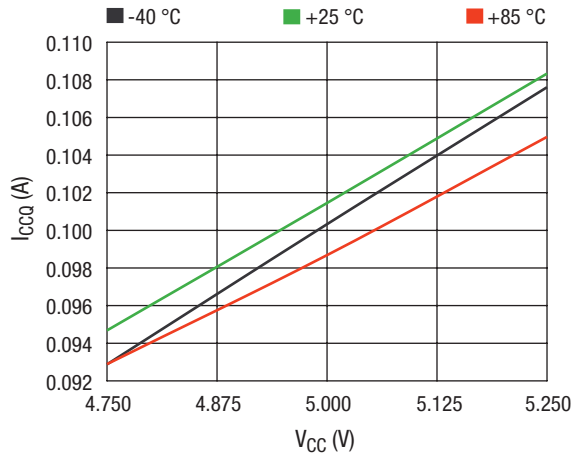

Quiescent Current vs. V_{CC} Across Temperature

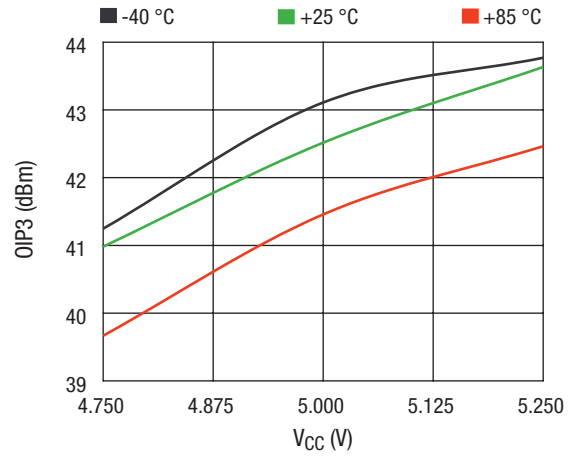

OIP3 vs. V_{CC} Across Temperature, $P_{IN}/\text{Tone} = 0\text{ dBm}$

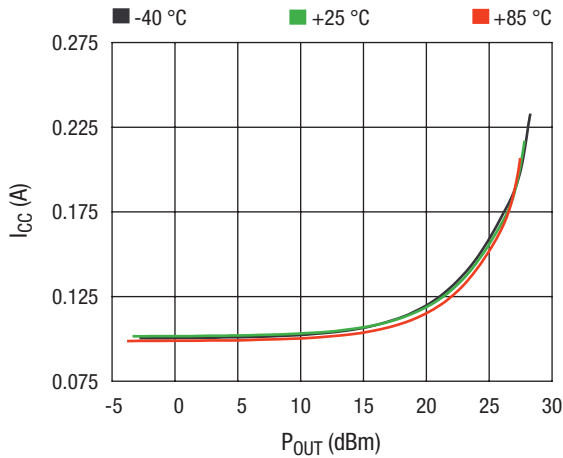

I_{CC} vs. P_{OUT} Across Temperature

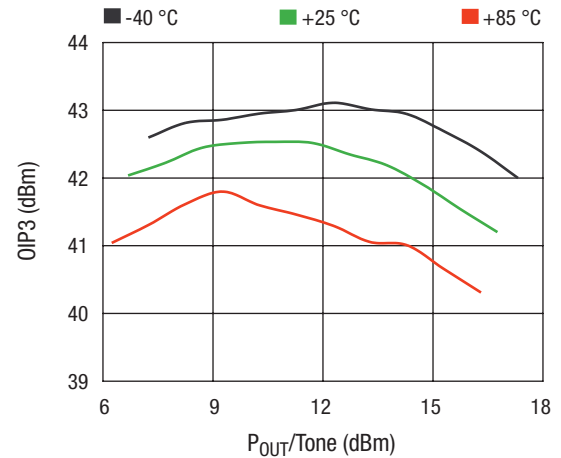

OIP3 vs. P_{OUT}/Tone Across Temperature

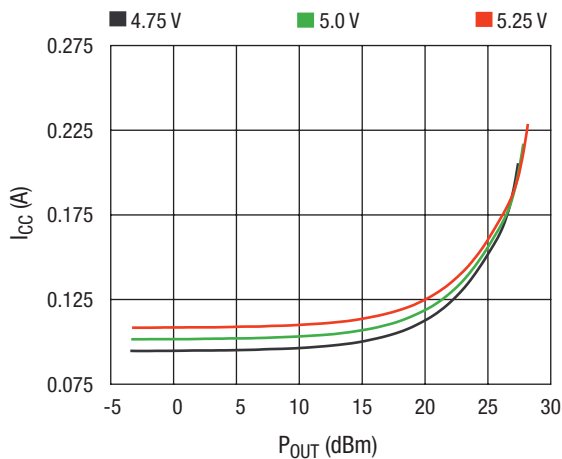

I_{CC} vs. P_{OUT} Across V_{CC}

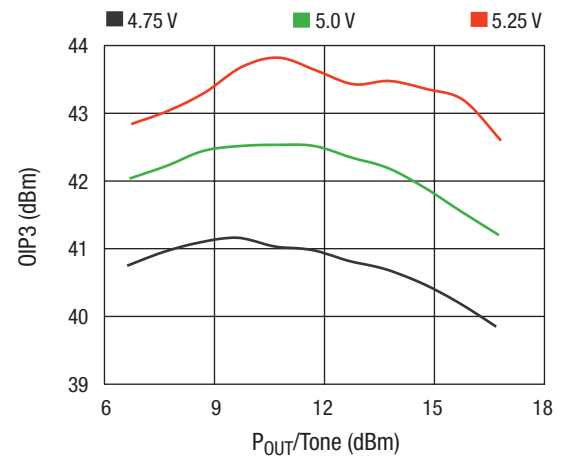

OIP3 vs. P_{OUT}/Tone Across V_{CC}

Typical Performance Data

$V_{CC} = 5\text{ V}$, $Z_0 = 50\ \Omega$, $T_C = 25\ ^\circ\text{C}$, $F = 2140\ \text{MHz}$, unless otherwise noted

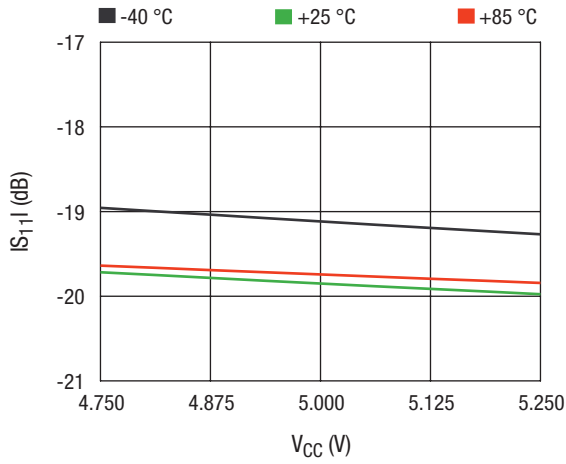

|S₁₁| vs. V_{CC} Across Temperature

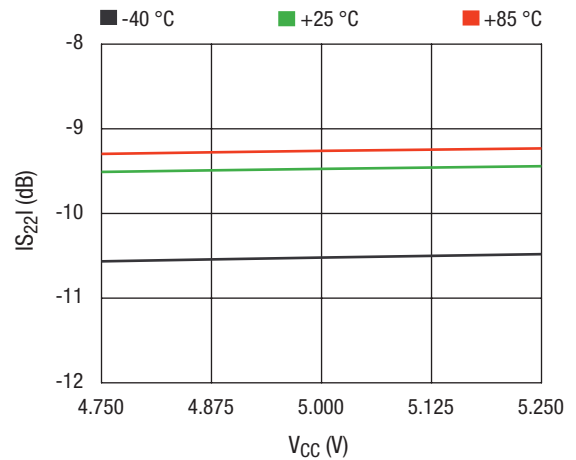

|S₂₂| vs. V_{CC} Across Temperature

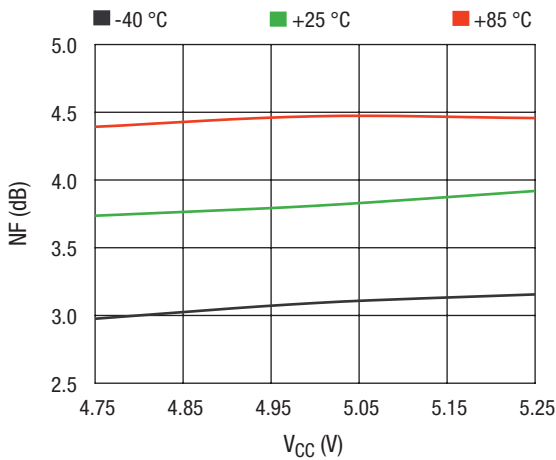

NF vs. V_{CC} Across Temperature

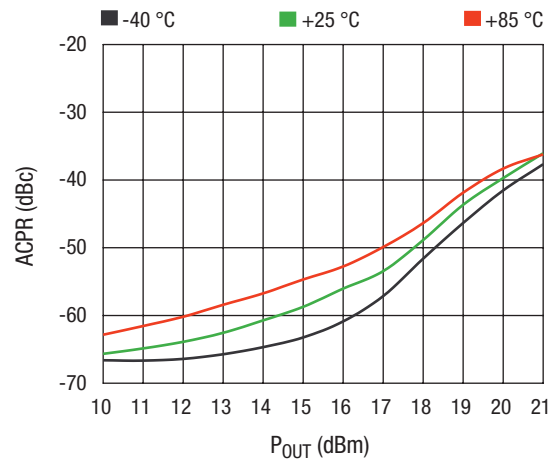

ACPR vs. P_{OUT} Across Temperature

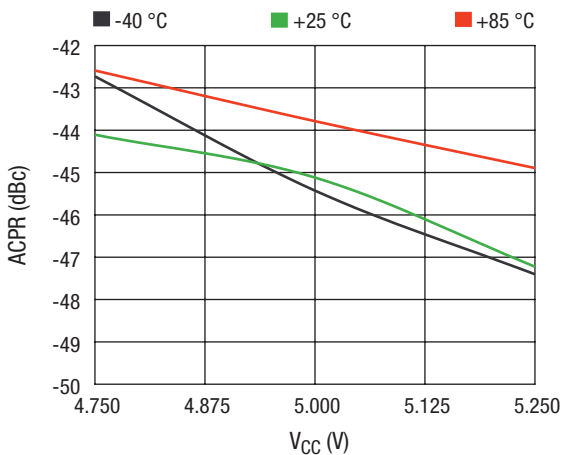

ACPR vs. V_{CC} Across Temperature @ P_{OUT} = 18 dBm

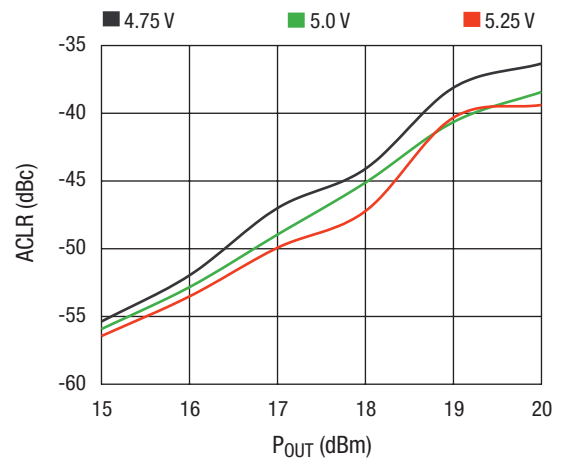

ACLR vs. P_{OUT} Across V_{CC}

Typical Performance Data

$V_{CC} = 5\text{ V}$, $Z_0 = 50\ \Omega$, $T_C = 25\ ^\circ\text{C}$, $F = 2450\ \text{MHz}$, unless otherwise noted

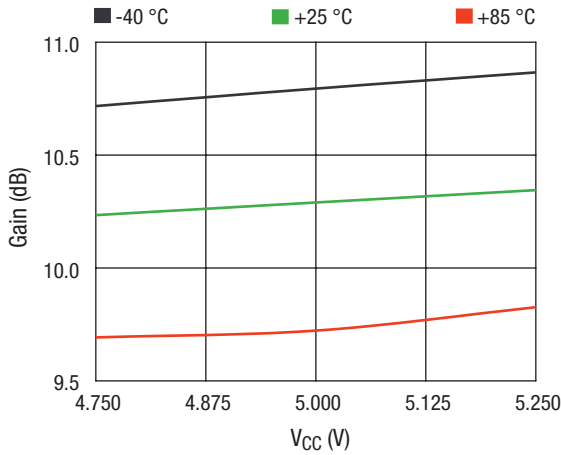

Gain vs. V_{CC} Across Temperature @ $P_{IN} -15\ \text{dBm}$

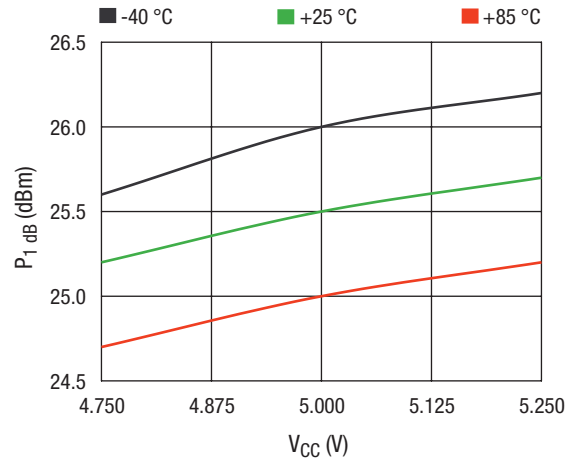

P_1 dB vs. V_{CC} Across Temperature

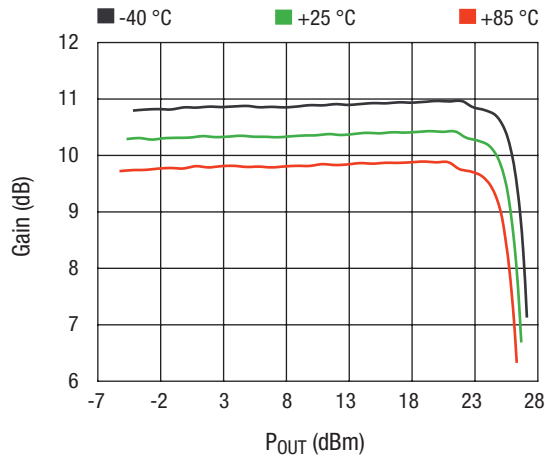

Gain vs. P_{OUT} Across Temperature

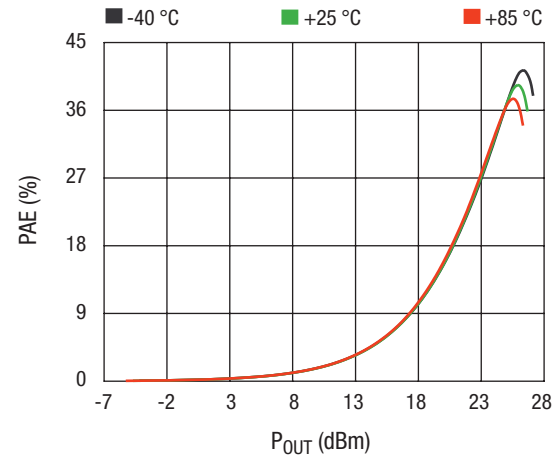

PAE vs. P_{OUT} Across Temperature

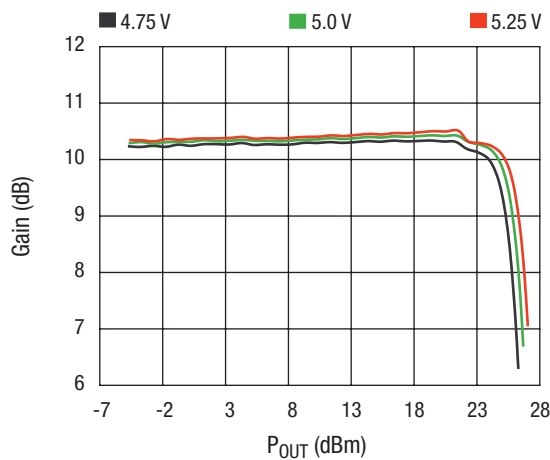

Gain vs. P_{OUT} Across V_{CC}

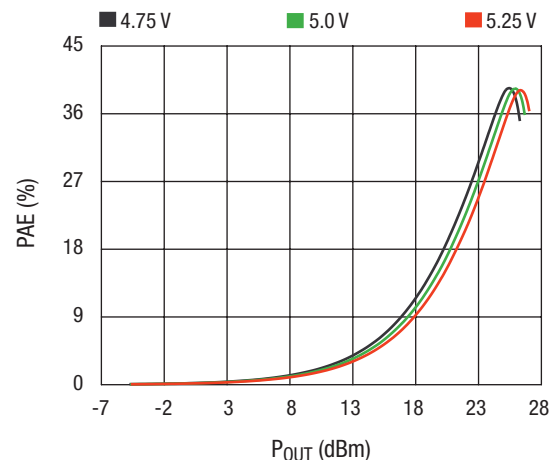

PAE vs. P_{OUT} Across V_{CC}

Typical Performance Data

$V_{CC} = 5\text{ V}$, $Z_0 = 50\ \Omega$, $T_C = 25\ ^\circ\text{C}$, $F = 2450\text{ MHz}$, unless otherwise noted

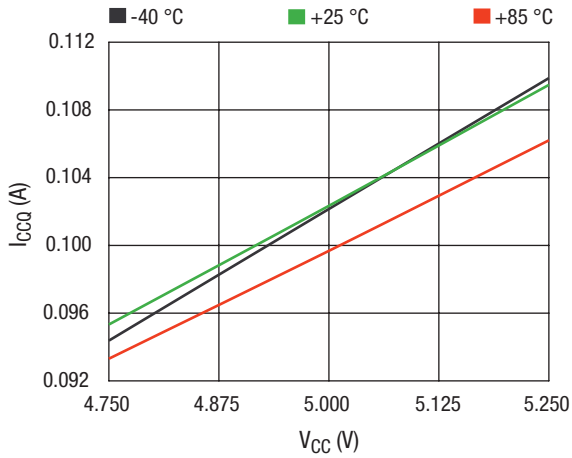

Quiescent Current vs. V_{CC} Across Temperature

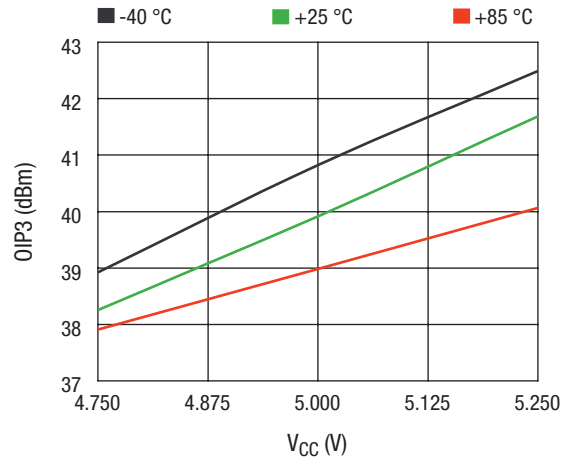

OIP3 vs. V_{CC} Across Temperature, $P_{1M}/\text{Tone} = 0\text{ dBm}$

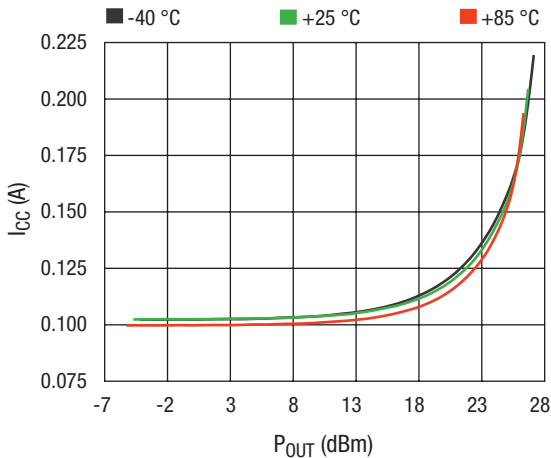

I_{CC} vs. P_{OUT} Across Temperature

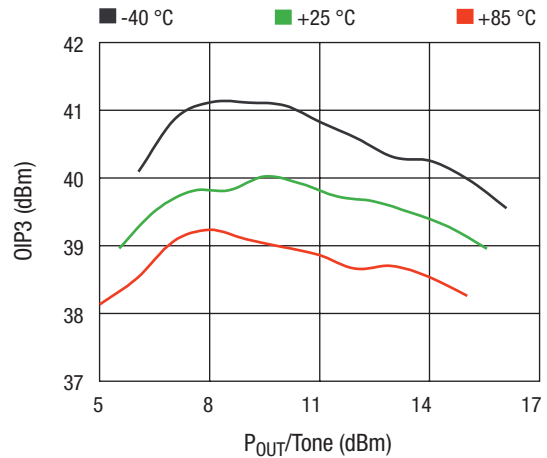

OIP3 vs. P_{OUT}/Tone Across Temperature

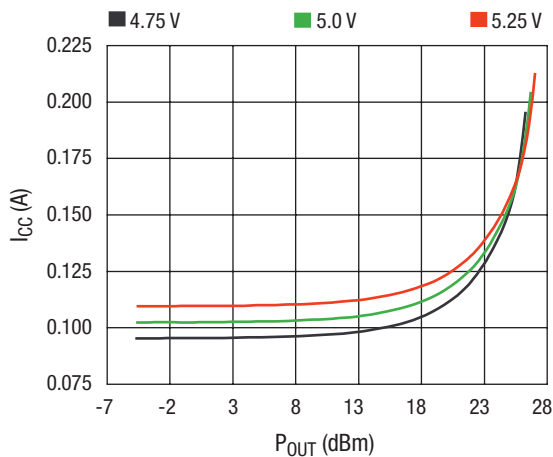

I_{CC} vs. P_{OUT} Across V_{CC}

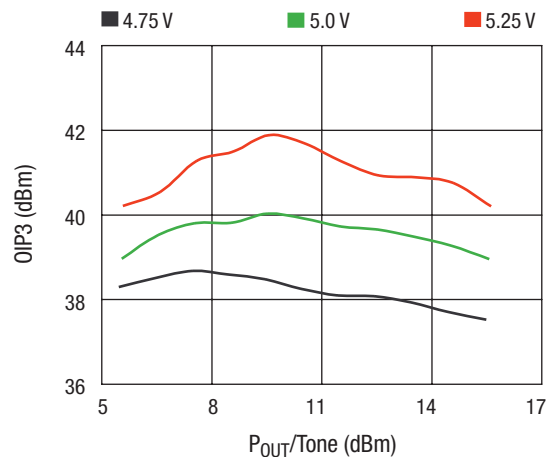

OIP3 vs. P_{OUT}/Tone Across V_{CC}

Typical Performance Data

V_{CC} = 5 V, Z₀ = 50 Ω, T_C = 25 °C, F = 2450 MHz, unless otherwise noted

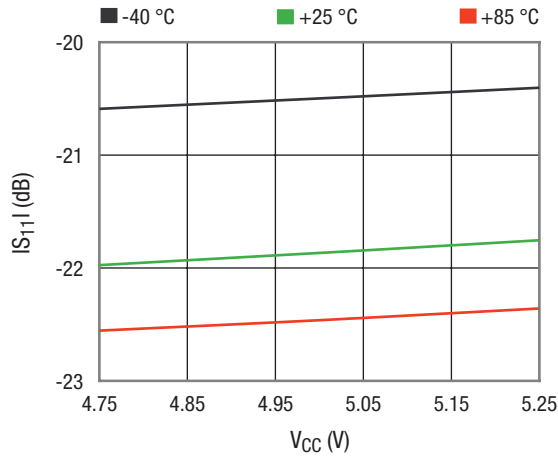

|S₁₁| vs. V_{CC} Across Temperature

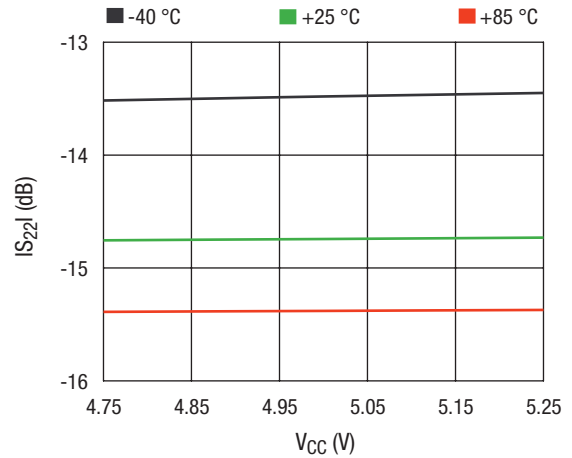

|S₂₂| vs. V_{CC} Across Temperature

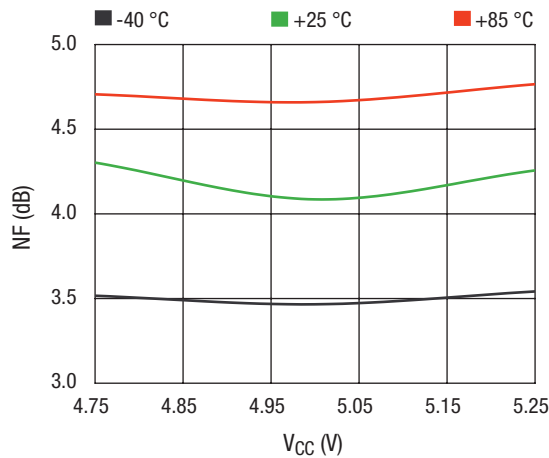

NF vs. V_{CC} Across Temperature

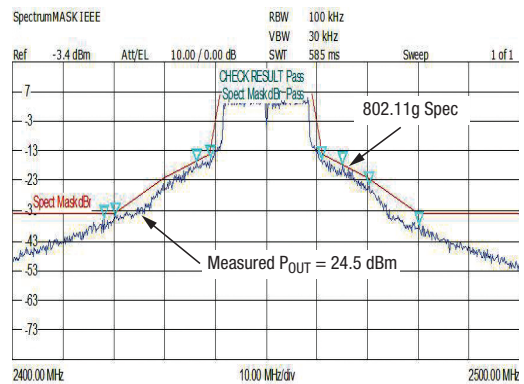

Spectral Response (802.11g 64 QAM @ 54 Mbps Input Signal)

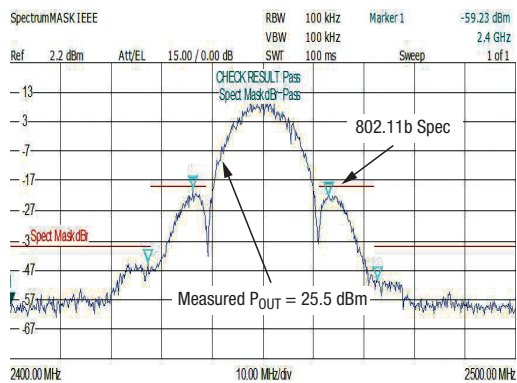

Spectral Response (802.11b CCK @ 11 Mbps Input Signal)

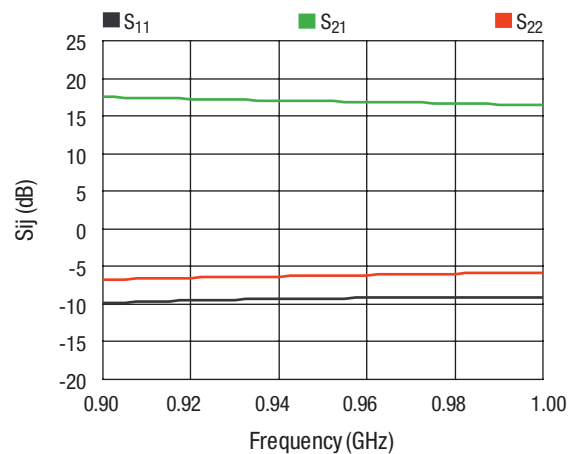

SP vs. Frequency T = 25 °C Tuned for 900 MHz

Typical Performance Data

$V_{CC} = 5\text{ V}$, $Z_0 = 50\ \Omega$, $T_C = 25\ ^\circ\text{C}$, unless otherwise noted

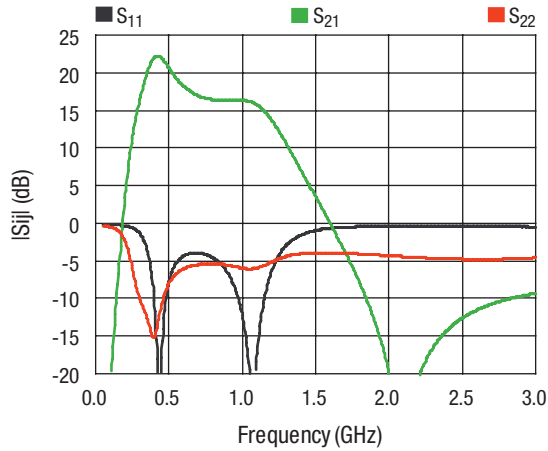

**S-Parameters vs. Frequency
Tuned for 450 MHz**

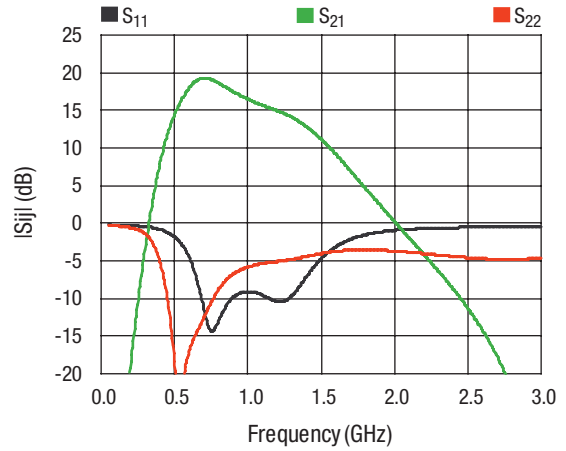

**S-Parameters vs. Frequency
Tuned for 900 MHz**

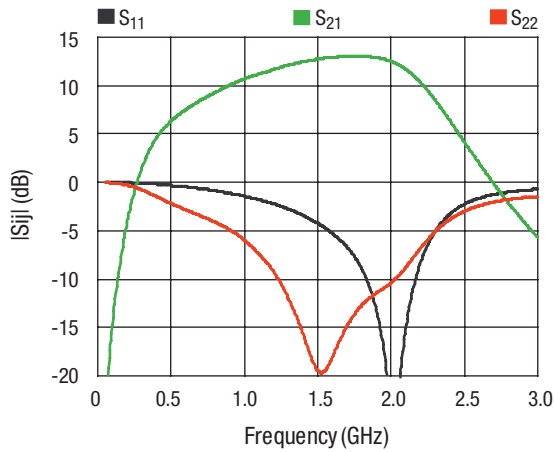

**S-Parameters vs. Frequency
Tuned for 1960 MHz**

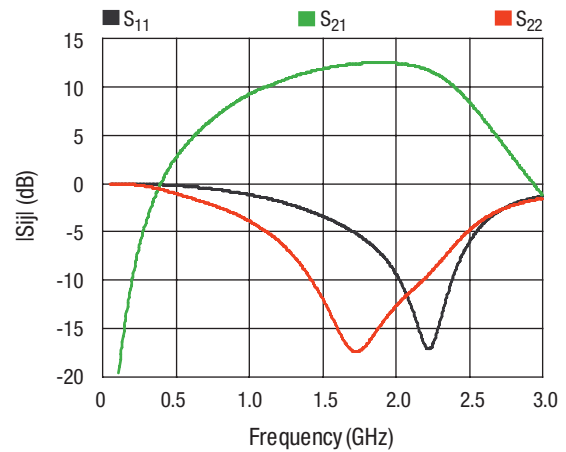

**S-Parameters vs. Frequency
Tuned for 2140 MHz**

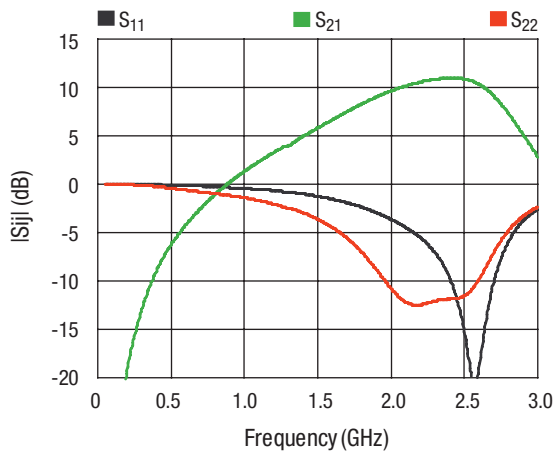

**S-Parameters vs. Frequency
Tuned for 2450 MHz**

Theory of Operation

The SKY65009-70LF is a single stage, wideband power amplifier in a low-cost surface mount package. The device operates with a single 3 V or 5 V power supply connected through an RF choke (L1) to the output pin. Capacitors C7, C8 and C9 provide DC bias decoupling for V_{CC} . The bias current is set by the on-chip active bias composed of current mirror and reference voltage transistors, allowing for excellent gain tracking over temperature and voltage variations. The part is externally RF matched using surface mount components to facilitate operation over a frequency range of 250 to 2500 MHz.

Pin 1 is the RF input and Pin 3 is the RF output. External DC blocking is required on the input and output, but can be implemented as part of the RF matching circuit. Pin 2 and the package backside metal, Pin 4, provide the DC and RF ground.

Application Circuit Notes

RF In (Pin 1). Amplifier RF input pin. The amplifier requires a DC blocking capacitor as part of the external RF matching.

Ground (Pin 2). Attach the ground pin to the RF ground plane with the largest diameter and lowest inductance via that the layout will allow. Multiple small vias are also acceptable and will work well under the device if solder migration is an issue.

RF Out/ V_{CC} (Pin 3). Amplifier RF output pin. The amplifier requires a DC blocking capacitor as part of the external RF matching. The amplifier collector supply voltage is supplied through an RF choke to the output at pin 3.

Center Ground (Pin 4). It is extremely important that the device paddle be sufficiently grounded for both thermal and stability reasons. Multiple small vias are acceptable and will work well under the device if solder migration is an issue.

Package and Handling Information

Since the device package is sensitive to moisture absorption, it is baked and vacuum packed before shipping. Instructions on the shipping container label regarding exposure to moisture after the container seal is broken must be followed. Otherwise, problems related to moisture absorption may occur when the part is subjected to high temperature during solder assembly.

Please refer to Skyworks solder reflow application note, available at www.skyworksinc.com, for instructions on mounting the SKY65009-70LF to a printed circuit board.

Production quantities of this product are shipped in a standard tape and reel format. For packaging details, refer to the Skyworks Application Note, Tape and Reel, document number 101568.

Electrostatic Discharge (ESD) Sensitivity

The SKY65009-70LF is a static-sensitive electronic device. Do not operate or store near strong electrostatic fields. Take proper ESD precautions.

Evaluation Board Schematic

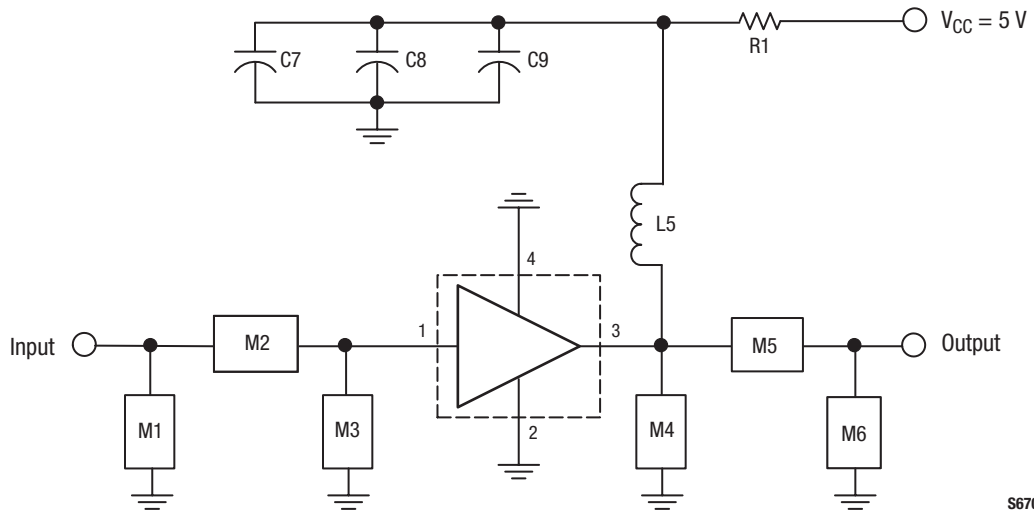

S670

Evaluation Board Component Values vs. Frequency

Component	Evaluation Board Frequency (MHz)					
	450 MHz	900 MHz	1960 MHz (OIP3)	1960 MHz (ACPR)	2140 MHz	2450 MHz
R1	0 Ω	0 Ω	0 Ω	0 Ω	0 Ω	0 Ω
C7	1 μF	1 μF	1 μF	1 μF	1 μF	1 μF
C8	1000 pF	1000 pF	1000 pF	1000 pF	1000 pF	1000 pF
C9	68 pF	68 pF	18 pF	18 pF	18 pF	15 pF
L5	47 nH	47 nH	27 nH	22 nH	22 nH	22 nH
M1	8.2 nH	8.2 nH	1.8 nH	1.2 pF	1.2 pF	1 pF
M2	12 pF	4.7 pF	2.7 pF	2.2 pF	2.2 pF	1.2 pF
M3	6.8 pF	4.7 pF	DNC	DNC	DNC	DNC
M4	DNC	DNC	1.2 pF	1.2 pF	1.2 pF	DNC
M5	12 pF	6.8 pF	5.6 pF	3.3 pF	3.3 pF	2.2 pF
M6	27 nH	12 nH	1.0 pF	0.5 pF	0.5 pF	1.2 pF

Bill of Material for Evaluation Board

Part	Size	Value	Units	Product Number	Manufacturer	Manufacturer's Part Number	Characteristics
1	0603	8.2	nH	5332R34-018	Taiyo-Yuden	HK16088N2J-T	± 5%, SRF 3500 MHz
2	0603	12	nH	5332R34-022	Taiyo-Yuden	HK160812NJ-T	± 5%, SRF 2600 MHz
3	0603	22	nH	5332R34-028	Taiyo-Yuden	HK160822NJ-T	± 5%, SRF 1600 MHz
4	0603	27	nH	5332R34-030	Taiyo-Yuden	HK160827NJ-T	± 5%, SRF 1400 MHz
5	0603	47	nH	5332R34-036	Taiyo-Yuden	HK160847NJ-T	± 5%, SRF 900 MHz
6	0603	0.5	pF	5404R98-001	Murata	GRM1885C1HR50CZ01D	COG, 50 V, ± 0.25 pF
7	0603	1	pF	5404R23-035	Murata	GRM1885C1H1R0CZ01D	COG, 50 V, ± 0.25 pF
8	0603	1.2	pF	5404R23-036	Murata	GRM1885C1H1R2CD27J	COG, 50 V, ± 0.25 pF
9	0603	1.8	pF	5404R23-038	Murata	GRM1885C1H1R8CZ01J	COG, 50 V, ± 0.25 pF
10	0603	2.2	pF	5404R23-039	Murata	GRM1885C1H2R2CZ01D	COG, 50 V, ± 0.25 pF
11	0603	2.7	pF	5404R23-040	Murata	GRM1885C1H2R7CZ01D	COG, 50 V, ± 0.25 pF
12	0603	3.3	pF	5404R23-041	Murata	GRM1885C1H3R3CZ01D	COG, 50 V, ± 0.25 pF
13	0603	4.7	pF	5404R98-006	Murata	GRM1885C1H4R7CZ01D	COG, 50 V, ± 0.25 pF
14	0603	5.6	pF	5404R23-010	Murata	GRM1885C1H5R6DZ01D	COG, 50 V, ± 0.50 pF
15	0603	6.8	pF	5404R23-045	Murata	GRM1885C1H6R8CD01J	COG, 50 V, ± 0.25 pF
16	0603	12	pF	5404R23-014	Murata	GRM1885C1H120JD51D	COG, 50 V, ± 5%
17	0603	15	pF	5404R23-015	Murata	GRM1885C1H150JD51D	COG, 50 V, ± 5%
18	0603	18	pF	5404R23-016	Murata	GRM1885C1H180JD51D	COG, 50 V, ± 5%
19	0603	68	pF	5404R23-023	Murata	GRM1885C1H680JD51D	COG, 50 V, ± 5%
20	0603	1000	pF	5404R23-057	TDK	C1608C0G1H102JT	COG, 50 V, ± 5%
21	0805	1	µF	5404R29-070	TDK	C2012X7R1H104K	X7R, 50 V, ± 10%
22	0603	0	Ω	5424R20-146	Rohm	MCR03EZHJ000	50 V, 0.063 W, ± 5%

Evaluation Board Description

The Skyworks SKY65009-70LF Evaluation Board is used to test the performance of the SKY65009-70LF power amplifier module. The following design considerations are general in nature and must be followed regardless of final use or configuration.

1. Paths to ground should be made as short as possible.
2. The ground pad of the SKY65009-70LF power amplifier module has special electrical and thermal grounding requirements. This pad is the main thermal conduit for heat dissipation. Since the circuit board acts as the heat sink, it must shunt as much heat as possible from the amplifiers. As such, design the connection to the ground pad to dissipate the maximum wattage produced to the circuit. Multiple vias to the grounding layer are required.
3. Bypass capacitors should be used on the DC supply lines. RF inductor is required on the V_{CC} supply line to block RF signal from the DC supply. See Evaluation Board schematic drawing for more details.

4. The RF lines should be well separated from each other, with solid ground in between traces, to maximize input-to-output isolation.

NOTE: Junction temperature (*T_j*) of the device increases with a poor connection to the slug and ground. This reduces the lifetime of the device.

Pin Descriptions

Pin #	Name	Description
1	RF In	RF input
2	GND	Ground
3	RF Out	RF output/V _{CC}
4	GND	Center ground

Center attachment pad must have a low inductance and low thermal resistance connection to the customer's printed circuit board ground plane.

Evaluation Board Test Procedure

Use the following procedure to set up the SKY65009-70LF evaluation board for testing.

1. Connect a 5.0 V supply to V_{CC} . If available, enable the current limiting function of the power supply to 300 mA.
2. Connect a signal generator to the RF signal input port. Set it to the desired RF frequency at a power level of -15 dBm or less to the evaluation board, but do NOT enable the RF signal.
3. Connect a spectrum analyzer to the RF signal output port.
4. Enable the power supply.

5. Enable the RF signal.
6. Take measurements.

CAUTION: If the input signal exceeds the rated power, the SKY65009-70LF Evaluation Board can be permanently damaged.

NOTE: It is important that the V_{CC} voltage source be adjusted such that 5.0 V is measured at the board. The high collector currents will drop the collector voltage significantly if long leads are used. Adjust the bias voltage to compensate.

Evaluation Board

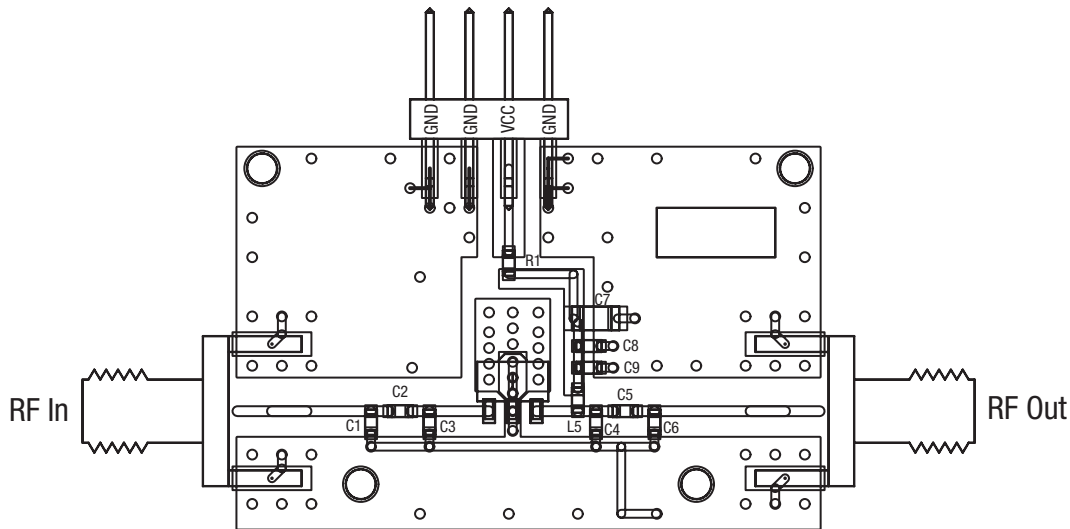

S708

Evaluation Board Layer Detail

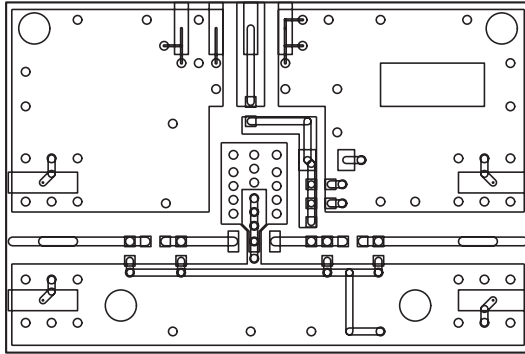

Layer 1: Top - Metal

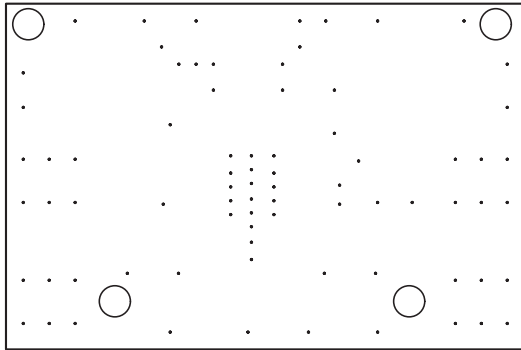

Layer 2: Ground

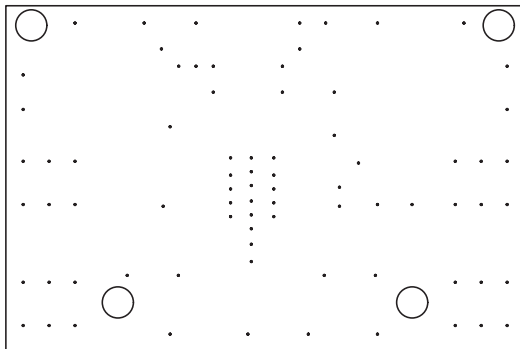

Layer 3: Ground

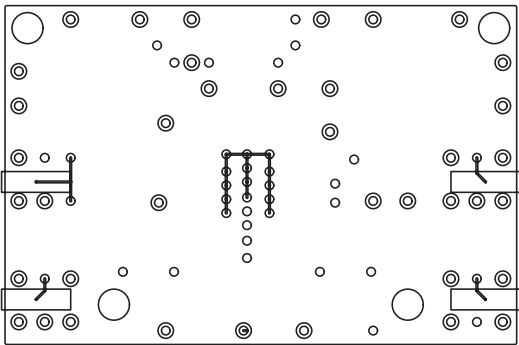

Layer 4: Solid Ground Plane

S709

Evaluation Board Stack-Up

Cross Section	Name	Thickness (mil)	Material	ϵ_r
	L1	1.4	Cu	-
	Lam1	12	Rogers 4003-12	3.38
	L2	1.4	Cu, 1 oz.	-
	Lam2	4	FR4-4	4.35
	L3	1.4	Cu, 1 oz.	-
	Lam3	12	FR4-12	4.35
	L4	1.4	Cu, 1 oz.	-

Branding Specifications

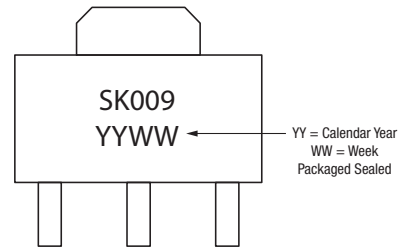

Recommended Solder Reflow Profiles

Refer to the [“Recommended Solder Reflow Profile”](#) Application Note.

Tape and Reel Information

Refer to the [“Discrete Devices and IC Switch/Attenuators Tape and Reel Package Orientation”](#) Application Note.

Package Dimensions

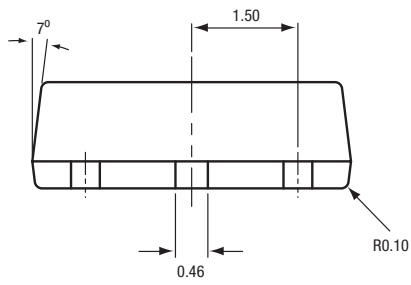

Side View

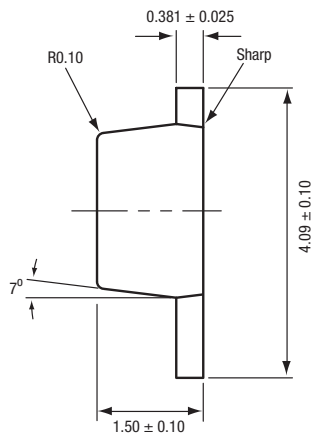

End View

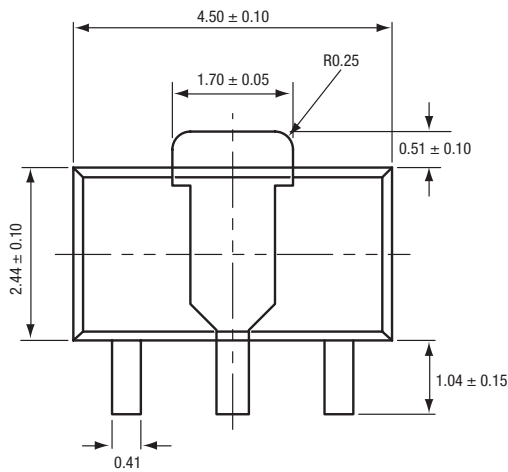

Bottom View

All measurements are in millimeters

Recommended Footprint

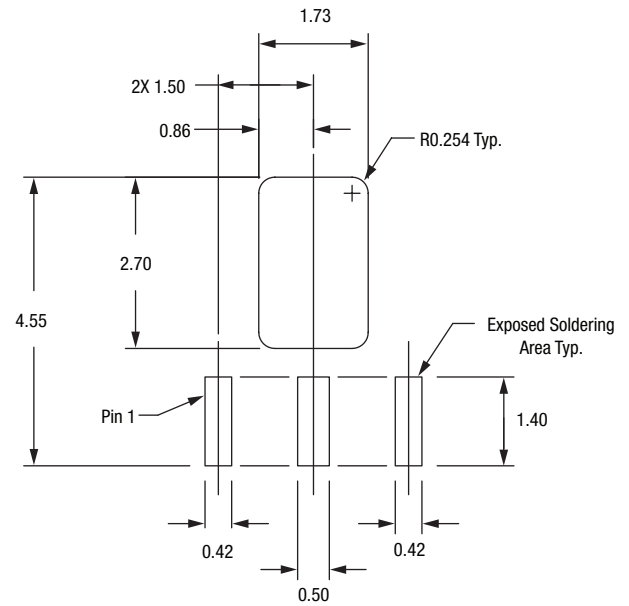

All measurements are in mm.

Tape and Reel Dimensions

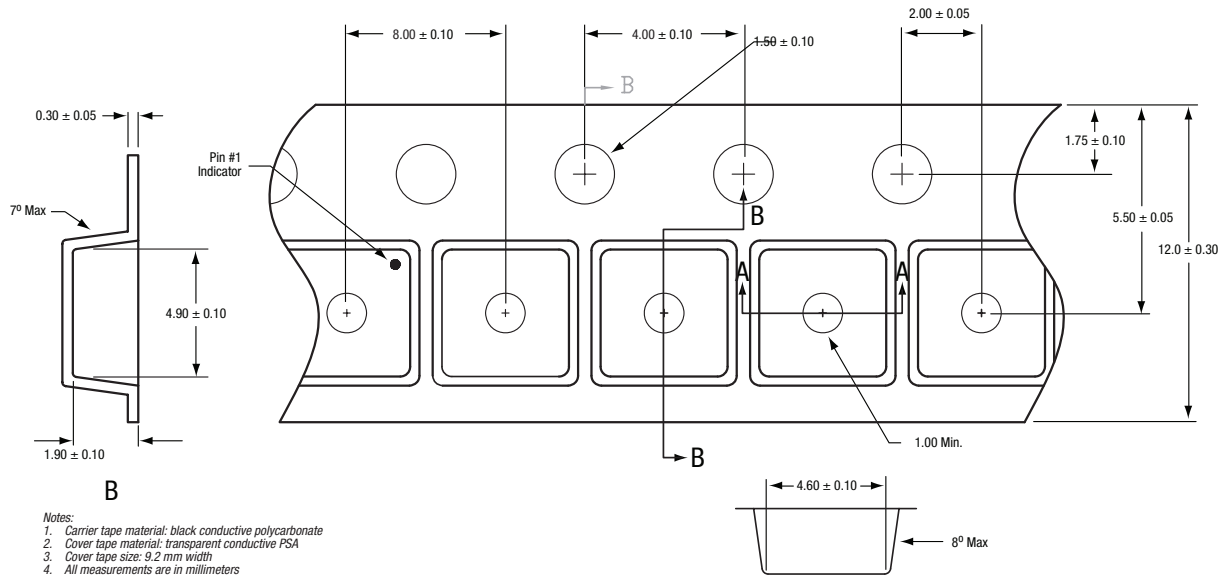

S264

Ordering Information

Model Name	Manufacturing Part Number	Evaluation Kit Part Number
SKY65009-70LF: 250–2500 MHz Linear Power Amplifier Driver	SKY65009-70LF (Pb-free package)	TW13-D281-101 (450 MHz) TW13-D282-101 (900 MHz) TW13-D283-101 (1960 MHz - OIP3) TW13-D284-101 (1960 MHz - ACPR) TW13-D285-101 (2140 MHz) TW13-D286-101 (2450 MHz)

Copyright © 2002, 2003, 2004, 2005, 2006, 2007, 2008, 2009, Skyworks Solutions, Inc. All Rights Reserved.

Information in this document is provided in connection with Skyworks Solutions, Inc. (“Skyworks”) products or services. These materials, including the information contained herein, are provided by Skyworks as a service to its customers and may be used for informational purposes only by the customer. Skyworks assumes no responsibility for errors or omissions in these materials or the information contained herein. Skyworks may change its documentation, products, services, specifications or product descriptions at any time, without notice. Skyworks makes no commitment to update the materials or information and shall have no responsibility whatsoever for conflicts, incompatibilities, or other difficulties arising from any future changes.

No license, whether express, implied, by estoppel or otherwise, is granted to any intellectual property rights by this document. Skyworks assumes no liability for any materials, products or information provided hereunder, including the sale, distribution, reproduction or use of Skyworks products, information or materials, except as may be provided in Skyworks Terms and Conditions of Sale.

THE MATERIALS, PRODUCTS AND INFORMATION ARE PROVIDED “AS IS” WITHOUT WARRANTY OF ANY KIND, WHETHER EXPRESS, IMPLIED, STATUTORY, OR OTHERWISE, INCLUDING FITNESS FOR A PARTICULAR PURPOSE OR USE, MERCHANTABILITY, PERFORMANCE, QUALITY OR NON-INFRINGEMENT OF ANY INTELLECTUAL PROPERTY RIGHT; ALL SUCH WARRANTIES ARE HEREBY EXPRESSLY DISCLAIMED. SKYWORKS DOES NOT WARRANT THE ACCURACY OR COMPLETENESS OF THE INFORMATION, TEXT, GRAPHICS OR OTHER ITEMS CONTAINED WITHIN THESE MATERIALS. SKYWORKS SHALL NOT BE LIABLE FOR ANY DAMAGES, INCLUDING BUT NOT LIMITED TO ANY SPECIAL, INDIRECT, INCIDENTAL, STATUTORY, OR CONSEQUENTIAL DAMAGES, INCLUDING WITHOUT LIMITATION, LOST REVENUES OR LOST PROFITS THAT MAY RESULT FROM THE USE OF THE MATERIALS OR INFORMATION, WHETHER OR NOT THE RECIPIENT OF MATERIALS HAS BEEN ADVISED OF THE POSSIBILITY OF SUCH DAMAGE.

Skyworks products are not intended for use in medical, lifesaving or life-sustaining applications, or other equipment in which the failure of the Skyworks products could lead to personal injury, death, physical or environmental damage. Skyworks customers using or selling Skyworks products for use in such applications do so at their own risk and agree to fully indemnify Skyworks for any damages resulting from such improper use or sale.

Customers are responsible for their products and applications using Skyworks products, which may deviate from published specifications as a result of design defects, errors, or operation of products outside of published parameters or design specifications. Customers should include design and operating safeguards to minimize these and other risks. Skyworks assumes no liability for applications assistance, customer product design, or damage to any equipment resulting from the use of Skyworks products outside of stated published specifications or parameters.

Skyworks, the Skyworks symbol, and “Breakthrough Simplicity” are trademarks or registered trademarks of Skyworks Solutions, Inc., in the United States and other countries. Third-party brands and names are for identification purposes only, and are the property of their respective owners. Additional information, including relevant terms and conditions, posted at www.skyworksinc.com, are incorporated by reference.