



Package: SOT-89



### Product Description

RFMD's SBA-4089 is a high performance InGaP/GaAs Heterojunction Bipolar Transistor MMIC Amplifier. A Darlington configuration designed with InGaP process technology provides broadband performance up to 5GHz with excellent thermal performance. The heterojunction increases breakdown voltage and minimizes leakage current between junctions. Cancellation of emitter junction non-linearities results in higher suppression of intermodulation products. Only a single positive supply voltage, DC-blocking capacitors, a bias resistor, and an optional RF choke are required for operation.

**Optimum Technology Matching® Applied**

- GaAs HBT
- GaAs MESFET
- InGaP HBT
- SiGe BiCMOS
- Si BiCMOS
- SiGe HBT
- GaAs pHEMT
- Si CMOS
- Si BJT
- GaN HEMT
- InP HBT
- RF MEMS
- LDMOS

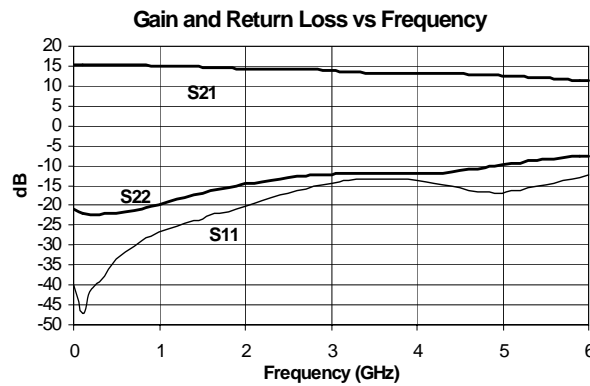

### Features

- Available in RoHS Compliant and Pb-Free (Z Part Number)
- IP<sub>3</sub> = 33.5 dBm at 1950 MHz
- P<sub>OUT</sub> = 13.3 dBm at -45 dBc ACP IS-95 1950 MHz
- Robust 1000V ESD, Class 1C
- Operates From Single Supply
- Patented Thermal Design

### Applications

- PA Driver Amplifier
- Cellular, PCS, GSM, UMTS
- IF Amplifier
- Wireless Data, Satellite Terminals

| Parameter                             | Specification |      |      | Unit | Condition                                      |
|---------------------------------------|---------------|------|------|------|--|
|                                       | Min.          | Typ. | Max. |      |  |
| Small Signal Gain                     | 13.5          | 15.0 | 16.5 | dB   | 850 MHz  |
|                                       | 13.1          | 14.6 | 16.1 | dB   | 1950 MHz                                       |
| Output Power at 1dB Compression       | 17.5          | 19.0 |      | dBm  | 1950 MHz                                       |
|                                       |               | 19.2 |      | dBm  | 850 MHz  |
| Output Third Order Intercept Point    | 31.5          | 33.5 |      | dBm  | 1950 MHz                                       |
|                                       |               | 36.5 |      | dBm  | 850 MHz  |
| Output Power                          |               | 13.3 |      | dBm  | 1950 MHz, -45 dBc ACP IS-95 9 Forward Channels |
| Bandwidth                             |               | 4400 |      | MHz  | Return Loss > 10 dB                            |
| Input Return Loss                     | 14.0          | 21.0 |      | dB   | 1950 MHz                                       |
| Output Return Loss                    | 11.0          | 15.0 |      | dB   | 1950 MHz                                       |
| Noise Figure                          |               | 4.8  | 5.8  | dB   | 1950 MHz                                       |
| Device Operating Voltage              | 4.8           | 5.0  | 5.4  | V    |  |
| Device Operating Current              | 72            | 80   | 88   | mA   |  |
| Thermal Resistance (junction to lead) |               | 70   |      | °C/W |  |

Test Conditions: V<sub>S</sub> = 8V, I<sub>D</sub> = 80 mA Typ., OIP<sub>3</sub> Tone Spacing = 1 MHz, P<sub>OUT</sub> per tone = 0 dBm, R<sub>BIAS</sub> = 39 Ω, T<sub>L</sub> = 25 °C, Z<sub>S</sub> = Z<sub>L</sub> = 50 Ω

## Absolute Maximum Ratings

| Parameter                      | Rating     | Unit |
|--------------------------------|------------|------|
| Device Current ( $I_D$ )       | 130        | mA   |
| Device Voltage ( $V_D$ )       | 6          | V    |
| RF Input Power                 | +17        | dBm  |
| Junction Temp ( $T_J$ )        | +150       | °C   |
| Operating Temp Range ( $T_L$ ) | -40 to +85 | °C   |
| Storage Temp                   | +150       | °C   |
| Operating Dissipated Power     | 0.65       | W    |
| Moisture Sensitivity Level     | MSL 2      |      |



**Caution!** ESD sensitive device.

Exceeding any one or a combination of the Absolute Maximum Rating conditions may cause permanent damage to the device. Extended application of Absolute Maximum Rating conditions to the device may reduce device reliability. Specified typical performance or functional operation of the device under Absolute Maximum Rating conditions is not implied.

RoHS status based on EU Directive 2002/95/EC (at time of this document revision).

The information in this publication is believed to be accurate and reliable. However, no responsibility is assumed by RF Micro Devices, Inc. ("RFMD") for its use, nor for any infringement of patents, or other rights of third parties, resulting from its use. No license is granted by implication or otherwise under any patent or patent rights of RFMD. RFMD reserves the right to change component circuitry, recommended application circuitry and specifications at any time without prior notice.

Operation of this device beyond any one of these limits may cause permanent damage. For reliable continuous operation, the device voltage and current must not exceed the maximum operating values specified in the table on page one.

Bias Conditions should also satisfy the following expression:

$$I_D V_D < (T_J - T_L) / R_{TH, j-l} \text{ and } T_L = T_{LEAD}$$

## Typical Performance at Key Operating Frequencies

| Parameter                          | Unit | 100MHz | 500MHz | 850MHz | 1950MHz | 2400MHz | 3500MHz |
|------------------------------------|------|--------|--------|--------|---------|---------|---------|
| Small Signal Gain                  | dB   | 15.3   | 15.3   | 15.0   | 14.6    | 14.3    | 13.2    |
| Output Third Order Intercept Point | dBm  | 37.1   | 36.2   | 36.5   | 33.5    | 32.7    | 30.5    |
| Output Power at 1dB Compression    | dBm  | 19.0   | 19.1   | 19.0   | 19.0    | 18.3    | 16.3    |
| Input Return Loss                  | dB   | 47     | 33     | 29     | 21      | 17.5    | 13.3    |
| Output Return Loss                 | dB   | 22     | 22     | 21     | 15      | 13.3    | 12      |
| Reverse Isolation                  | dB   | 18     | 18     | 18.7   | 19      | 19      | 19      |
| Noise Figure                       | dB   | 4.1    | 4.3    | 4.2    | 4.8     | -       | -       |

Test Conditions:  $V_S = 8V$ ,  $I_D = 80mA$  Typ., OIP<sub>3</sub> Tone Spacing = 1MHz, P<sub>OUT</sub> per tone = 0dBm, R<sub>BIAS</sub> = 39Ω, T<sub>L</sub> = 25°C, Z<sub>S</sub> = Z<sub>L</sub> = 50Ω

Noise Figure vs Frequency

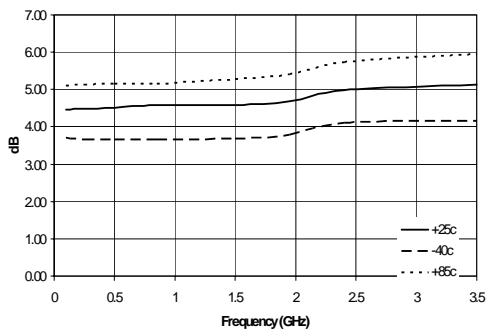

OIP3 vs Frequency

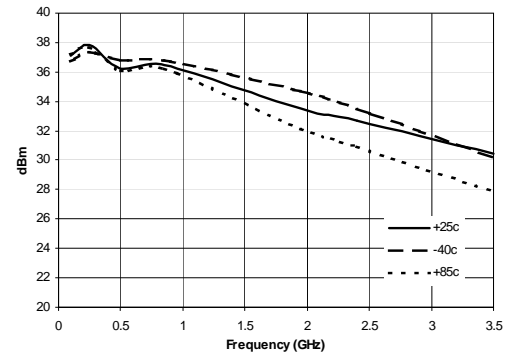

P1dB vs Frequency

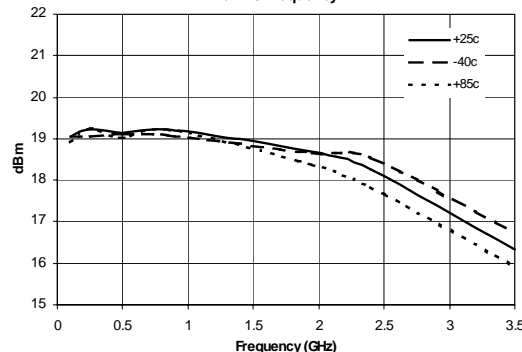

**$|S_{11}|$  vs. Frequency**

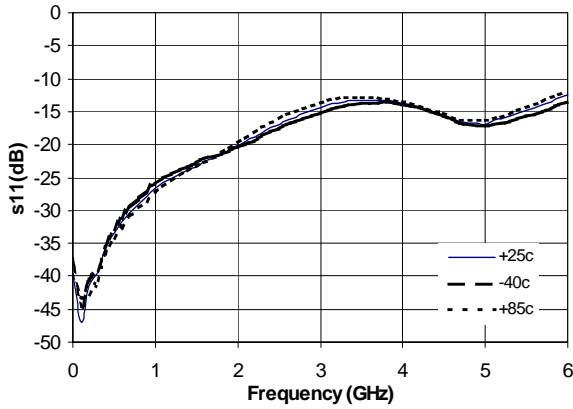

**$|S_{21}|$  vs. Frequency**

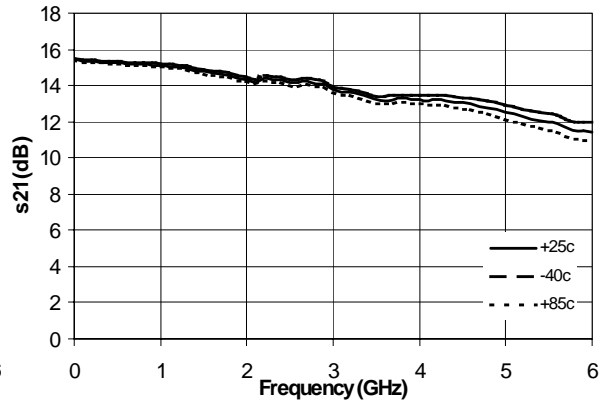

**$|S_{12}|$  vs. Frequency**

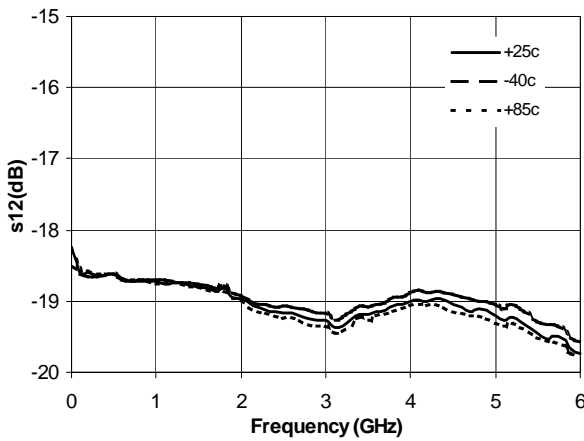

**$|S_{22}|$  vs. Frequency**

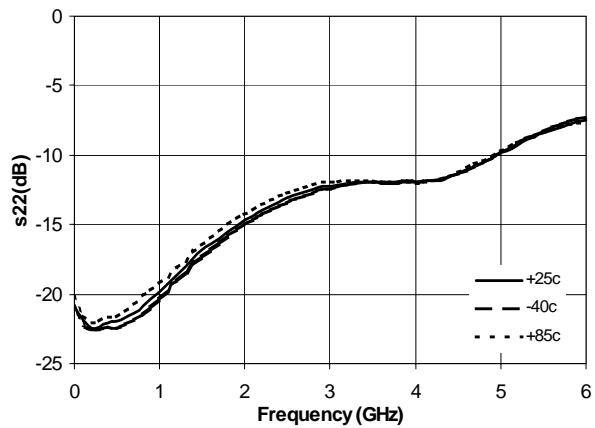

**IS-95 @ 850MHz  
Adj. Channel Pwr. Vs. Channel Output Pwr.**

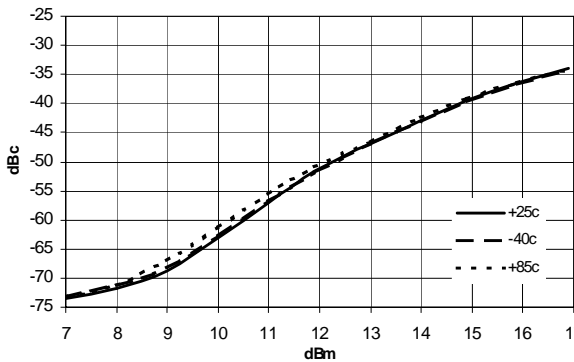

**IS-95 @ 1950MHz  
Adj. Channel Pwr. Vs. Channel Output Pwr.**

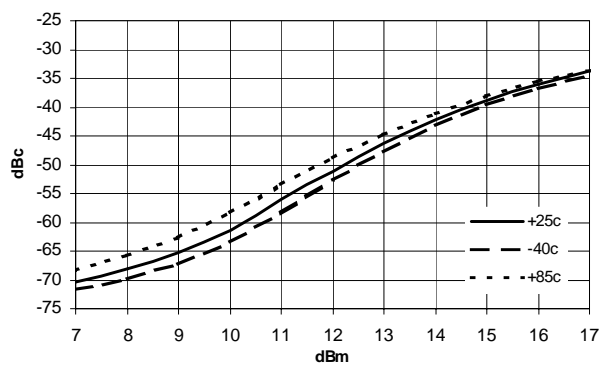

## Basic Application Circuit

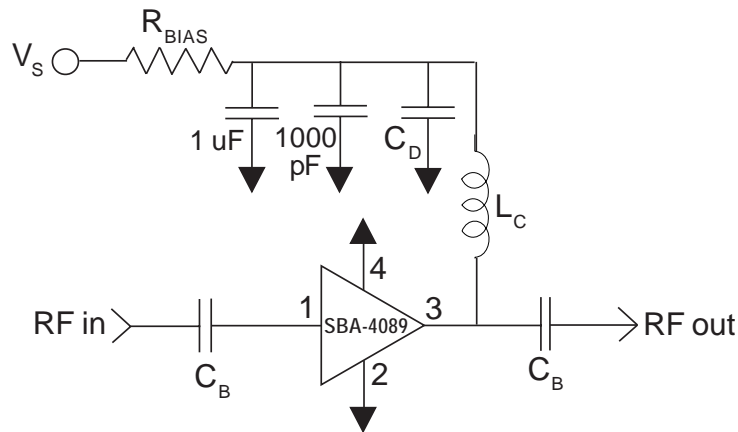

## Evaluation Board Layout

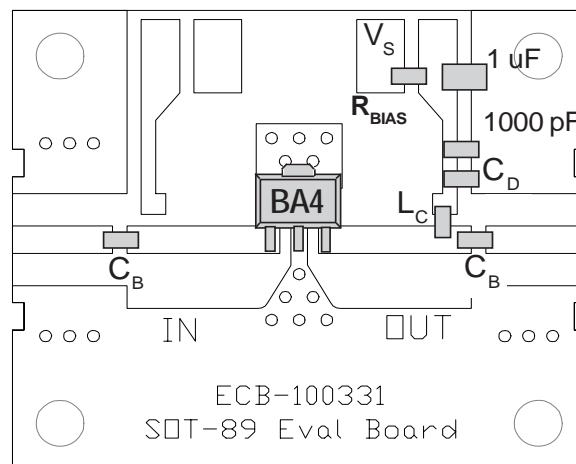

### Mounting Instructions:

1. Solder the copper pad on the backside of the device package to the ground plane.
2. Use a large ground pad area under device pins 2 and 4 with many plated through-holes as shown.
3. We recommend 1 or 2 ounce copper. Measurements for this data sheet were made on a 31mil thick FR-4 board with 1 ounce copper on both sides.

### Application Circuit Element Values

| Reference Designator | 500 MHz | 850 MHz | 1950 MHz | 2400 MHz | 3500 MHz |
|----------------------|---------|---------|----------|----------|----------|
| $C_B$                | 220 pF  | 100 pF  | 68 pF    | 56 pF    | 39 pF    |
| $C_D$                | 100 pF  | 68 pF   | 22 pF    | 22 pF    | 15 pF    |
| $L_C$                | 68 nH   | 33 nH   | 22 nH    | 18 nH    | 15 nH    |

### Recommended Bias Resistor Values for $I_D = 80 \text{ mA}$ , $R_{BIAS} = (V_S - V_D) / I_D$

|                          |             |             |             |             |
|--------------------------|-------------|-------------|-------------|-------------|
| Supply Voltage ( $V_S$ ) | 7.5V        | 8V          | 10V         | 12V         |
| $R_{BIAS}$               | 33 $\Omega$ | 39 $\Omega$ | 68 $\Omega$ | 91 $\Omega$ |

Note:  $R_{BIAS}$  provides DC bias stability over temperature.

| Pin  | Function    | Description   |
|------|-------------|---|
| 1    | RF IN       | RF input pin. This pin requires the use of an external DC-blocking capacitor chosen for the frequency of operation.             |
| 2, 4 | GND         | Connection to ground. Use via holes for best performance to reduce lead inductance as close to ground leads as possible.        |
| 3    | RF OUT/BIAS | RF output and bias pin. DC voltage is present on this pin, therefore a DC-blocking capacitor is necessary for proper operation. |

**PCB Pad Layout**

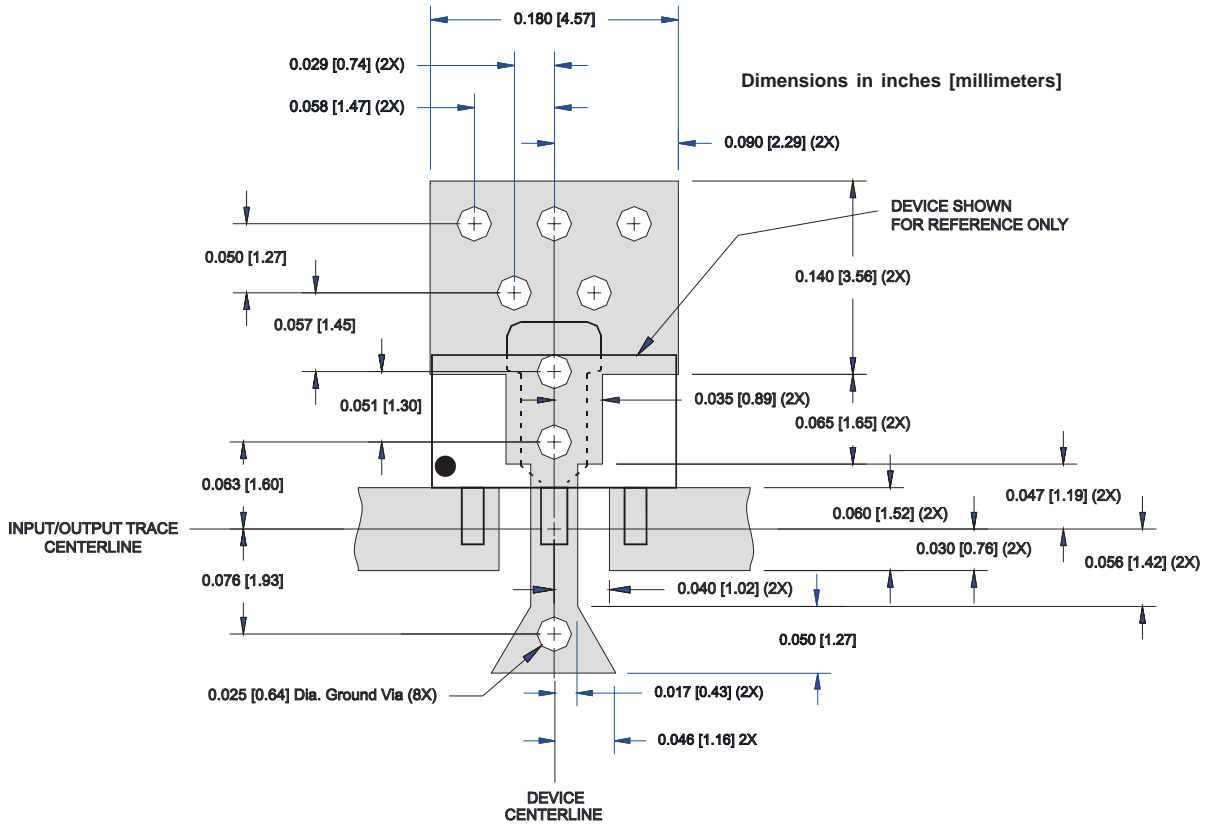

## Package Drawing

Dimensions in inches (millimeters)

Refer to drawing posted at [www.rfmd.com](http://www.rfmd.com) for tolerances.

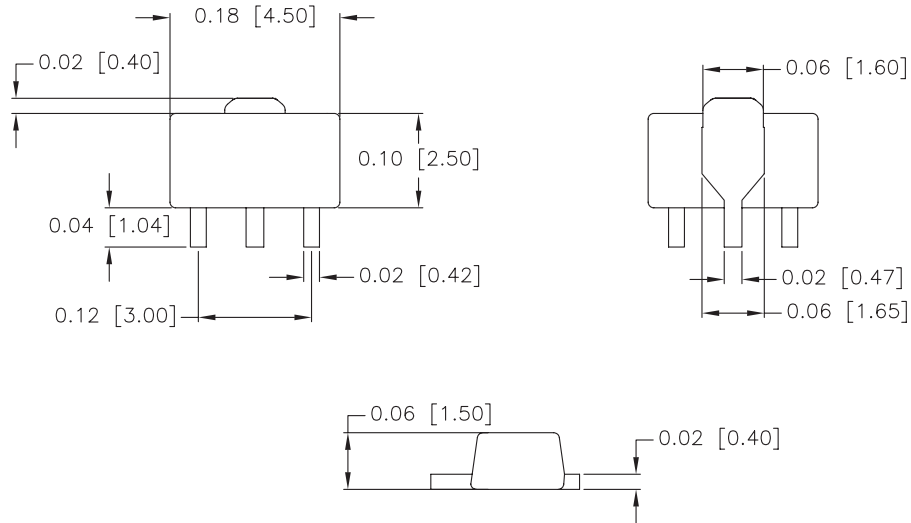

## Part Identification

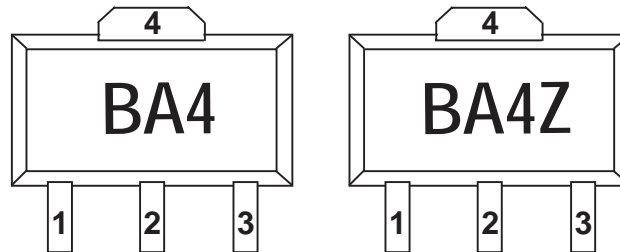

The part will be marked with a “BA4” or “BA4Z” designator on the top surface of the package. Alternate marking is “SBA4089” or “SBA4089Z” on line 1 with Trace Code on Line 2.

## Ordering Information

| Part Number | Reel Size | Devices/Reel |
|-------------|-----------|--------------|
| SBA-4089    | 7"        | 1000         |
| SBA-4089Z   | 7"        | 1000         |